

GENESIS

E-335W • E-435W
E-335LW • E-435LW



MONTAGEHANDLEIDING

MONTAGEANLEITUNG

NOTICE DE MONTAGE

GUIDA ALL'ASSEMBLAGGIO



BILT®

Download on the
App Store

GET IT ON
Google Play

8654809

100124
NL / DE / FR / IT



NL

- △ Knip alle vier hoeken van de doos in en vouw de zijanten naar beneden.
- △ Monteer de barbecue op een vlakke, horizontale en zachte ondergrond.
- △ Verwijder de beschermende folie van de roestvrijstalen onderdelen voordat je de barbecue monteert.
- △ Gebruik geen elektrisch gereedschap voor de montage.
- △ Er zijn twee personen nodig voor de montage.
- △ Er zijn mogelijk visuele verschillen te zien tussen de afbeeldingen en het model dat je hebt aangeschaft.
- △ Zorg altijd dat het deksel gesloten is wanneer je je barbecue monteert of verplaatst.

DE

- △ Alle vier Ecken des Kartons aufschneiden und Seitenwände herunterklappen.
- △ Den Grill auf einem flachen, ebenen und weichen Untergrund montieren.
- △ Vor der Montage die Schutzfolien von den Edelstahlflächen entfernen.
- △ Für die Montage keine Elektrowerkzeuge verwenden.
- △ Die Montage muss von zwei Personen durchgeführt werden.
- △ Das erworbene Modell kann geringfügig von der Darstellung abweichen.
- △ Den Deckel beim Zusammenbauen oder Bewegen des Grills stets geschlossen halten.

FR

- △ Découpez les quatre coins du carton et repliez les rabats.
- △ Procédez au montage du barbecue sur une surface plane, horizontale et non rugueuse.
- △ Retirez le film protecteur des éléments en acier inoxydable avant l'installation.
- △ N'utilisez pas d'outils électriques pour le montage.
- △ Le montage requiert deux personnes.
- △ Les illustrations et le modèle acheté peuvent présenter des différences visuelles.
- △ Gardez toujours le couvercle fermé lorsque vous assemblez ou déplacez votre barbecue.

IT

- △ Tagliare i quattro gli angoli del cartone e piegare i lati verso il basso.
- △ Assemblare il barbecue su una superficie piana, livellata e morbida.
- △ Rimuovere la pellicola protettiva dalle parti in acciaio inox prima dell'installazione.
- △ Non utilizzare utensili elettrici per l'assemblaggio.
- △ Per l'assemblaggio sono necessarie due persone.
- △ Il modello acquistato potrebbe differire visivamente da quello illustrato.
- △ Tenere sempre chiuso il coperchio quando si assembla o si sposta il barbecue.

**BENODIGD GEREEDSCHAP:
ERFORDERLICHE WERKZEUGE:
OUTILS NÉCESSAIRES :
ATTREZZI NECESSARI:**

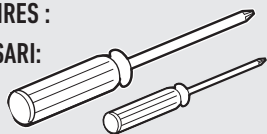

**INBEGREPEN GEREEDSCHAP:
ENTHALTENE WERKZEUGE:
OUTILS INCLUS :
ATTREZZI INCLUSI:**



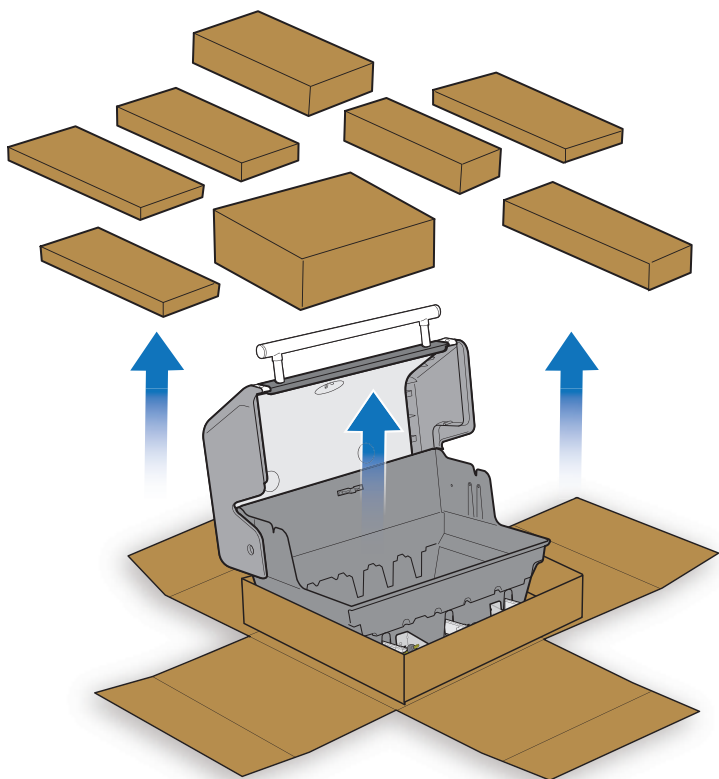
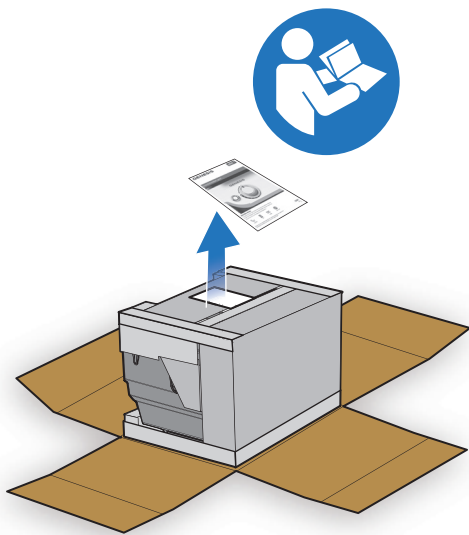
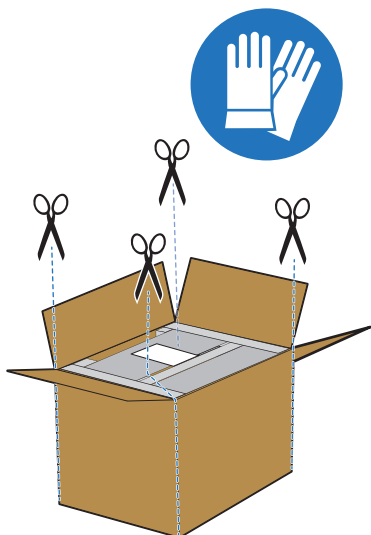





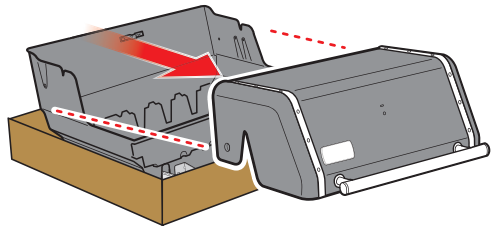
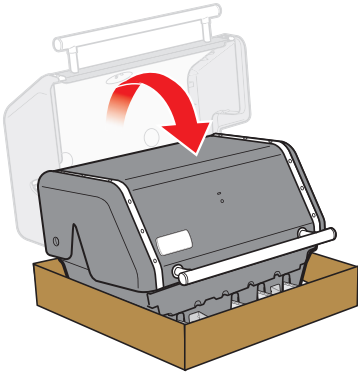
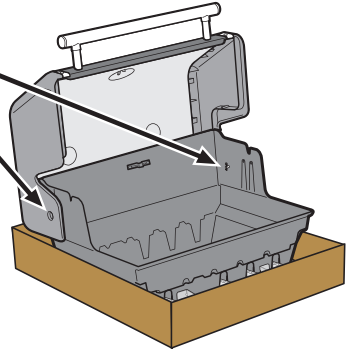
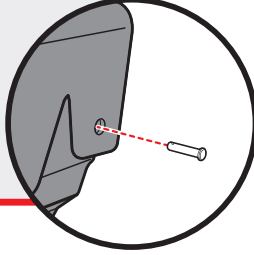
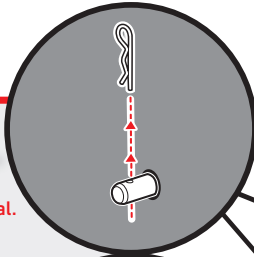

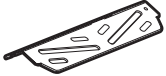





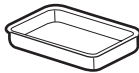
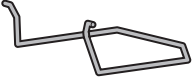

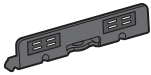

- △ Bewaar montagemateriaal.
- △ Beschläge aufbewahren.
- △ Conservez les vis.
- △ Conservare la minuteria.

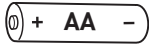

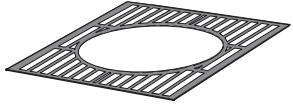
335	435	
3	4	
2	2	
2	2	
1	2	
2	2	
1	1	
1	1	
1	1	
1	1	
1	1	
1	1	
1	1	

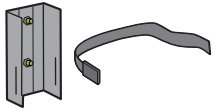
335	435	
1	1	
2	2	
5	7	
1	2	
1	1	
1	1	
2	2	
1	1	

335

435

1

1

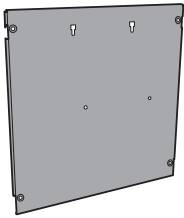

1

1

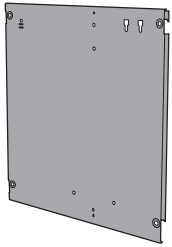

1

1

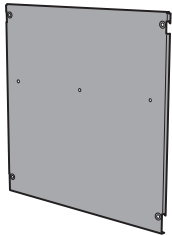

1

1



1

1



1

1

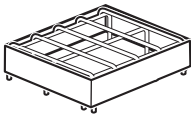

335

435

1

1

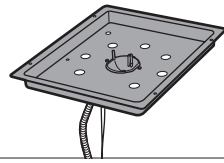

1

1



1

1

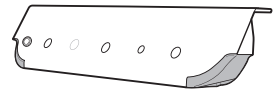

1

1

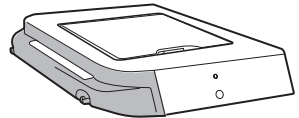

1

1

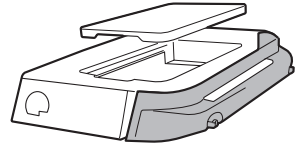

1

1

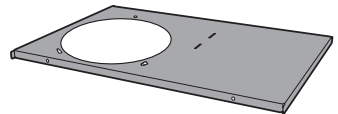

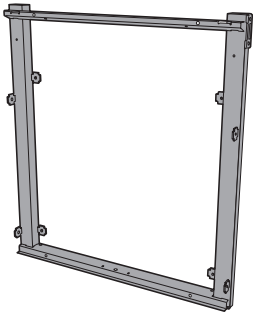
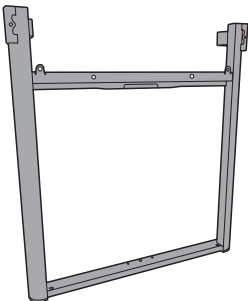
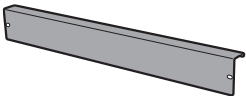
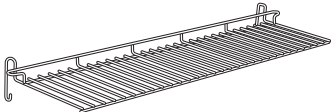
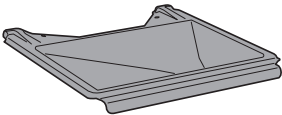
335	435	
1	1	
1	1	
1	1	
1	1	
1	1	

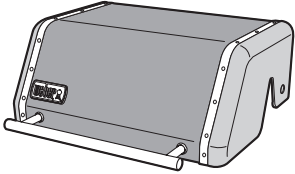
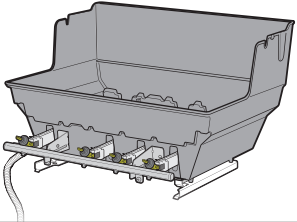
335	435	
1	1	
1	1	

E-335LW **E-435LW**

Alleen voor geselecteerde modellen.
Nur für ausgewählte Modelle.
Certains modèles uniquement.
Solo per modelli selezionati.

3	3	
---	---	--

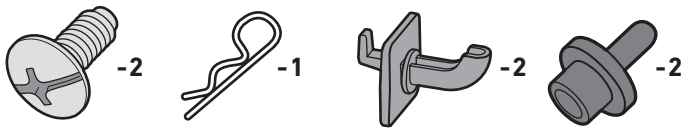
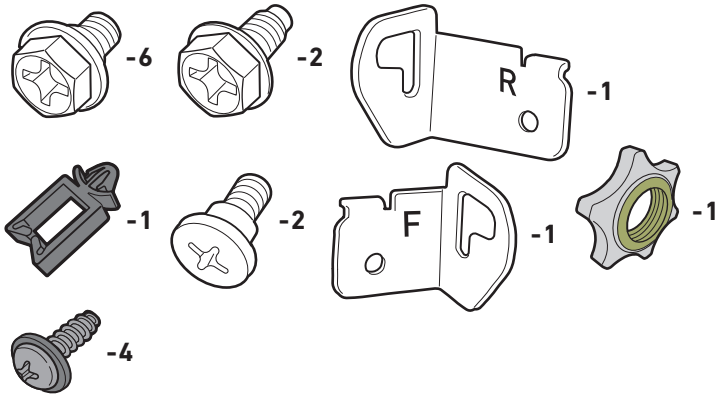
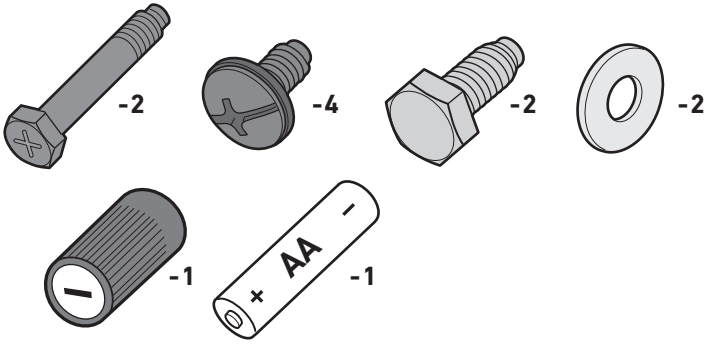
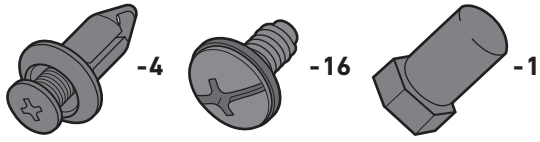

1

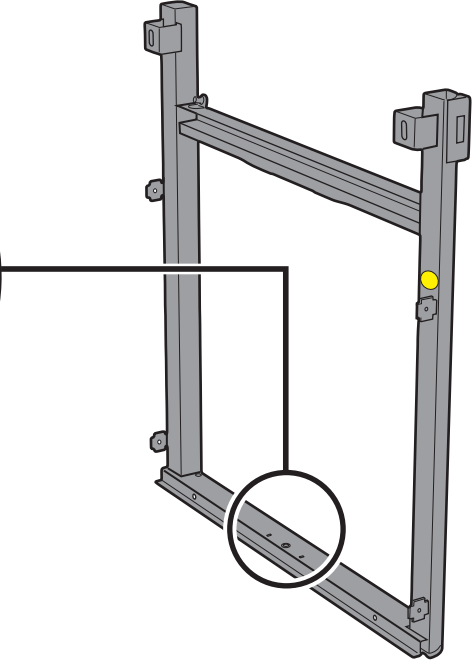
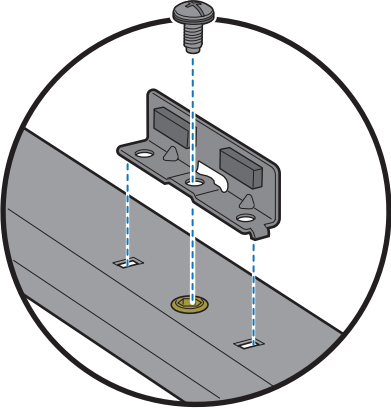
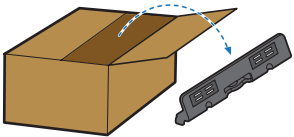
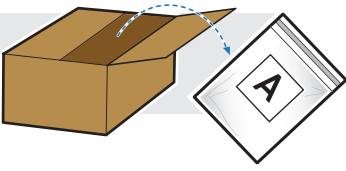

2

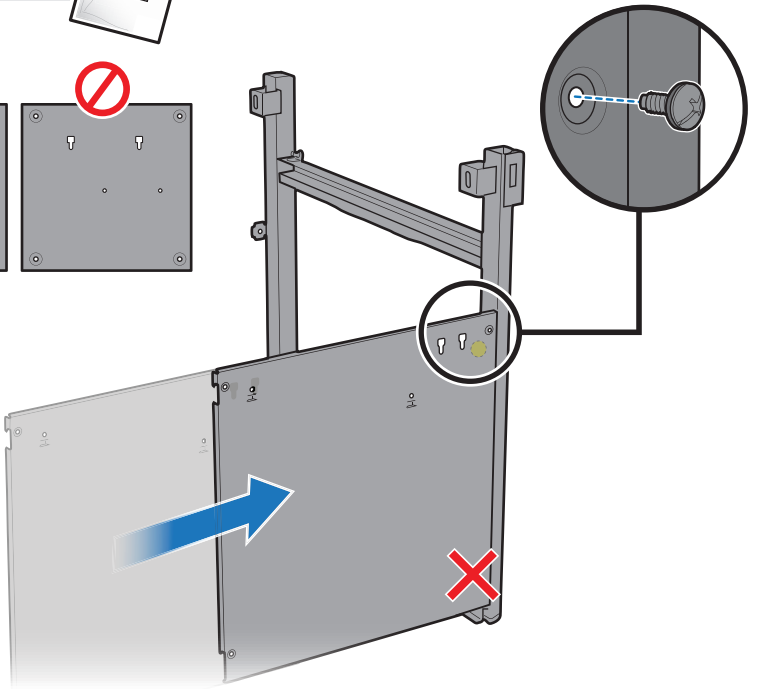
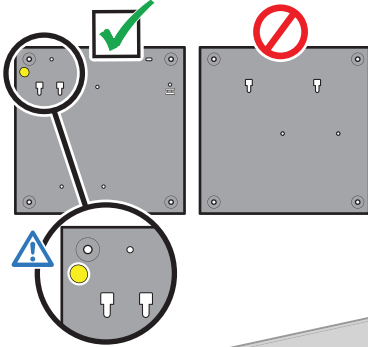

3

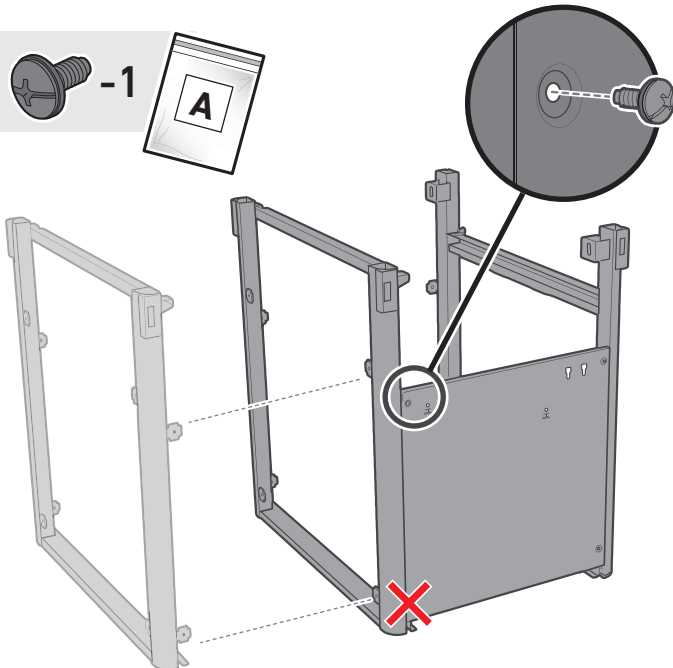

4

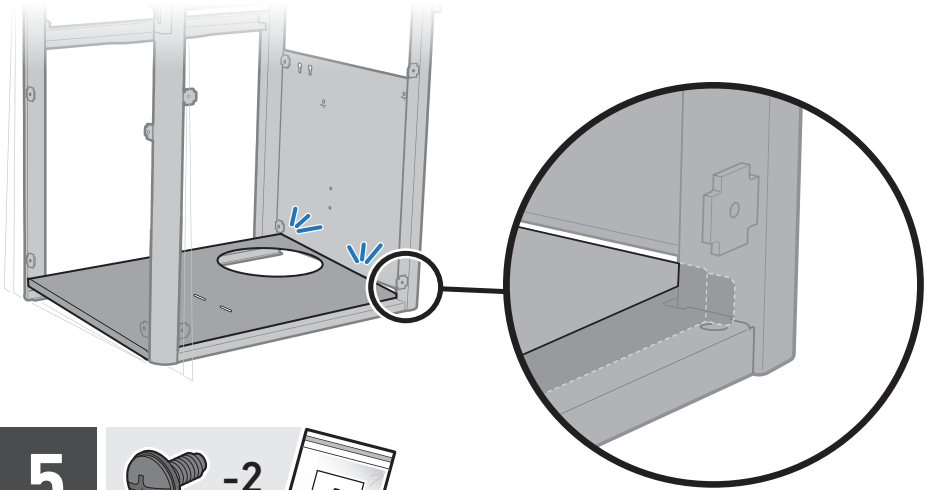
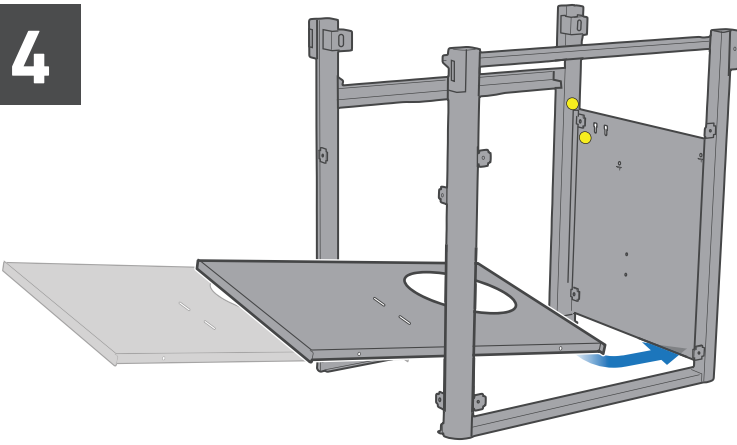

5



-2

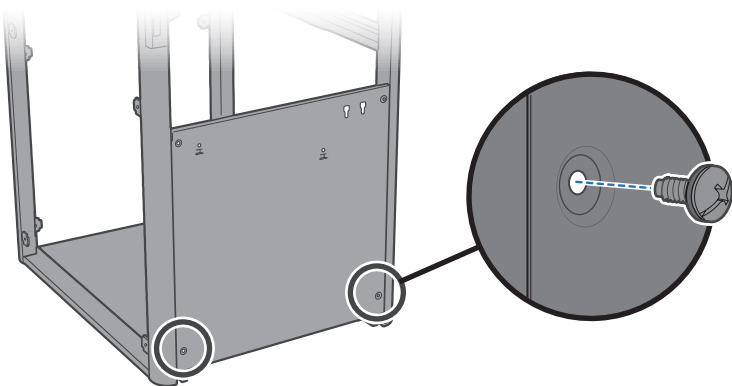

6



-4

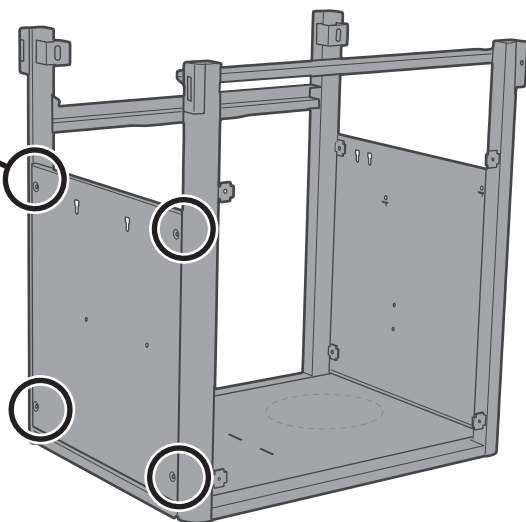
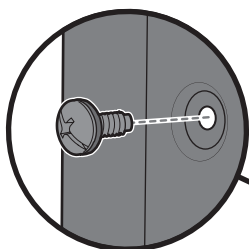
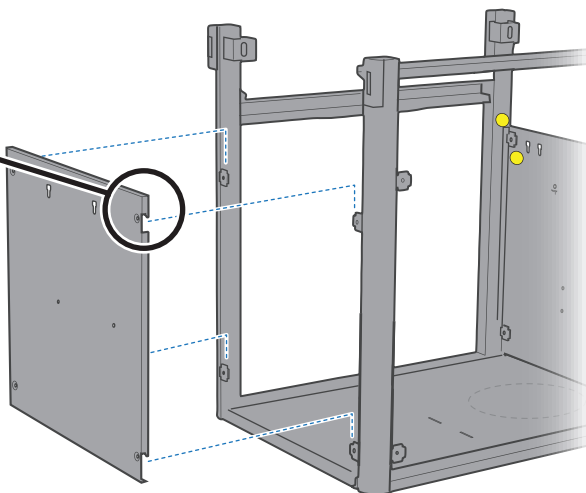
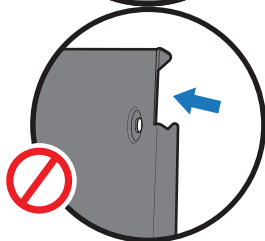
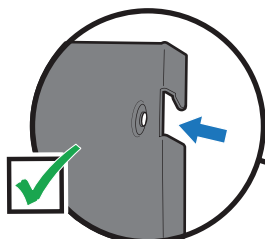
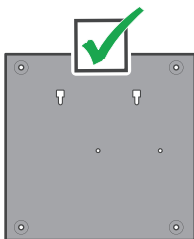

7



-1



-1

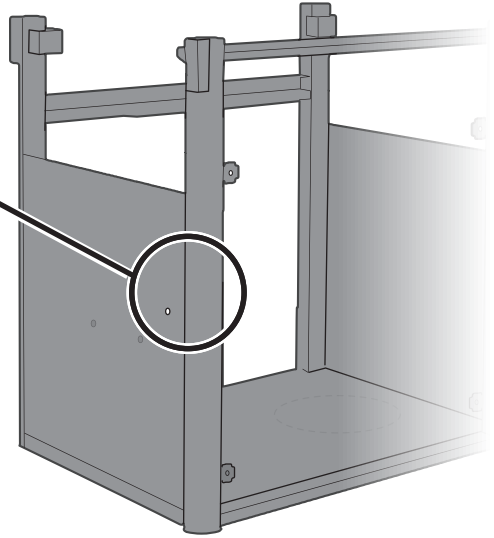
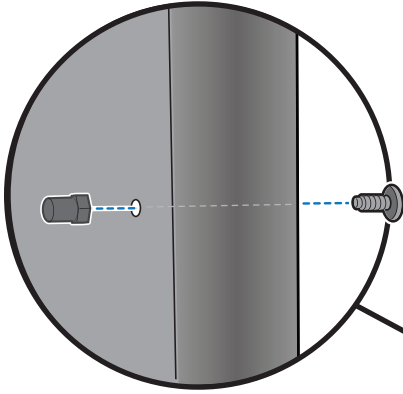

8



-4

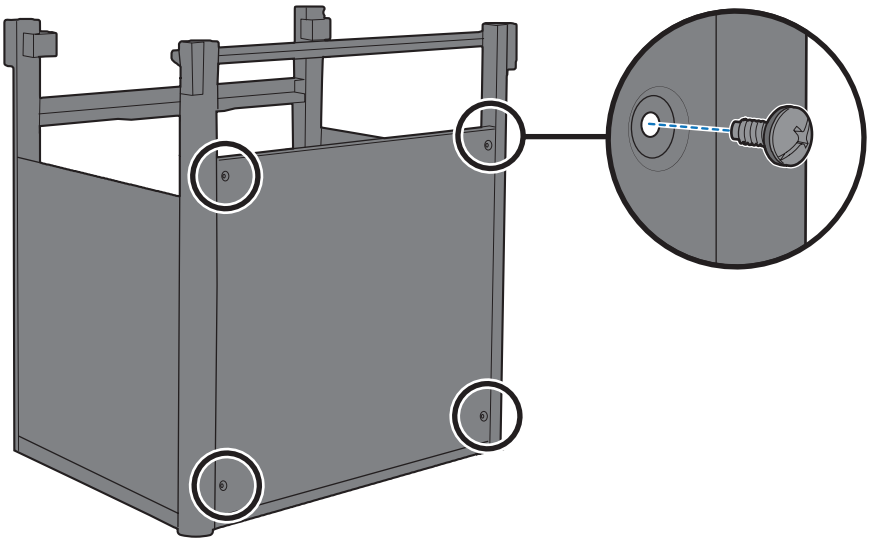
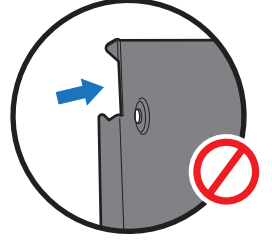
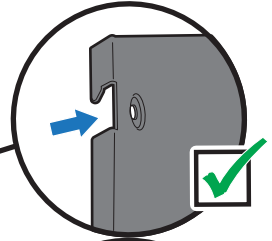
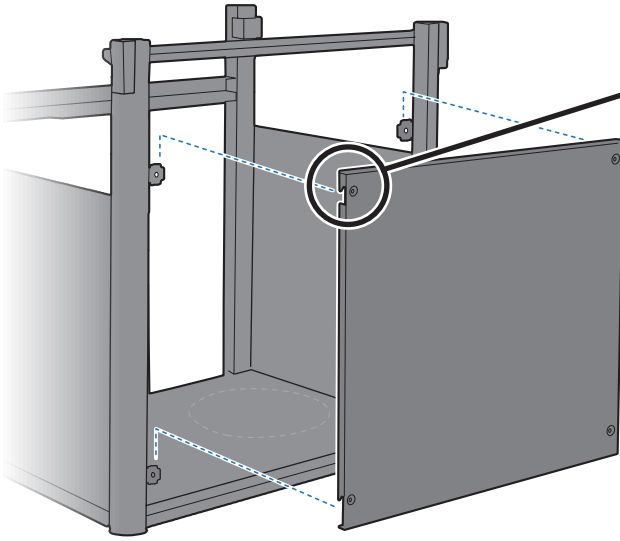

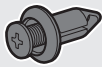
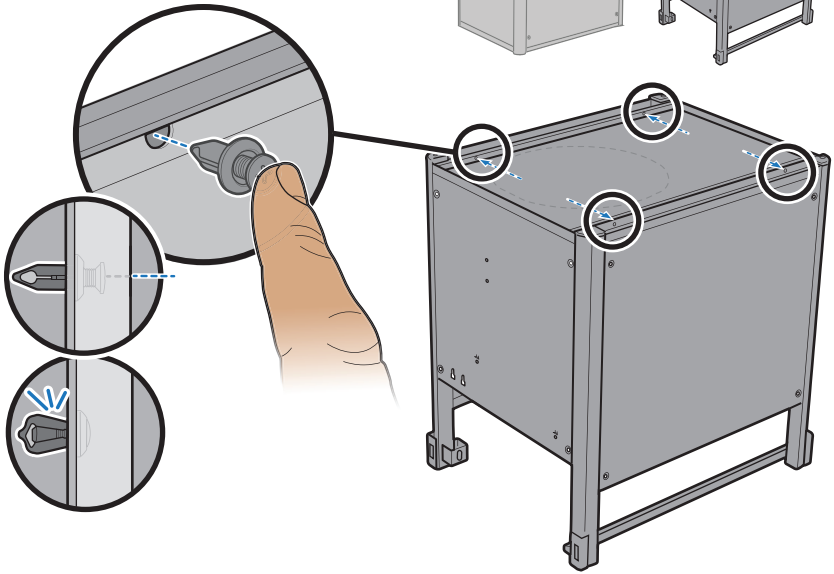
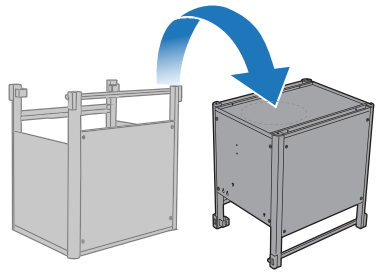
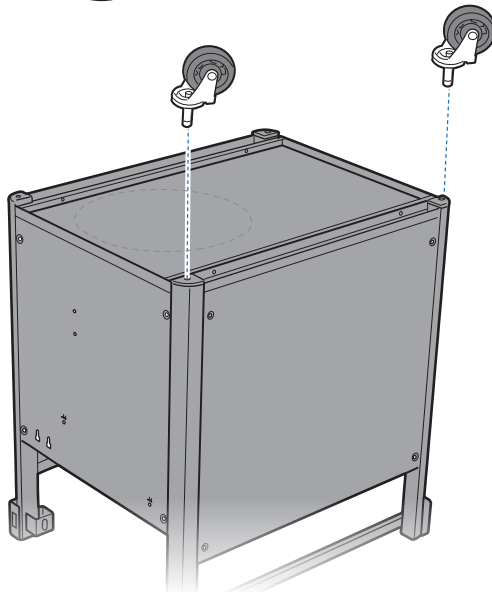
9**-4****10****-2**

11  -2

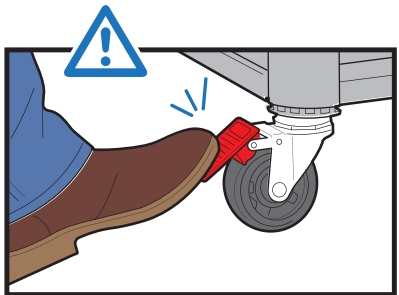
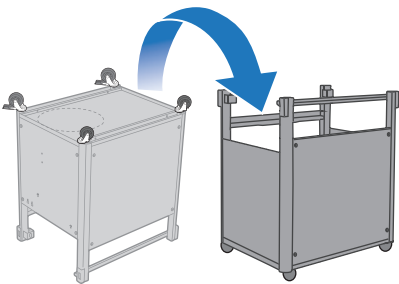
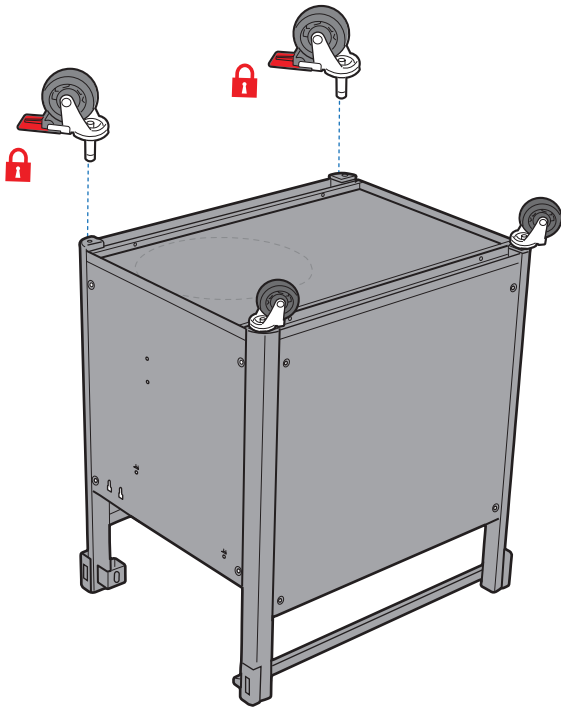

12

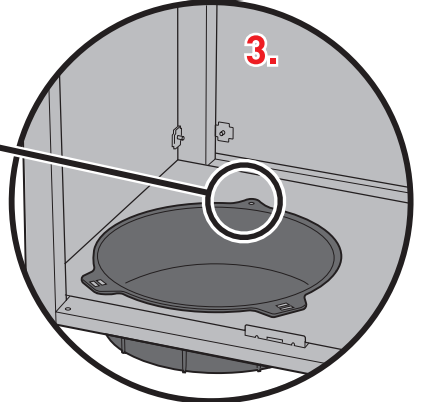
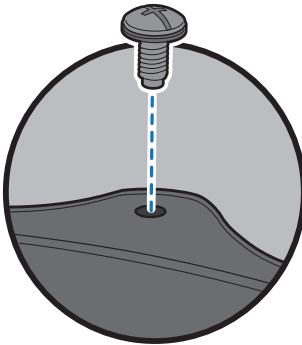
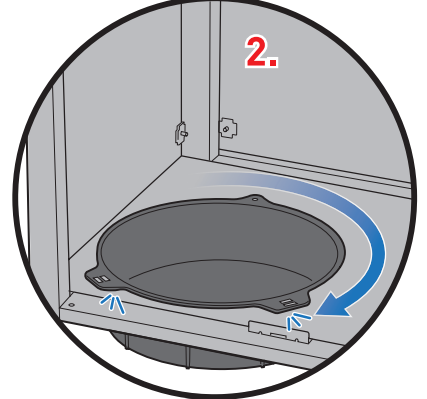
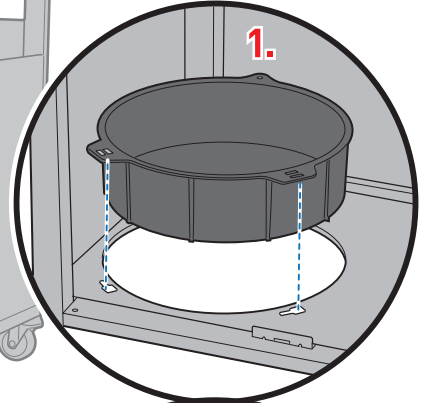
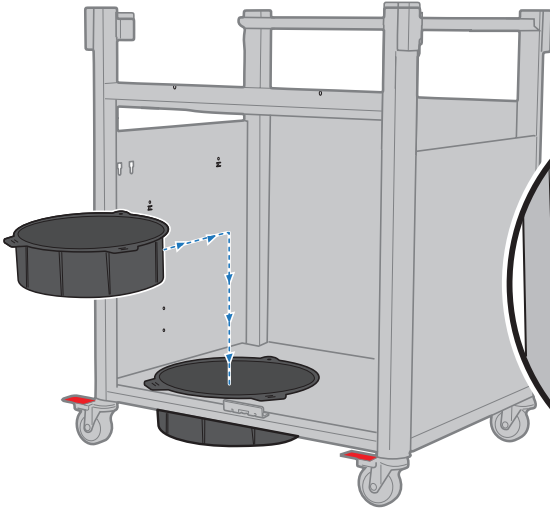

13



-2

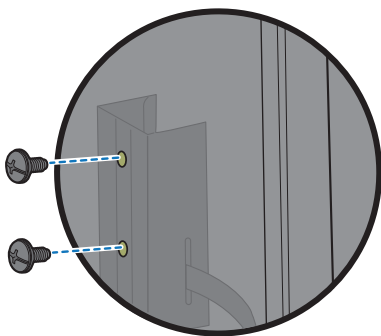
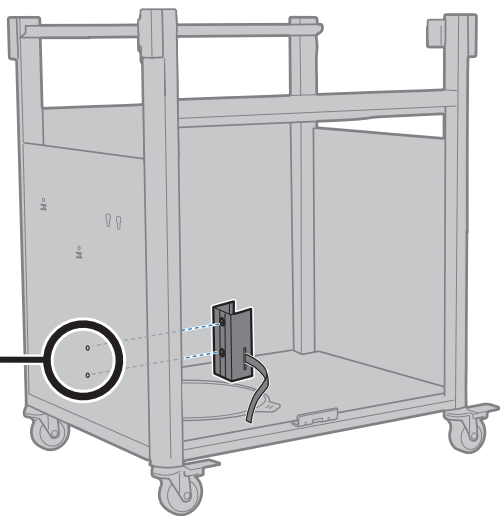
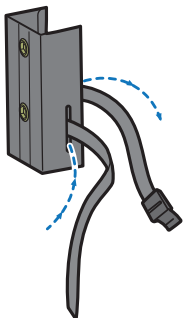

14

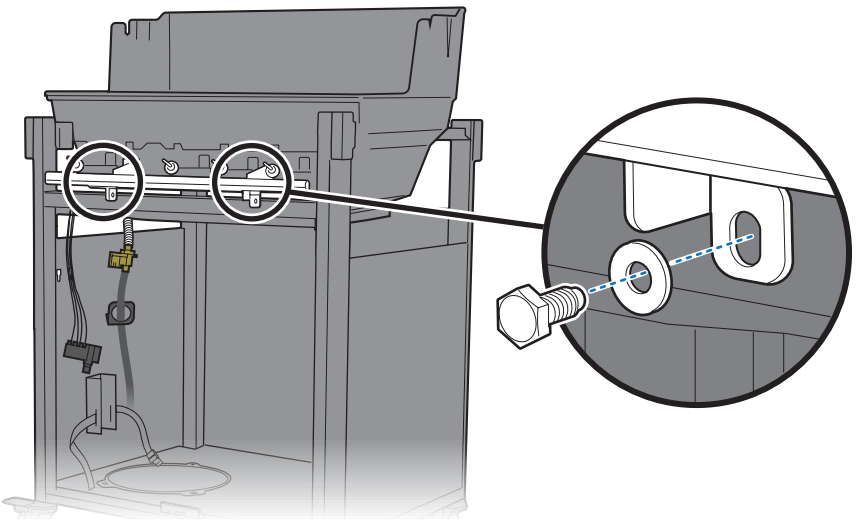
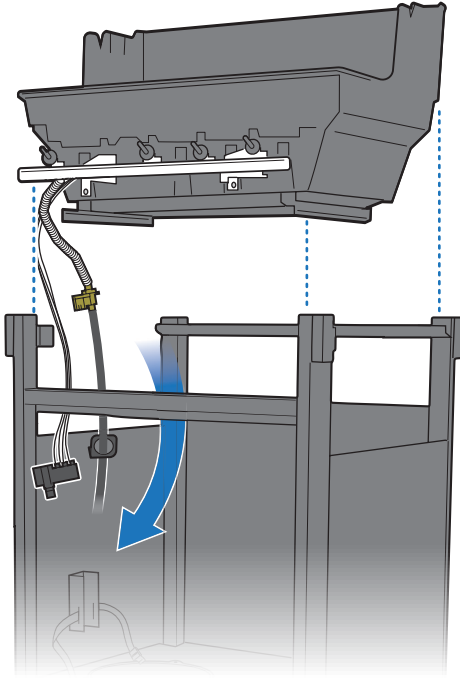
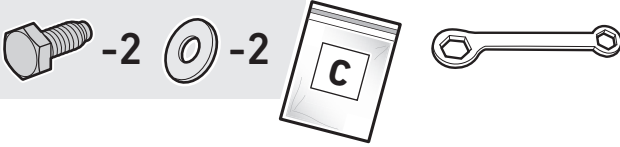

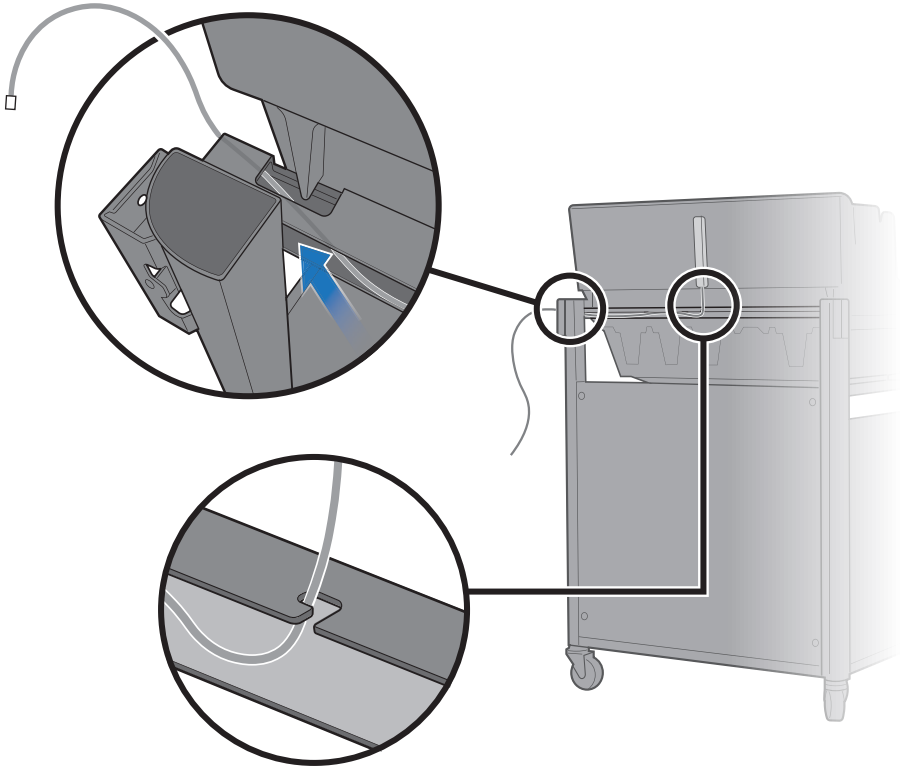

16

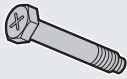

-2

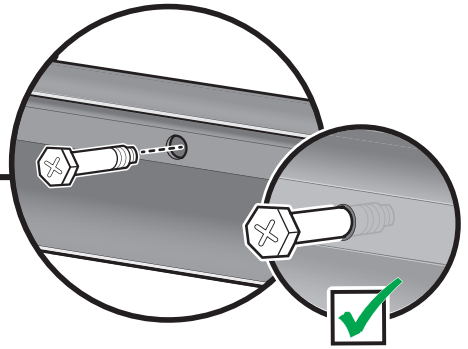
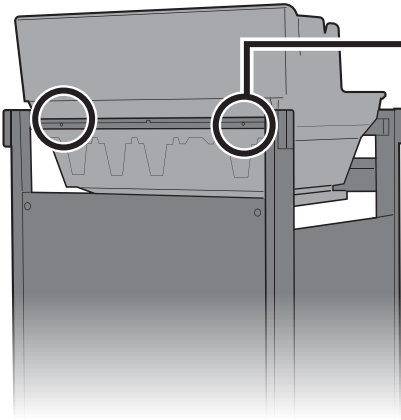

17



-2

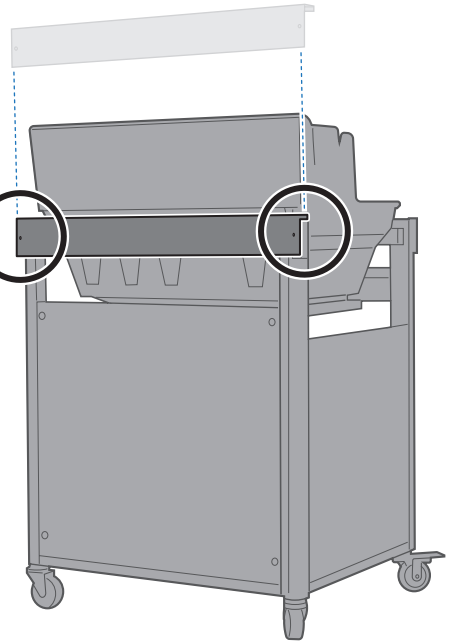
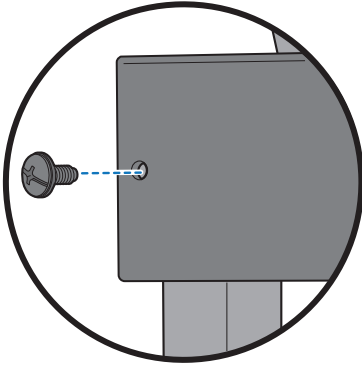

18



-1

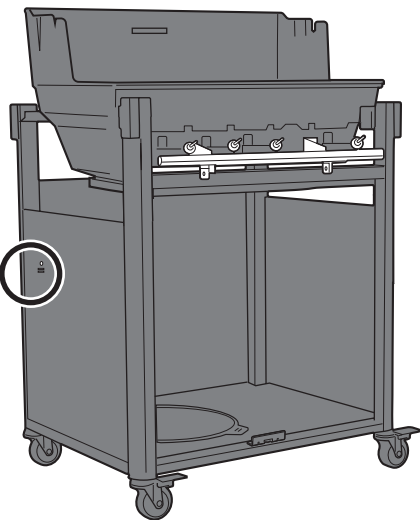
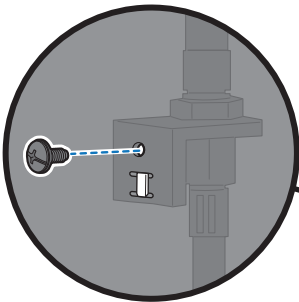
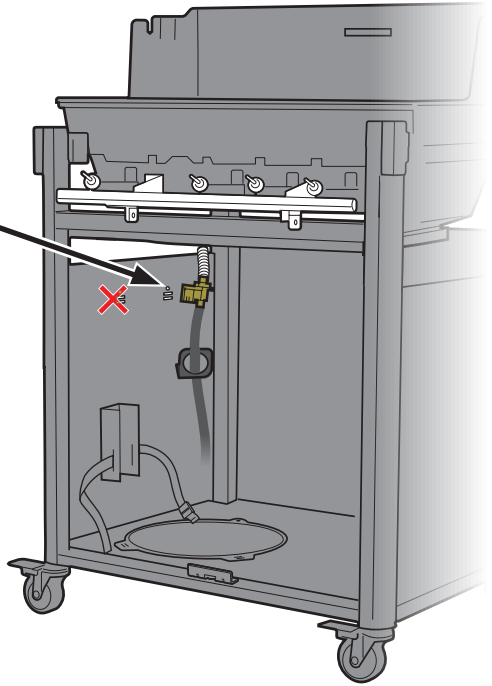
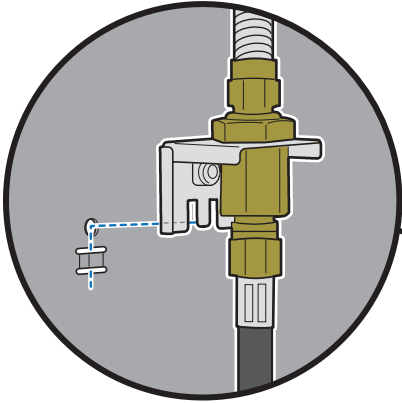

19



-1

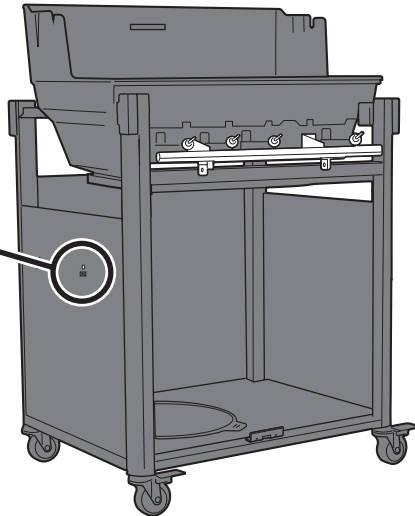
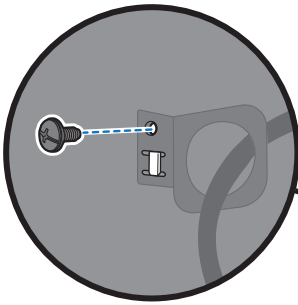
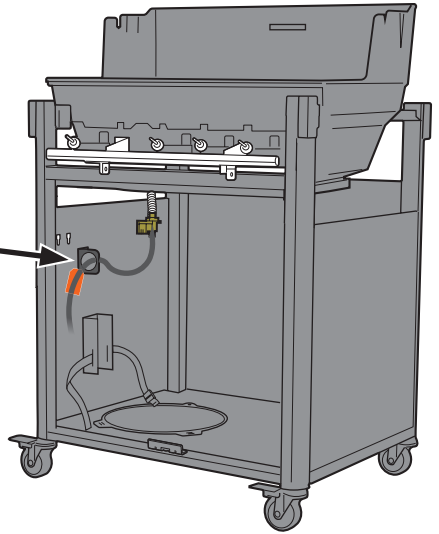
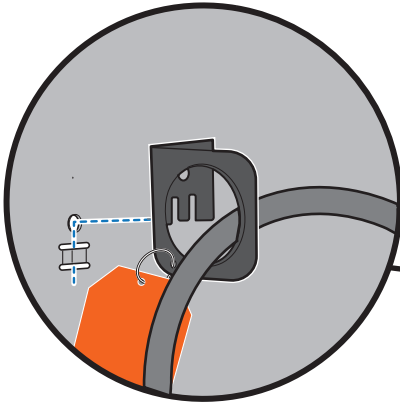

20

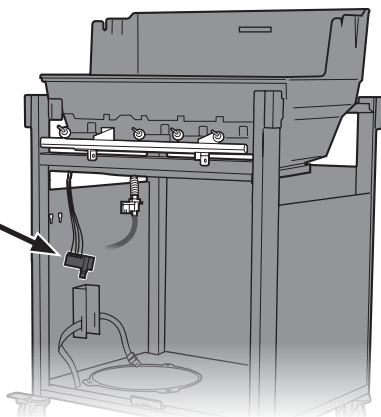
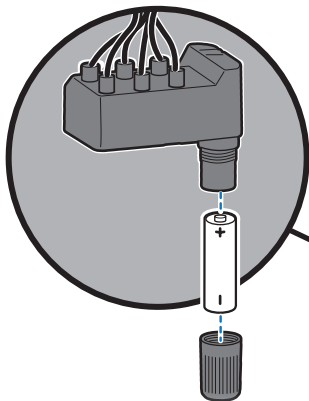
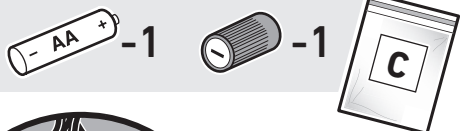

21

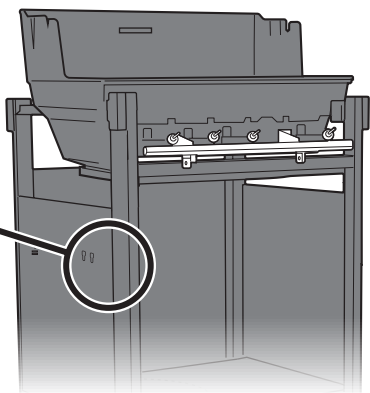
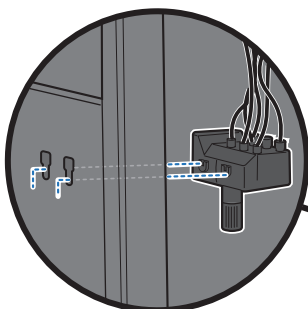

22

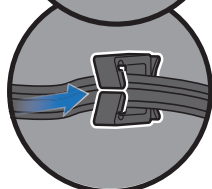
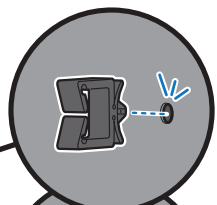
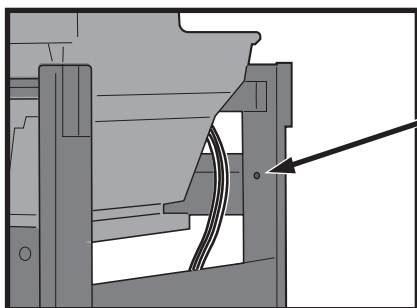

23



-2

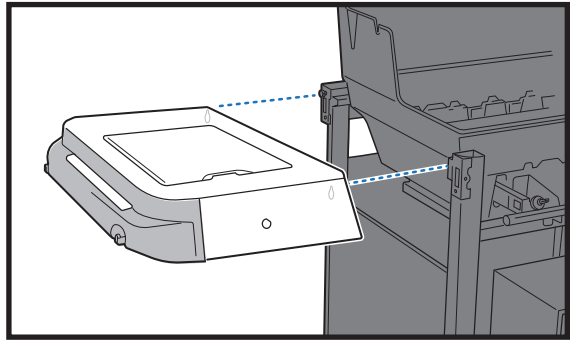
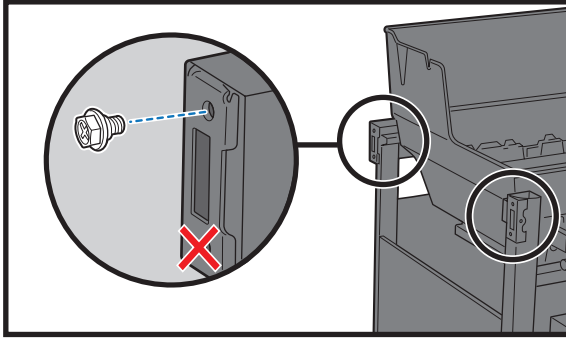
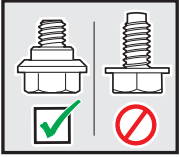

24



-2

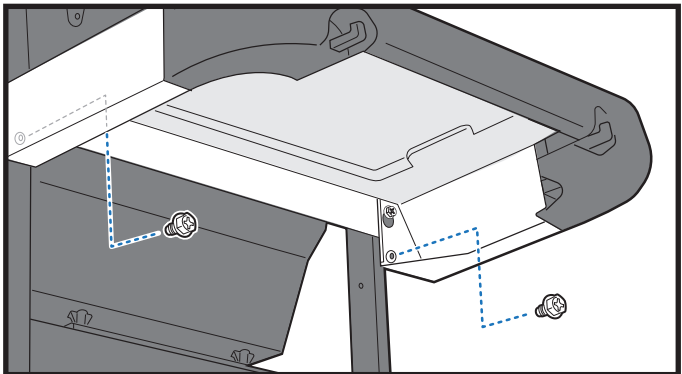
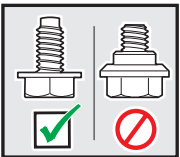

25

-4

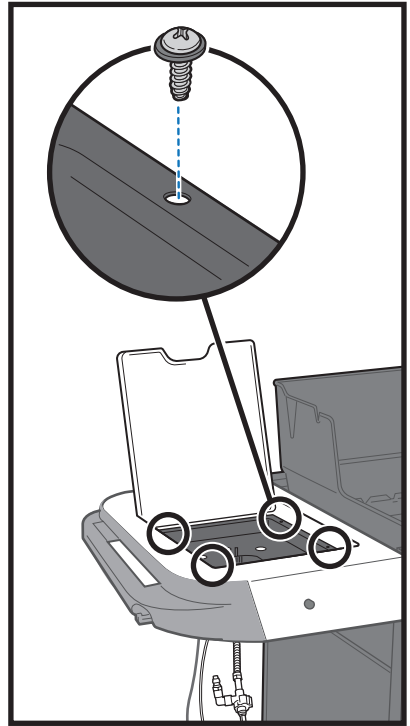
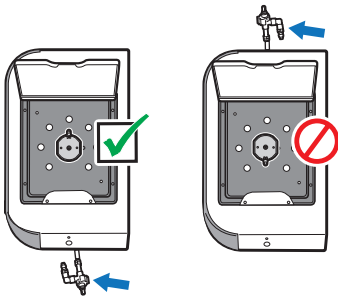
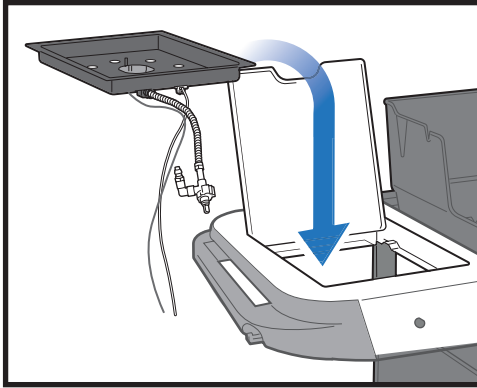

26

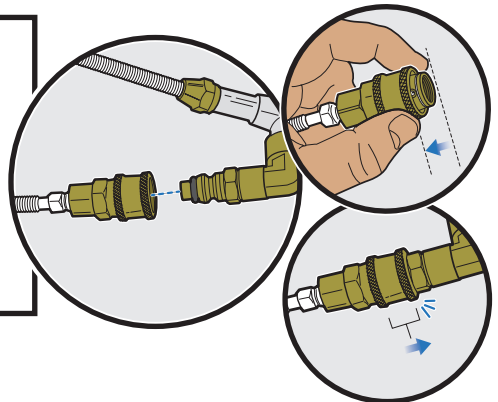
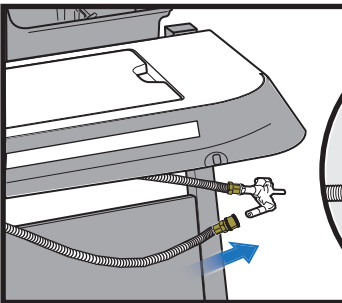

27

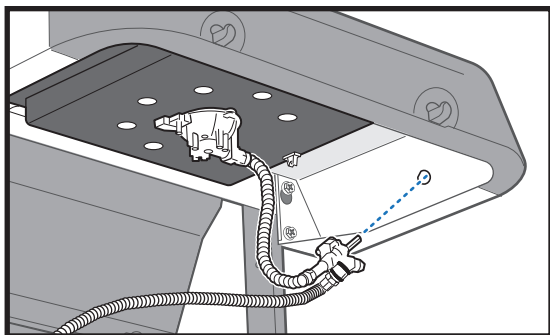

28

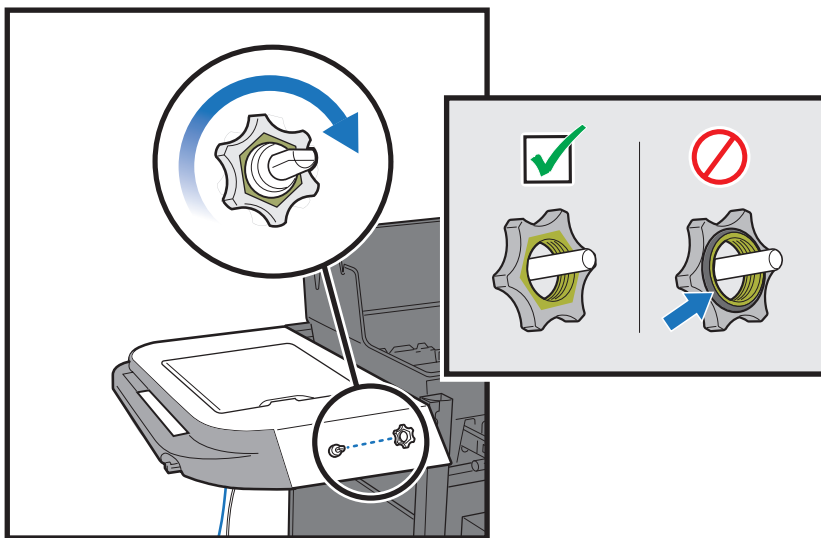

29

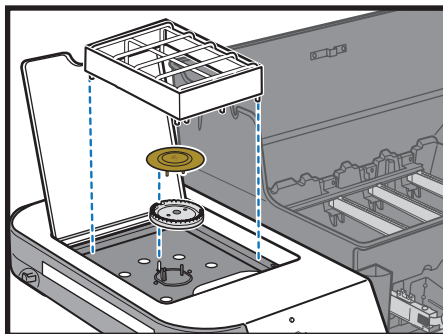

△ ALLEEN 335 MODELLEN:

△ MODÈLES 335 UNIQUEMENT:

△ NUR BEI 335-MODELLEN:

△ Solo modelli 335:

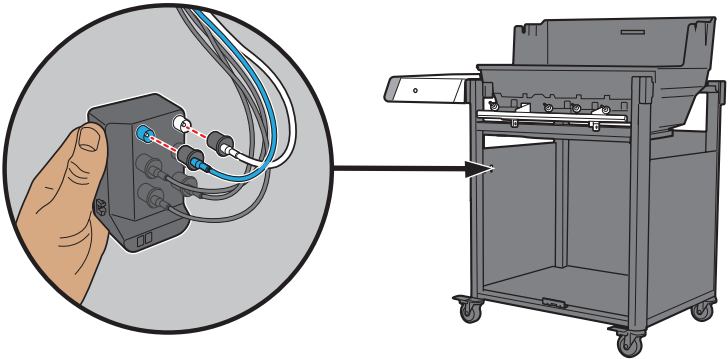
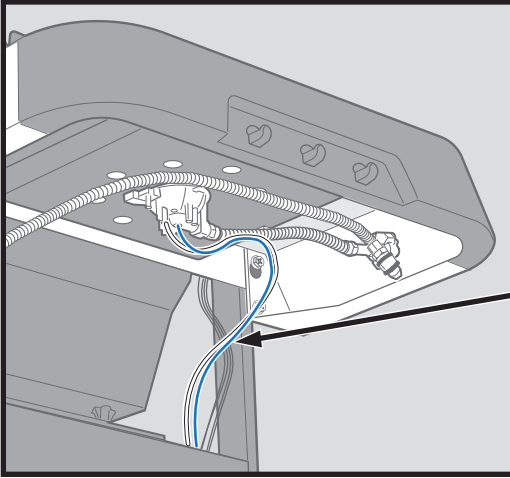

- ⚠ **ALLEEN 435 MODELLEN:**
- ⚠ **NUR BEI 435-MODELLEN:**
- ⚠ **MODÈLES 435 UNIQUEMENT:**
- ⚠ **Solo modelli 435:**

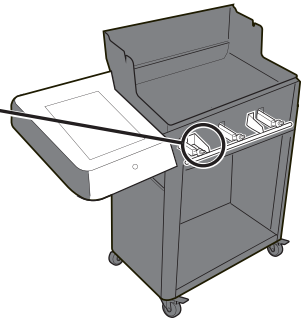
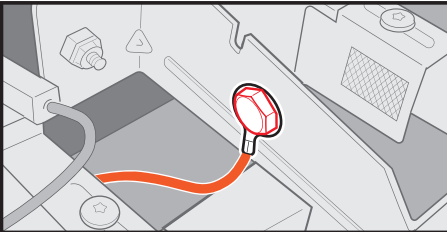
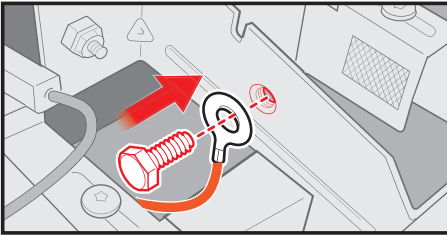
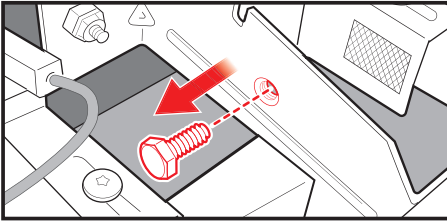
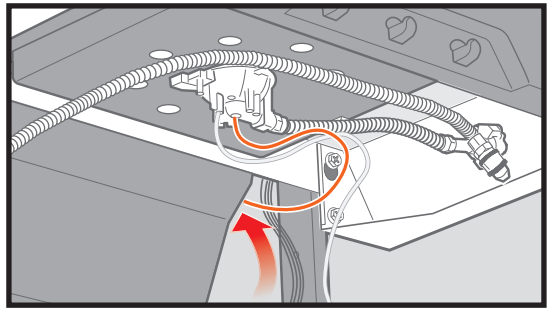

- ⚠ **ALLEEN 435 MODELLEN:** Bevestig de verbindingring met een schroef stevig aan het verdeelstuk.
- ⚠ **NUR BEI 435-MODELLEN:** Der Ringanschluss muss mithilfe einer Schraube fest mit dem Verteiler verbunden werden.
- ⚠ **MODÈLES 435 UNIQUEMENT:** Le connecteur en anneau doit être vissé fermement sur le collecteur.
- ⚠ **SOLO MODELLI 435:** Il connettore ad anello deve essere fissato saldamente al collettore con la vite.

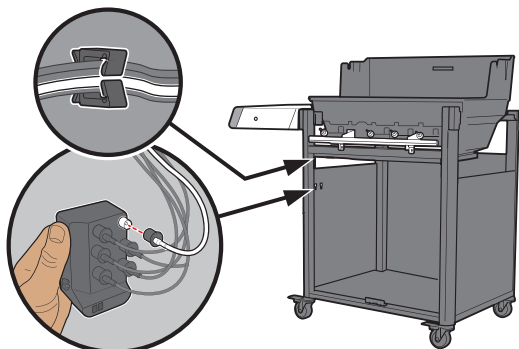

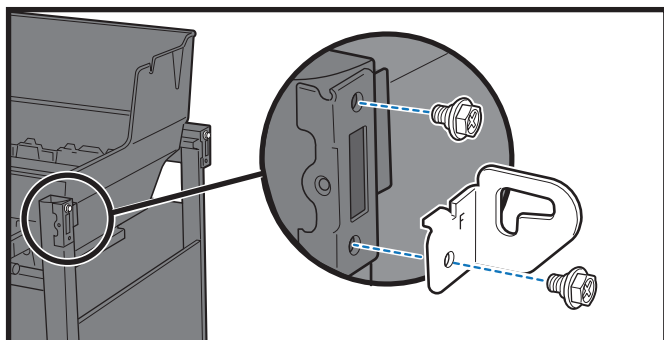
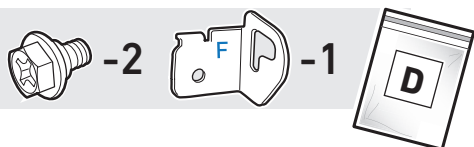
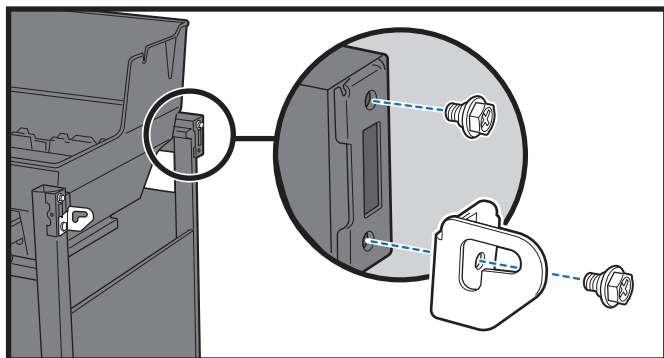
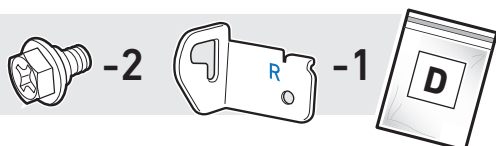
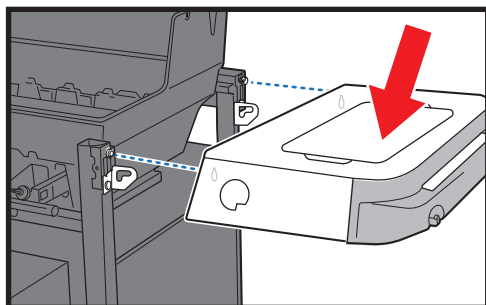
32**33****34**

Raadpleeg de gebruikershandleiding voor meer kenmerken en gebruik.

Hinweise über Funktionen und Gebrauch findest du im Benutzerhandbuch.

Référez-vous au mode d'emploi pour connaître les caractéristiques et l'utilisation.

Per le caratteristiche e l'uso, consultare la Guida utente.

35



-2

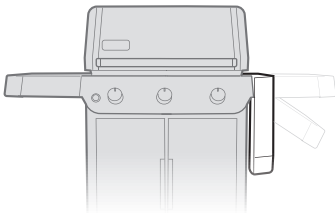
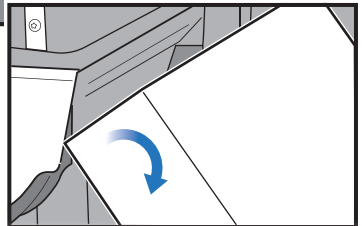
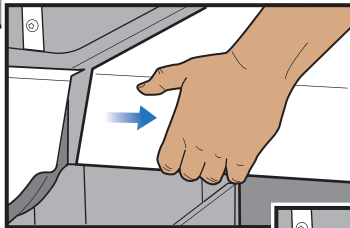
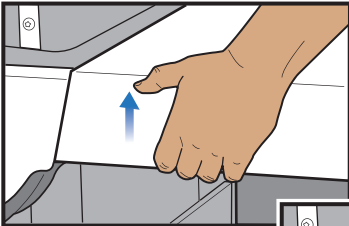
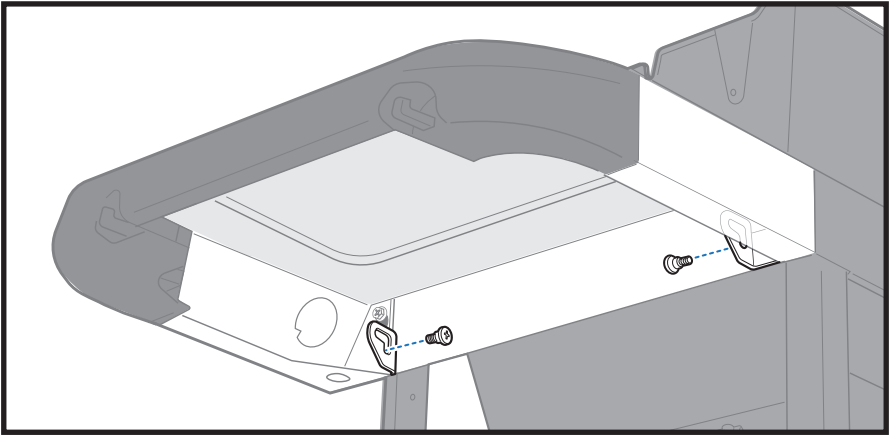

36

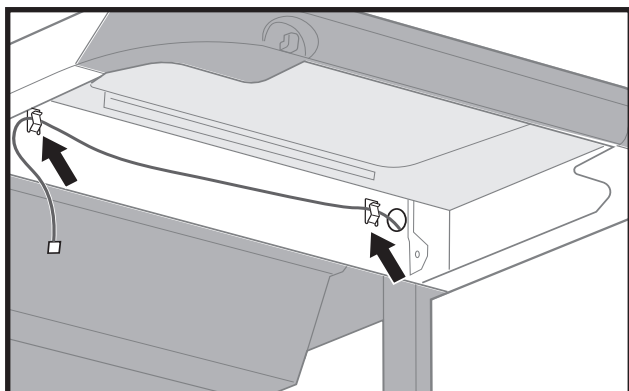
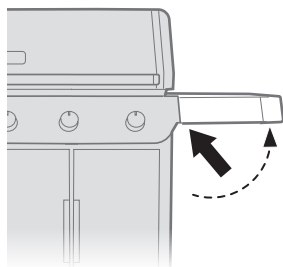
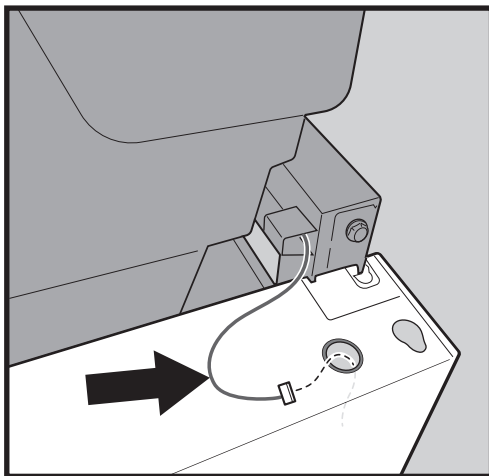
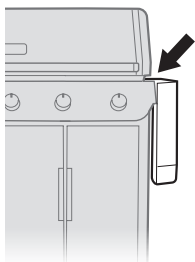

37 + AAA - 2

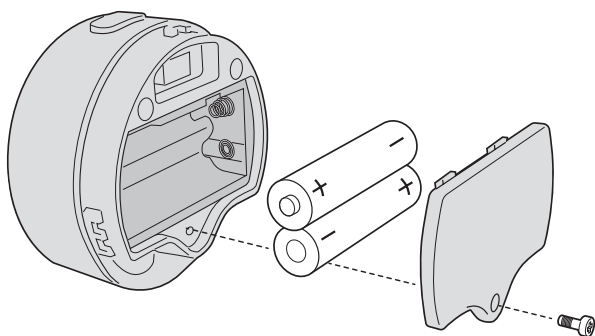

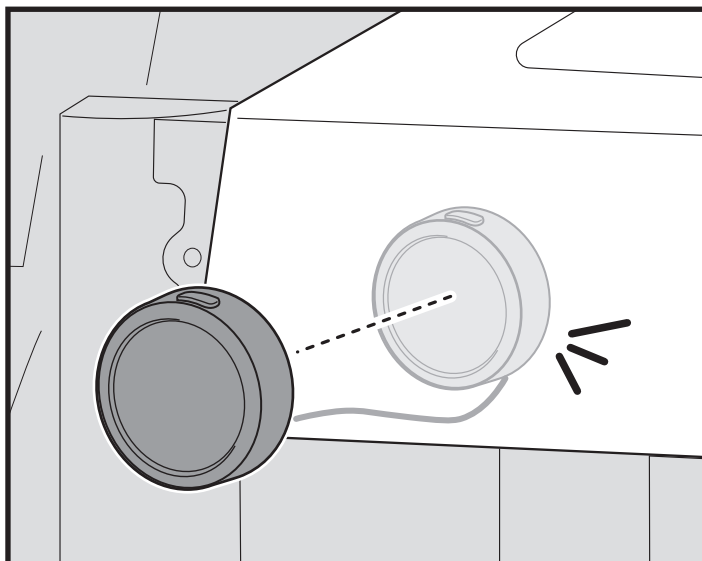
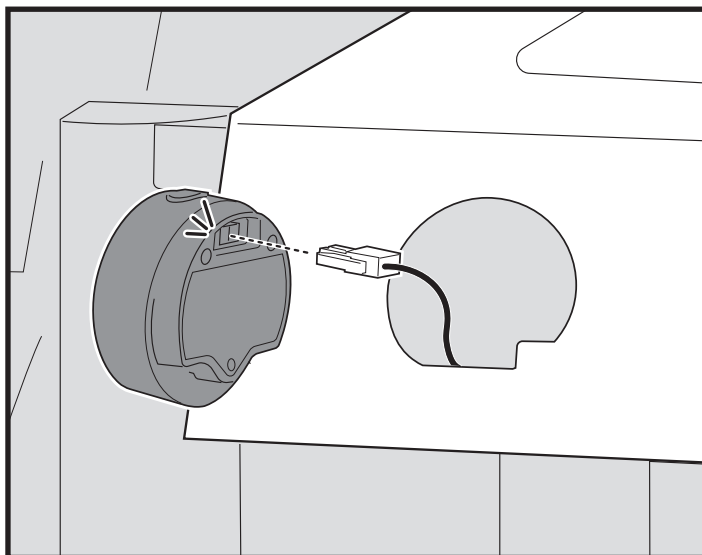

39

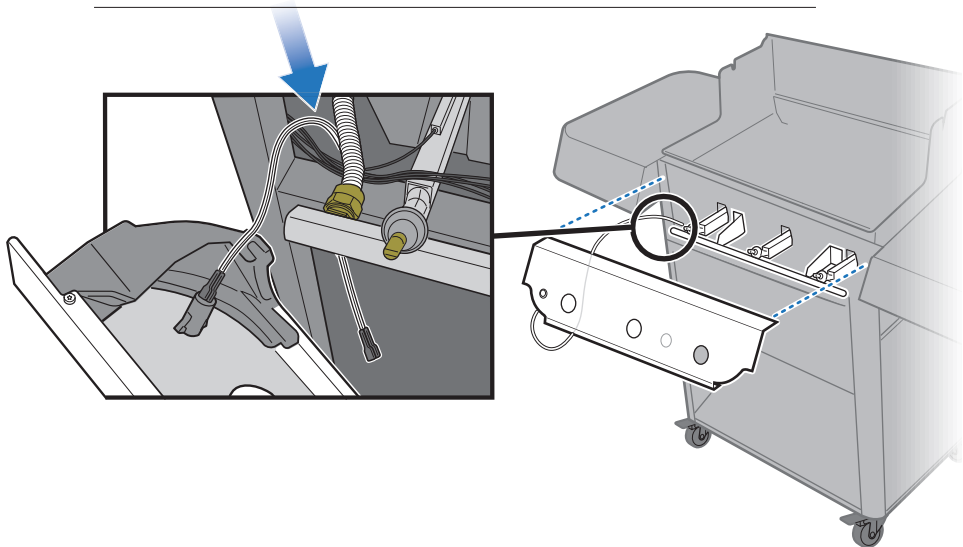
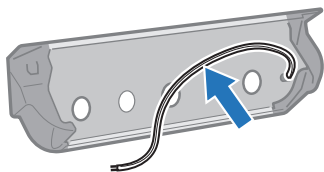

40

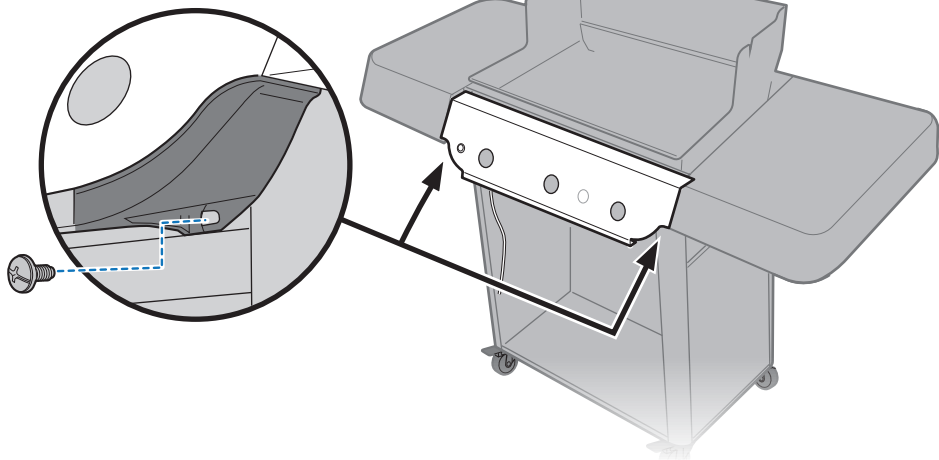

41

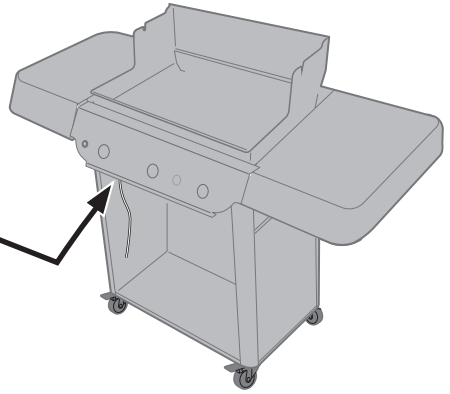
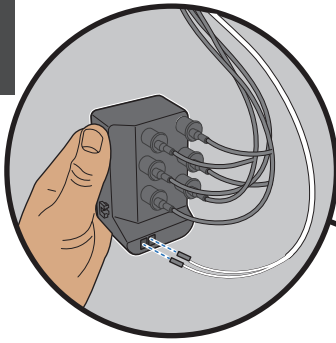

42

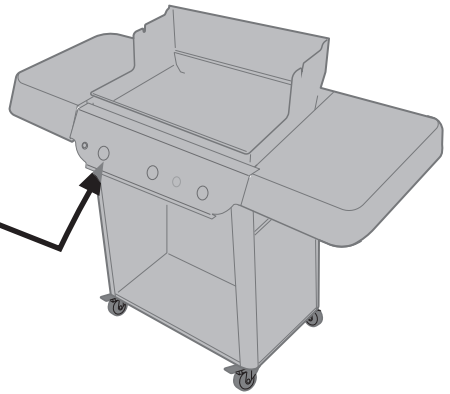
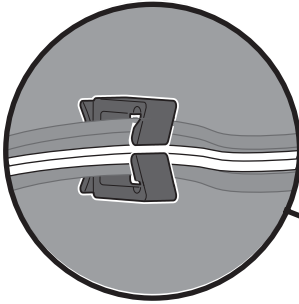

43

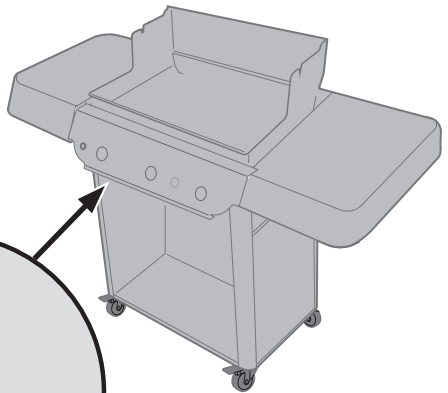
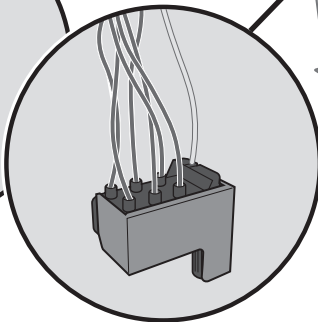
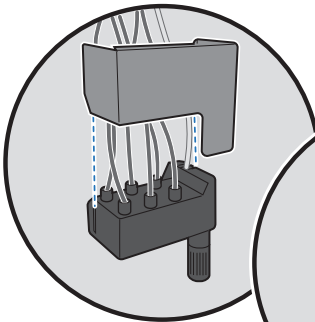

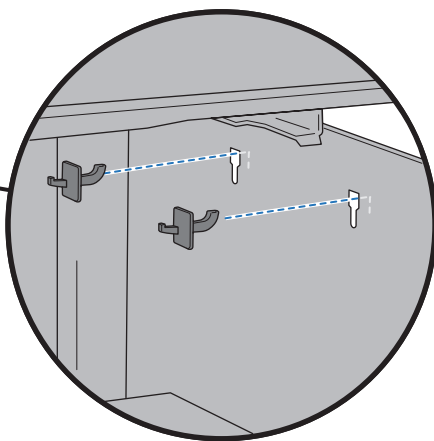
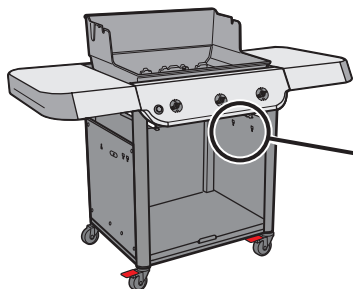
44

Raadpleeg de gebruikershandleiding voor meer kenmerken en gebruik.

Hinweise über Funktionen und Gebrauch findest du im Benutzerhandbuch.

Référez-vous au mode d'emploi pour connaître les caractéristiques et l'utilisation.

Per le caratteristiche e l'uso, consultare la Guida utente.

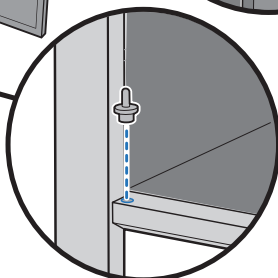
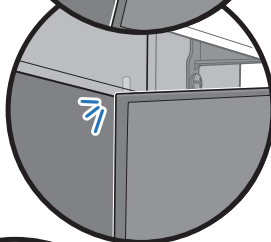
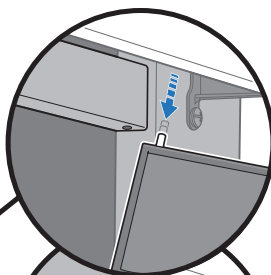
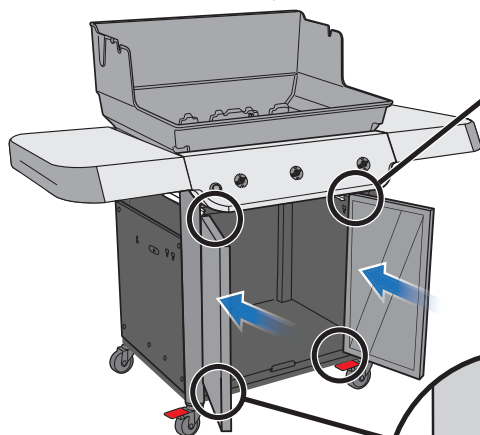
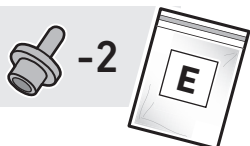
45

46

-1



Extra bevestiging(en).
Zusätzliche Befestigungselemente.
Fixation(s) supplémentaire(s).
Fascette aggiuntive.

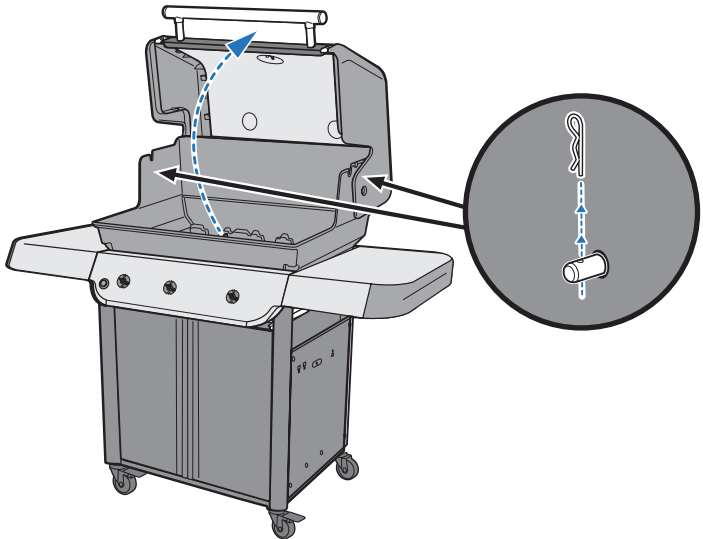
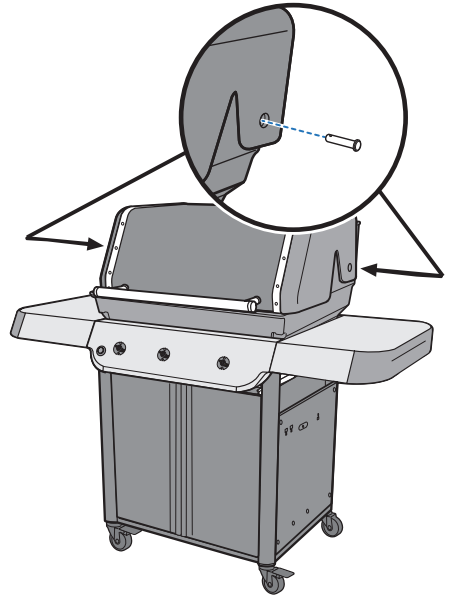
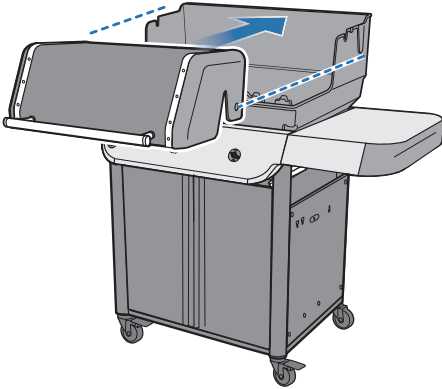

47

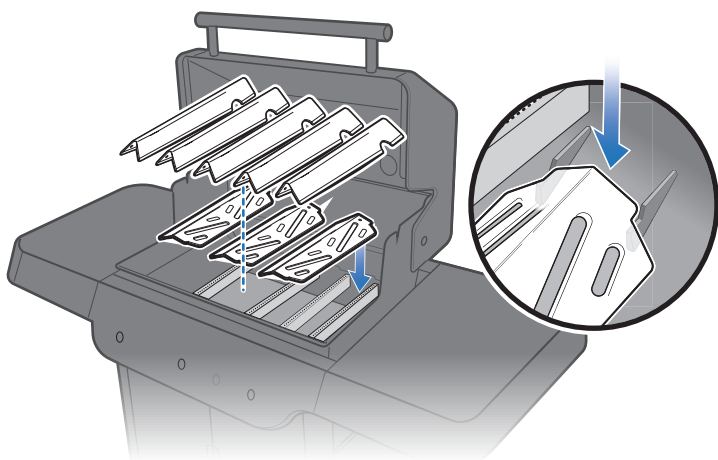

48

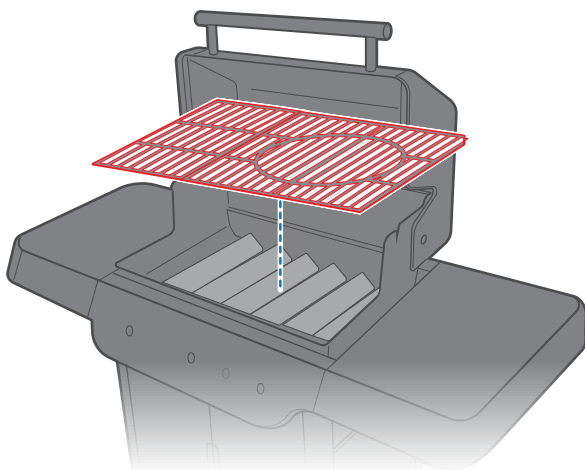

49

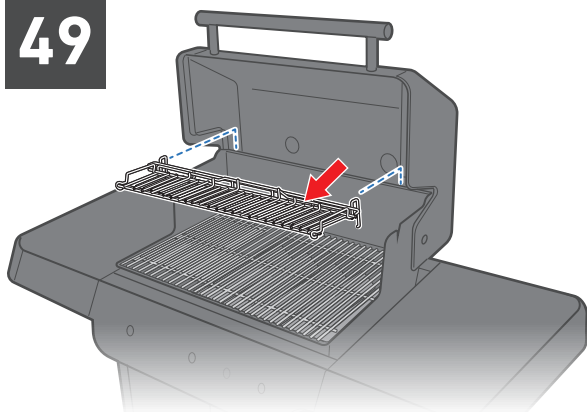

Raadpleeg de gebruikershandleiding voor meer kenmerken en gebruik.

Hinweise über Funktionen und Gebrauch findest du im Benutzerhandbuch.

Référez-vous au mode d'emploi pour connaître les caractéristiques et l'utilisation.

Per le caratteristiche e l'uso, consultare la Guida utente.

50

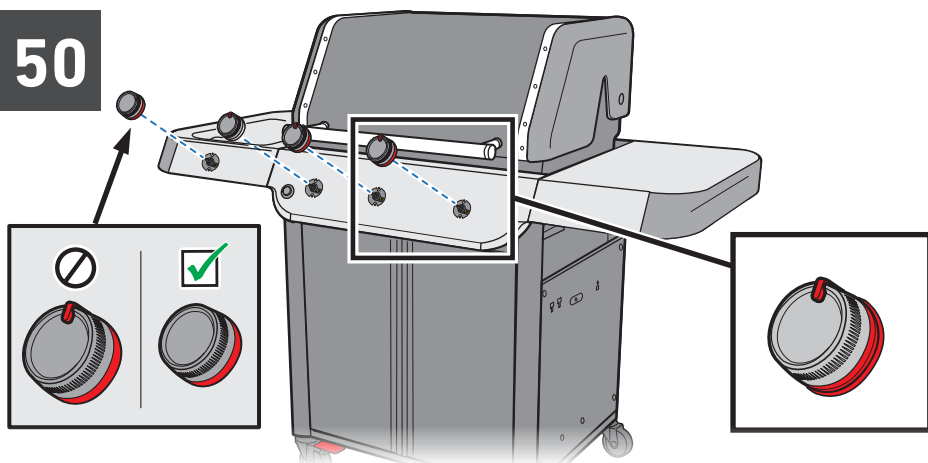

51

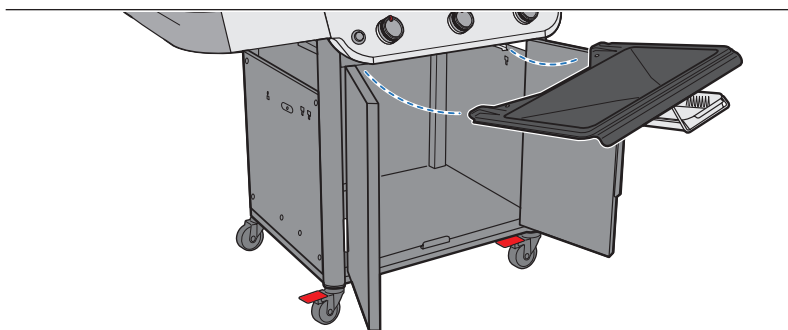
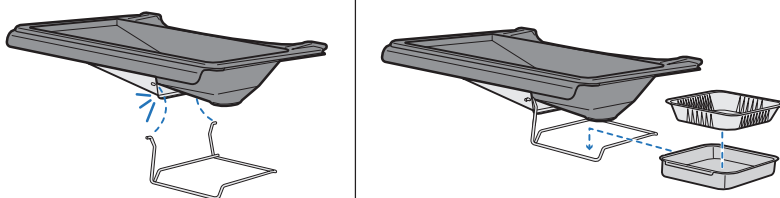

52

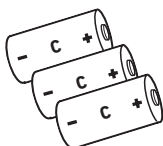

*Alleen voor
geselecteerde modellen.*

Nur für ausgewählte Modelle.

Certains modèles uniquement.

Solo per modelli selezionati.

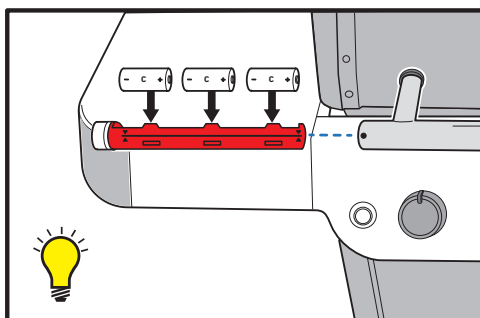

⚠ Zorg ervoor dat alle onderdelen zijn gemonteerd en de schroeven volledig zijn aangedraaid voordat je de barbecue in gebruik neemt.

⚠ Verwijder alle verpakkingsmaterialen voordat je de barbecue in gebruik neemt.

⚠ Stelle sicher, dass alle Teile ordnungsgemäß zusammengebaut und sicher befestigt sind, bevor du den Grill in Betrieb nimmst.

⚠ Entferne sämtliches Verpackungsmaterial, bevor du den Grill in Benutzung nimmst.

⚠ Assurez-vous que toutes les pièces sont assemblées et que le matériel est complètement étanche avant de mettre le barbecue en marche.

⚠ Retirez tout l'emballage avant d'allumer votre barbecue.

⚠ Prima di utilizzare il barbecue, assicurarsi che tutte le parti siano assemblate e che la minuteria sia serrata.

⚠ Prima di utilizzare il barbecue, rimuovere tutto il materiale di imballaggio.

Registreer Vandaag.

Registrieren Sie sich noch heute.

Enregistrez-le aujourd'hui.

Registrati oggi.



Apple and the Apple logo are trademarks of Apple Inc., registered in the U.S. and other countries. App Store is a service mark of Apple Inc. Android and Google Play are trademarks of Google Inc.

© 2024 Designed and engineered by Weber-Stephen Products LLC,

1415 S. Roselle Road, Palatine, Illinois 60067 USA.

www.weber.com