

REVISION HISTORY				
REV.	DATE	MODIFICATIONS	NAME	ECN NO.
A	15 MAR 2023	NEW - Spins-off from 4010046390.	Suky W.	0068827

DO NOT PRINT THIS PAGE



PRINTING SIZES

**FLAT DIMENSIONS
printed on both sides**

210 x 297 (A4)



**DELIVERED DIMENSIONS
(Stapled in the middle)**



210 x 297 (A4)

**Material: 64 g/m²
Printing: black - 1 color**

SAP REF = 2199417

Program: InDesign 2023
Black

RELEASED FOR PRODUCTION

<p>CONFIDENTIAL THIS DOCUMENT AND ITS CONTENTS ARE CONFIDENTIAL AND CONSTITUTE TRADE SECRETS PROPRIETARY TO NEWELL BRANDS, WHO RESERVE ALL RIGHTS THEREIN. BY ACCEPTING THIS DOCUMENT, THE RECIPIENT AGREES NOT TO COPY, USE, MANUFACTURE, OR COMMUNICATE TO OTHERS, WHOLLY OR IN PART, THE CONTENTS OF THIS DOCUMENT EXCEPT AS EXPRESSLY AUTHORIZED IN WRITING BY NEWELL BRANDS.</p>				<p>3 Glenlake Parkway Atlanta, GA 30328 USA</p>	
DRAWING PREPARED IN ACCORDANCE WITH ASME Y14.5		MATERIAL: SEE NOTES		FINISH: SEE NOTES	
TITLE: ASSY MANUAL 3 CLASS.WLXD					
1ST ANGLE PROJECTION		DRAWN BY: Suky W. DATE: 15 MAR 2023	SCALE: 1 : 1 SHEET 1 OF 1	DRW NO. NWL0001521743	REV A

3 Series Classic WLXD

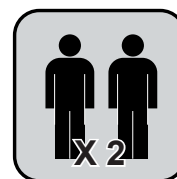
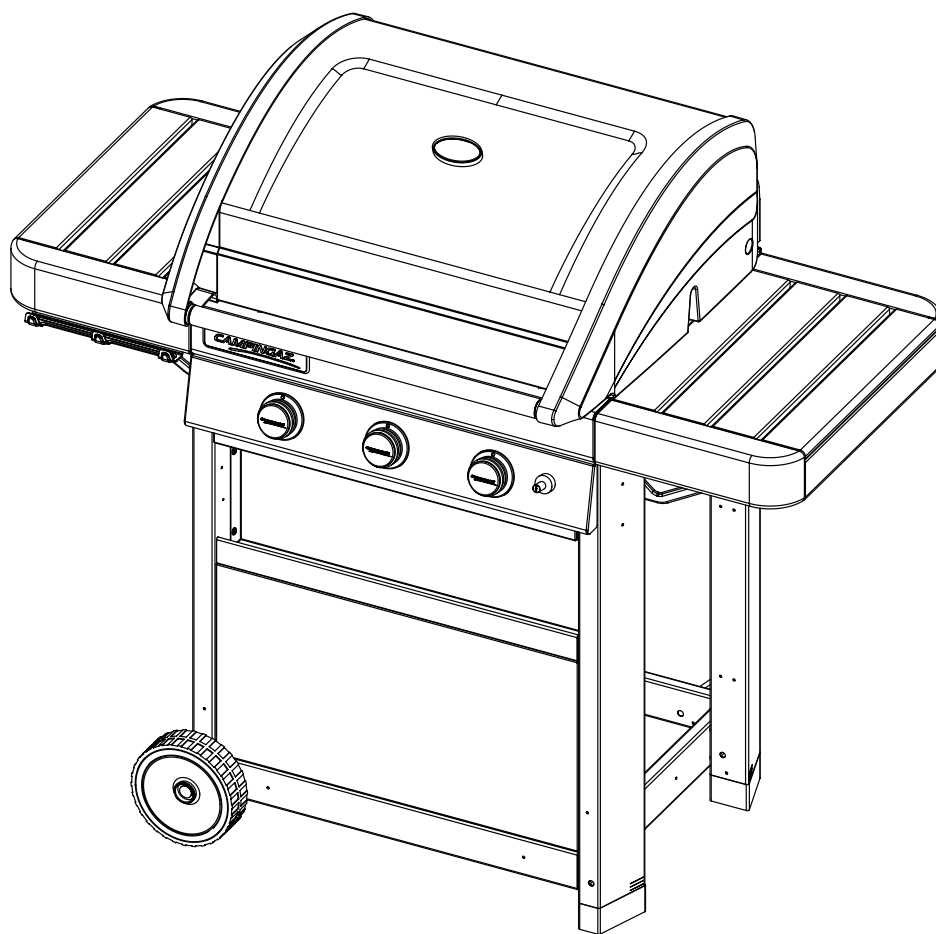

FR Instructions de montage

GB Assembly instructions

DE Montageanleitung

NL Montage-instructies

IT Istruzioni per il montaggio

ES Instrucciones de montaje

PT Instruções de montagem

NO Monteringsinstrukser

DK Monteringsvejledning

SE Monteringsanvisningar

FI Kokoamisohjeet

PL Instrukcja montażu

CZ Návod k montáži příložen

SI Navodila za montažo

SK Návod na montáž

HU Összeszerelési-és használati utasítás

HR Upute za montiranje

RO Instrucțiuni de montaj







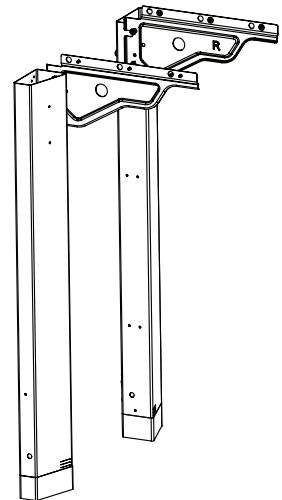
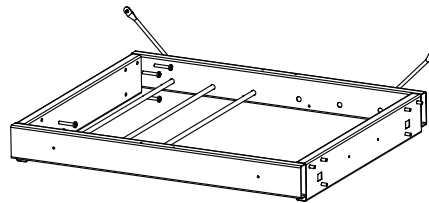
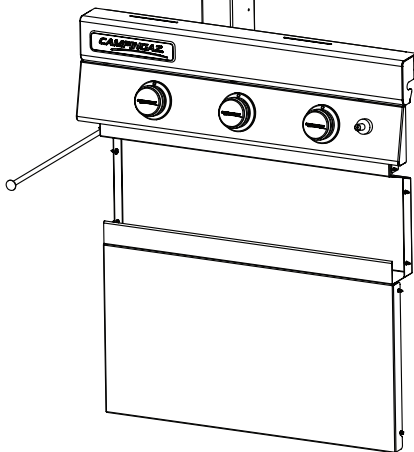
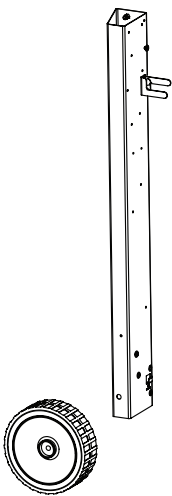
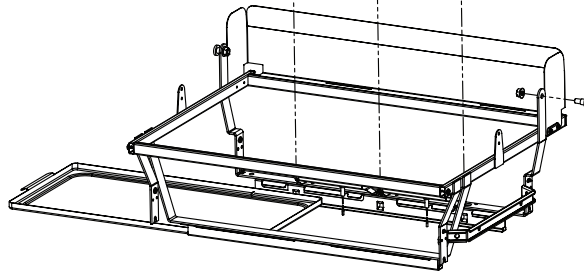
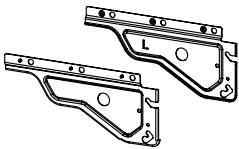
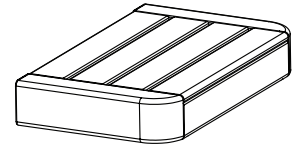
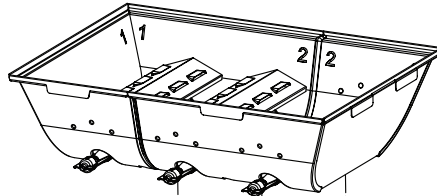
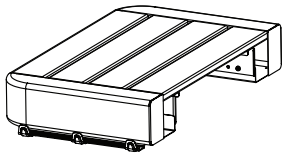
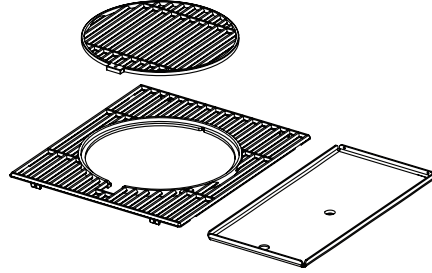
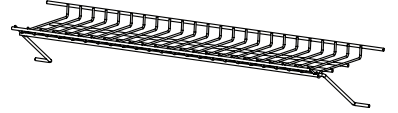
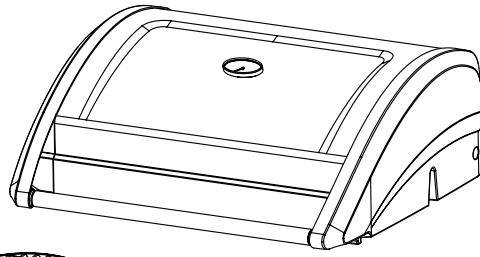

BG Указания за монтаж

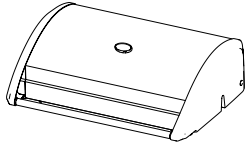
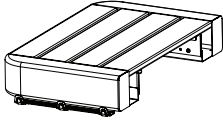
TR Montaj

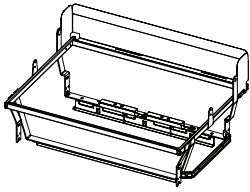
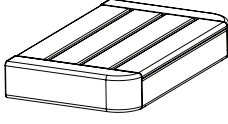
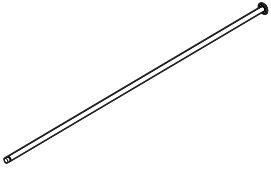
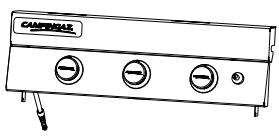
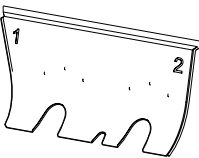
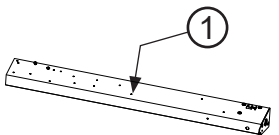
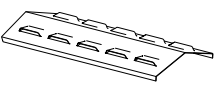
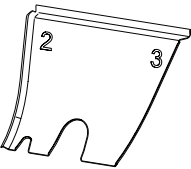
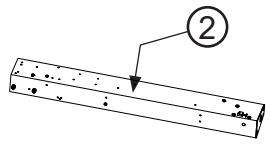
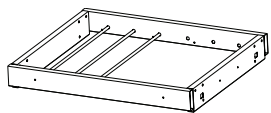
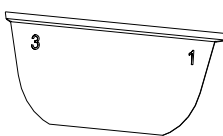
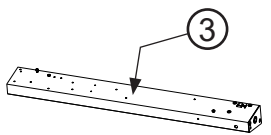
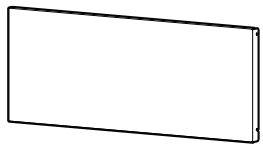
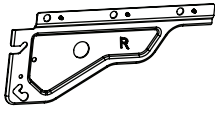
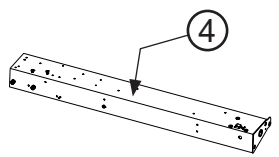

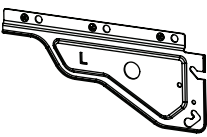
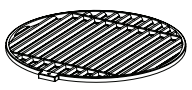
GR Οδηγίες συναρμολόγησης

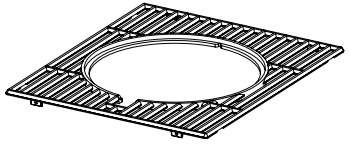

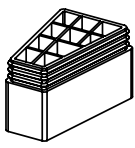
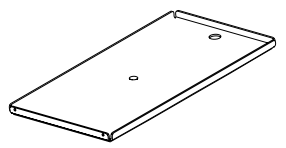

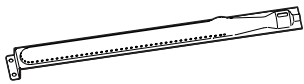

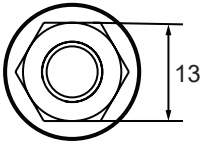
3 CLASSIC WLXD		3 CLASSIC WLXD		3 CLASSIC WLXD	
1		1		2	
1		1		1	
1		2		1	
2		2		1	
1		2		1	
1		2		1	
1		2		1	
1		1		1	
1		1		3	

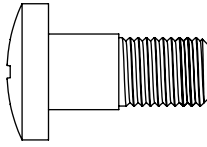
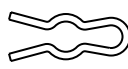
3 CLASSIC WLXD	
3	

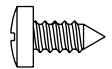
3 CLASSIC WLXD		1:1		
2		13		- b
12				- c
2				- d
1				

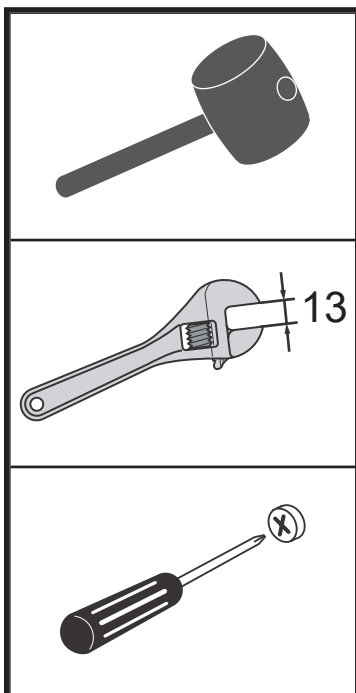
3 CLASSIC WLXD		1:1		
42				- a

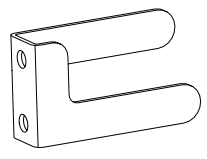
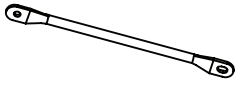
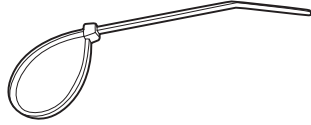
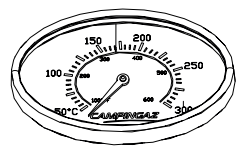

3 CLASSIC WLXD		
1		
2		
2		
1		



- FR** - Ce produit est conçu pour un usage privé ordinaire, et non pour un usage professionnel.
- GB** - This product is designed for a normal private use, not intended for commercial purposes.
- DE** - Dieses Produkt wurde für den gewöhnlichen privaten Gebrauch entwickelt. Es ist nicht für den gewerblichen Gebrauch bestimmt.
- NL** - Dit product is ontworpen voor normaal particulier gebruik en is niet bedoeld voor commerciële doeleinden.
- IT** - Questo prodotto è indicato per uso privato normale, non è indicato per scopi commerciali.
- ES** - Este producto ha sido diseñado para uso personal normal, no para uso comercial.
- PT** - Este produto foi concebido para um uso particular normal, não destinado a fins comerciais.
- NO** - Dette produktet er ment til normal, privat bruk og skal ikke brukes til kommersielle formål.
- DK** - Dette produkt er beregnet til en normal privat brug og ikke beregnet til kommercielle formål.
- SE** - Den här produkten har konstruerats för normalt privat bruk. Den är inte avsedd för kommersiella ändamål.
- FI** - Tämä tuote on tarkoitettu normaaliin yksityiskäyttöön, eikä sitä ei ole tarkoitettu kaupallisiin tarkoituksiin.
- PL** - Niniejszy produkt został zaprojektowany pod kątem zastosowań prywatnych i nie jest przeznaczony do intensywnej pracy ciągłej, typowej dla zastosowań profesjonalnych lub komercyjnych.
- CZ** - Tento výrobek je určen pro běžné domácí použití, není určen pro komerční účely.
- SI** - Ta izdelek je zasnovan za običajno zasebno uporabo in ni predviden za komercialne namene.
- SK** - Tento výrobok je určený na bežné súkromné použitie, nie na komerčné účely.
- HU** - A terméket normál, magáncélú használatra tervezték; kereskedelmi célú használatra nem alkalmas.
- HR** - Ovaj je proizvod proizveden za normalnu upotrebu u privatne svrhe, nije namijenjen za upotrebu u komercijalne svrhe.
- RO** - Acest produs este destinat utilizării private normale, nu pentru spații comerciale.
- BG** - Този продукт е предназначен за стандартно индивидуално ползване. Не е предназначен за търговски цели.
- TR** - Bu ürün normal kişisel kullanım için dizayn edilmiştir, ticari amaçlı kullanıma uygun değildir.
- GR** - Το προϊόν αυτό είναι σχεδιασμένο για κανονική ιδιωτική χρήση και δεν προορίζεται για εμπορικούς σκοπούς.

01

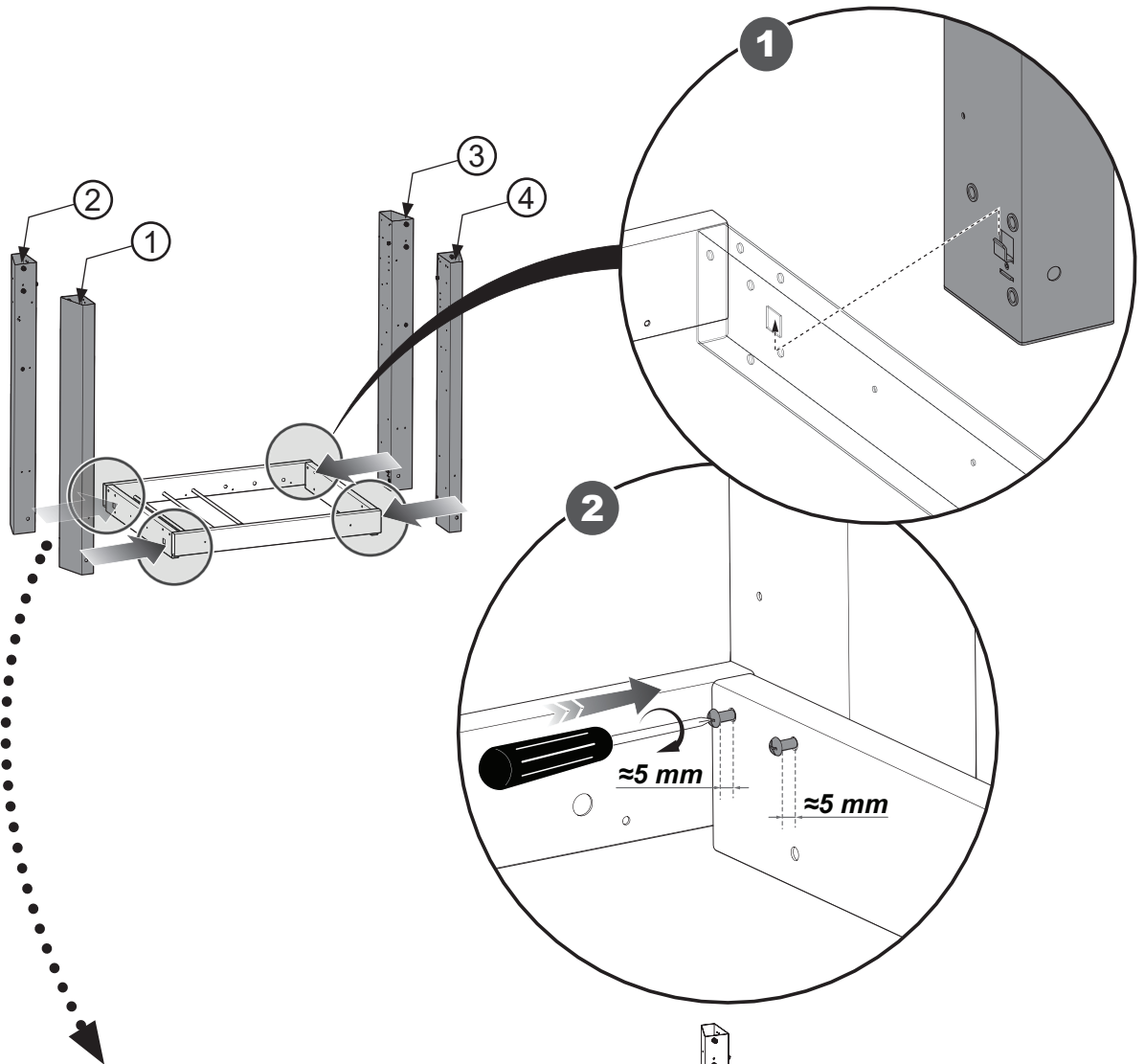

1a

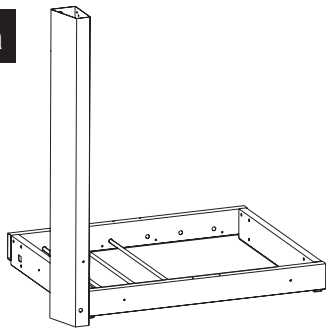

1b

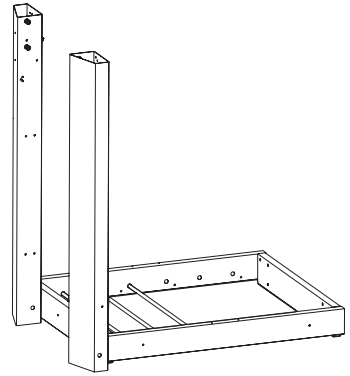
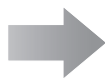

1c

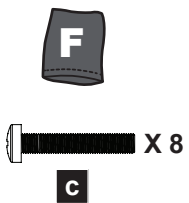
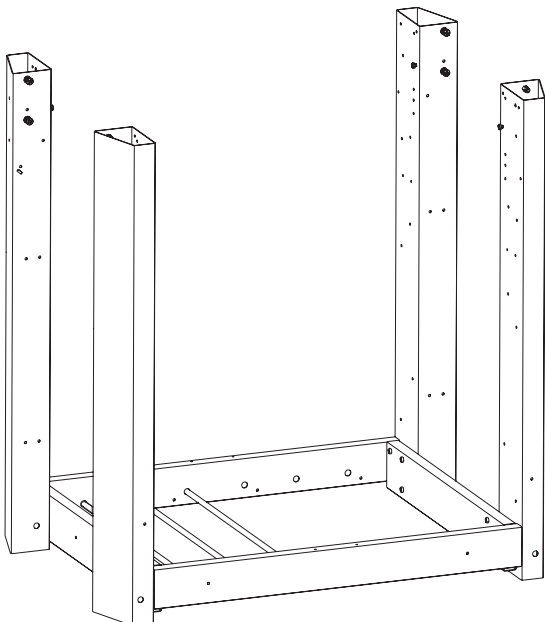

02

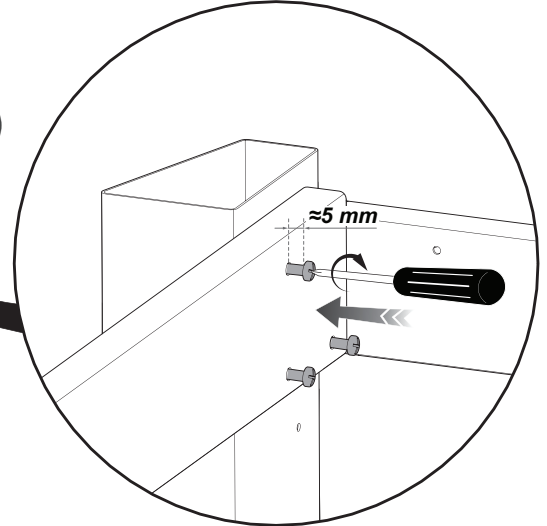
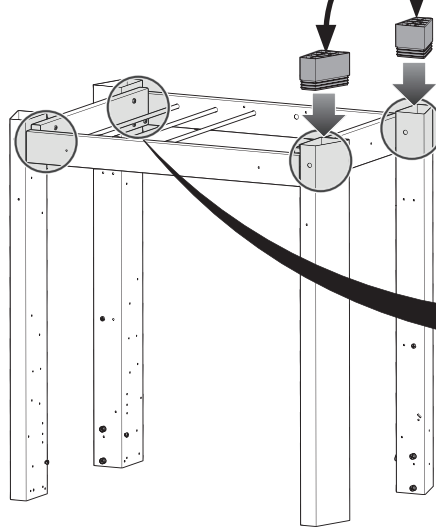
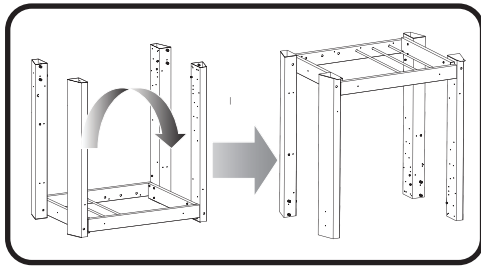
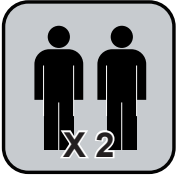

03

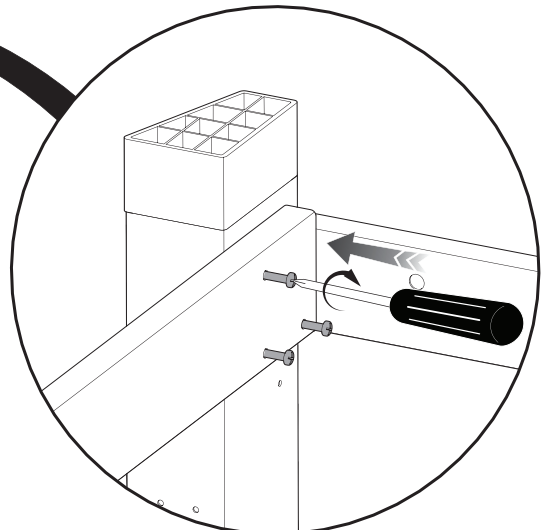
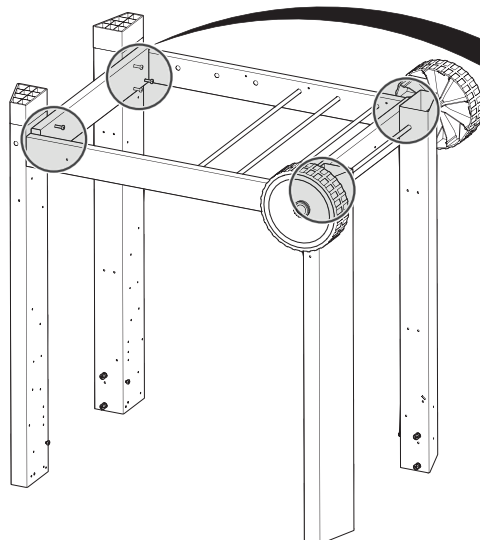
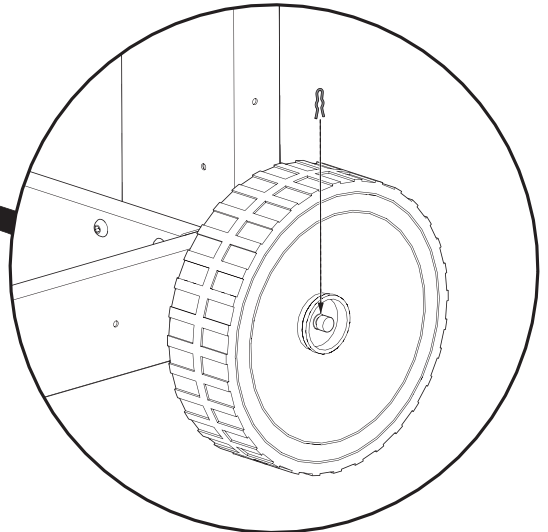
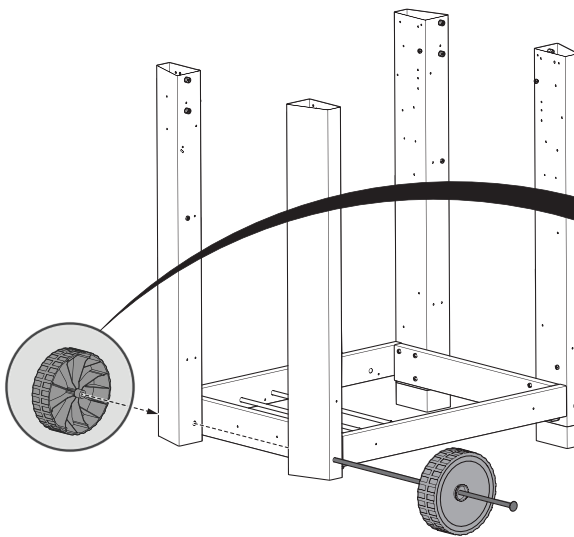

04



X 4

a

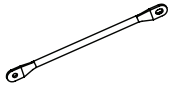

X 2

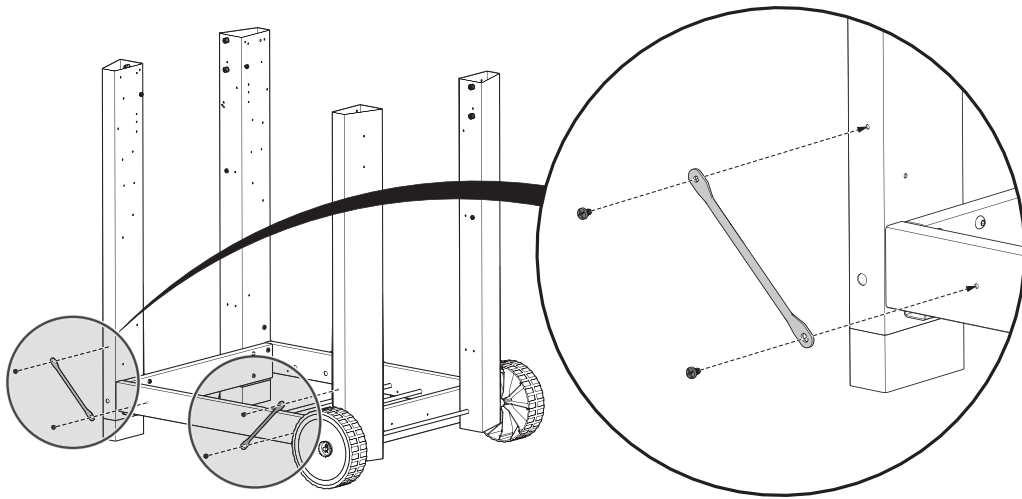

05

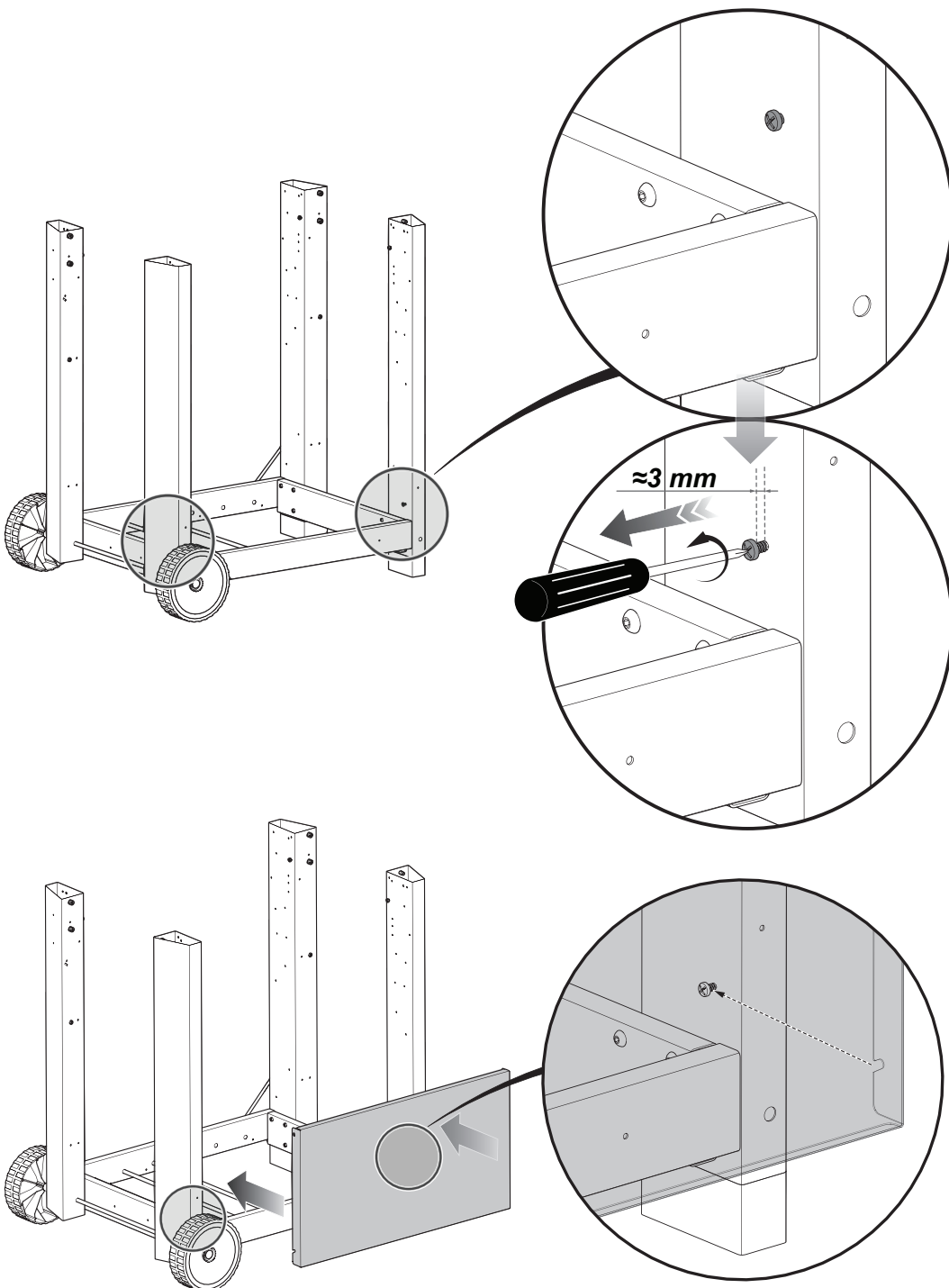

06



 X 2

a

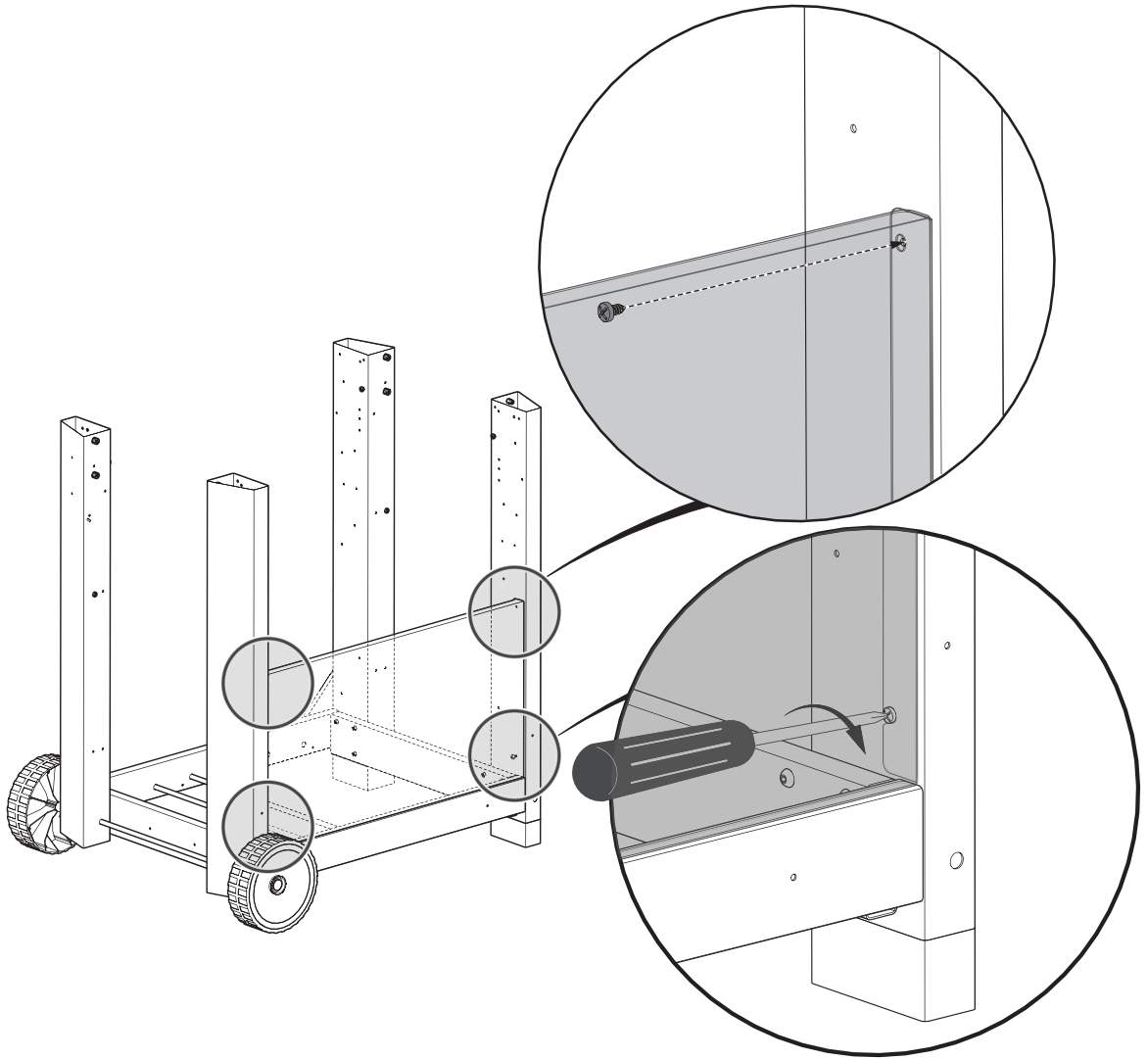

07



 X 1



 X 2

a

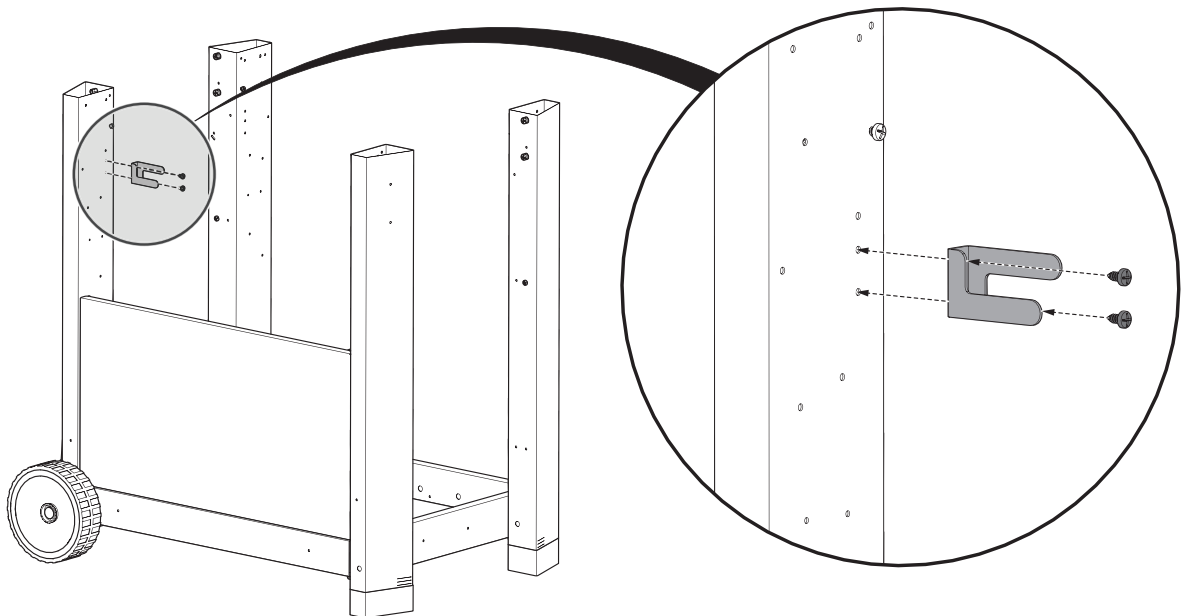

08

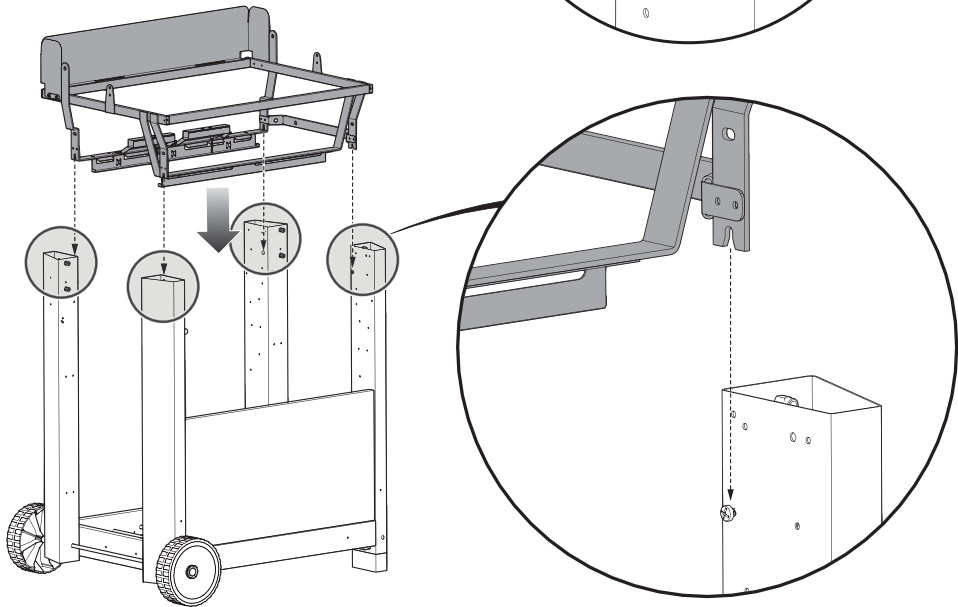
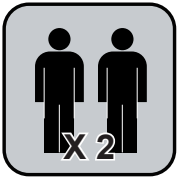
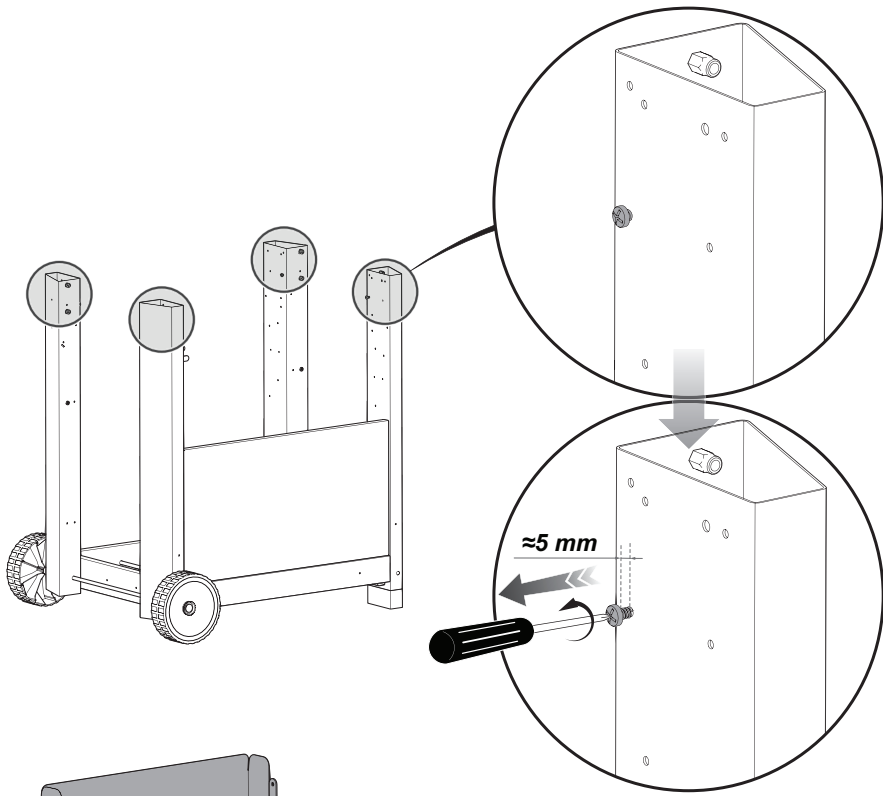

X 4

a

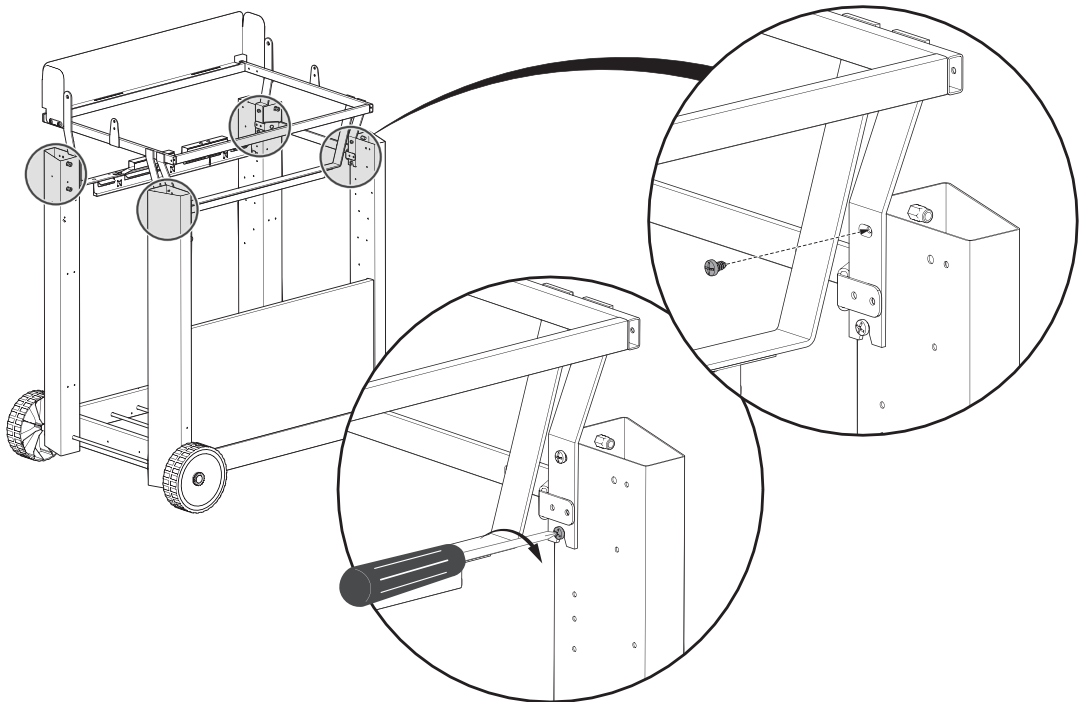

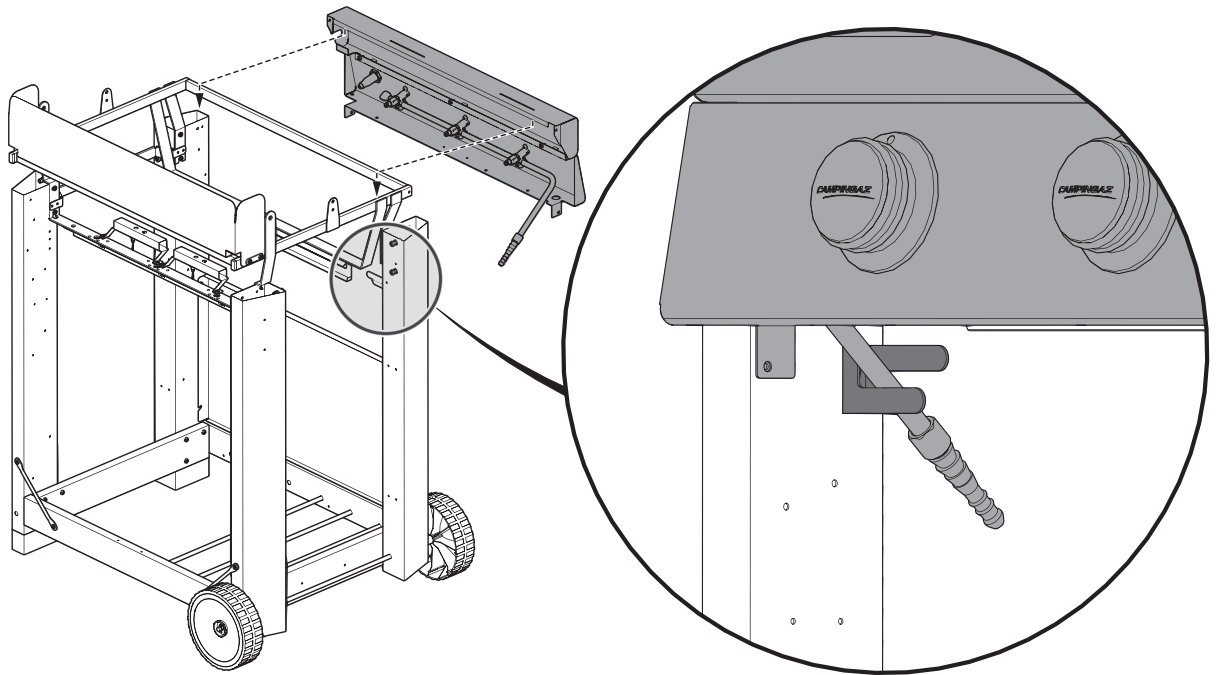

J

 X 4

a

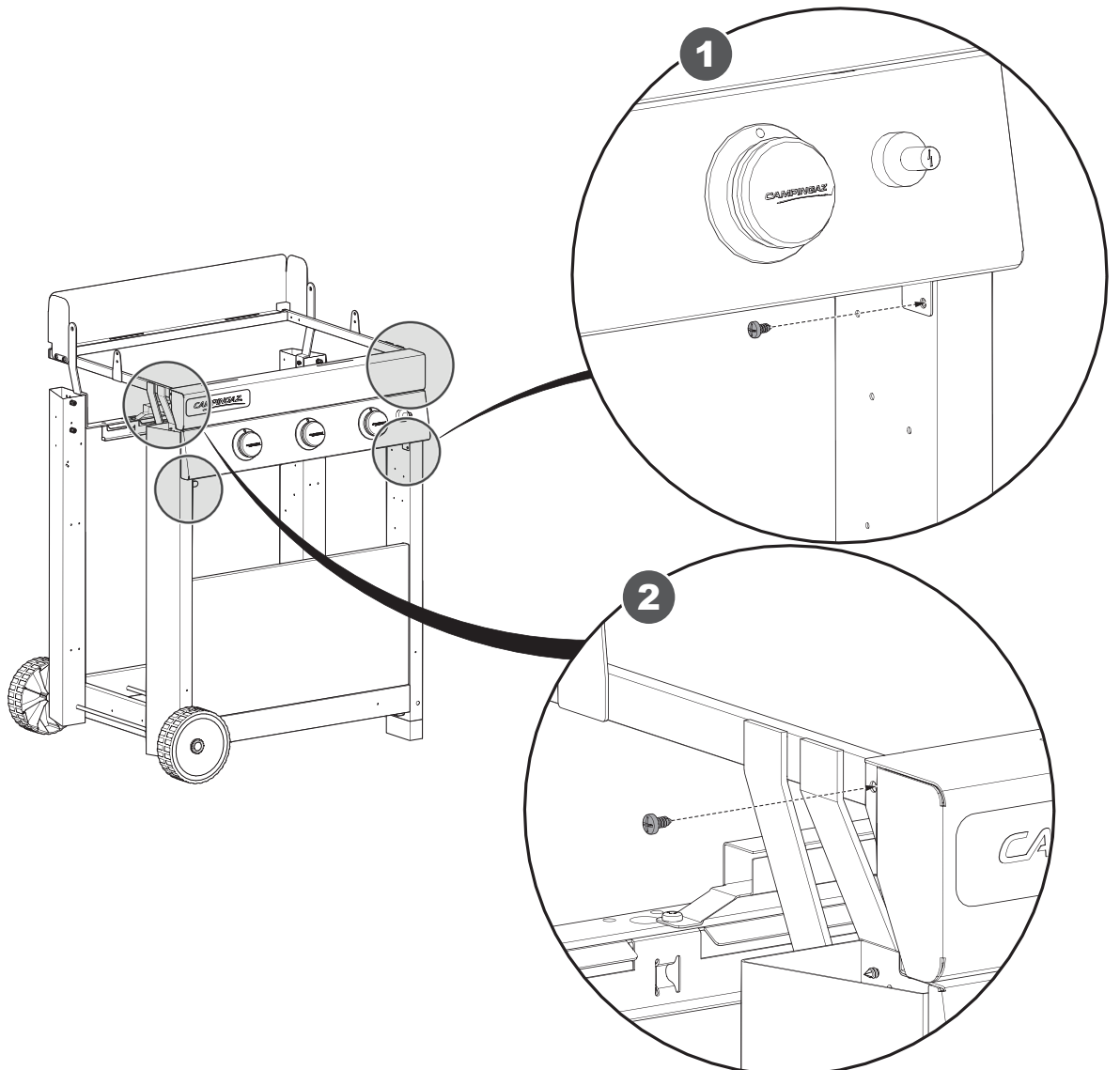

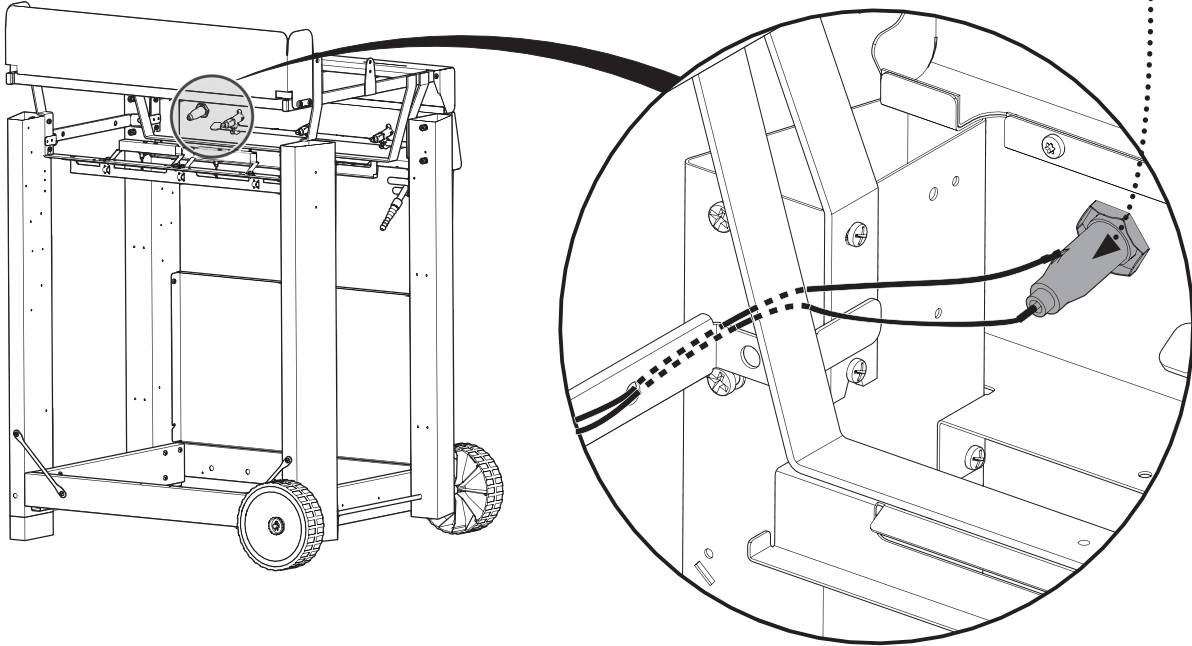
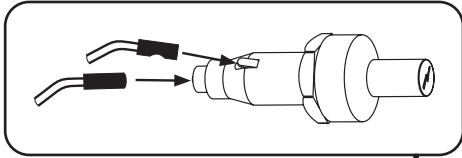
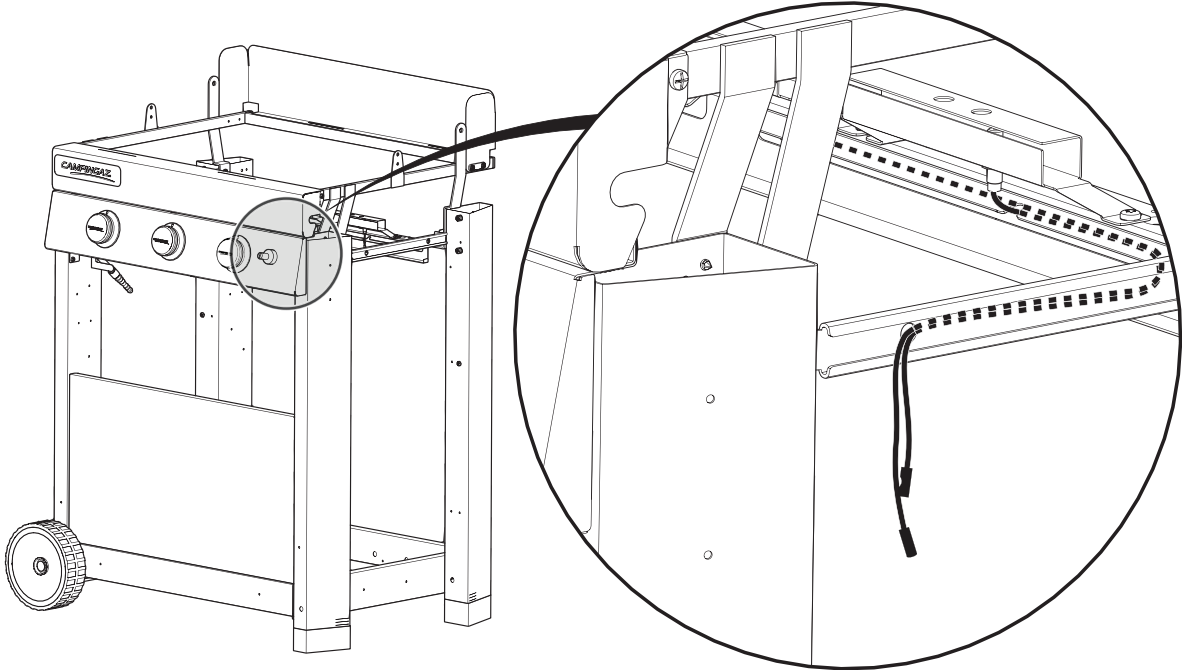

11

J

 X 6

a

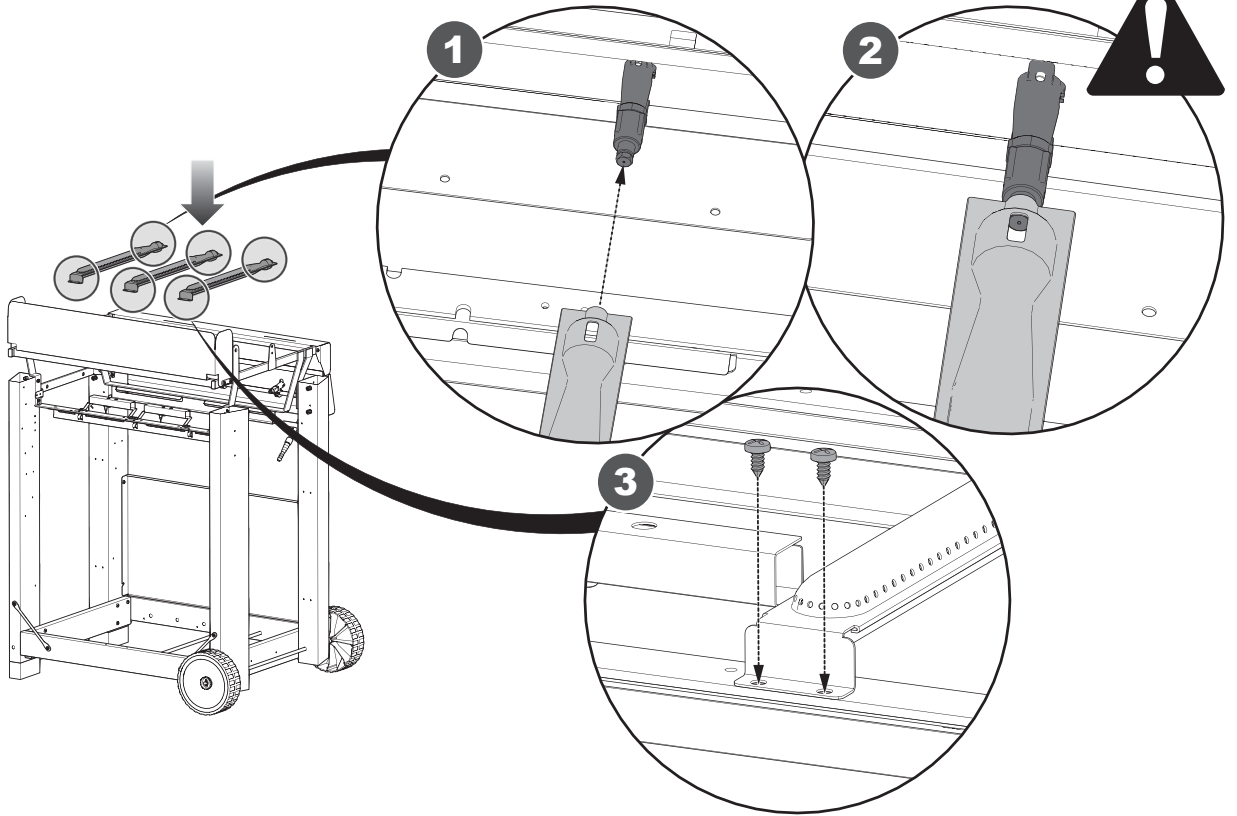

12

J

 X 4

a

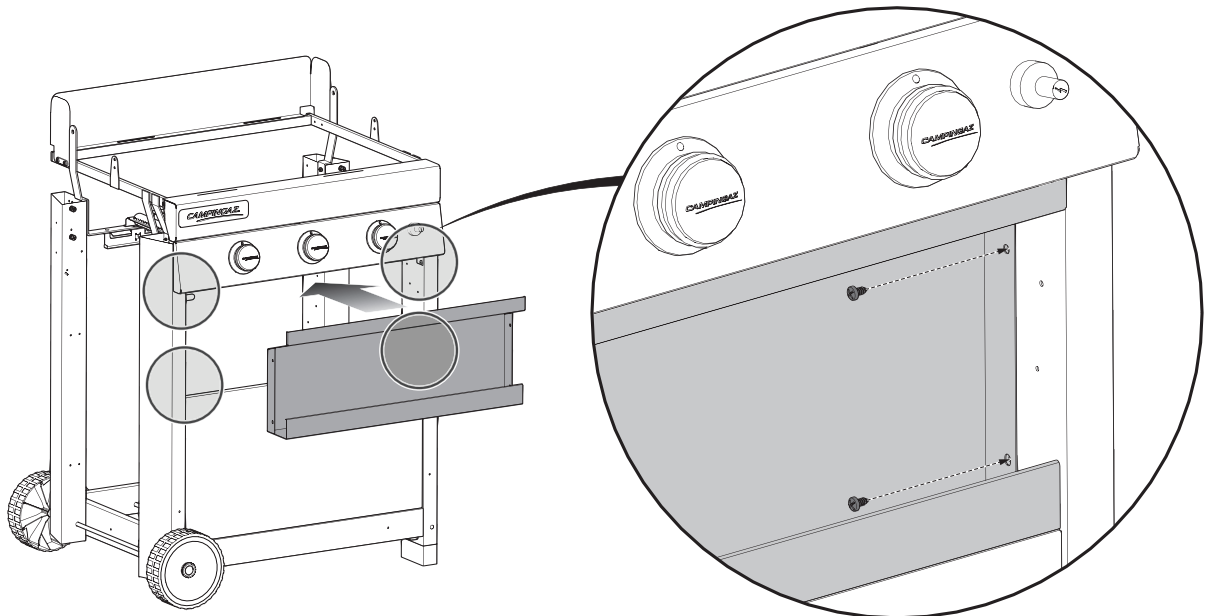

13



 X 12

a

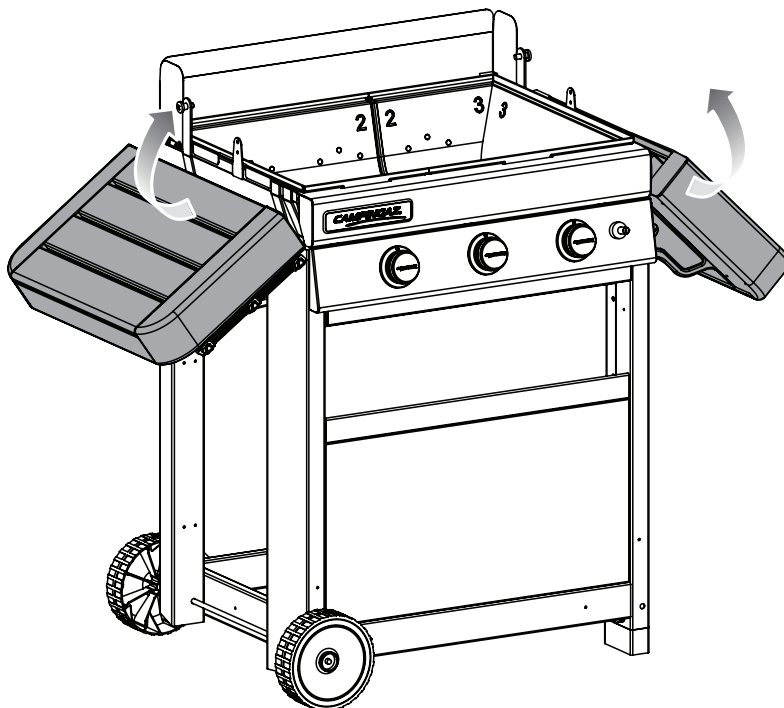
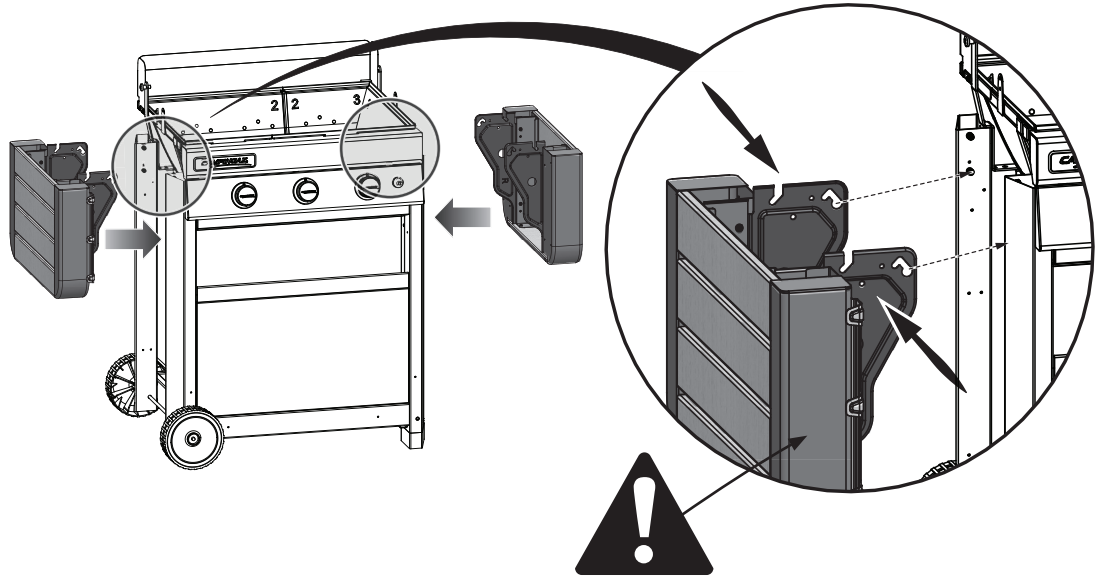
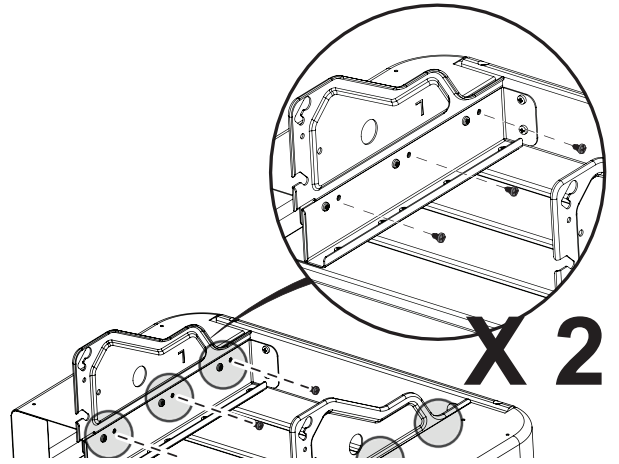
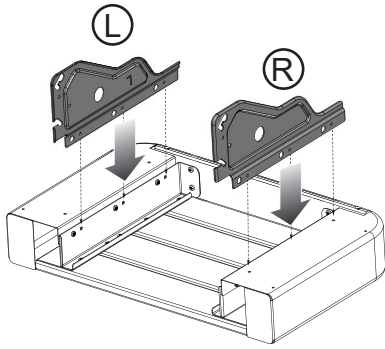

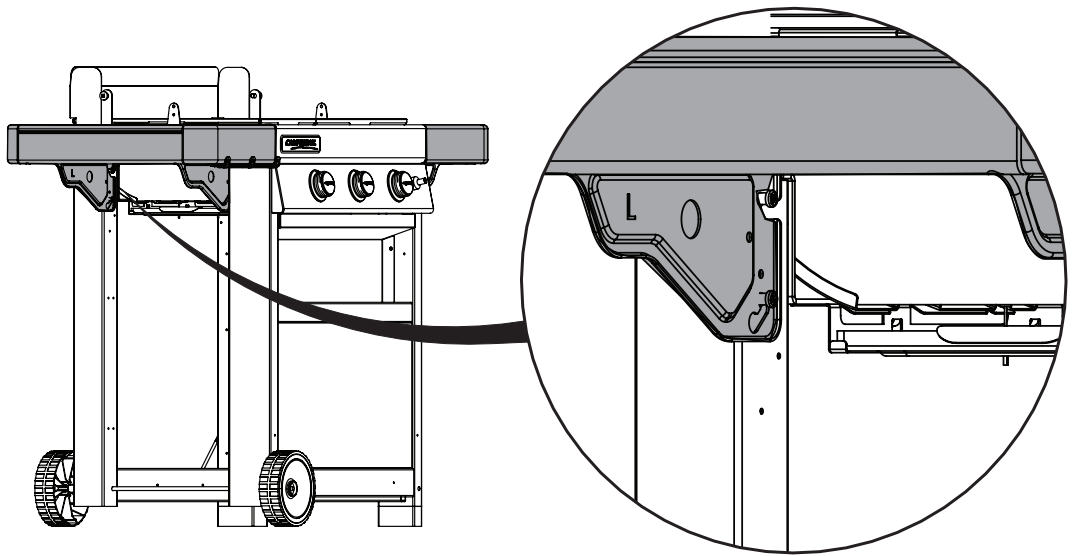

OPTION 1

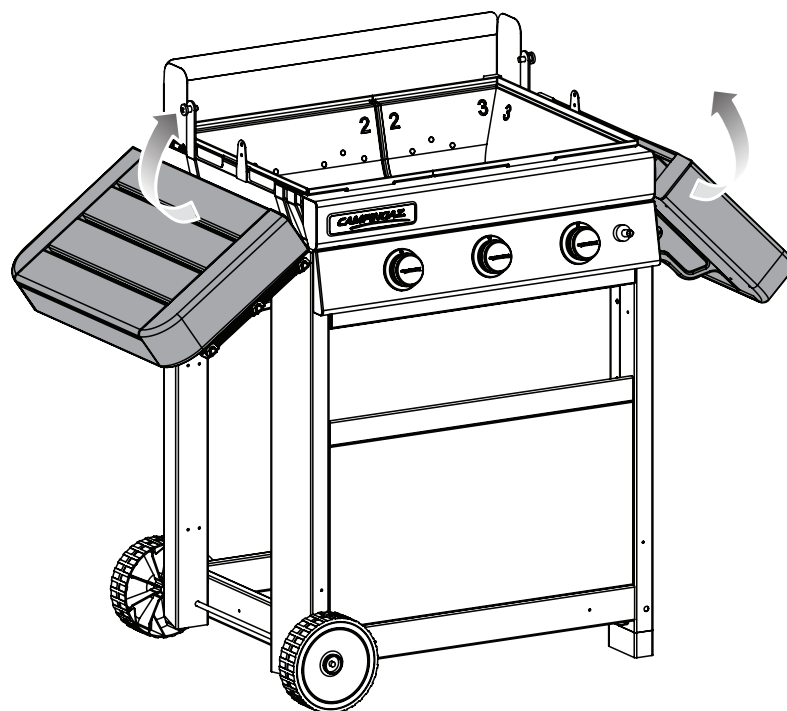

OPTION 2

J

X 4

a

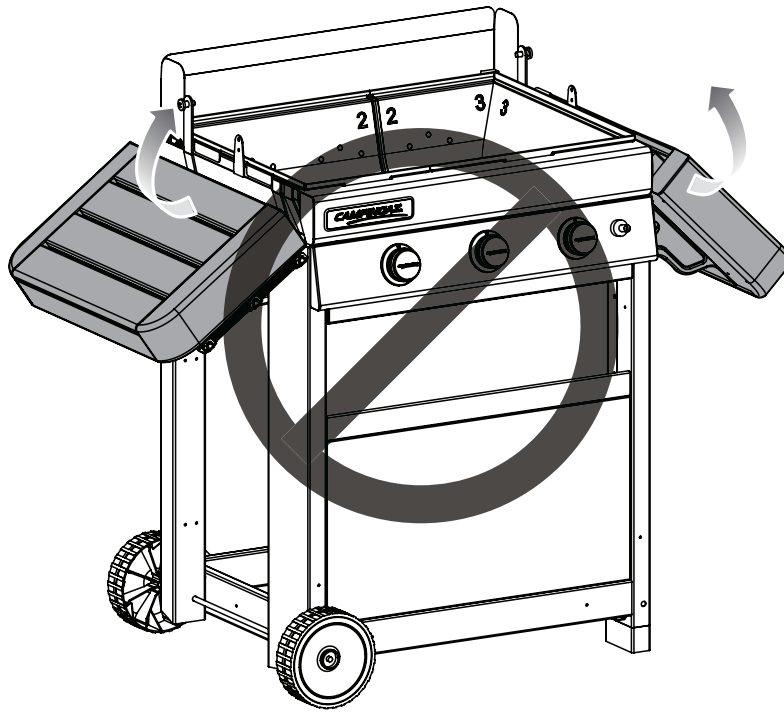
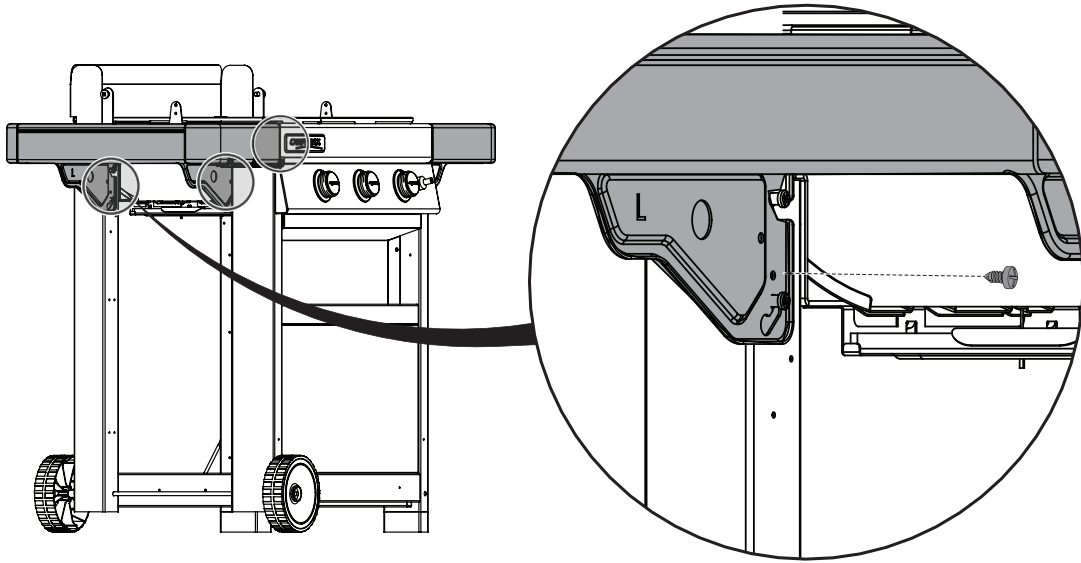

14

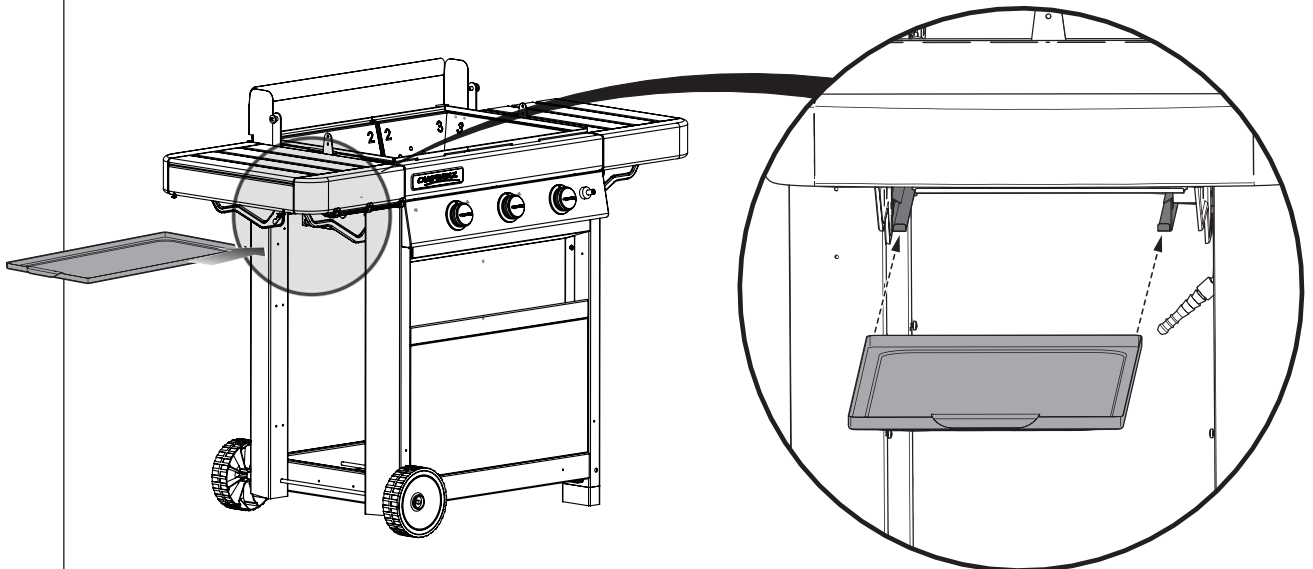

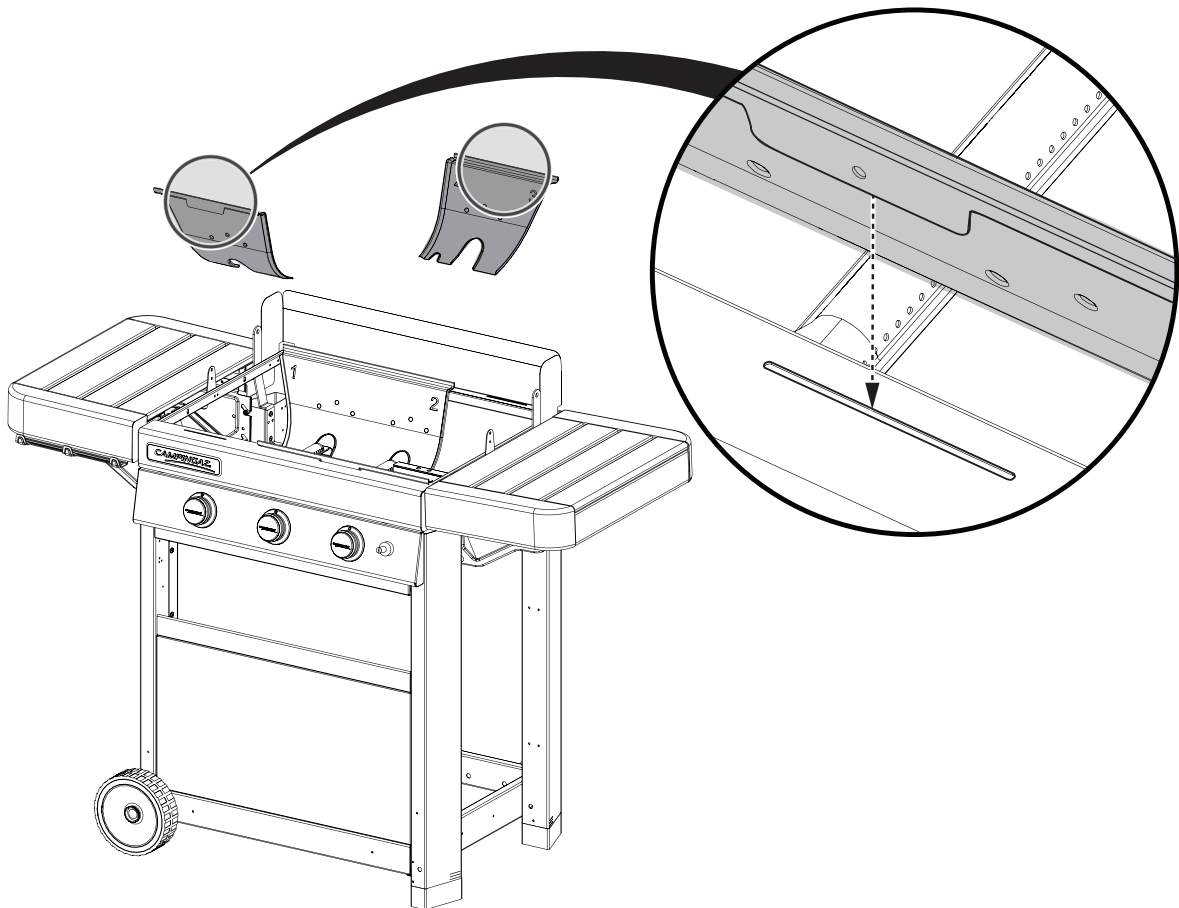
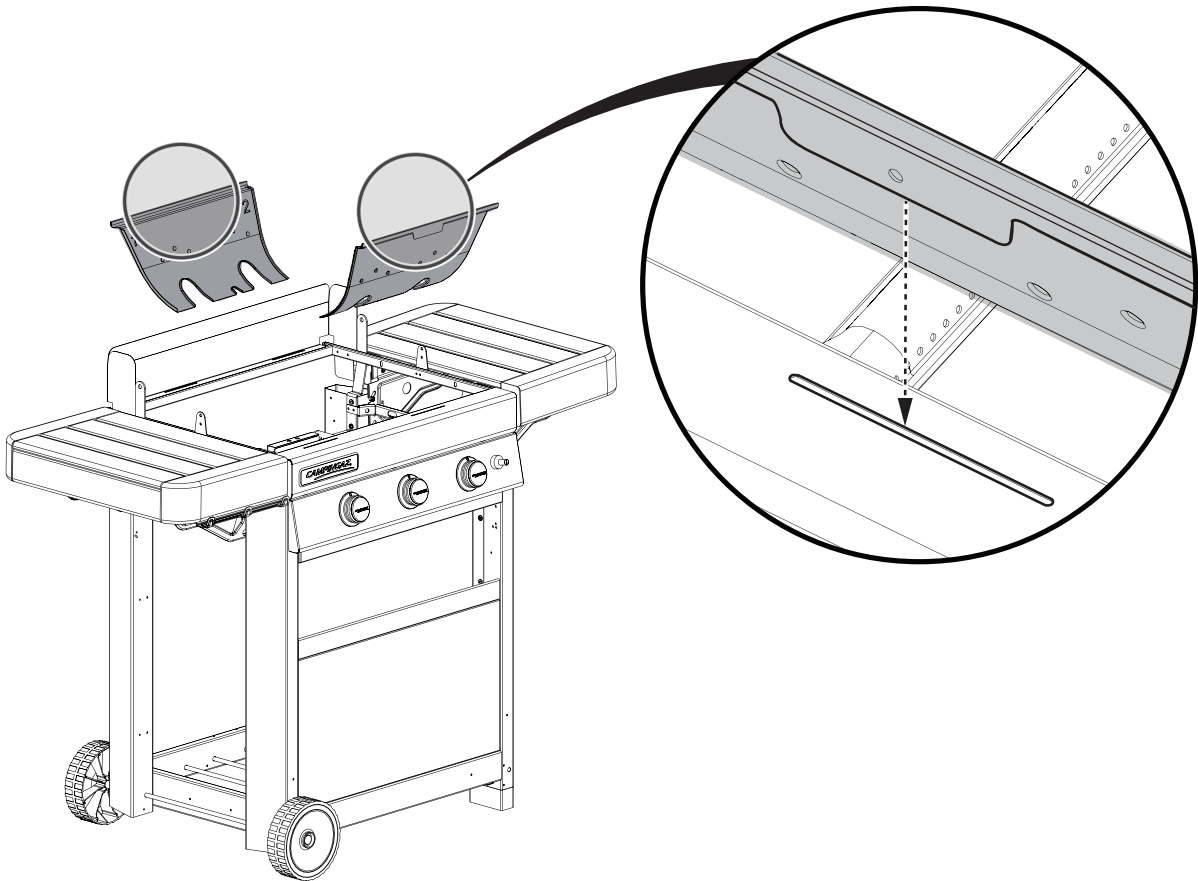

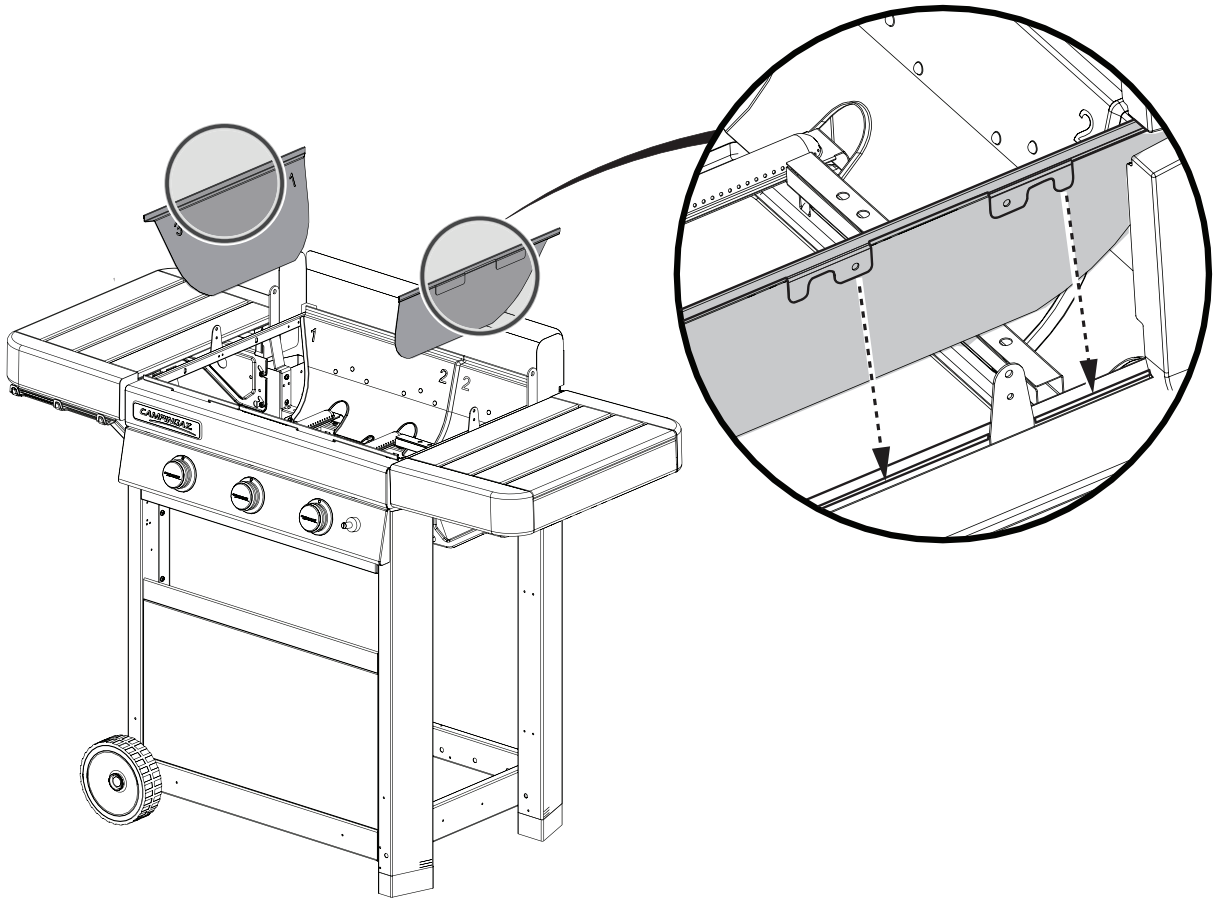

16

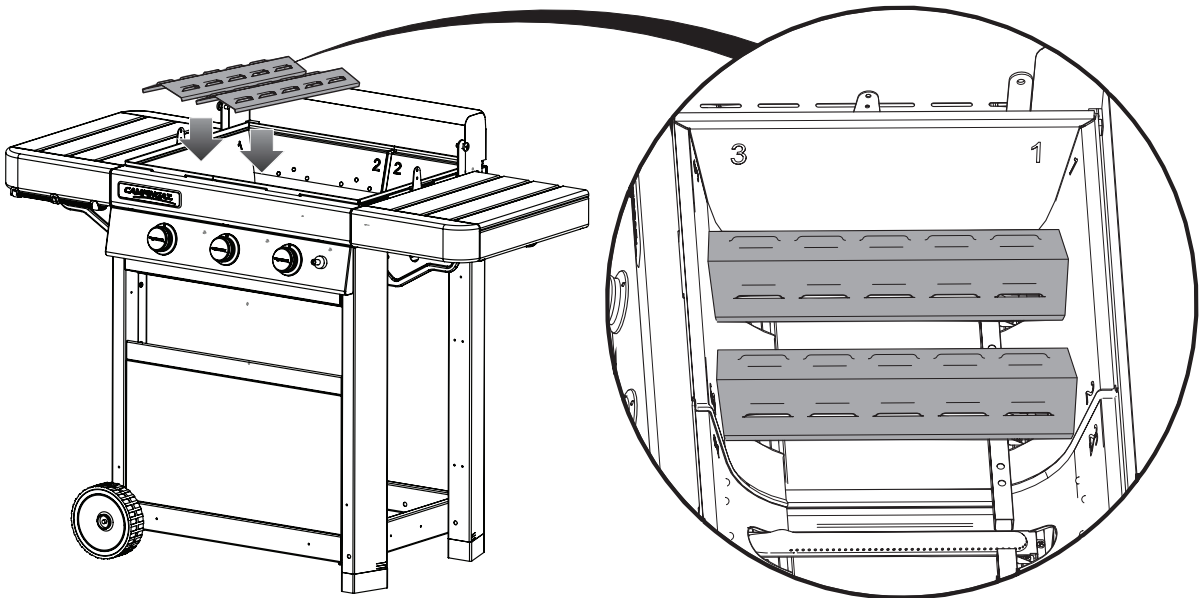

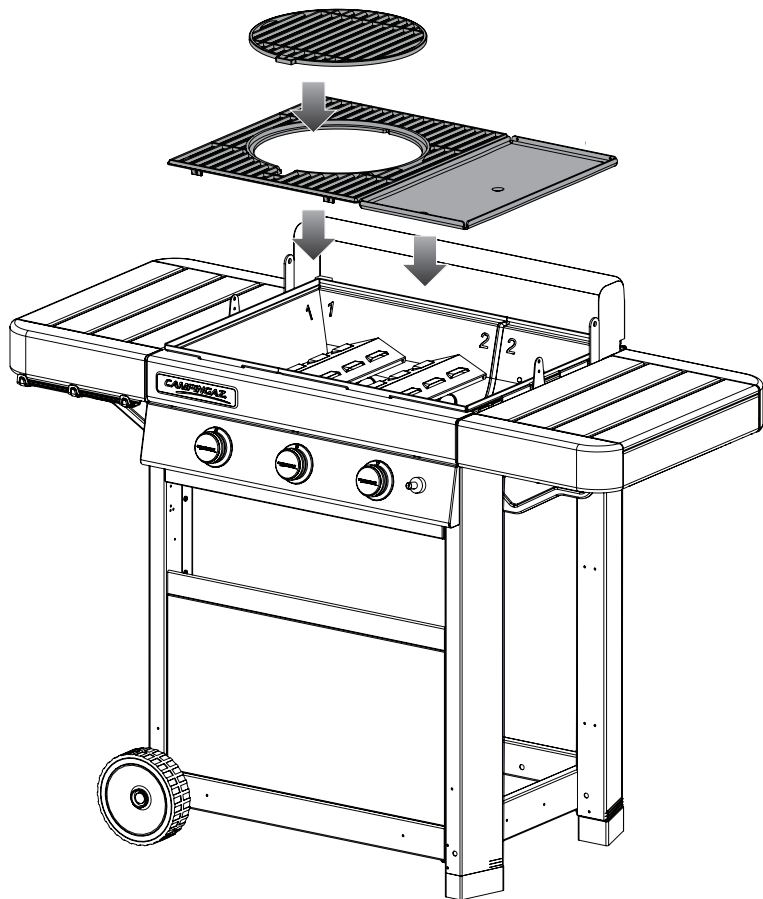

17

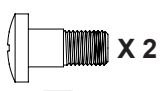
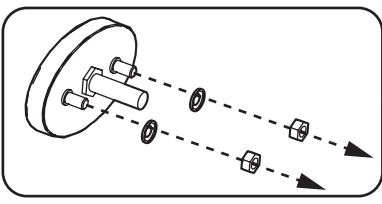
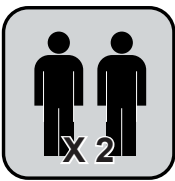

d



b



X 1

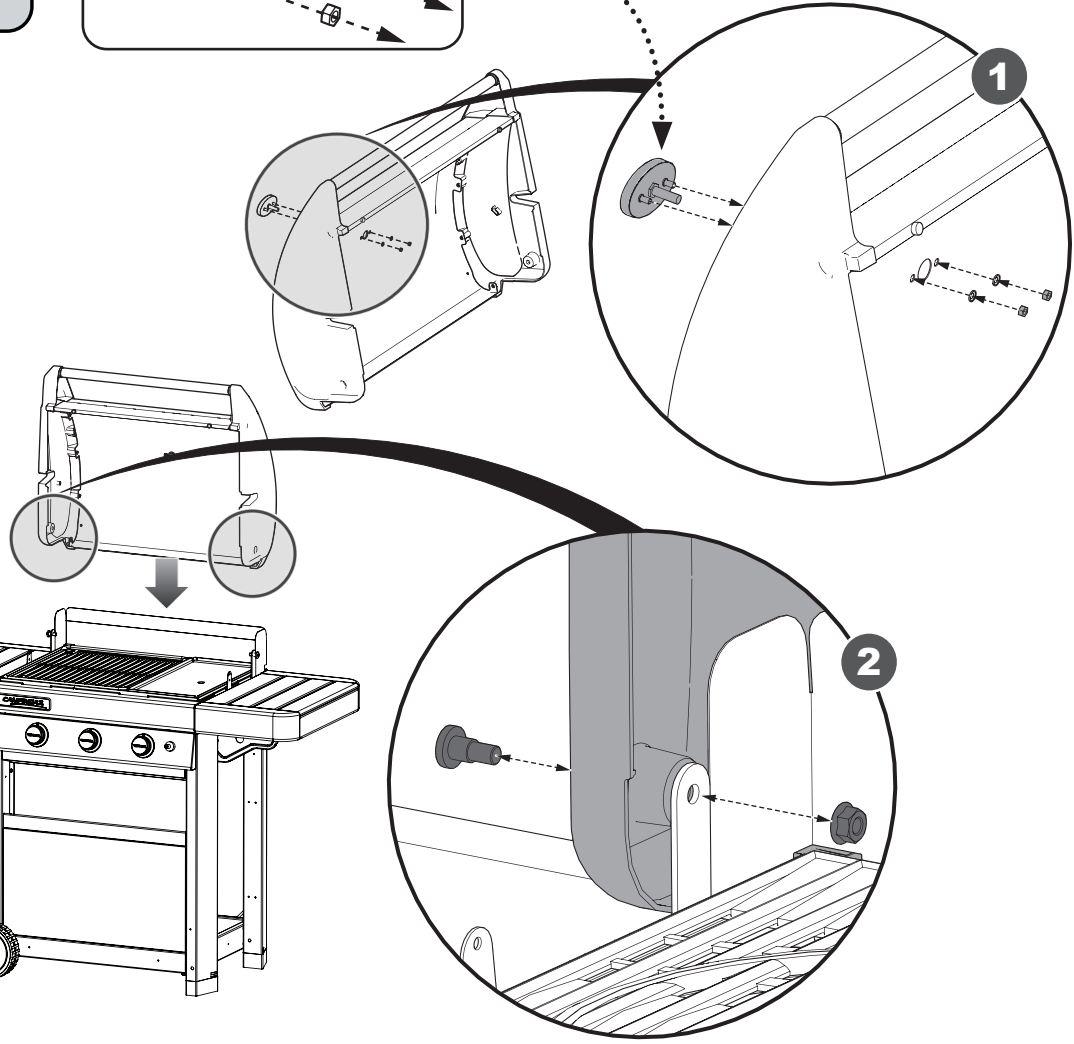

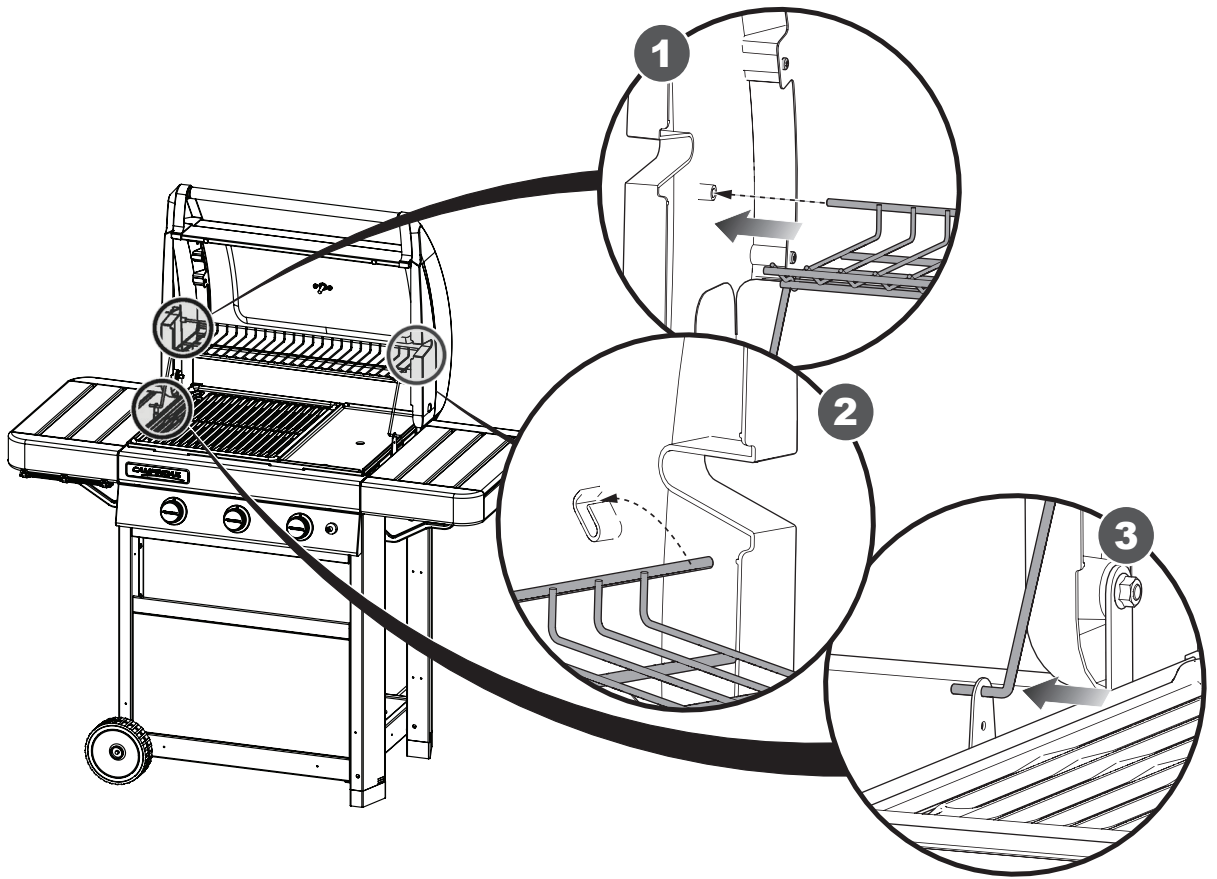



- FR** - Quelque soit la hauteur H et le diamètre ou la largeur maximum D de la bouteille, ne pas placer la bouteille de gaz sous le barbecue.
- GB** - Whatever the height H and diameter D or the maximum width of the gas cylinder, do not put the gas cylinder under the barbecue.
- DE** - Gasflasche nicht unter den Grill stellen, ohne Rücksicht auf die Höhe H und den Durchmesser oder die maximale Breite D der Flasche.
- IT** - Non sistemare la bombola del gas sotto il barbecue, indipendentemente dall'altezza H e dal diametro o dalla larghezza massimo/a D della bombola.
- ES** - Sea cual sea la altura H y el diámetro o la anchura máxima D de la botella, no coloque la botella de gas debajo de la barbacoa.
- PT** - Qualquer que seja a altura H e o diâmetro ou a largura máxima D da garrafa, não colocar a garrafa de gás sob o grelhador.
- NL** - Wat de hoogte H en de diameter of de breedte D van de fles ook mag zijn, u dient de gasfles niet onder de barbecue te plaatsen.
- SE** - Oavsett höjden H och diametern, eller behållarens maximala bredd D, placera inte gasbehållaren under grillen.
- NO** - Uavhengig av høyden H og diameteren eller maksimumsbredden D på flasken, må du ikke plassere gassflasken under grillen.
- DK** - Placér aldrig gasflasken under grillen, lige meget om flasken er indenfor højden H og har maksimum diameter eller bredde D.
- FI** - Älä aseta kaasupulloa grillin alle, olipa sen korkeus H ja halkaisija tai suurin leveys D mikä tahansa.
- CZ** - A je výška H, maximální průměr a šířka D lahve jakákoliv, nepokládejte plynovou lahev pod barbecue.
- HU** - Bármekkora is legyen a palack „H” magassága vagy „D” maximális átmérője, soha ne helyezze a palackot a grillkészülék alá.
- HR** - Bez obzira koje je boca visine H i promjera ili širine D, ne stavljajte plinsku bocu na roštilj.
- SI** - Plinske jeklenke ne nameščajte pod žar, ne glede na njeno višino (H), premer ali maksimalno širino (D).
- SK** - Nezávisle od výšky H a amximálneho priemeru alebo šírky D fľaše neumiestňujte plynovú fľašu pod gril.
- PL** - Niezależnie od wysokości (H) i maksymalnej średnicy lub szerokości (D) butli nie wolno umieszczać butli gazowej pod grillen.
- GR** - Μην τοποθετείτε τη φιάλη υγραερίου κάτω από το μπάρμπεκιου, ανεξαρτήτως του ύψους H και της διαμέτρου ή του μέγιστου πλάτους D της φιάλης.
- RO** - Oricare ar fi înălțimea H și diametrul sau lățimea maximă D a buteliei, nu așezați butelia cu gaz sub grătar.
- BG** - Каквито и да са стойностите на височината H и на диаметъра или максималната ширина D на бутилката, не поставяйте газовата бутилка под барбекюто.
- TR** - Yüksekliği (H) ve azamî genişliği (D) ne olursa olsun, gaz tüpünün ızgaranın altına yerleştirilmemesi gerekir.

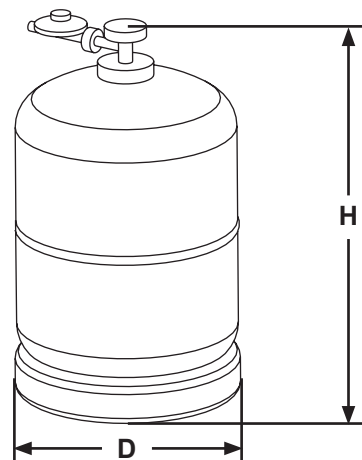

H < 70 cm

