

# CALANQUES

APP.E27.D30.MET&ROT.CALANQUES

CODE COREP : 656759

EAN 13 :



Rue Radio-Londres  
CS50001 - 33323 BÈGLES CEDEX (FRANCE)  
France : contactpro@corep.com  
Export : export@corep.com  
www.corep.com

Coloris : naturel

E27 - 60W

Color : natural

Description : Applique réflecteur forme dôme en rotin tressé à la main et base en métal peint.

Wall light, hand-woven rattan dome reflector and painted metal base.

AMPOULE  
CONSEILLÉE



G80  
654322  
10507

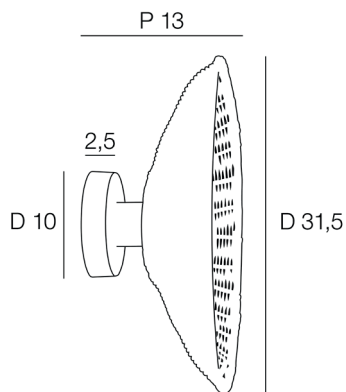

POIDS NET/NET WEIGHT : 360 gr

COLIS 1 COLOR\_BOX

L32xP11xH32 cm

POIDS BRUT/GROSS WEIGHT : 470 gr

