

mecafer



150120M

150121M

150123M

150129M

151192M

161123M

170121M

171120M

171123M

176122M

- I** Manuale istruzioni
- F** Manuel utilisateur
- D** Betriebsanleitung
- GB** Instructions for use manual
- E** Manual de instrucciones
- PL** Instrukcje obsługi
- P** Manual de instruções
- NL** Gebruiksaanwijzing
- DK** Brugsanvisning
- S** Instruktionsmanual
- FIN** Käyttöohjeet
- GR** Εγχειρίδιο οδηγιών
- HR** Uputstvo za uporabu
- SLO** Priročnik z navodili
- H** Kezelési útmutató
- CZ** Příručka k obsluze
- SK** Návod na obsluhu
- RUS** Руководство по эксплуатации
- N** Bruksanvisning
- TR** Kullanma talimatı
- RO** Manual de utilizare
- BG** Ръководство по експлоатацията
- SRB** Uputstvo za upotrebu
- LT** Vartotojo vadovas
- EST** Kasutaja käsiraamat
- LV** Lietotāja rokasgrāmata
- IS** Notendahandbók



150129M

150131M







150132M

160132M





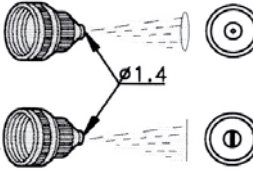

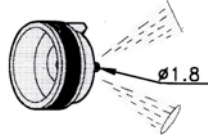
170132M

176121M

- I** Aerografo serbatoio inferiore
- F** Pistolet de peinture suction
- D** Farbspritzpistole mit Saugbecher
- GB** Suction air spray gun
- E** Aerografo deposito inferior
- P** Pistola Pintar Copo Inferior
- NL** Verfspruitpistool met aanzuigbeker
- DK** Malepistol med underliggende beholder
- S** Luft färgspruta med sugbägare
- FIN** Maaliruisku alapuolisella säiliöllä
- GR** Πιστόλι βαφής
- PL** Pistolet natryskowy z dolnym zbiornikiem
- HR** Lakirni pištolj s posodom ispred
- SLO** Lakirna pištola s posodo spodaj
- H** Festékszóró, alsó tartályos
- CZ** Strikací pistole se zásobníkem dolu
- SK** Striekacia pistol so zásobníkom dole
- RUS** Краскораспылитель с нижним бачком
- N** Sprøytepestol med underliggende beholder.
- TR** Alttan depolu boya tabancası
- RO** Pistol de vopsit cu rezervor inf
- BG** Бояджийски пистолет с долно казанче
- SCG** Aerograf s donjim rezervoarom
- LT** Dažymo pistoletas su bakeliu apačioje
- EST** Värvipüstol alamahutiga
- LV** Krāsošanas pistole
- IS** Sogkrafts loftbyssa

					
A		200 L/mn 7,1 cfm	1 Lt	3 bar 43,5 psi	
C		300 L/mn 10,6 cfm	1 Lt	3,5 bar 50,75 psi	

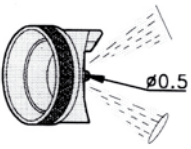
- I** Aerografo serbatoio superiore
- F** Pistolet de peinture gravité
- D** Farbspritzpistole mit Fließbecher
- GB** Gravity air spray gun
- E** aerografo deposito superior
- P** Pistola Pintar Copo Superior
- NL** Verf spuitpistool met mengbeker
- DK** Malepistol med overliggende beholder
- S** Luft Färgspruta med ovanliggande bägare
- FIN** Maaliruisku yläpuolisella säiliöllä
- GR** Πιστόλι βαφής "άνω" δοχείο
- PL** Pistolet natryskowy z górnym zbiornikiem
- HR** Lakirni pištolj s gravitacijskom posodom
- SLO** Lakirna pištola z gravitacijsko posodo
- H** Festékszóró, felsőtartályos
- CZ** Strikací pistole se zásobníkem nahoru
- SK** Striekacia pistol so zasobníkom hore
- RUS** Краскораспылитель с верхним бачком
- N** Sprøytepistol med overliggende beholder.
- TR** Üstten depolu boya tabancası
- RO** Pistol de vopsit cu rezervor sup
- BG** Бояджийски пистолет с горно казанче
- SCG** Aerograf s gornjim rezervoarom
- LT** Dažymo pistoletas su bakeliu viršuje
- EST** Värvipüstol ülamahutiga
- LV** Krāsošanas pistole
- IS** Loftbyssa með þyngdarverkun

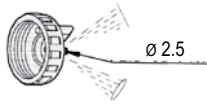
					
D		60 L/mn 2,1 cfm	0,25 Lt	3 bar 43,5 psi	
E		250 l/mn 8,8 cfm	0,5 Lt	3 bar 43,5 psi	

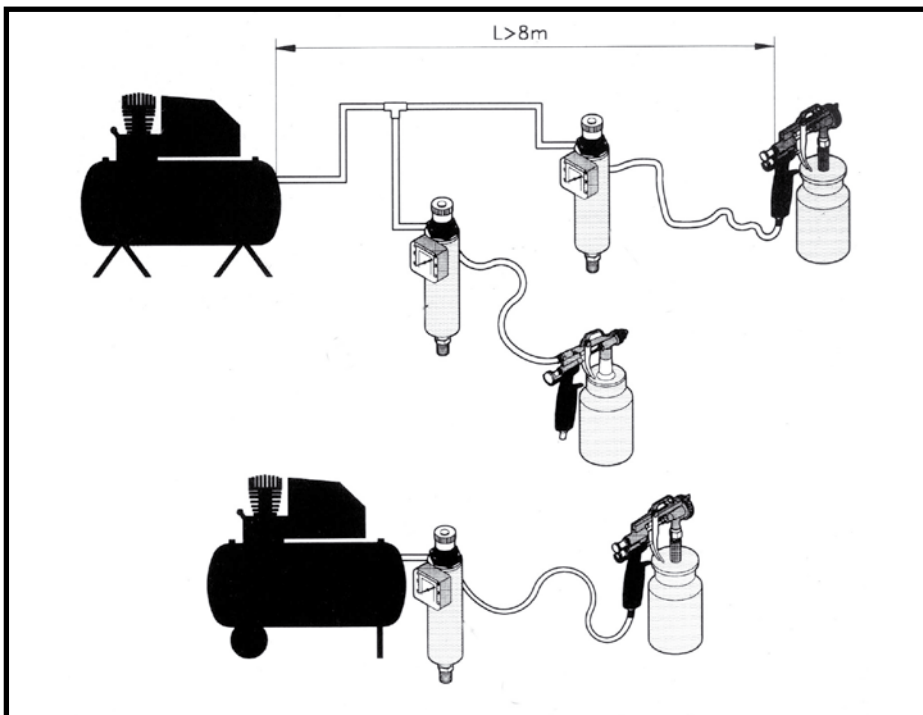
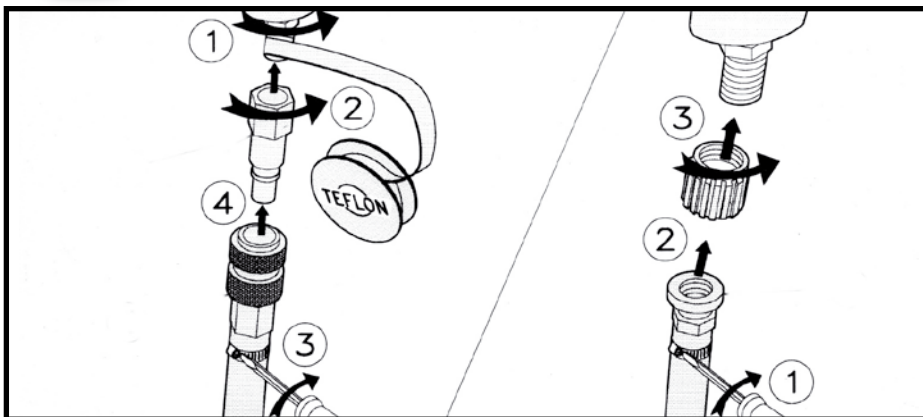

UTILIZZO - USE - UTILISATION - GEBRAUCH
 USO - UTILIZAÇÃO - GEBRUIK - BRUG
 ANVÄNDNING - KÄYTTÖ - ΧΡΗΣΗ - UŻYTKOWANIE
 KORIŠTENJE - UPORABA - ALKALMAZÁS
 ΡΟΥΖΙΤΉ - ROUŽÍVANIE
 ΚΑΚ ΡΑΒΟΤΑΤΉ Σ ΠΝΕΒΜΟΗΝΣΤΡΥΜΕΝΤΟΜ
 BRUK - KULLANIM - UTILIZARE - УПОТРЕБА
 KORIŠĆENJE - NAUDOJIMAS - LIETOŠANA
 KASUTAMINE - NOTKUN

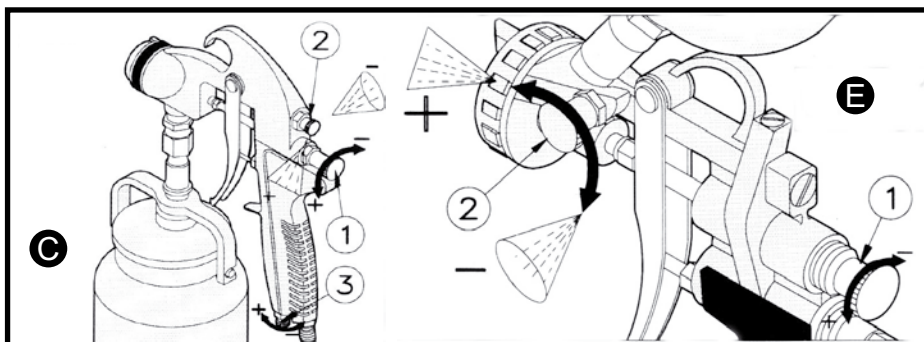
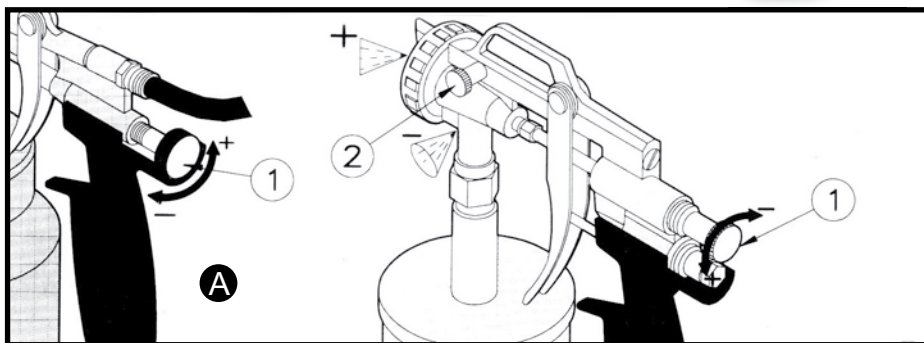

①

portata pittura - flow of paint
 debit peinture - Lacklieferungsmenge
 flujo de pintura - quantidade de pintura
 afgegeven hoeveelhed
 malingens gennemstrømning
 färgflöde - maalivirtaus
 παροχή βαφής - przepływ farby
 protok boje - pretok barve
 festékszálítás - průtok barvy
 prietok farby - расход краски
 malingsflyt - boya akiciliği
 suprafață acoperită - капацитет на боя
 protok boje - purškimo našumas
 vārvikulu - krāsas patēriņš
 skuldfærsla

②

forma getto - form of spary
 forme jet - Spritzform
 forma chorro - forma jato
 straalvorm
 spray-form
 strålens form - suihkun muoto
 μορφή εκτόξευσης - forma: rozprysk
 oblik mlaza - oblika pršenja
 sugar alakja - forma: sprej
 forma: sprej - форма распылителя
 sprayform - pūskūrtme šekli
 forma jetului - форма на струята
 oblik mlaza - purškimo forma
 dūūsi kuju - strūklas forma
 ásigkomulag

③

pressione aria - air pressure
 pression air - Luftdruck
 presión de aire - pressão ar
 luchtdruk
 lufttryk
 lufttryck - ilman paine
 πίεση αέρα - ciśnienie powietrza
 tlak zraka - zračni pritisk
 levegőnyomás - tlak vzduchu
 tlak vzduchu - давление воздуха
 trykkluft - hava basıncı
 presiunea aerului - въздушно налягане
 vazdušni pritisak - oro slėgis
 õhusurve - gaisa spiediens
 álag



UTILIZZO - USE - UTILISATION - GEBRAUCH
 USO - UTILIZAÇÃO - GEBRUIK - BRUG
 ANVÄNDNING - KÄYTTÖ - ΧΡΗΣΗ - UŻYTKOWANIE
 KORIŠTENJE - UPORABA - ALKALMAZÁS
 ROUŽITÍ - ROUŽÍVANIE
 КАК РАБОТАТЬ С ПНЕВМОИНСТРУМЕНТОМ
 BRUK - KULLANIM - UTILIZARE - УПОТРЕБА
 KORIŠČENJE - NAUDOJIMAS - LIETOŠANA
 KASUTAMINE - NOTKUN

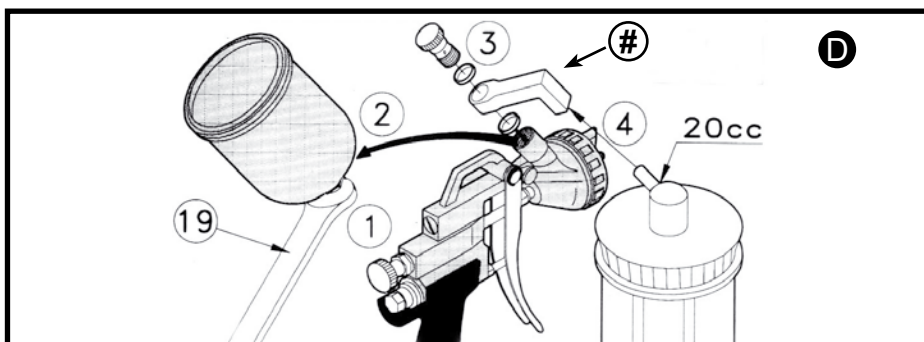
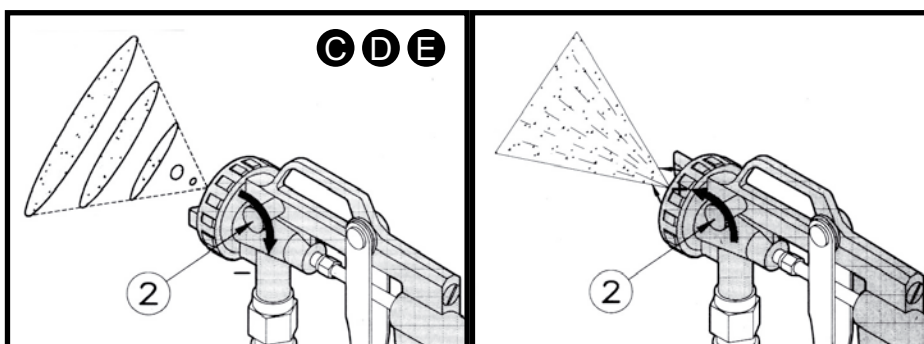

②

forma getto - form of spary
 forme jet - Spritzform
 forma chorro - forma jato
 straalvorm
 spray-form
 strålens form - suihkun muoto
 μορφή εκτόξευσης - forma: rozprysk
 oblik mlaza - oblika pršenja
 sugar alakja - forma: sprej
 forma: sprej - форма распылителя
 sprayform - puskürtme şekli
 forma jetului - форма на струята
 oblik mlaza - purškimo forma
 düüsi kuju - strūklas forma
 äsigkomulag

#

adattore recipienti 20cc
 adaptater for 20cc bowls
 adaptateur récipients 20cc
 Adapter für 20 ccm-Behälter
 adaptador de recipiente 20cc
 adaptador recipientes 20cc
 aanpassingsstuk voor potten van 20cc
 adaptor til 20cc beholdere
 adapter för 20cc kärl
 sovituskappale 20cc astioita varten
 προσαρμοστήρας για δοχεία 20cc
 adapter dla zbiorników 20 cm³
 adapter za spremnike od 20cm³

adapter za 20cc posode
 20cc tartály adapter
 adaptér pro nádrže 20 cm³
 adaptér pre nádrže 20 cm³
 насадка для емкостей 20cc
 adapter for 20cc beholdere
 20 cc'lik kap için adaptör
 adaptor recipiente 20 cm³
 адаптер на съдове 20 куб.см
 adapter za posude od 20 cm³
 adapteris 20 cm³ indams
 20 cm³ nõu hoidik
 adapters 20 cm³ tvertnēm
 millistykki 20cc

UTILIZZO - USE - UTILISATION - GEBRAUCH
USO - UTILIZAÇÃO - GEBRUIK - BRUG
ANVÄNDNING - KÄYTTÖ - ΧΡΗΣΗ - UŻYTKOWANIE
KORIŠTENJE - UPORABA - ALKALMAZÁS
POUŽITÍ - ROUŽÍVANIE
ΚΑΚ ΡΑΒΟΤΑΤΉ Σ ΠΝΕΒΜΟΙΝΣΤΡΥΜΕΝΤΟΜ
BRUK - KULLANIM - UTILIZARE - УПОТРЕБА
KORIŠĆENJE - NAUDOJIMAS - LIETOŠANA
KASUTAMINE - NOTKUN

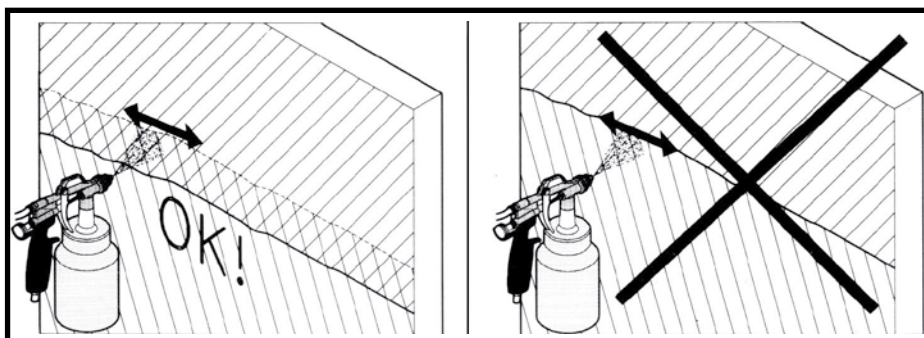
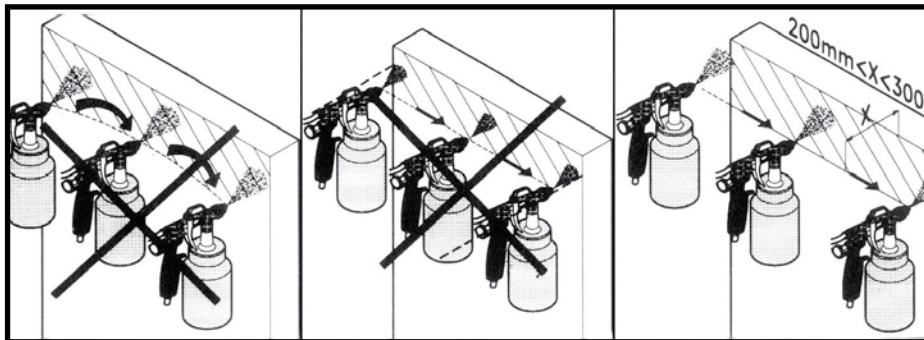
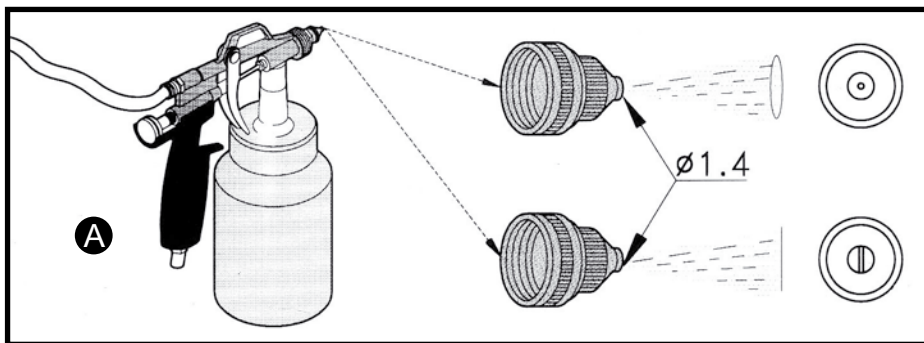



UTILIZZO - USE - UTILISATION - GEBRAUCH
 USO - UTILIZAÇÃO - GEBRUIK - BRUG
 ANVÄNDNING - KÄYTTÖ - ΧΡΗΣΗ - UŻYTKOWANIE
 KORIŠTENJE - UPORABA - ALKALMAZÁS
 ROUŽITÍ - ROUŽIVANIE
 КАК РАБОТАТЬ С ПНЕВМОИНСТРУМЕНТОМ
 BRUK - KULLANIM - UTILIZARE - УПОТРЕБА
 KORIŠČENJE - NAUDOJIMAS - LIETOŠANA
 KASUTAMINE - NOTKUN

A C

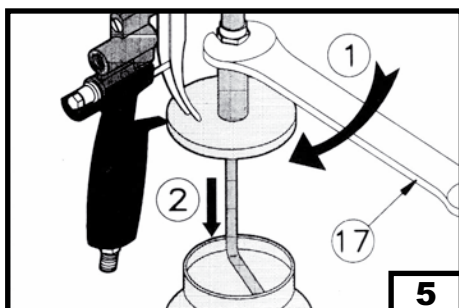
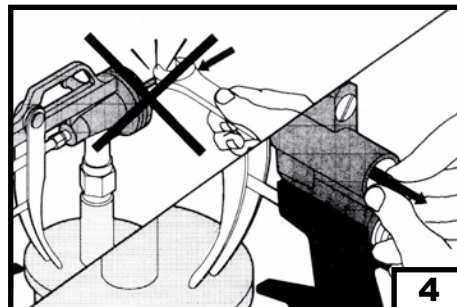
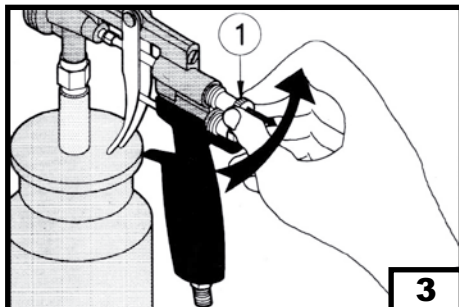
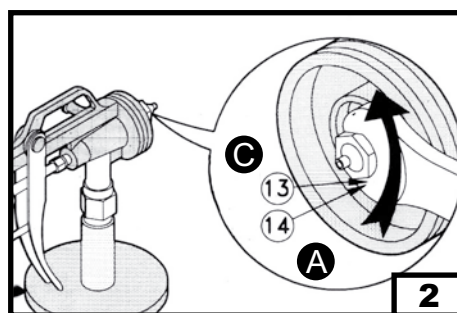
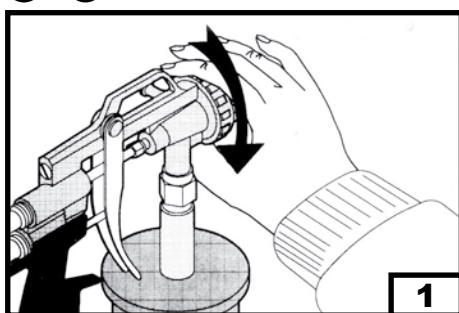

solvente pittura - paint solvent
 Solvant peinture - Lacklösmittel
 disolvente de pintura - dissolvente pintura
 verfvodunner - opløsningsmiddel til maling
 färglösningsmedel - maalin liuotin
 διαλυτικό βαφής - rozpuszczalnik farby
 otapalo za boju - barvno topilo
 festék oldószer - rozpuštědlo barvy
 rozpušťač farby - растворитель для краски
 malingsløsemiddel - boya solventi
 solvent vopsea - разтворител боя
 rastvarač za boju - tirpiklis dažams
 värvilahusti - krāsu šķīdinātājs
 leysiefni

UTILIZZO - USE - UTILISATION - GEBRAUCH
 USO - UTILIZAÇÃO - GEBRUIK - BRUG
 ANVÄNDNING - KÄYTTÖ - ΧΡΗΣΗ - UŻYTKOWANIE
 KORIŠTENJE - UPORABA - ALKALMAZÁS
 ROUŽITÍ - ROUŽIVANIE
 ΚΑΚ ΡΑΒΟΤΑΤΉ Σ ΠΝΕΒΜΟΙΝΣΤΡΥΜΕΝΤΟΜ
 BRUK - KULLANIM - UTILIZARE - УПОТРЕБА
 KORIŠĆENJE - NAUDOJIMAS - LIETOŠANA
 KASUTAMINE - NOTKUN

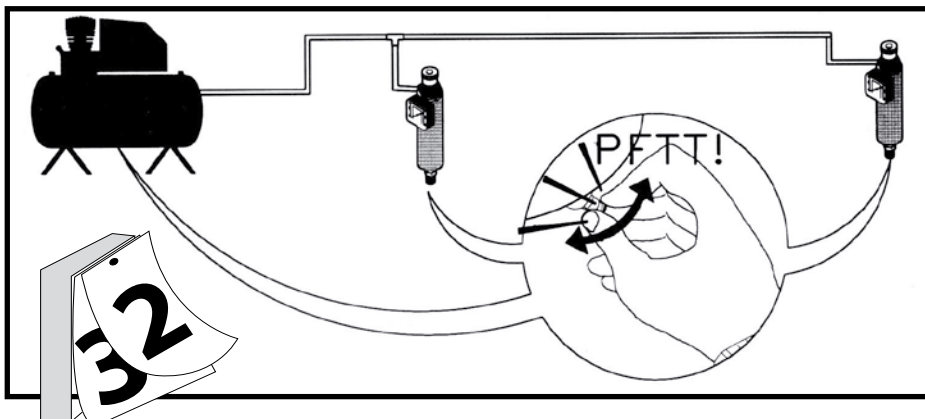
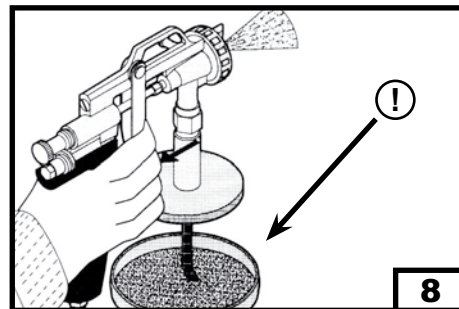
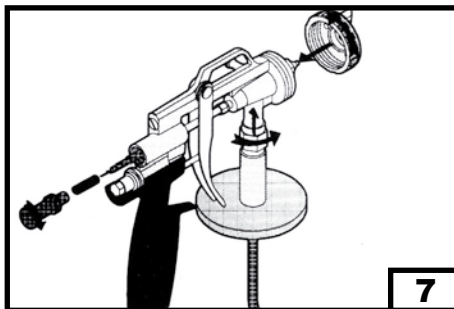
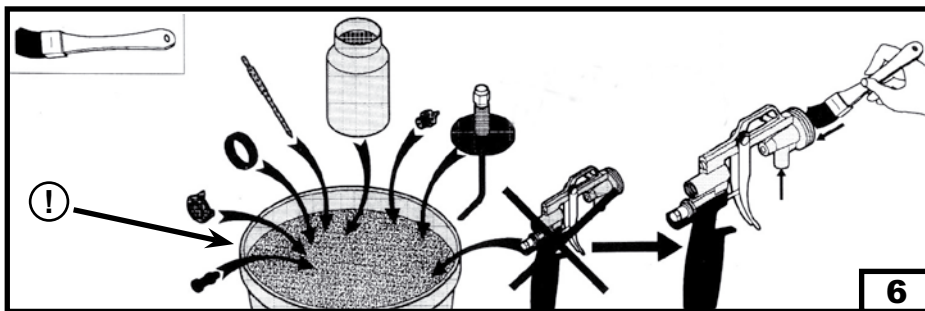



UTILIZZO - USE - UTILISATION - GEBRAUCH
 USO - UTILIZAÇÃO - GEBRUIK - BRUG
 ANVÄNDNING - KÄYTTÖ - ΧΡΗΣΗ - UŻYTKOWANIE
 KORIŠTENJE - UPORABA - ALKALMAZÁS
 ΡΟΥΖΙΤΙ - ΡΟΥΖΙΒΑΝΙΕ
 КАК РАБОТАТЬ С ПНЕВМОИНСТРУМЕНТОМ
 BRUK - KULLANIM - UTILIZARE - УПОТРЕБА
 KORIŠČENJE - NAUDOJIMAS - LIETOŠANA
 KASUTAMINE - NOTKUN

D E

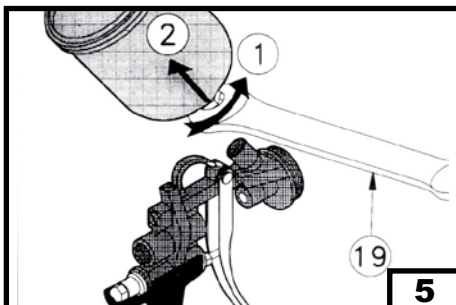
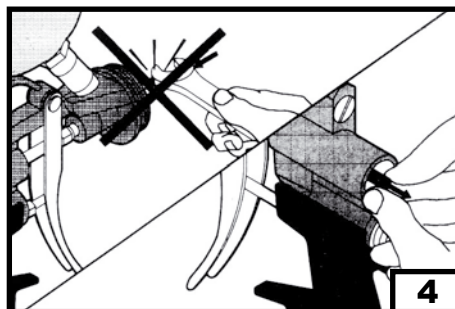
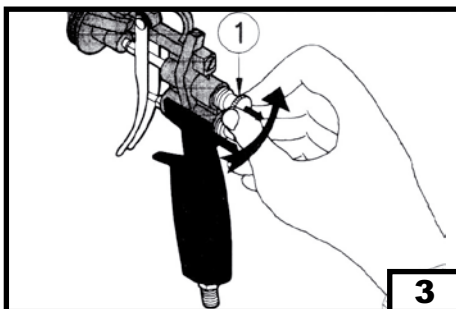
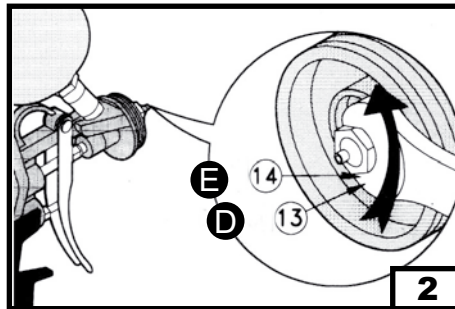
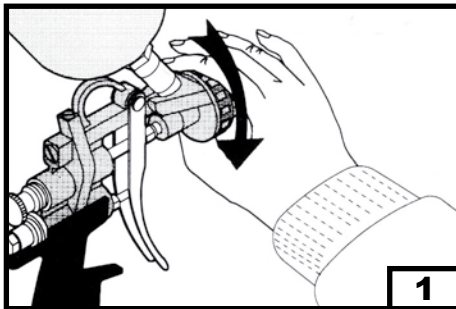

solvente pittura - paint solvent
 Solvant peinture - Lacklösmittel
 disolvente de pintura - dissolvente pintura
 verfvæddner - opløsningsmiddel til maling
 färglösningsmedel - maalin liuotin
 διαλυτικό βαφής - rozpuszczalnik farby
 otapalo za boju - barvno topilo
 festék oldószer - rozpuštedlo barvy
 rozpuštdadlo farby - rastvoritel' dlya kraski
 malingsløsemiddel - boya solventi
 solvent vopsea - rastvoritel' boya
 rastvarač za boju - tirpiklis dažams
 värvilahusti - kräsu šķīdinātājs
 leysiefni

UTILIZZO - USE - UTILISATION - GEBRAUCH
USO - UTILIZAÇÃO - GEBRUIK - BRUG
ANVÄNDNING - KÄYTTÖ - ΧΡΗΣΗ - UŻYTKOWANIE
KORIŠTENJE - UPORABA - ALKALMAZÁS
POUŽITÍ - ROUŽÍVANIE
КАК РАБОТАТЬ С ПНЕВМОИНСТРУМЕНТОМ
BRUK - KULLANIM - UTILIZARE - УПОТРЕБА
KORIŠČENJE - NAUDOJIMAS - LIETOŠANA
KASUTAMINE - NOTKUN

