

kordo.

une marque du groupe
BURGER

A

PANNEAU ANTICHUTE

protection panel
REF. 3441

TRANSPARENT
ANTI-UV

ALU
RAL7016

- **1 panneau synthétique**
transparent traité UV dimensions 4x640x940mm
EN 1 UV treated transparent synthetic glass panel size
4x640x940mm

- **4 supports de vitre et vis inox A2**
EN 4 glass holders and A2 stainless steel screws

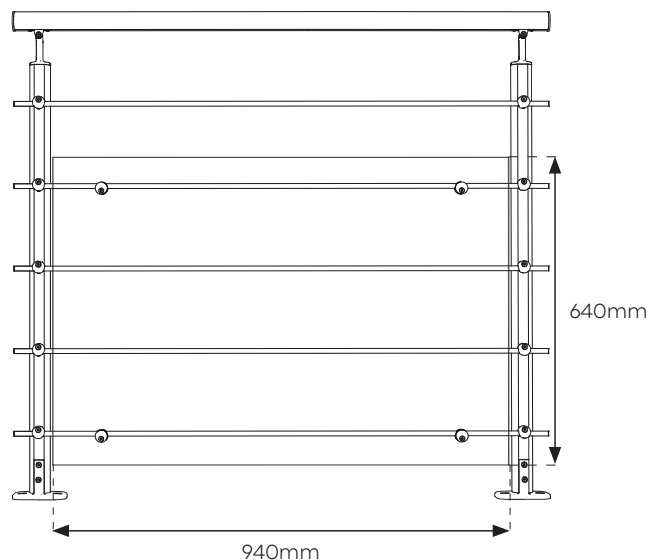

Conforme aux normes **NF P01-012** et **NF P01-013** s'appliquant pour une hauteur de chute supérieure à 1 mètre.

EN Conform to **NF P01-012** and **NF P01-013** standards for installation height over 1 meter.

GUIDE DE MONTAGE

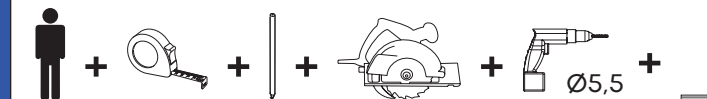

| | | | | |
|-------------------|-------|--|------------|----|
| Support verre A | 70515 | | Ø25,3x13mm | x4 |
| Caoutchouc | 72780 | | Ø25x1,5mm | x8 |
| Support verre B | 70516 | | Ø25,1x5mm | x4 |
| Vis | 72888 | | M5x20 | x4 |
| Verre synthétique | 70905 | | 940x640mm | x1 |

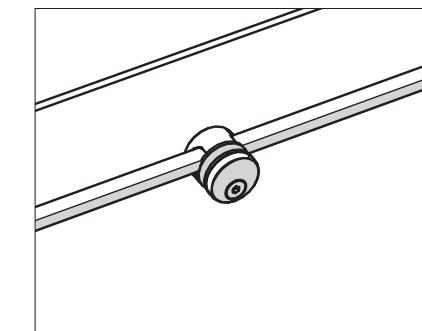
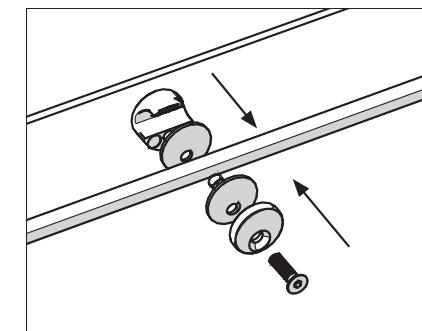
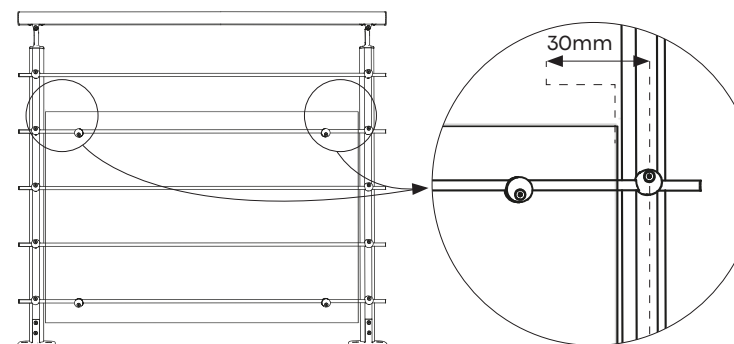
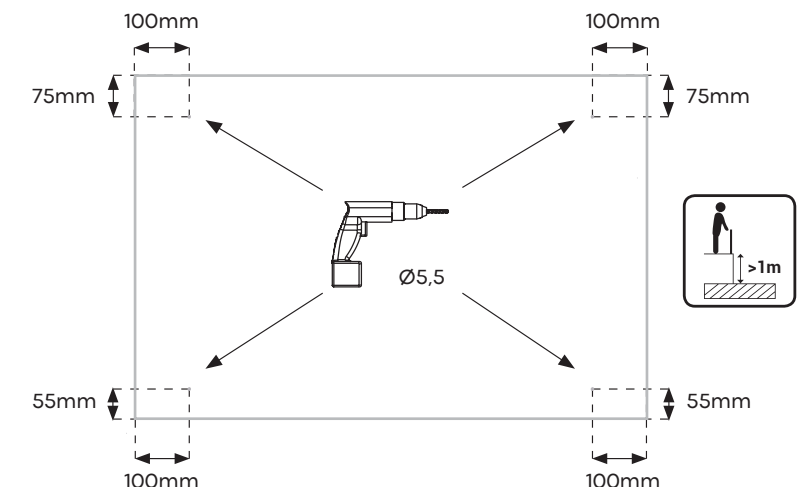

www.kordodesign.com

La durée et les conditions de garanties peuvent être consultées sur :
<https://kordodesign.com/garanties-garde-corps/>.

Fabricant : Kordo – Burger & Cie, ZI Bois l'Abbesse 68660 LIEPVRE- France
Contact : serviceclient@kordodesign.com

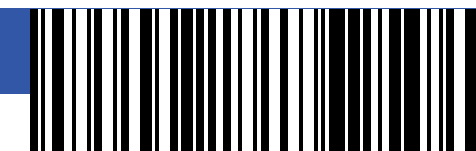
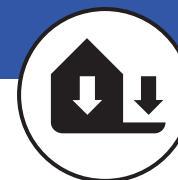

3443440034414



Eléments
d'emballage



TRIEZ
RÉEMPLOYEZ
RECYCLEZ

ASSOCIATION OU DÉCHÈTERIE
DISTRIBUTEUR

Adresses sur quefairedemesdechets.fr