

blooma 

Zéphyr

3454976031754

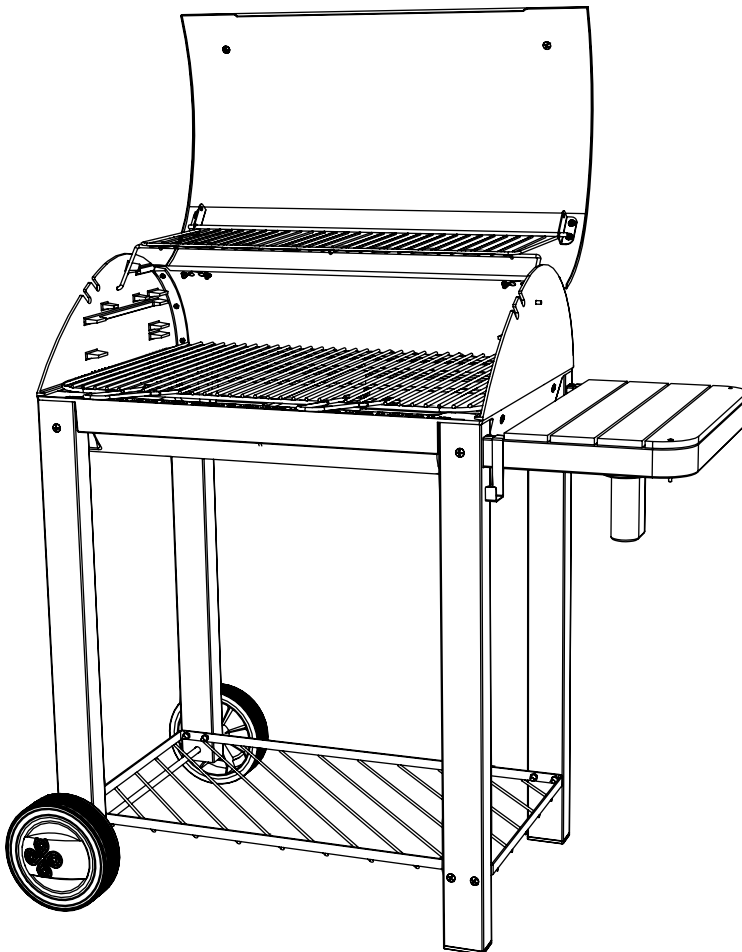

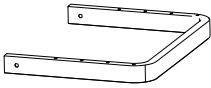

[1] x 1

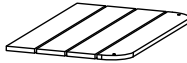

[2] x 1



[3] x 2



[4] x 1



[5] x 2

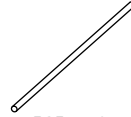

[6] x 1



[7] x 2



[8] x 2



[9] x 1

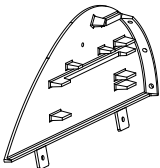

[10] x 1

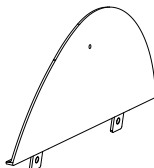

[11] x 1

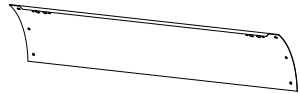

[12] x 1

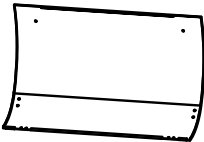

[13] x 1



[14] x 2



[15] x 1

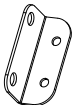

[16] x 2



[17] x 1



[18] x 1



[19] x 1



[20] x 1

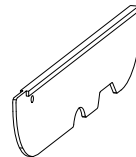

[21] x 1

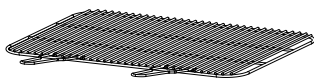

[22] x 1



[23] x 1

1 : 1

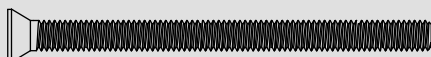

[27] x 2 (M4 x 55)

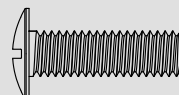

[28] x 11 (M6 x 20)

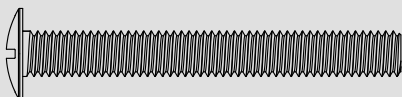

[29] x 8 (M6 x 50)



[30] x 18 (Ø6)

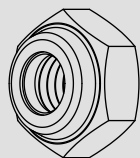

[31] x 2 (Ø10)

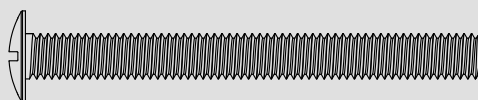

[32] x 4 (M6 x 60)

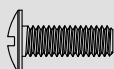

[33] x 18 (M4 x 12)



[34] x 20 (Ø4)

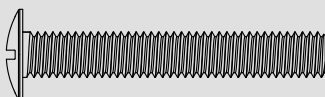

[36] x 1 (M6 x 40)



[35] x 12 (Ø4)



APPAREILS MÉNAGERS
UTILISANT DES COMBUSTIBLES
LIQUIDES OU SOLIDES
www.marque-nf.com
TOM 355016



DOMESTIC APPLIANCES
USING LIQUID OR SOLID FUELS
www.marque-nf.com

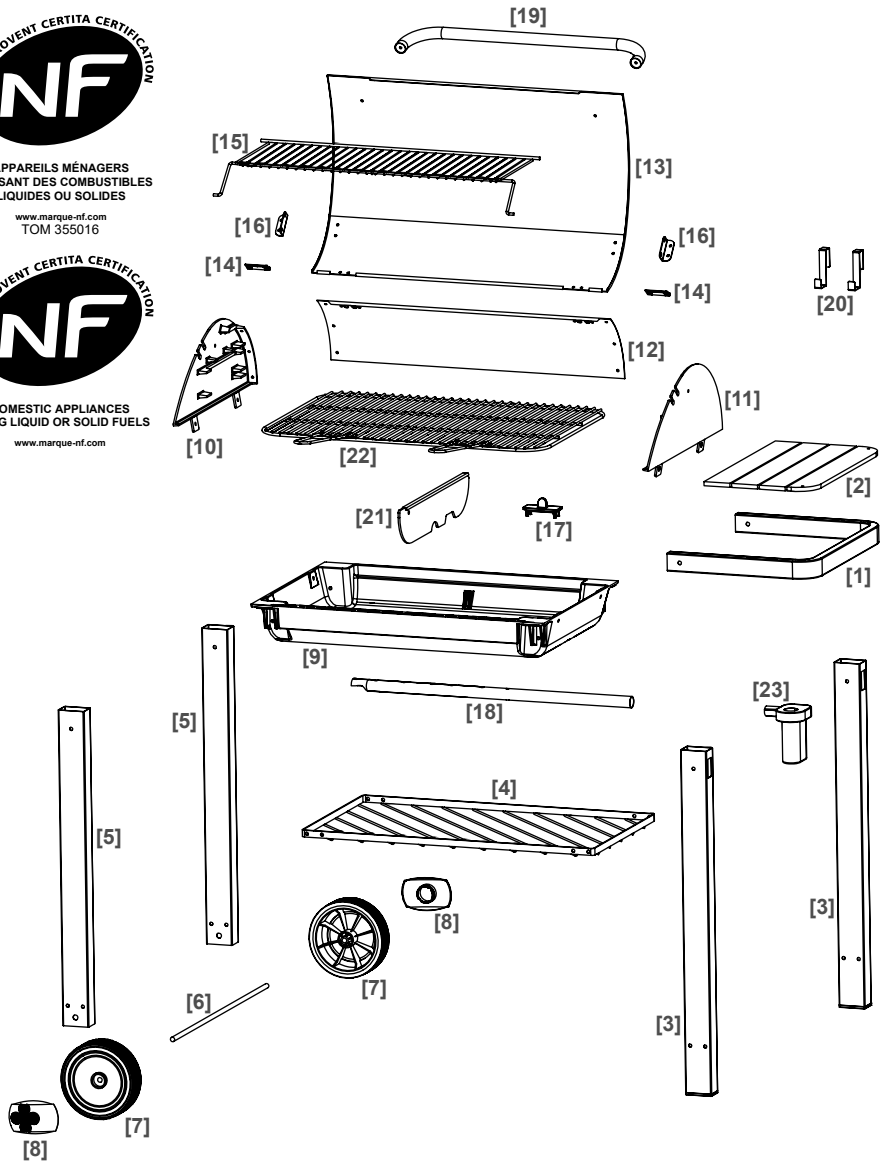

Ces instructions sont pour votre sécurité. Lisez-les attentivement avant utilisation et conservez-les pour une consultation ultérieure.

C'est parti...



Pour bien commencer

07

Avant de commencer

08

Sécurité

08



Et dans le détail...

09

Informations **techniques** et **légales**

10

Entretien et **maintenance**

11

Garantie

11

Assemblage

44



Quelle que soit votre hâte de profiter pleinement de votre barbecue, nous vous recommandons de lire attentivement cette notice. Son contenu vous fournira des indications importantes concernant la sécurité d'installation, d'utilisation et d'entretien.



Pour bien commencer...

Avant de commencer 08

Sécurité 08

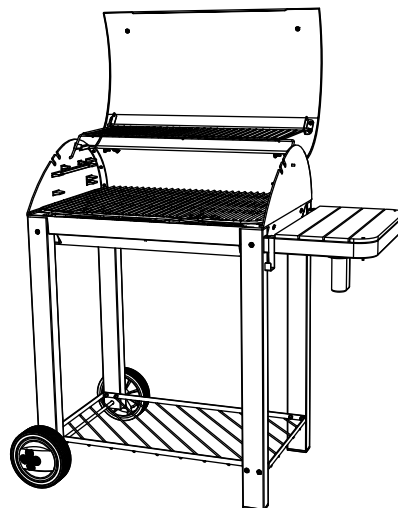

A vérifier



Vérifier le contenu, les pièces et la visserie présentés dans le tableau p. 2 - 3 et les clés dont vous aurez besoin.

Votre Produit

1. Le piétement
2. La cuve
3. La grille chauffe plat
4. La soufflerie
5. Couvercle de protection

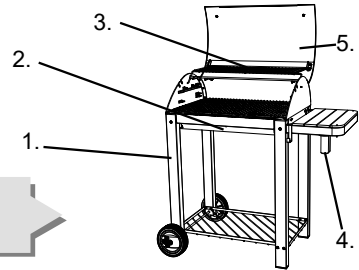

Pour installer votre produit, rendez-vous sur la séquence de montage située à la fin du guide.

Vous aurez besoin de

(éléments non fournis)

Clé plate de 7



Clé plate de 10



Clé plate de 13



Sécurité

Vérifiez que vous avez intégré toutes les consignes ci-dessous

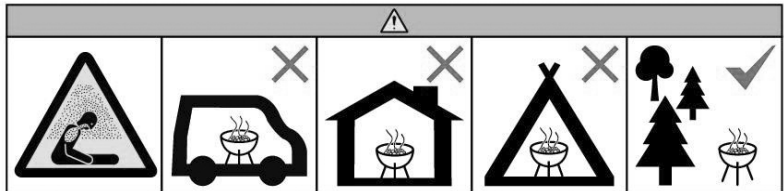

- Ne pas utiliser le barbecue dans un espace confiné et/ou habitable par exemple des maisons, tentes, caravanes, camping-cars, bateaux. Risque de décès par empoisonnement au monoxyde de carbone.
- ATTENTION : UTILISATION A L'EXTERIEUR UNIQUEMENT**, les barbecues ne doivent pas être utilisés à l'intérieur des espaces fermés ou sous une tonnelle, ni dans toutes structures extérieures similaires en raison du dégagement de MONOXYDE DE CARBONE et des RISQUES D'INCENDIES.
- Par journée à vent fort, placer votre barbecue de telle manière que le vent ne soulève pas d'étincelles.
- Ne pas asperger une cuve avec de l'eau froide afin d'éviter un choc thermique.
- Le barbecue doit être installé sur un support horizontal stable avant utilisation.
- Ce barbecue doit être chauffé et le combustible doit être maintenu incandescent pendant au moins 30 minutes avant d'effectuer la première cuisson.



Et dans le détail...

Informations techniques et légales	10
Entretien et maintenance	11
Garantie	11

Et dans le détail...

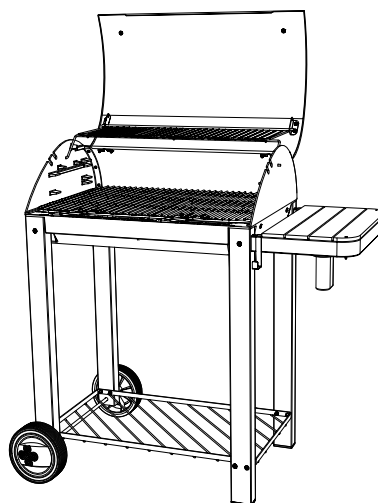

Caractéristiques techniques

Fabriqué en France

Référence fournisseur: TOM 355016

Marque commerciale: Blooma

Avertissements

Ce barbecue est conforme à la norme EN 1860-1

Toutefois, son utilisation exige un minimum de surveillance et de précautions.

Pour votre sécurité :

- > 1.ATTENTION ! – Ne pas utiliser dans les locaux fermés.
- > 2.ATTENTION ! – Ne pas utiliser d'alcool, d'essence ou tout autre liquide analogue pour allumer ou réactiver le barbecue.
- > 3.ATTENTION ! – Ne pas laisser le barbecue à la portée des enfants et des animaux domestiques. On déplore, en effet, chaque année, un grand nombre d'accidents. Les brûlures sont particulièrement graves chez les enfants, car du fait de leur petite taille, leur visage se trouve presque toujours à la hauteur du foyer.
- > 4.Par journée à vent fort, placer votre barbecue de telle manière que le vent ne soulève pas d'étincelles.
- > 5.Ne pas asperger une cuve avec de l'eau froide afin d'éviter un choc thermique.
- > 6.Le barbecue doit être installé sur un support horizontal stable avant utilisation.
- > 7.Ce barbecue doit être chauffé et le combustible doit être maintenu incandescent pendant au moins 30 minutes avant d'effectuer la première cuisson.
- > 8.ATTENTION ! – Ce barbecue va devenir très chaud. Ne pas le déplacer pendant son utilisation.

Quelques conseils :

- > 1.Avant d'introduire le charbon dans le foyer, garnissez-le d'une feuille d'aluminium.
Non seulement vous le protégez et il sera beaucoup plus facile à nettoyer, mais cette feuille servira également de réflecteur de chaleur.
- > 2.Ensuite, mettez votre charbon de bois. Utiliser du charbon de bois conforme à la norme NF EN 1860-2 de sorte que le charbon de bois soit 2 cm en dessous de la grille de cuisson en position basse.
- > 3. La méthode la plus aisée pour allumer votre charbon de bois est d'utiliser des allumes barbecues que vous trouverez facilement dans le commerce et qui sont absolument sans danger.
- > 4. Avant de commencer la cuisson, attendre qu'une couche de cendres recouvre le combustible.

remplacement de la pile



ENVIRONNEMENT : Si votre barbecue est équipé d'un moteur ou d'une soufflerie, ne pas jeter ni incinérer ces accessoires, conformez-vous aux règles de collecte, de récupération et de recyclage applicable à ces produits.

Information sur l'utilisation des piles: Les piles non rechargeables ne doivent pas être rechargées. Ne pas mélanger des piles ou accumulateurs n'étant pas du même type. Ne pas mélanger des piles ou accumulateurs neufs et usagés. Utiliser uniquement les piles ou accumulateurs du type recommandé ou d'un type similaire. Les piles ou accumulateurs doivent être mis en place en respectant le sens des polarités. Une mauvaise position peut endommager l'appareil. Les bornes d'une pile ou d'un accumulateur ne doivent pas être mises en court-circuit. Ne pas jeter les piles : veuillez les ramener au point de collecte le plus proche.

Garantie

Blooma garantit le barbecue contre les vices de fabrication ou défaut de matériau pendant :

- 10 ans pour la cuve en fonte de fabrication française.
- 2 ans pour les autres pièces détachées.

Cette garantie ne couvre pas les défauts liés à un mauvais montage, à une mauvaise utilisation ou un mauvais entretien.

Elle ne couvre pas non plus les dommages ou détériorations de pièces dus à un mauvais entretien ou si les conseils de la notice n'ont pas été respectés.

Cette garantie n'est plus valide si le produit a été modifié ou utilisé dans des conditions anormales.

Cette garantie ne couvre que les défauts mentionnés ci-dessus qui impactent directement l'utilisation du barbecue. Elle ne couvre pas les détériorations de la peinture ou de la finition.

Le magasin et le fournisseur ne sont pas responsables des dommages collatéraux (directs ou indirects) sur les biens ou les personnes.

Pour bénéficier de la garantie, l'acheteur doit informer le fabriquant du problème survenu et doit fournir :

- Une preuve d'achat (ticket de caisse, facture...)
- Des photos illustrant le problème
- La référence de la pièce concernée (indiquée en page 2 et 3 de votre notice)
- La référence à 13 chiffres du produit

Cette garantie se limite au remplacement de la pièce défectueuse qui vous sera envoyée sans frais.

Cette garantie se limite à un usage domestique du produit

En cas de problèmes, merci de contacter votre service après-vente. Merci de ne pas ramener le barbecue en magasin.



APPAREILS MÉNAGERS
UTILISANT DES COMBUSTIBLES
LIQUIDES OU SOLIDES

www.marque-nf.com
TOM 355016



DOMESTIC APPLIANCES
USING LIQUID OR SOLID FUELS

www.marque-nf.com

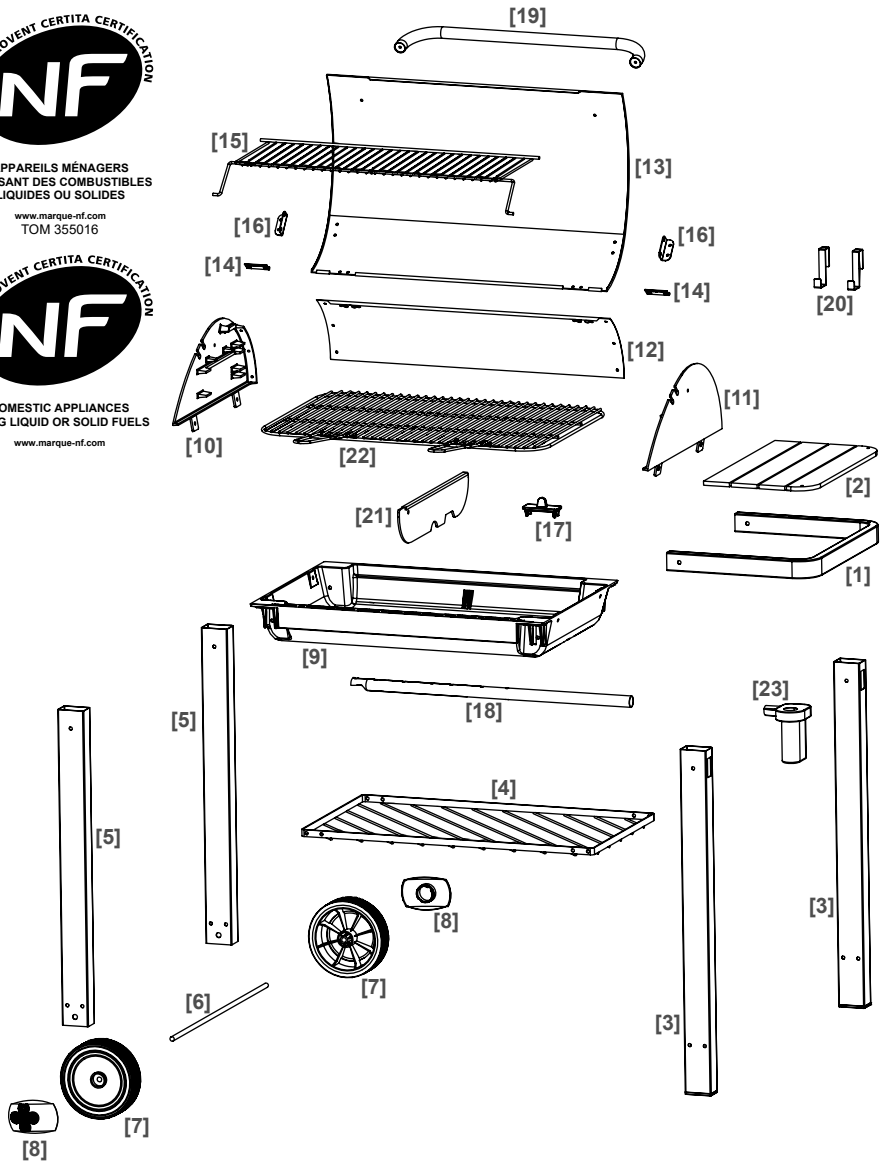

These instructions are for your safety. Read them carefully and keep them for future reference.

Let's go...



Let's get started

15

Before you begin
Safety

16

16



Further information...

17

Technical and legal information
Upkeep and maintenance
Warranty

18

19

19

Assembly

44



Even if you are in a hurry to get started with your barbecue, we recommend you read this notice carefully. It provides important information on set up safety, use and maintenance.



Let's get started...

Before you begin

16

Safety

16

Before you begin ...

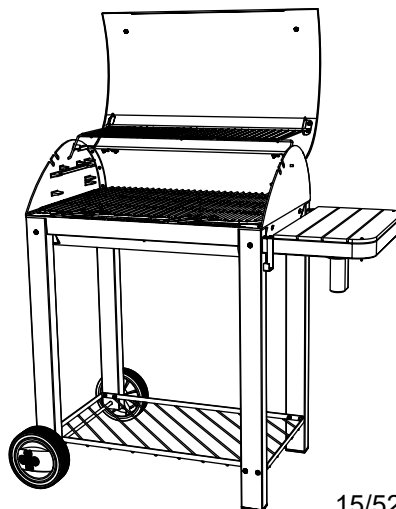

Check-list



Check the contents, parts and screws listed in the table on p. 2 - 3 and the tools you will need.

Your Product

1. Frame
2. Firebox
3. Flat warming grill
4. Blower
5. Protective hood

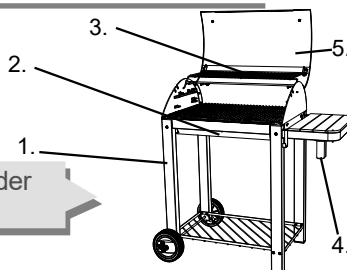

To set up your product, refer to the assembly order at the end of the guide.

You need

(parts not included)

7 spanner



10 spanner



13 spanner

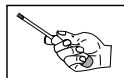

Safety

Check that you have followed all the advice below

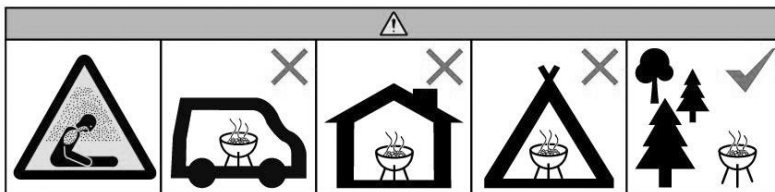

- Do not use the barbecue in a confined and/or habitable space e.g. houses, tents, caravans, motor homes, boats.
Danger of carbon monoxide poisoning fatality.
- WARNING: FOR OUTDOOR USE ONLY:** barbecues must not be used within an enclosed space or under a gazebo, or in any other similar outdoor structures due to the release of CARBON MONOXIDE and the RISK OF FIRE.
- On a windy day, turn your barbecue so that the wind can not cause sparks.
- To ensure safety, never sprinkle cold water near the cast iron hearth.
- The barbecue has to be installed on a secure level base prior to use.
- The barbecue shall be heated up and the fuel kept red for at least 30 minutes prior to the first cooking on the barbecue.



Further information...

Technical and legal information	18
Upkeep and maintenance	19
Warranty	19

Further information...

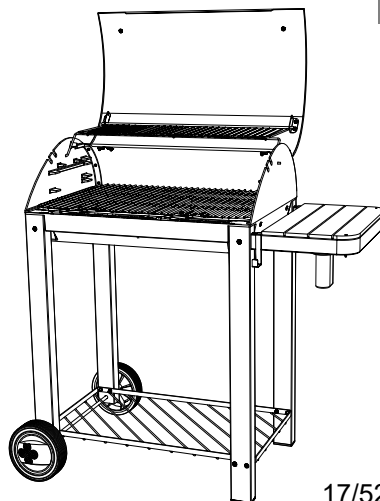

Technical specifications

Made in France

Supplier reference: TOM 355016

Trademark: Blooma

Warnings

This barbecue complies with standard EN 1860-1.
However, its use requires some monitoring and precautions.

For your safety:

- > 1. Do not use indoors!
- > 2. **WARNING!** Do not use spirit or petrol for lighting or relighting!
- > 3. **WARNING!** Keep children and pets away. Indeed, a large number of accidents are reported every year. Burns are particularly serious with young children, because, due to their height, their faces are nearly always on the same level as the fire.
- > 4. On a windy day, turn your barbecue so that the wind can not cause sparks.
- > 5. To ensure safety, never sprinkle cold water near the cast iron hearth.
- > 6. The barbecue has to be installed on a secure level base prior to use.
- > 7. The barbecue shall be heated up and the fuel kept red for at least 30 minutes prior to the first cooking on the barbecue.
- > 8. **WARNING!** This barbecue will become very hot, do not move it during operation.

Some tips:

- > 1. Before placing the charcoal in the burner, line with aluminium foil. Not only will you protect it, but it will be easier to clean and the foil will also act as a heat reflector.
- > 2. Then, add your charcoal. Use charcoal that complies with the current laws. The charcoal must be placed 2 cm under the grill when in its lowest position.
- > 3. The easiest method for lighting your charcoal is to use barbecue lighters that are easy to find in the shops.
- > 4. Before cooking, wait for a layer of ash to cover the charcoal.

Replacing the battery



ENVIRONMENT: If your barbecue is fitted with a motor or blower, do not dispose of or incinerate these accessories. Please comply with the collection and recycling regulations that apply to these products. Information on the use of batteries: Non-rechargeable batteries should not be recharged. Do not mix different types of batteries or accumulators. Do not mix new and used batteries or accumulators. Only use recommended or similar batteries or accumulators. Batteries and accumulators must be correctly fitted according to polarity. Incorrect fitting may damage the appliance. Battery or accumulator terminals must not be short-circuited. Do not dispose of batteries: please bring them to your nearest collection point.

Warranty

Blooma guarantees the barbecue against manufacturing defects or equipment defects for:

- 10 years for the French-manufactured cast iron firebox.
- 2 years for other separate parts.

This warranty does not cover defects caused by incorrect installation, incorrect use or poor maintenance.

It does not cover damage or deterioration of parts due to poor maintenance or if the instructions in the leaflet have not been followed. This warranty is not valid if the product has been modified or used under abnormal conditions.

This warranty only covers the above-mentioned defects that directly impact the use of the barbecue. It does not cover damage to the paint or finish.

The retailer and supplier are not responsible for collateral damage (direct or indirect) to property or people.

To claim with the warranty, the buyer must inform the manufacturer of any problem that arises and must supply:

- Proof of purchase (receipt, invoice, etc.)
- Photos illustrating the problem
- The reference of the relevant part (indicated on page 2 and 3 of your leaflet)
- The product reference has 13 digits This warranty is limited to the replacement of faulty parts, which you will be sent free of charge.

This warranty is limited to domestic use of the product. If you experience any problems, please contact your After-Sales Service.

Please do not return the barbecue to the retailer.

Manufacturer :

Kingfisher International Products Limited 3 Sheldon square, Paddington
LONDON W2 6PX

Fabrikant :

Kingfisher International Products B.V., Rapenburgerstraat 175E, 1011 VM
Amsterdam, The Netherlands



APPAREILS MÉNAGERS
UTILISANT DES COMBUSTIBLES
LIQUIDES OU SOLIDES

www.marque-nf.com
TOM 355016



DOMESTIC APPLIANCES
USING LIQUID OR SOLID FUELS

www.marque-nf.com

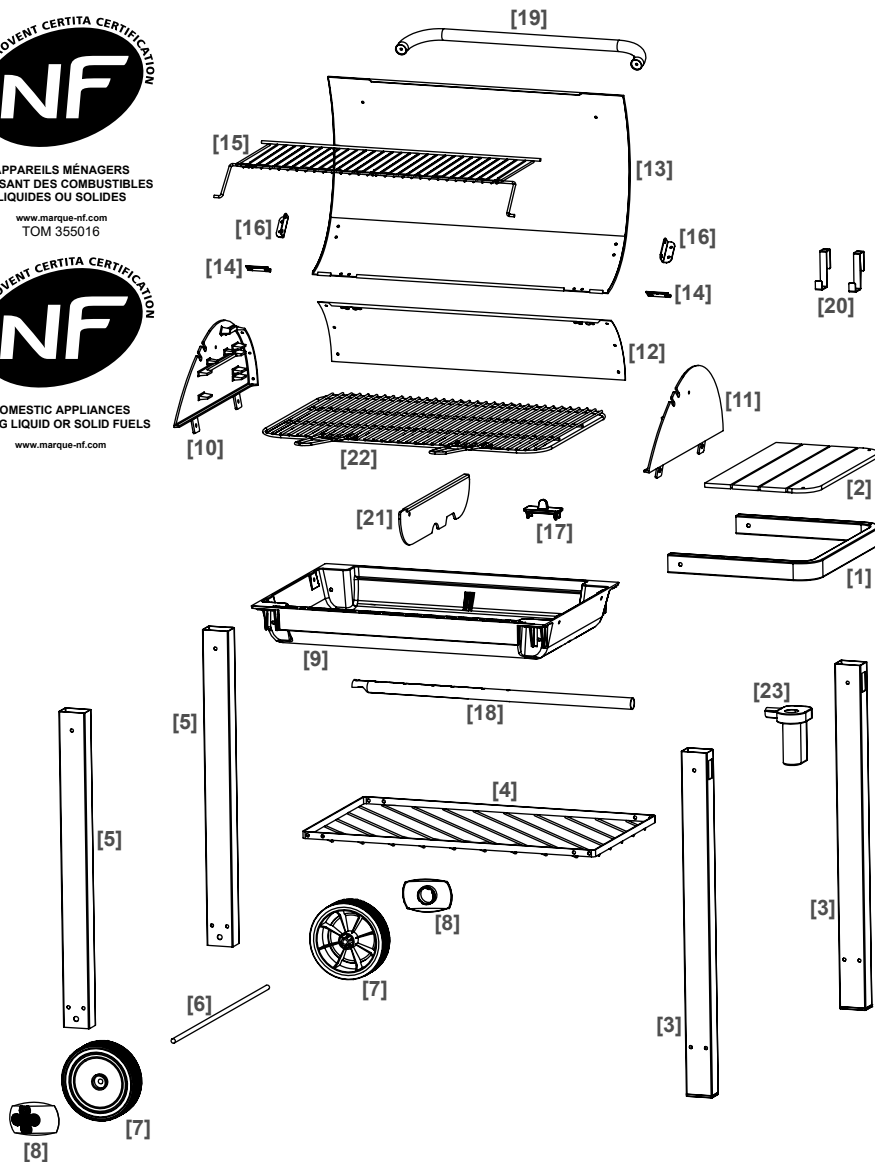

Estas instrucciones son para su seguridad. Léalas detenidamente antes de utilizar el producto y guárdelas para consultas futuras.

Vamos allá...



Cómo **empezar**

23

Antes de empezar

24

Seguridad

24



Y **en más detalle...**

25

Informaciones **técnicas y legales**

26

Cuidados y mantenimiento

27

Garantía

27

Montaje

44



Aunque esté impaciente para aprovechar plenamente los beneficios de su barbacoa, le recomendamos que lea atentamente este manual de uso. El contenido del mismo le proporcionará indicaciones importantes sobre la seguridad de la instalación, el uso y el mantenimiento.



Cómo empezar...

Antes de empezar

24

Seguridad

24

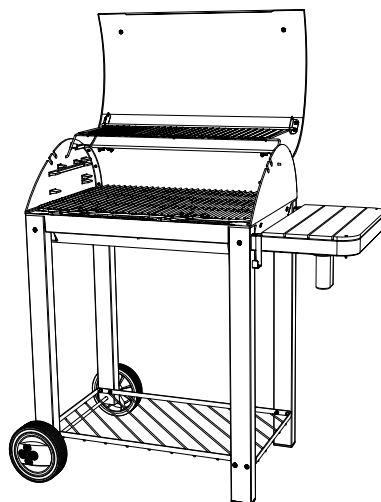

Comprobar



Compruebe que el contenido está completo e incluye todas las piezas y tornillos que figuran en la tabla de las pág. 2 - 3, así como las llaves que va a necesitar.

Su producto

1. La base
2. La cubeta
3. La parrilla calentaplatos
4. El ventilador
5. Tapa de protección

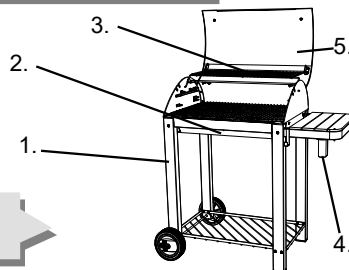

Para instalar el producto, siga la **secuencia de montaje** que figura al final de la guía.

Va a necesitar lo siguiente:

(elementos no incluidos)

Llave plana de 7



Llave plana de 10



Llave plana de 13

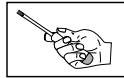

Seguridad

Compruebe que ha integrado todas las indicaciones que figuran a continuación.

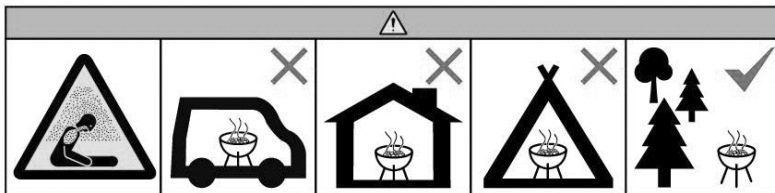

- No use la barbacoa en un espacio cerrado y/o habitable, p.e. vivienda, tienda de campaña, caravana, autocaravana, embarcación. Peligro de envenenamiento mortal por monóxido de carbono.
- ATENCIÓN: ÚNICAMENTE PARA USO EN EXTERIORES.** Las barbacoas no deben utilizarse en el interior de espacios cerrados ni bajo un cenador u otras estructuras exteriores parecidas, debido a la emisión de **MONÓXIDO DE CARBONO** y a los **RIESGOS DE INCENDIO**.
- Si el viento es fuerte, sitúe la barbacoa de forma que no se produzcan chispas.
- No rociar la cuba de hierro fundido con agua fría a fin de evitar un choque térmico.
- La barbacoa debe ser instalada sobre un soporte horizontal estable antes de su utilización.
- La barbacoa debe ser calentada y el combustible debe ser mantenido incandescente al menos 30 minutos antes de comenzar a cocinar.



Y en más **detalle...**

Informaciones técnicas y legales	26
Cuidados y mantenimiento	27
Garantía	27

Y en más detalle...

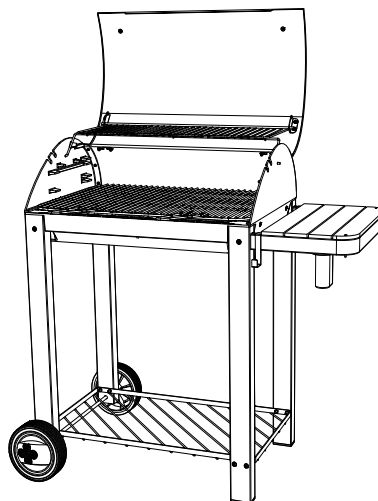

Características técnicas

Fabricado en Francia

Referencia proveedor: TOM 355016

Marca comercial: Blooma

Advertencias

Esta barbacoa tiene conformidad con la norma EN 1860-1.

Sin embargo, su uso exige un mínimo de vigilancia y precauciones.

Para su seguridad:

- > 1. ¡No utilizar en locales cerrados!
- > 2. **ATENCIÓN!** ¡No use alcohol o gasolina para encender o avivar el fuego!
- > 3. **ATENCIÓN!** ¡No deje la barbacoa al alcance de los niños y animales domésticos! Ya que todos los años se producen muchos accidentes relacionados con esto. Las quemaduras son especialmente graves para los niños ya que la cara les suele quedar a la altura del fuego dada su pequeña estatura.
- > 4. Si el viento es fuerte, sitúe la barbacoa de forma que no se produzcan chispas.
- > 5. No rociar la cuba de hierro fundido con agua fría a fin de evitar un choque térmico.
- > 6. La barbacoa debe ser instalada sobre un soporte horizontal estable antes de su utilización.
- > 7. La barbacoa debe ser calentada y el combustible debe ser mantenido incandescente al menos 30 minutos antes de comenzar a cocinar.
- > 8. **ATENCIÓN!** ¡Esta barbacoa se calentará mucho, no la mueva durante su utilización!

Algunos consejos:

- > 1. Antes de introducir el carbón en el fogón, recúbralo con papel de aluminio. De este modo, no sólo lo protegerá y resultará mucho más fácil de limpiar, sino que además el papel de aluminio actuará como reflector de calor.
- > 2. Ponga el carbón vegetal. Utilizar carbón de leña conforme con las normas vigentes de manera que el carbón se encuentre 2 cm por debajo de la parrilla en su posición de ajuste inferior.
- > 3. El método más fácil para encender el carbón vegetal es con los encendedores de barbacoas que se encuentran fácilmente en los comercios.
- > 4. Antes de comenzar a cocinar, verifique que el combustible está recubierto de cenizas.

cambio de la pila



MEDIO AMBIENTE: Si su barbacoa va equipada con un motor o un ventilador, no deseche ni incinere estos accesorios y siga las reglas de recogida selectiva, recuperación y reciclaje aplicables a estos productos.

Información sobre el uso de las pilas: Las pilas no recargables no deben recargarse. No mezclar pilas o acumuladores que no sean del mismo tipo. No mezclar pilas o acumuladores nuevos y usados. Utilizar únicamente las pilas o acumuladores del tipo recomendado o de tipo similar. Las pilas o acumuladores deben colocarse respetando la dirección de los bornes. Una mala colocación de las pilas puede causar daños al aparato. Los bornes de una pila o un acumulador no deben cortocircuitarse. No desechar las pilas: llévelas al centro de recogida selectiva más cercano.

Garantía

Blooma garantiza la barbacoa contra los defectos de fabricación o de los materiales durante el plazo de:

- 10 años para la cubeta de fundición, de fabricación francesa.
- 2 años para las otras piezas sueltas.

Esta garantía no cubre los defectos derivados de un mal montaje, un mal uso o un mal mantenimiento.

Tampoco cubre los daños o el deterioro de las piezas, debidos a un mal mantenimiento o al hecho de no haber respetado los consejos del manual.

Esta garantía pierde totalmente su validez si el producto ha sido modificado o se ha utilizado en condiciones anormales.

Esta garantía cubre apenas los defectos indicados arriba y que afecten directamente al uso de la barbacoa. No cubre el deterioro de la pintura o del acabado.

Ni el establecimiento ni el proveedor son responsables por los daños colaterales (directos o indirectos) que sufran bienes o personas.

Para beneficiarse de la garantía, el comprador debe informar al fabricante del problema que ha ocurrido y debe proporcionar:

- Una prueba de compra (tíquet de caja, factura...)
- Fotos que ilustren el problema
- La referencia de la pieza en cuestión (viene indicada en las páginas 2 y 3 del manual)
- La referencia de 13 cifras del producto.

Esta garantía se limita al cambio de la pieza defectuosa, que se le enviará sin costes.

Esta garantía se limita a un uso doméstico del producto.

En caso de problemas, póngase en contacto con su servicio de posventa. Le agradeceremos que no lleve la barbacoa a la tienda.



APPAREILS MÉNAGERS
UTILISANT DES COMBUSTIBLES
LIQUIDES OU SOLIDES

www.marque-nf.com
TOM 355016



DOMESTIC APPLIANCES
USING LIQUID OR SOLID FUELS

www.marque-nf.com

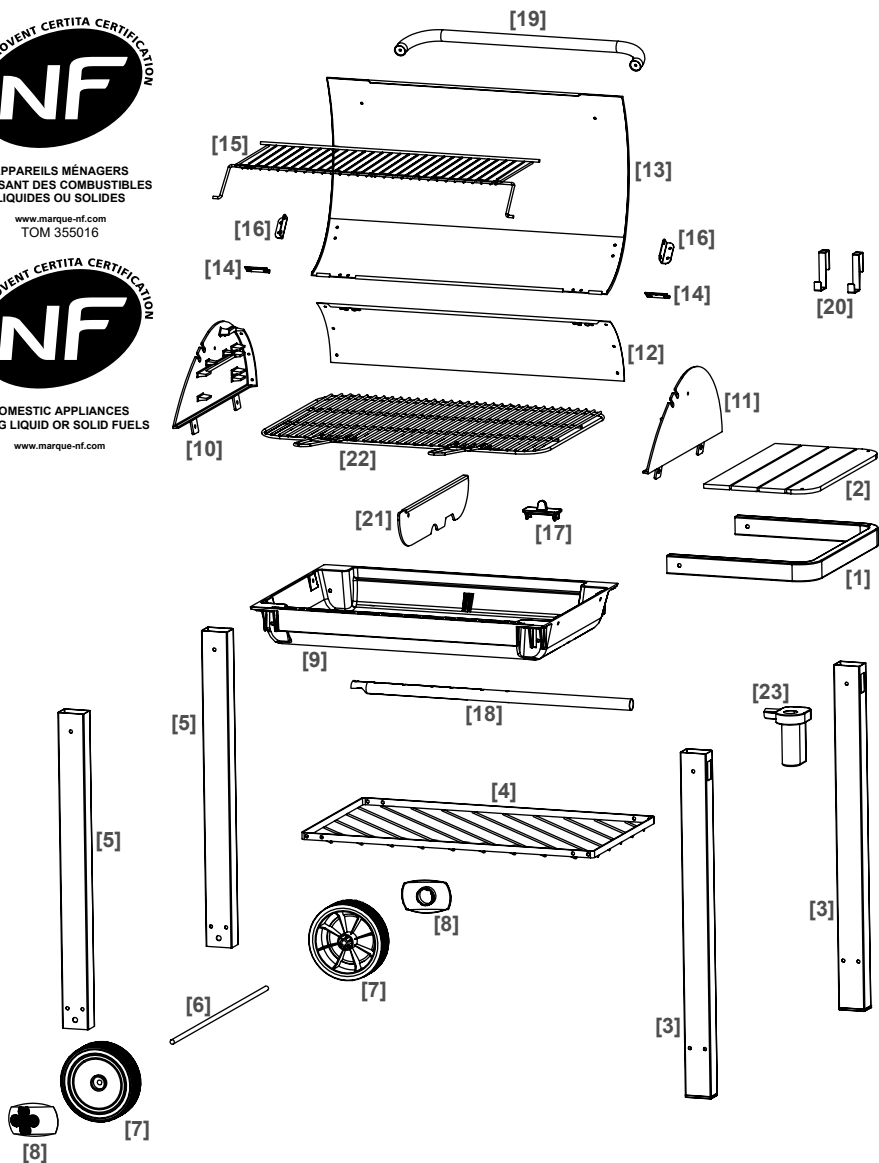

Estas instruções foram criadas a pensar na sua segurança. Leia-as com atenção antes da utilização e guarde-as para futuras referências.

E

começou...



Para começar bem...

31

Antes de começar

32

Segurança

32



Pormenorizadamente...

33

Informações **técnicas e legais**

34

Limpeza e manutenção

35

Garantia

35

Montagem

44



Seja qual for a sua pressa em desfrutar plenamente do seu grelhador, recomendamos que leia este manual com atenção. O seu conteúdo irá fornecer-lhe indicações importantes acerca da segurança de instalação, utilização e manutenção.



Para começar bem...

Antes de começar

32

Segurança

32

Para começar bem...

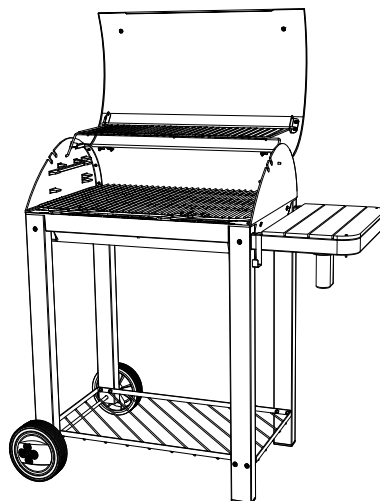

A verificar



Verifique o conteúdo, as peças e os parafusos apresentados na tabela na página 2 e as chaves de que necessita.

O seu produto

1. Os pés
2. A cuba
3. A grelha plana de aquecimento
4. Os foles
5. Cobertura de proteção

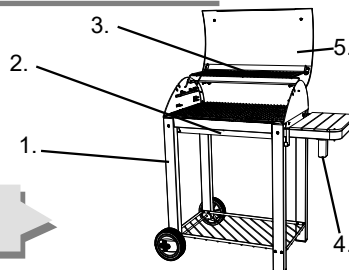

Para instalar o seu produto, consulte o manual de montagem no final do guia.

Precisa de:

(elementos não fornecidos)

Chave plana 7



Chave plana 10



Chave plana 13



Segurança

Certifique-se de que segue todas as instruções apresentadas em baixo:

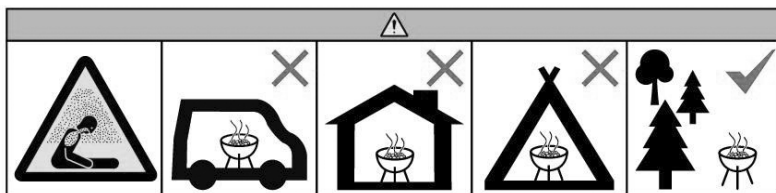

- Não utilizar o churrasco num espaço confinado e/ou habitável, por exemplo em casa, tendas, caravanas, camping-cars, barcos. Risco de morte por envenenamento por monóxido de carbono.
- AVISO: APENAS PARA UTILIZAÇÃO NO EXTERIOR, os grelhadores não devem ser utilizados no interior de espaços fechados ou por baixo de um caramanchão, nem em qualquer estrutura exterior semelhante, devido à libertação de MONÓXIDO DE CARBONO e RISCOS DE INCÊNDIOS..
- Em dias de vento forte, coloque a sua churrasqueira de maneira a que o vento não levante brasas.
- Não aspergir uma cuba com água fria a fim de evitar um choque térmico.
- Antes de utilizar o grelhador, coloque-o sobre um suporte horizontal estável.
- Antes de fazer o primeiro assado, aqueça o grelhador e mantenha o combustível incandescente durante um período mínimo de 30 minutos.



Pormenorizadamente...

Informações técnicas e legais	34
Limpeza e manutenção	35
Garantia	35

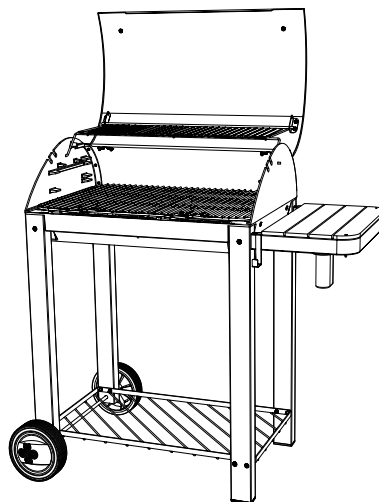

Características técnicas

Fabricado em França

Referência do fornecedor: TOM 355016

Marca comercial: Blooma

Avisos

Este grelhador encontra-se em conformidade com a norma EN 1860-1. No entanto, a sua utilização exige um mínimo de supervisão e de precauções.

Para sua segurança:

- > 1. AVISO! - Não utilizar dentro de casa!
- > 2. AVISO! - Não utilizar álcool nem petróleo para acender ou reacender!
- > 3. AVISO! - Manter as crianças e os animais de estimação afastados. Todos os anos há um grande número de acidentes. As queimaduras são particularmente graves nas crianças porque, devido à sua pequena estatura, as suas faces se encontram quase sempre à altura das chamas.
- > 4. Em dias de vento forte, coloque a sua churrasqueira de maneira a que o vento não levante brasas.
- > 5. Não aspergir uma cuba com água fria a fim de evitar um choque térmico.
- > 6. Antes de utilizar o grelhador, coloque-o sobre um suporte horizontal estável.
- > 7. Antes de fazer o primeiro assado, aqueça o grelhador e mantenha o combustível incandescente durante um período mínimo de 30 minutos.
- > 8. AVISO! Esta churrasqueira aquece muito, não tocar enquanto estiver em uso.

Alguns conselhos:

- > 1. Antes de introduzir o carvão no queimador, cubra-o com uma folha de alumínio. Desta forma, não só o protegerá e será mais fácil de limpar, mas a folha de alumínio servirá igualmente de reflector de calor.
- > 2. Introduza o carvão de madeira. Utilizar carvão de lenha de acordo com as normas vigentes, de maneira a que o carvão se encontre a uma distância de 2 cm por debaixo da grelha na sua posição de ajuste inferior.
- > 3. O método mais utilizado para acender o carvão de madeira é o de utilizar acendalhas para churrasqueira, as quais se encontram com facilidade nas lojas comerciais.
- > 4. Não cozinhar antes do combustível ter um revestimento de cinza.

Substituição das pilhas



AMBIENTE: Se o seu grelhador vier equipado com um motor ou conjunto de foles, não elimine nem queime estes acessórios. Siga as regras de recolha, recuperação e reciclagem aplicável a estes produtos.

Informação acerca da utilização das pilhas: Não recarregue pilhas não recarregáveis. Não misture pilhas ou acumuladores que não sejam do mesmo tipo. Não misture pilhas ou acumuladores novos com usados. Utilize apenas pilhas ou acumuladores do tipo recomendado ou de um tipo semelhante. As pilhas ou acumuladores devem ser instalados com a polaridade correta. Uma má posição pode danificar o aparelho. Não coloque os terminais das pilhas ou acumuladores em curto-circuito. Não deite fora as pilhas: Entregue-as no ponto de recolha mais próximo.

Garantia

A Blooma oferece uma garantia do produto contra danos de fabrico ou defeitos de material durante:

- 10 anos para a cuba em ferro fundido de fabrico francês.
- 2 anos para as outras peças amovíveis.

Esta garantia não abrange defeitos ligados a uma má montagem, má utilização ou má manutenção.

Ela também não abrange danos ou deterioração de peças devido a uma má manutenção ou se os conselhos do manual não forem respeitados.

Esta garantia perde a sua validade se o produto for modificado ou utilizado em condições anormais.

Esta garantia abrange apenas os defeitos mencionados anteriormente que tenham um impacto direto na utilização do grelhador. Ela não abrange deteriorações da tinta ou do acabamento.

A loja e o fornecedor não se responsabilizam por danos colaterais (diretos ou indiretos) em bens ou pessoas.

Para beneficiar da garantia, o comprador deve informar o fabricante do produto ocorrido e deve fornecer:

- Uma prova de compra (talão da caixa, fatura...)
- Fotos a ilustrar o problema
- A referência da peça abrangida (indicada na página 2 e 3 do seu manual)
- A referência de 13 algarismos do produto

Esta garantia limita-se à substituição da peça defeituosa, que lhe será enviada sem quaisquer custos.

Esta garantia limita-se a um uso doméstico do produto. No caso de problemas, contacte o seu serviço pós-venda.

Por favor, não leve o grelhador para a loja.



APPAREILS MÉNAGERS
UTILISANT DES COMBUSTIBLES
LIQUIDES OU SOLIDES
www.marque-nf.com
TOM 355016



DOMESTIC APPLIANCES
USING LIQUID OR SOLID FUELS
www.marque-nf.com

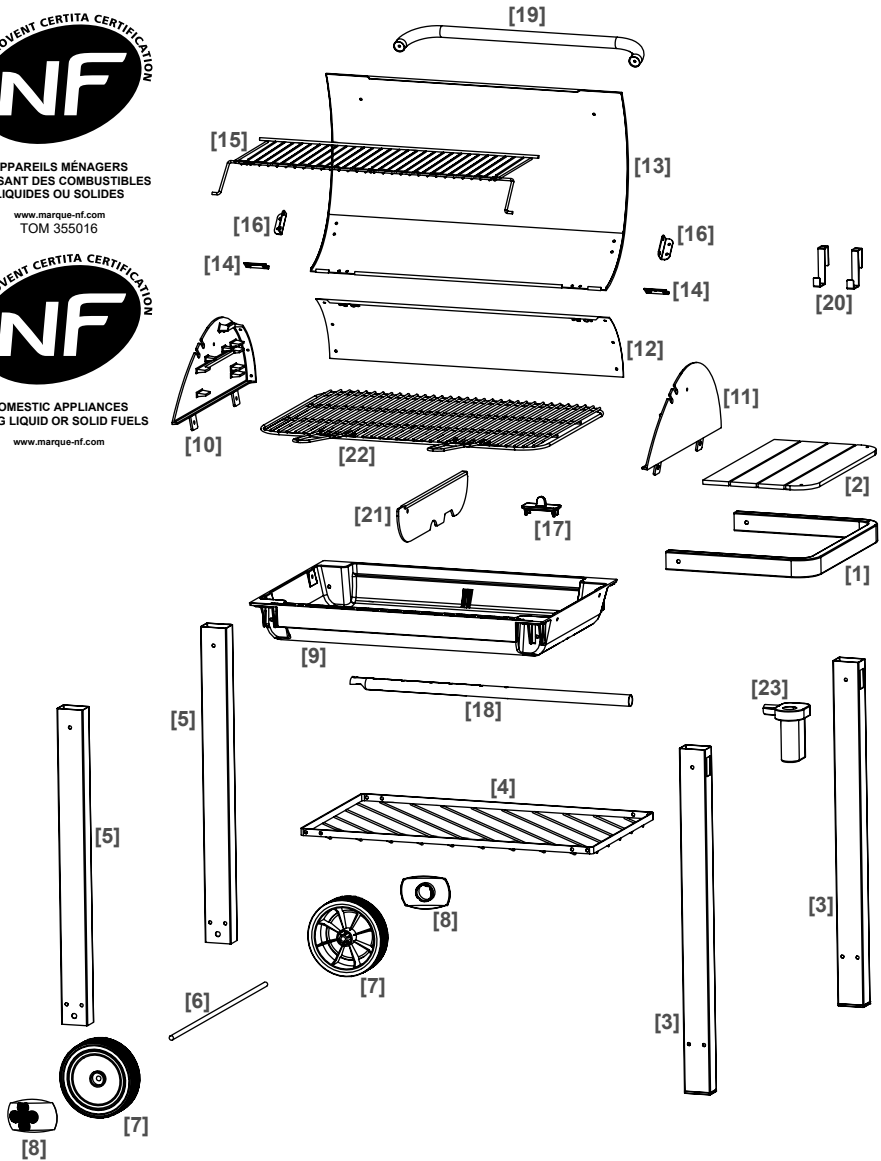

Bu talimatlar sizin güvenliğinizi içindir. Kullanmadan önce dikkatlice okuyun ve gelecekte başvuru amacıyla saklayın.

Başlarken...



Başlarke

39

Başlamadan önce
G venlik

40

40



Daha **detaylı** olarak...

41

Teknik **ve** yasal **bilgiler**
Temizlik **ve** **bakım**
Garanti

42

43

43

Montaj

44



Barbek n z  tam olarak kullanmaya bařlamadan  nce, bu kılavuzu dikkatlice okumanızı  neririz. Kılavuz g venli montaj, kullanım ve bakım hakkında  nemli bilgiler i ermektedir.



Başlarken...

Başlarken...

Başlamadan önce	40
Güvenlik	40

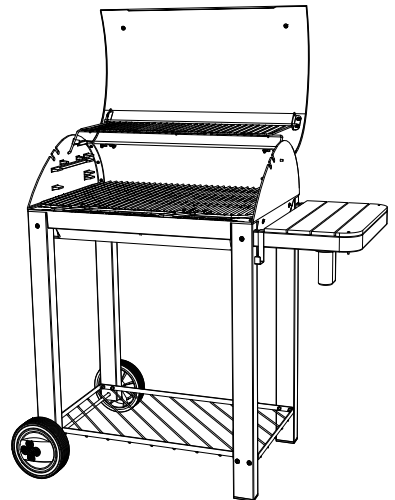

Kontrol edilecekler



Paket içeriğini, parçaları, sayfa 2'de gösterilen vidaları ve ihtiyacınız olan anahtarları kontrol edin.

Ürününüz

1. Taban
2. Hazne
3. Düz yüzeyli ısıtma ızgarası
4. Havalandırma kanalı
5. Koruyucu kapak

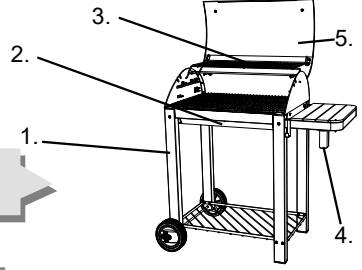

Ürününüzü monte etmek için, kılavuzun sonunda yer alan **montaj sırası** bölümüne bakın.

İhtiyaç duyacağınız aletler:

(ürünle birlikte verilmeyen aletler)

Açık ağız anahtar - 7



Açık ağız anahtar - 10



Açık ağız anahtar - 13

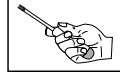

Güvenlik

Aşağıdaki talimatların tümüne uyduğunuzdan emin olun:

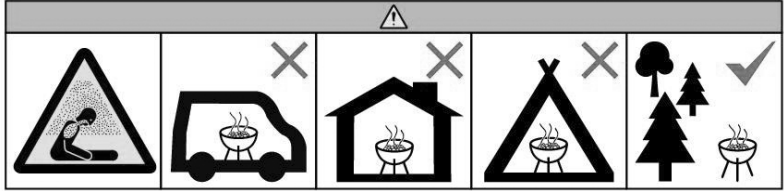

- ✓ Mangalı kapalı ve/veya meskûn bir alanda (örneğin, evler, çadırlar, kamperler, tekneler, veya her türlü kapalı mekân). Karbon monoksit ile zehirlenerek ölme riski vardır.
- ✓ **UYARI: SADECE AÇIK HAVADA KULLANIN**, barbeküer KARBONMONOKSİT salınımı ve **YANGIN RİSKİ** nedeniyle kapalı alanlarda, çardak altında veya benzer tüm açık hava yapılarında kullanılmamalıdır.
- ✓ Çoklu rüzgarlı bir günde, barbekünüzü kıvılcımların çıkmayacağı şekilde konumlandırın.
- ✓ Termik şoku önlemek amacıyla döküm tekneye soğuk su püskürtmeyin.
- ✓ Kullanımdan önce barbekü dengeli düz bir yüzeye yerleştirilmelidir.
- ✓ İlk pişirme işleminden önce barbekü ısıtılmalı ve yakıt en az 30 dakika boyunca korlaştırılmalıdır.



Daha **detaylı** olarak...

Teknik ve yasal bilgiler	42
Temizlik ve bakım	43
Garanti	43

Daha **detaylı** olarak...

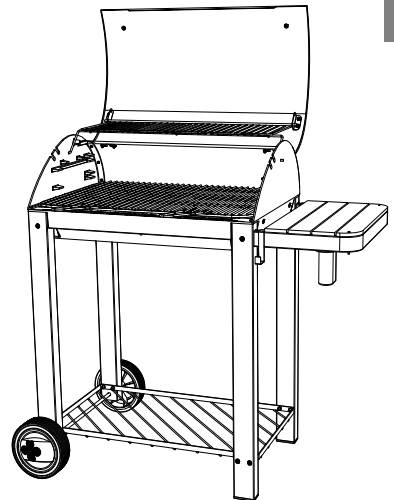

Teknik özellikler

Fransa'da üretilmiştir

Tedarikçi referansı: TOM 355016

Ticari marka: Blooma

Uyarılar

Bu barbekü EN 1860-1 standardı ile uyumludur. Bununla birlikte, kullanımı minimum düzeyde gözetim ve önlem gerektirir.

Güvenliğiniz için:

- > 1. İç mekânda kullanmayın!
- > 2. UYARI! Yakmak ya da tekrar yakmak için ispirto veya benzin kullanmayın!
- > 3. UYARI! Çocukları ve hayvanları yaklaştırmayın. Her yıl maalesef ki bu konularda büyük miktarda kazalar olmaktadır. Yanıklar özellikle çocuklarda daha ciddi boyutta çünkü çocukların boyları kısa ve yüzleri neredeyse mangal ile aynı hizadadır.
- > 4. Çoklu rüzgarlı bir günde, barbekünüzü kıvılcımların çıkmayacağı şekilde konumlandırın.
- > 5. Termik şoku önlemek amacıyla döküm tekneye soğuk su püskürtmeyin.
- > 6. Kullanımdan önce barbekü dengeli düz bir yüzeye yerleştirilmelidir.
- > 7. İlk pişirme işleminden önce barbekü ısıtılmalı ve yakıt en az 30 dakika boyunca korlaştırılmalıdır.
- > 8. UYARI! Barbekü çok sıcak olacaktır, işlem esnasında hareket ettirmeyin.

Birkaç ipucu:

- > 1. Mangala kömür eklemeyen önce, mangalı bir kat alüminyum folyo ile kaplayın. Böylece sadece mangalı korumuş olmayacak ve temizliğini kolaylaştırmış olacaksınız, ayrıca folyo ısıyı da yansıtacaktır.
- > 2. Ardından, odun kömürünü koyun. Yürürlükteki normlara uygun odun kömürü kullanın, yani odun kömürü yatay konumda pişirme ızgarasının 2 cm altında olmalıdır.
- > 3. Odun kömürünü yakmanın en kolay yolu marketlerde rahatlıkla bulabileceğiniz ve kesinlikle tehlikesi bulunmayan barbekü ateşleyicileri kullanmaktır.
- > 4. Yakacak külle kaplanmadan önce pişirme işlemine başlamayın.

Pilin değiştirilmesi



ÇEVRE: Barbekünüz bir motor veya havalandırma kanalı ile donatılmışsa, bu aksesuarları atmayın veya yakmayın, bu ürünler için geçerli toplama, geri kazanım ve geri dönüşüm yönetmeliklerine uyun.

Pillerin kullanımı ile ilgili bilgiler: Şarj edilebilir özellikte olmayan piller yeniden şarj edilmemelidir. Farklı tipteki pil veya akümülatörler karışık olarak kullanılmamalıdır. Yeni ve kullanılmış pil veya akümülatörler karışık olarak kullanılmamalıdır. Sadece önerilen veya benzer tipte pil veya akümülatörler kullanılmalıdır. Pil veya akümülatörler kutup yönlerine dikkat edilerek yerleştirilmelidir. Hatalı yerleştirme cihazda hasara neden olabilir. Pil veya akümülatör terminalleri kısa devre edilmemelidir. Pilleri atmayın: en yakın toplama noktasına bırakın.

Garanti

Barbekü, Blooma tarafından üretim veya malzeme hatalarına karşı aşağıdaki periyotlar süresince garanti altındadır:

- Fransa'da üretilen dökme demir hazne için 10 yıl.
- Diğer yedek parçalar için 2 yıl.

Bu garanti hatalı montaj, yanlış kullanım ya da doğru yapılmayan bakım nedeniyle oluşan hataları kapsamaz.

Ayrıca hatalı bakım veya kılavuzda yer alan talimatlara uyulmaması sonucu parçalarda oluşan hasar veya bozulmalar garanti kapsamında değildir.

Ürün üzerinde değişiklik yapılması veya anormal şartlarda kullanım durumunda, bu garanti geçerli olmayacaktır.

Garanti sadece barbekünün kullanımını doğrudan etkileyen ve yukarıda bahsedilen hataları kapsar. Boya veya son kat (yüzey) hasarlarını kapsamaz.

Mağaza ve tedarikçi, mal veya kişiler üzerinde oluşacak tali hasarlardan (doğrudan veya dolaylı) sorumlu değildir.

Garanti hizmetinden yararlanmak için, ürünü satın alan kişi meydana gelen sorunu üreticiye bildirmeli ve aşağıdaki bilgi ve belgeleri vermelidir:

- Satın alma belgesi (makbuz, fiş, fatura ...)
- Sorunu gösteren fotoğraflar
- İlgili parçanın referansı (elinizdeki kılavuzun sayfa 2 ve 3'ünde gösterilen)
- 13 haneli ürün referans numarası.

Bu garanti, size ücretsiz gönderilecek olan arızalı parçanın değiştirilmesi ile sınırlıdır.

Bu garanti, ürünün ev içinde kullanımı ile sınırlıdır.

Sorun olması durumunda, lütfen satış sonrası müşteri hizmetleri ile irtibata geçin. Lütfen barbeküyü mağazaya geri getirmeyin.

Daha detaylı olarak...

01

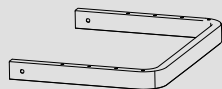

[1]

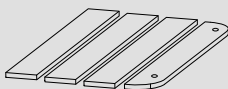

[2]



[27] x 2



[34] x 2

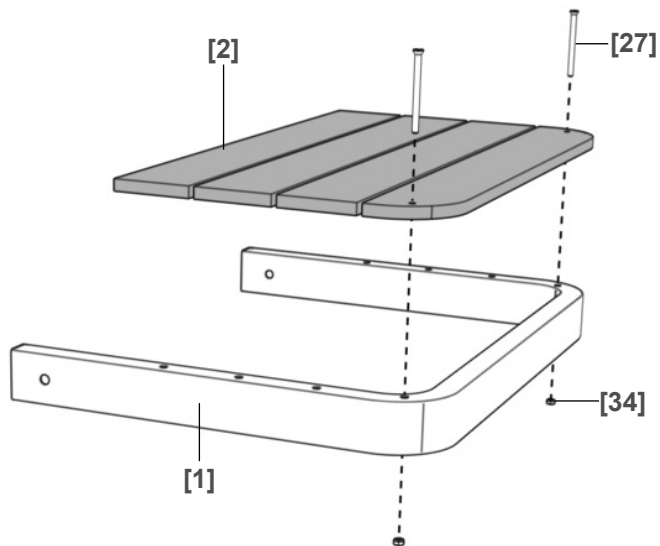

02



[3] x 2



[28] x 4

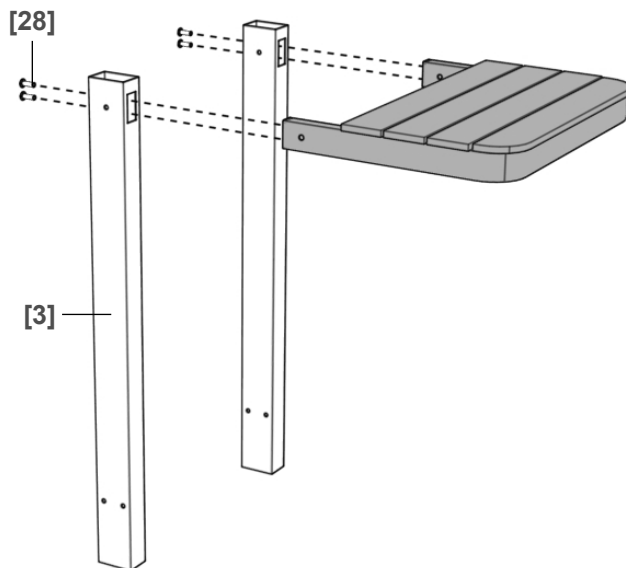

- FR Serrer l'ensemble des vis.
- EN Tighten all of the screws.
- ES Apretar el conjunto de tornillos.
- PT Aperte todas as porcas.
- TR Tüm vidaları sıkın.

03

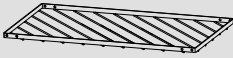

[4]

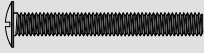

[29] x 4



[30] x 4

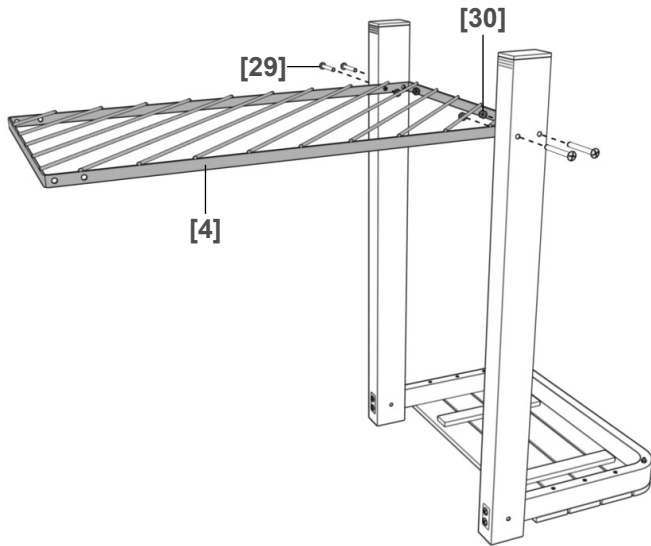

04

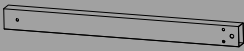

[5] x 2

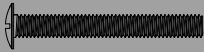

[29] x 4



[30] x 4

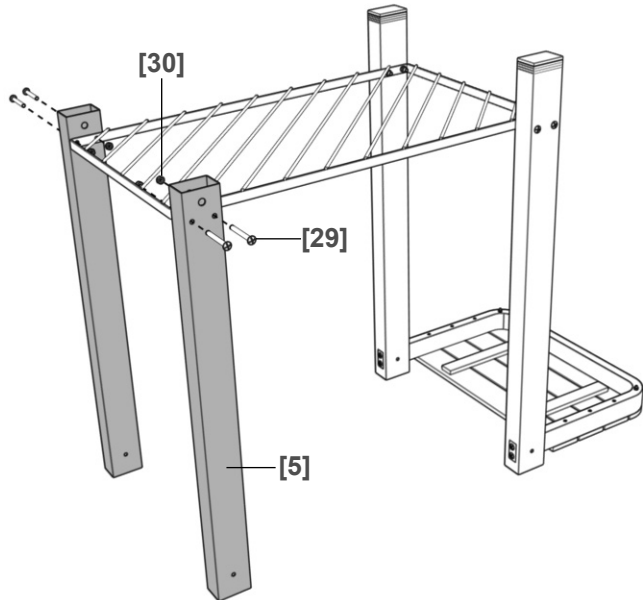

- FR | Serrer l'ensemble des vis.
- EN | Tighten all of the screws.
- ES | Apretar el conjunto de tornillos.
- PT | Aperte todas as porcas.
- TR | Tüm vidaları sıkın .

05

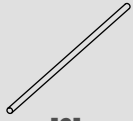

[6]



[7] x 2



[8] x 2



[31] x 2

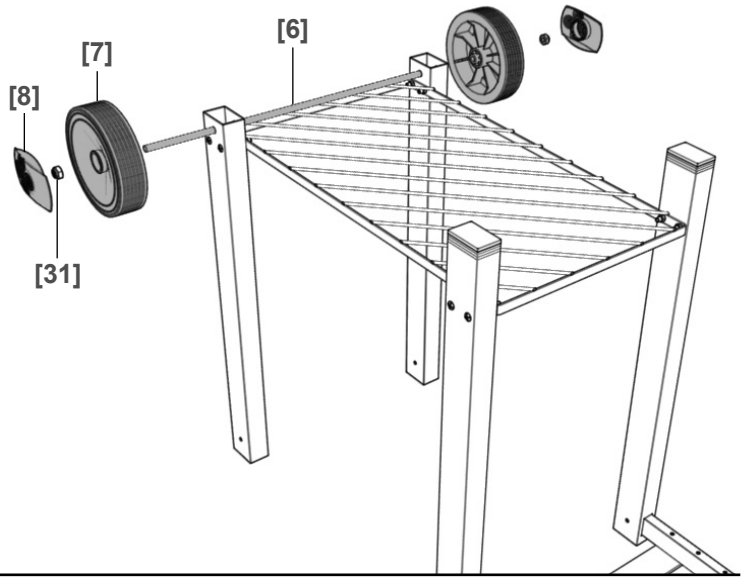

06

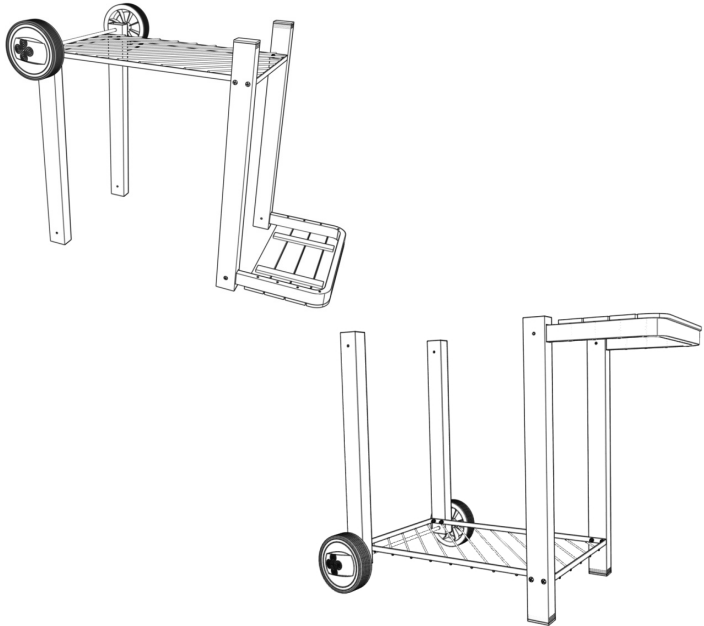

- FR | Serrer l'ensemble des écrous.
- EN | Tighten all of the nuts.
- ES | Apretar el conjunto de tuercas.
- PT | Aperte todas as porcas.
- TR | Tüm somunları sıkın.

07



[9]



[32] x 4



[30] x 4

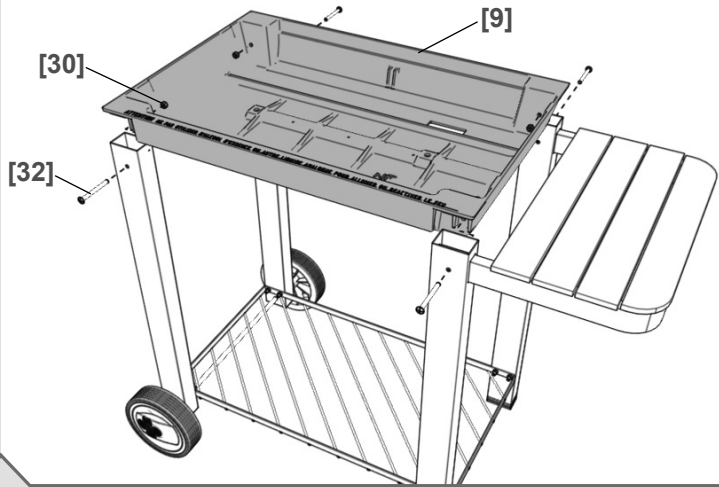

- FR | Serrer l'ensemble des écrous.
EN | Tighten all of the nuts.
ES | Apretar el conjunto de tuercas.
PT | Aperte todas as porcas.
TR | Tüm somunları sıkın.

08

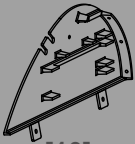

[10]

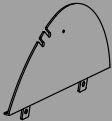

[11]



[28] x 4



[30] x 4

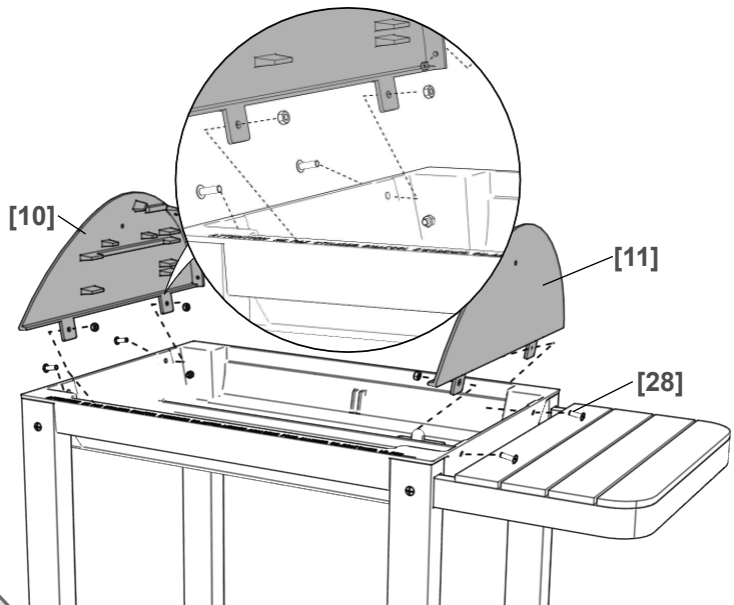

- FR | Ne pas serrer les joues 10 et 11 durant le montage de la pièce 12.
EN | Do not tighten sets 10 and 11 while fitting part 12 .
ES | No apretar las carrileras 10 y 11 durante el montaje de la pieza 12.
PT | Não aperte as frentes 10 e 11 durante a montagem da peça 12.
TR | 12 numaralı parçayı monte ederken 10 ve 11 yanaklarını sıkmayın.

09

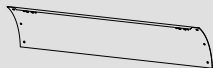

[12]



[33] x 6



[34] x 6

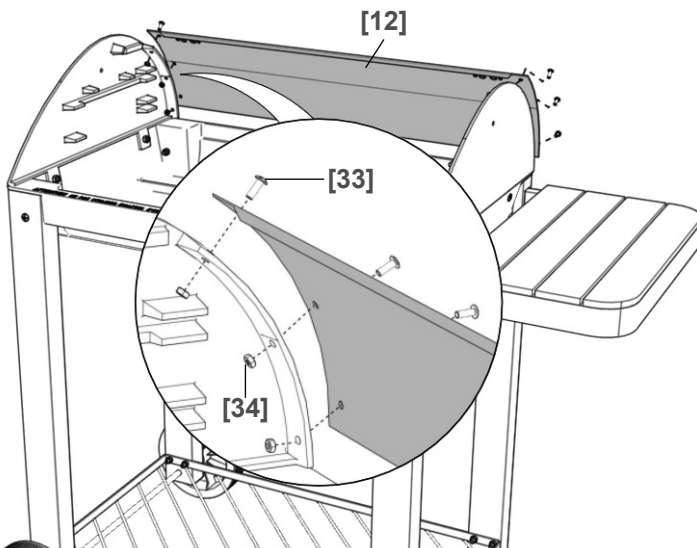

- FR Serrer l'ensemble des écrous.
- EN Tighten all of the nuts.
- ES Apretar el conjunto de tuercas.
- PT Aperte todas as porcas.
- TR Tüm somunları sıkın.

10

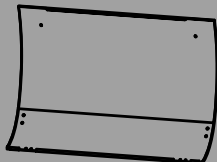

[13]



[14] x 2



[33] x 8



[35] x 8



[34] x 8

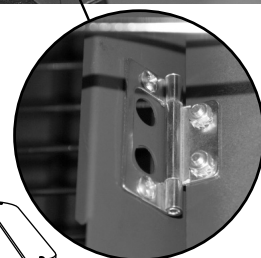
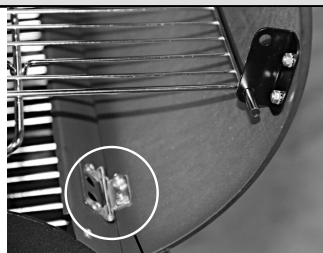
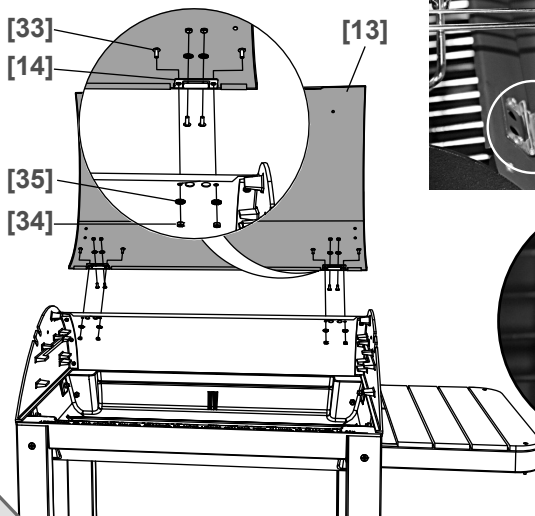

- FR Serrer l'ensemble des écrous.
- EN Tighten all of the nuts.
- ES Apretar el conjunto de tuercas.
- PT Aperte todas as porcas.
- TR Tüm somunları sıkın.

11

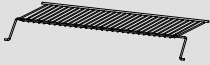

[15]



[16] x 2



[33] x 4



[35] x 4



[34] x 4

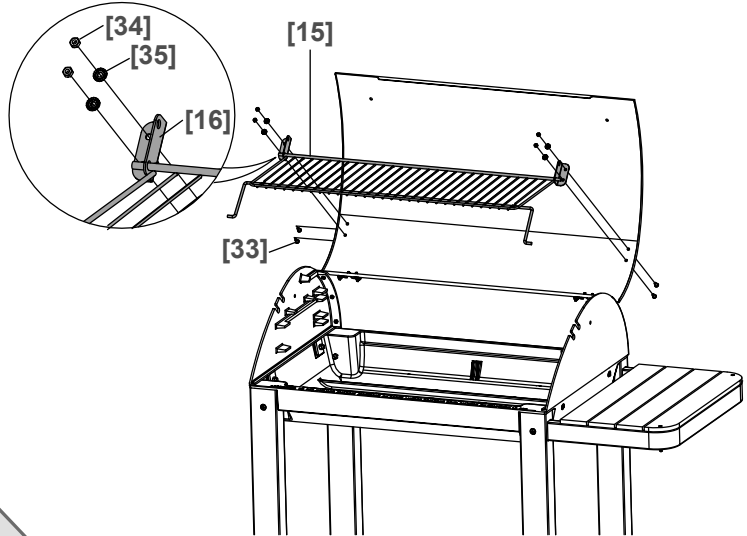

- FR Serrer l'ensemble des écrous.
- EN Tighten all of the nuts.
- ES Apretar el conjunto de tuercas.
- PT Aperte todas as porcas.
- TR Tüm somunları sıkın.

12



[17]



[18]



[28] x 1

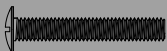

[36] x 1



[30] x 2

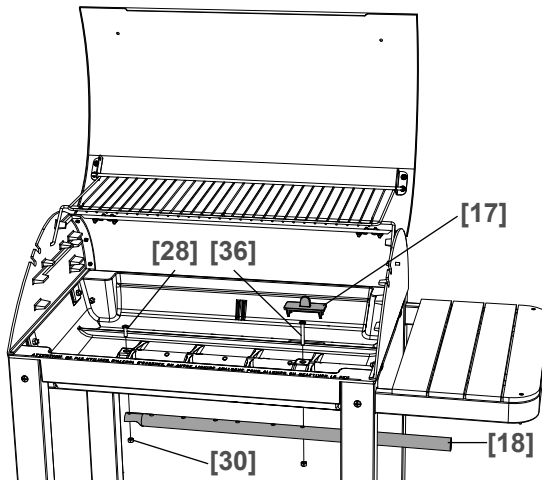

- FR Assurez-vous que les cendres soient complètement froides avant de manipuler la plaque vide-cendre N°17
Serrer l'ensemble des écrous.
- EN Ensure that the ashes are completely cold before handling the ash collector No. 17
Tighten all of the screws.
- ES Asegúrese de que las cenizas estén totalmente frías antes de manipular la placa vacía cenizas n° 17. Apretar el conjunto de tornillos.
- PT Certifique-se de que a cinza está completamente fria antes de manusear a placa de esvaziamento da cinza n° 17.
Aperte todos os parafusos.
- TR Kül boşaltma plakası N°17 ellenmeden önce küllerin tamamen soğuk olduğundan emin olun.
Tüm vidaları sıkın.

13

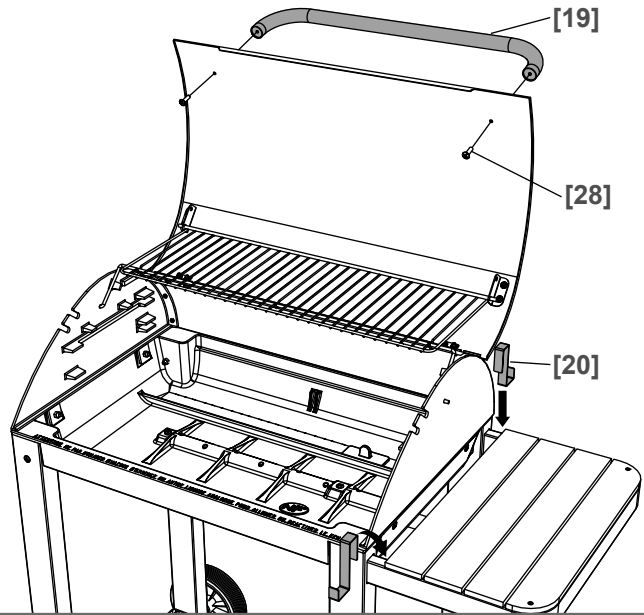
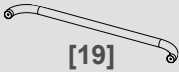

- FR Serrer l'ensemble des vis et des écrous.
EN Tighten all of the screws and nuts.
ES Apretar el conjunto de tornillos y tuercas.
PT Aperte todos os parafusos e porcas.
TR Tüm vidaları ve somunları sıkın.

14

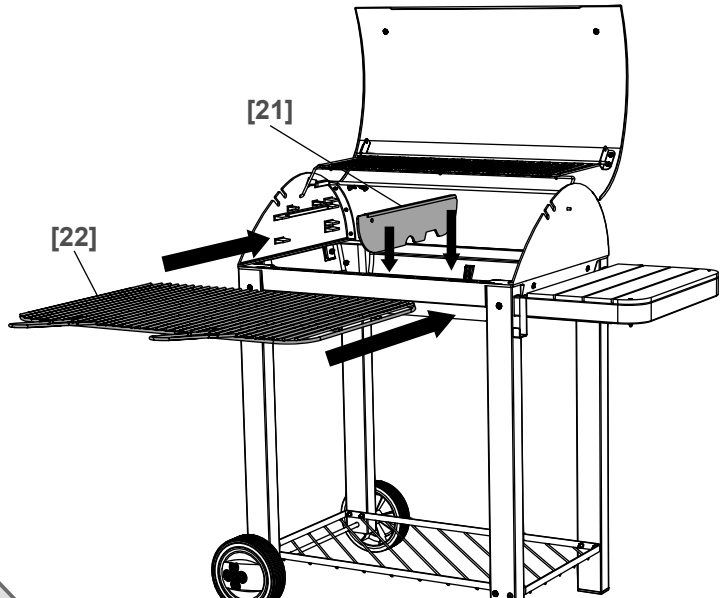
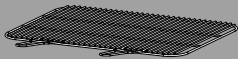
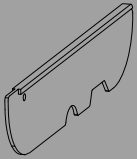

FR

15



[23]

Le couvercle sert uniquement de protection
The hood is for protective purposes only.
La tapa sirve solo de protección.
A tampa serve apenas de proteção.
Kapak sadece koruma amaçlıdır.

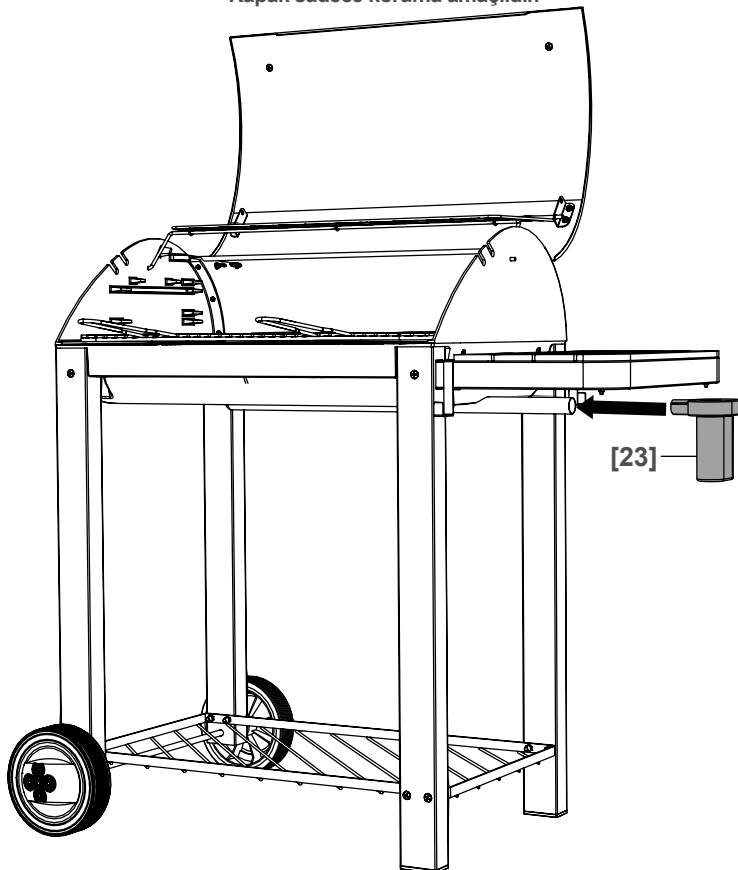

- FR** La soufflerie fonctionne grâce à deux piles de 1,5 volt référence LR 20 (Durée de service environ 10 heures, pile non fournie). Lorsque vous n'utilisez pas la soufflerie, enlevez celle-ci du tube, afin d'éviter sa détérioration. Ne jamais utiliser la soufflerie au delà de 5 minutes.
- EN** The blower operates from two 1.5 volt batteries, reference LR 20 (battery life approximately 10 hours, battery not included). When you are not using the blower, remove it from the tube to prevent it from becoming damaged. Never used the blower for more than 5 minutes.
- ES** El ventilador funciona gracias a dos pilas de 1,5V, de la referencia LR20 (con una duración aproximada de 10 horas). Pila no incluidas. Cuando no use el ventilador, retirelo del tubo para evitar que se deteriore. No utilice nunca el ventilador durante más de 5 minutos.
- PT** Os foles funcionam graças a duas pilhas de 1,5 volts, referência LR 20 (Duração de funcionamento de cerca de 10 horas, pilha não fornecida). Quando não utilizar os foles, retire-os do tubo, de modo a evitar a sua deterioração. Nunca utilize os foles durante mais de 5 minutos.
- TR** Havalandırma iki adet LR 20 tip 1,5 volt pil ile çalışır (çalışma süresi: yaklaşık 10 saat, pil ürüne dahil değildir). Havalandırmayı kullanmadığınızda, hasari önlemek için borudan çıkarın. Havalandırma yası 5 dakikadan fazla kullanmayın.

EN **B&Q plc**, Chandlers Ford, Hants, SO53 3LE
United Kingdom www.diy.com
SFD Limited, Trade House, Mead Avenue,
Yeovil, BA22 8RT, United Kingdom

FR **Castorama France** C.S. 50101 Templemars
59637 Wattignies CEDEX www.castorama.fr
BRICO DÉPÔT 30-32 rue de la Tourelle
91310 Longpont-sur-Orge France
www.bricodepot.com

PL **Producent:**
Castorama Polska Sp. z o. o.
ul. Krakowiaków 78
02-255 Warszawa,
www.castorama.pl

RU **Импортер:**
ООО "Касторама РУС"
Дербеневская наб.,
дом 7, стр 8
Россия, Москва, 115114
www.castorama.ru

Изготовитель для России:
Джиэфси Хардваре Элек Эпплайнс Фактори
Адрес: Байксинг Ист Роад Байтанг Лонггуй
Таун Байюн Гуангжоу, Кнр.

ES **Euro Depot España, S.A.U.**
c/ La Selva, 10
Edificio Inblau A 1a Planta
08820-El Prat de Llobregat
www.bricodepot.es

TR **İthalatçı Firma :**
KOÇTAŞ YAPI
MARKETLERİ TİC. A.Ş.
Tasdelen mah. Sırrı Çelik
Bulvarı No: 5
34788 Tasdelen
Çekmeköy/İSTANBUL
Tel: +90 216 4300300
Faks: +90 216 4844313
www.koctas.com.tr
KOÇTAŞ MÜŞTERİ HİZMETLERİ
0850 209 50 50