

**MAC  
ALLISTER**

# 2400W Electric Chain Saw

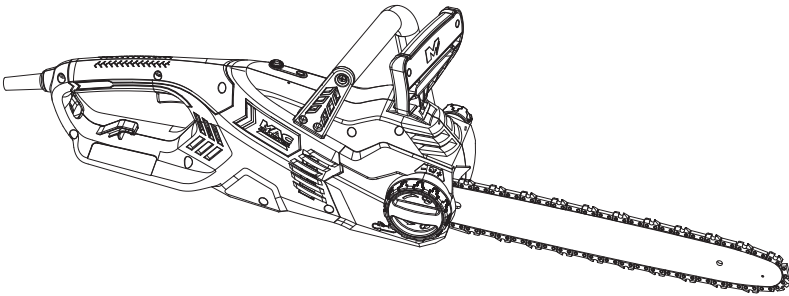

**MCSWP2400S-2**

**EAN: 3663602627487**



**WARNING: Read the instructions before using the product!**

# Let's get started...

These instructions are for your safety. Please read through them thoroughly before use and retain them for future reference.



## Getting started...

02

**Safety** information 03

Your **product** 15

**Before** you start 16



## In more detail...

25

**Product** functions 26

**Operation** 29

**Care** and maintenance 36

**Trouble** shooting 42

**Recycling** and disposal 43

**Guarantee** 44

Technical **specifications** 45

**EC** declaration of conformity 47

## Safety warnings

### General power tool safety warnings



**WARNING!** Read all safety warnings and all instructions. Failure to follow the warnings and instructions may result in electric shock, fire and/or serious injury. Save all warnings and instructions for future reference. The term “power tool” in the warnings refers to your mains-operated (corded) power tool or battery-operated (cordless) power tool.

### Work area safety

- 1. Keep work area clean and well lit.** Cluttered or dark areas invite accidents.
- 2. Do not operate power tools in explosive atmospheres, such as in the presence of flammable liquids, gases or dust.** Power tools create sparks which may ignite the dust or fumes.
- 3. Keep children and bystanders away while operating a power tool.** Distractions can cause you to lose control.

### Electrical safety

- 1. Power tool plugs must match the outlet.** **Never modify the plug in any way.** Do not use any adapter plugs with earthed (grounded) power tools. Unmodified plugs and matching outlets will reduce risk of electric shock.
- 2. Avoid body contact with earthed or grounded surfaces, such as pipes, radiators, ranges and refrigerators.** There is an increased risk of electric shock if your body is earthed or grounded.
- 3. Do not expose power tools to rain or wet conditions.** Water entering a power tool will

increase the risk of electric shock.

4. **Do not abuse the cord. Never use the cord for carrying, pulling or unplugging the power tool.** Keep cord away from heat, oil, sharp edges or moving parts. Damaged or entangled cords increase the risk of electric shock.
5. **When operating a power tool outdoors, use an extension cord suitable for outdoor use.** Use of a cord suitable for outdoor use reduces the risk of electric shock.
6. **If operating a power tool in a damp location is unavoidable, use a residual current device (RCD) protected supply.** Use of an RCD reduces the risk of electric shock.

### Personal safety

1. **Stay alert, watch what you are doing and use common sense when operating a power tool.** Do not use a power tool while you are tired or under the influence of drugs, alcohol or medication. A moment of inattention while operating power tools may result in serious personal injury.
2. **Use personal protective equipment. Always wear eye protection.** Protective equipment such as dust mask, non-skid safety shoes, hard hat, or hearing protection used for appropriate conditions will reduce personal injuries.
3. **Prevent unintentional starting. Ensure the switch is in the off-position before connecting to power source and/or battery pack, picking up or carrying the tool.** Carrying power tools with your finger on the switch or energising power tools that have the switch on invites accidents.
4. **Remove any adjusting key or wrench before turning the power tool on.** A wrench or a key left attached to a rotating part of the power tool may result in personal injury.
5. **Do not overreach.** Keep proper footing and

balance at all times. This enables better control of the power tool in unexpected situations.

- 6. Dress properly. Do not wear loose clothing or jewellery.** Keep your hair, clothing and gloves away from moving parts. Loose clothes, jewellery or long hair can be caught in moving parts.
- 7. If devices are provided for the connection of dust extraction and collection facilities, ensure these are connected and properly used.** Use of dust collection can reduce dust-related hazards.

### Power tool use and care

- 1. Do not force the power tool. Use the correct power tool for your application.** The correct power tool will do the job better and safer at the rate for which it was designed.
- 2. Do not use the power tool if the switch does not turn it on and off.** Any power tool that cannot be controlled with the switch is dangerous and must be repaired.
- 3. Disconnect the plug from the power source and/or the battery pack from the power tool before making any adjustments, changing accessories, or storing power tools.** Such preventive safety measures reduce the risk of starting the power tool accidentally.
- 4. Store idle power tools out of the reach of children and do not allow persons unfamiliar with the power tool or these instructions to operate the power tool.** Power tools are dangerous in the hands of untrained users.
- 5. Maintain power tools. Check for misalignment or binding of moving parts, breakage of parts and any other condition that may affect the power tool's operation.** If damaged, have the power tool repaired before use. Many accidents are caused by poorly maintained power tools.
- 6. Keep cutting tools sharp and clean.** Properly

maintained cutting tools with sharp cutting edges are less likely to bind and are easier to control.

- 7. Use the power tool, accessories and tool bits etc.** in accordance with these instructions, taking into account the working conditions and the work to be performed. Use of the power tool for operations different from those intended could result in a hazardous situation.

### Service

- 1. Have your power tools serviced by a qualified repair person using only identical replacement parts.** This will ensure that safety of the power tool is maintained.

### Chain saw safety warnings

- 1. Keep all parts of the body away from the saw chain when the chain saw is operating.** Before you start the chain saw, make sure the saw chain is not contacting anything. A moment of inattention while operating chain saws may cause entanglement of your clothing or body with the saw chain.
- 2. Always hold the chain saw with your right hand on the rear handle and your left hand on the front handle.** Holding the chain saw with a reversed hand configuration increases the risk of personal injury and should never be done.
- 3. Hold the power tool by insulated gripping surfaces only, because the saw chain may contact hidden wiring or its own cord.** Saw chains contacting a "live" wire may make exposed metal parts of the power tool "live" and could give the operator an electric shock.
- 4. Wear safety glasses and hearing protection. Further protective equipment for head, hands, legs and feet is recommended.** Adequate protective clothing will reduce personal injury by flying debris or accidental contact with the saw

- chain.
5. **Do not operate a chain saw in a tree.** Operation of a chain saw while up in a tree may result in personal injury.
  6. **Always keep proper footing and operate the chain saw only when standing on fixed, secure and level surface.** Slippery or unstable surfaces such as ladders may cause a loss of balance or control of the chain saw.
  7. **When cutting a limb that is under tension be alert for spring back.** When the tension in the wood fibres is released the spring loaded limb may strike the operator and/or throw the chain saw out of control.
  8. **Use extreme caution when cutting brush and saplings.** The slender material may catch the saw chain and be whipped toward you or pull you off balance.
  9. **Carry the chain saw by the front handle with the chain saw switched off and away from your body.** When transporting or storing the chain saw always fit the guide bar cover. Proper handling of the chain saw will reduce the likelihood of accidental contact with the moving saw chain.
  10. **Follow instructions for lubricating, chain tensioning and changing accessories.** Improperly tensioned or lubricated chain may either break or increase the chance for kickback.
  11. **Keep handles dry, clean, and free from oil and grease.** Greasy, oily handles are slippery causing loss of control.
  12. **Cut wood only. Do not use chain saw for purposes not intended.** For example: do not use chain saw for cutting plastic, masonry or non-wood building materials. Use of the chain saw for operations different than intended could result in a hazardous situation.

**Causes and operator prevention of kickback:**

Kickback may occur when the nose or tip of the guide bar touches an object, or when the wood closes in and pinches the saw chain in the cut. Tip contact in some cases may cause a sudden reverse reaction, kicking the guide bar up and back towards the operator.

Pinching the saw chain along the top of the guide bar may push the guide bar rapidly back towards the operator.

Either of these reactions may cause you to lose control of the saw which could result in serious personal injury. Do not rely exclusively upon the safety devices built into your saw. As a chain saw user, you should take several steps to keep your cutting jobs free from accident or injury.

Kickback is the result of tool misuse and/or incorrect operating procedures or conditions and can be avoided by taking proper precautions as given below:

- 1. Maintain a firm grip, with thumbs and fingers encircling the chain saw handles, with both hands on the saw and position your body and arm to allow you to resist kickback forces.** Kickback forces can be controlled by the operator, if proper precautions are taken. Do not let go of the chain saw.
- 2. Do not overreach and do not cut above shoulder height.** This helps prevent unintended tip contact and enables better control of the chain saw in unexpected situations.
- 3. Only use replacement bars and chains specified by the manufacturer.** Incorrect replacement bars and chains may cause chain breakage and/or kickback.
- 4. Follow the manufacturer's sharpening and maintenance instructions for the saw chain.** Decreasing the depth gauge height can lead to increased kickback.



### **Additional safety warnings**

1. The product should be supplied via a residual current device (RCD) with a tripping current of not more than 30 mA.
2. Position the cord so that it will not be caught on branches and the like, during cutting.
3. It is recommended that first-time user should, as a minimum practice, cutting logs on a saw-horse or cradle.

### **Clothing and protective equipment**

1. Do secure long hair so that it is above shoulder level.
2. Do not wear loose fitting clothing or jewellery as this could be drawn into the engine, catch the chain or undergrowth.
3. Use the following safety clothing and protective equipment when operating the product:
  - Helmet with visor and neck guard - (EN397 compliant),
  - Hearing protectors,
  - Breathing mask,
  - Gloves with approved saw protection (compliant to EN 381-4, EN 381-7, EN420:1, EN 388 Class 0),
  - Protective leggings with approved saw protection (compliant to EN 381-5, EN 340 Class 1),
  - Steel toe cap boots with approved saw protection (compliant to EN 345-2 Class 2),
  - First Aid kit in case of injury.

### **Vibration and noise reduction**

**To reduce the impact of noise and vibration emission, limit the time of operation, use low-vibration and low-noise operating modes as well as wear personal protective equipment.**

Take the following points into account to minimise the vibration and noise exposure risks:

1. Only use the product as intended by its design and these instructions.
2. Ensure that the product is in good condition and well maintained.
3. Use correct cutting attachments for the product and ensure they are in good condition.
4. Keep tight grip on the handles/grip surface.
5. Maintain this product in accordance with these instructions and keep it well lubricated (where appropriate).
6. Plan your work schedule to spread any high vibration tool use across a longer period of time.

### Emergency

Familiarise yourself with the use of this product by means of this instruction manual. Memorise the safety directions and follow them to the letter. This will help to prevent risks and hazards.

- 1. Always be alert when using this product, so that you can recognise and handle risks early.** Fast intervention can prevent serious injury and damage to property.
- 2. Switch off and disconnect from the power supply if there are malfunctions.** Have the product checked by a qualified professional and repaired, if necessary, before you operate it again.

### Residual risks

Even if you are operating this product in accordance with all the safety requirements, potential risks of injury and damage remain. The following dangers can arise in connection with the structure and design of this product:

1. Health defects resulting from vibration emission if the product is being used over long periods of time or not adequately managed and properly maintained.
2. Injuries and damage to property due to broken

cutting attachments or the sudden impact of hidden objects during use.

3. Danger of injury and property damage caused by flying objects.
4. Injuries and damage to property to due to thrown and fallen objects.
5. Prolonged use of this product expose the operator to vibrations and may produce 'whitefinger' disease. In order to reduce the risk, please wear gloves and keep your hands warm. If any of the 'whitefinger' symptoms appear, seek medical advice immediately. 'Whitefinger' symptoms include: numbness, loss of feeling, tingling, pricking, pain, loss of strength, changes in skin colour or condition. These symptoms normally appear in the fingers, hands or wrists. The risk increases at low temperatures.



**WARNING!** This product produces an electromagnetic field during operation! This field may under some circumstances interfere with active or passive medical implants! To reduce the risk of serious or fatal injury, we recommend persons with medical implants to consult their doctor and the medical implant manufacturer before operating this product!

## Symbols

On the product, the rating label and within these instructions you will find among others the following symbols and abbreviations. Familiarize yourself with them to reduce hazards like personal injuries and damage to property.

<b>V~</b>	Volt, (alternating voltage)
<b>Hz</b>	Hertz
<b>W</b>	Watt
<b>/min or min<sup>-1</sup></b>	Per minute
<b>mm</b>	Millimetre
<b>kg</b>	Kilogram
<b>dB(A)</b>	Decibel (A-rated)
<b>m/s<sup>2</sup></b>	Metres per second squared
<b>IPX4</b>	Protection against splashing water from all directions
<b>yyWxx</b>	Manufacturing date code; year of manufacturing (20yy) and week of manufacturing (Wxx)



Lock / to tighten or secure.



Unlock / to loosen.



Note / Remark.



Caution / Warning.



Read the instruction manual.



Wear hearing protection.



Wear eye protection.



Wear respiratory protection.

## Symbols



Wear protective gloves.



Wear protective, slip-resistant footwear.



Wear safety helmet!



Wear face protection!



Switch the product off and disconnect it from the power supply before assembly, cleaning, adjustments, maintenance, storage and transportation.



Remove plug from the mains immediately if the cable is damaged or cut.



Tip contact may cause the guide bar to move suddenly upward and backwards what may cause serious injury to user.



Contact of the guide bar tip with any object should be avoided.



Always use the product with two hands. Do not use one handed when operating the product.



Oil tank for chain oil.



Saw chain tensioning.

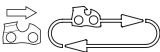

Correct direction of cutting-teeth.



Do not expose the product to rain or wet conditions.

## Symbols



Objects thrown by the product could hit the user or other bystanders. Always ensure that other people and pets remain at a safe distance from the product when it is in operation. In general, children must not come near the area where the product is.



Guaranteed sound power level value in 107dB.



This product is of protection class II. That means it is equipped with enhanced or double insulation.



The product complies with the applicable European directives and an evaluation method of conformity for these directives was done.



This product complies with conformity requirements of the applicable UK Regulations.



WEEE symbol. Waste electrical products should not be disposed of with household waste. Please recycle where facilities exist. Check with your Local Authority or local store for recycling advice.

MCSWP2400S-2: M-Mac Allister, CS-Chain Saw, WP-With Power

## Your product

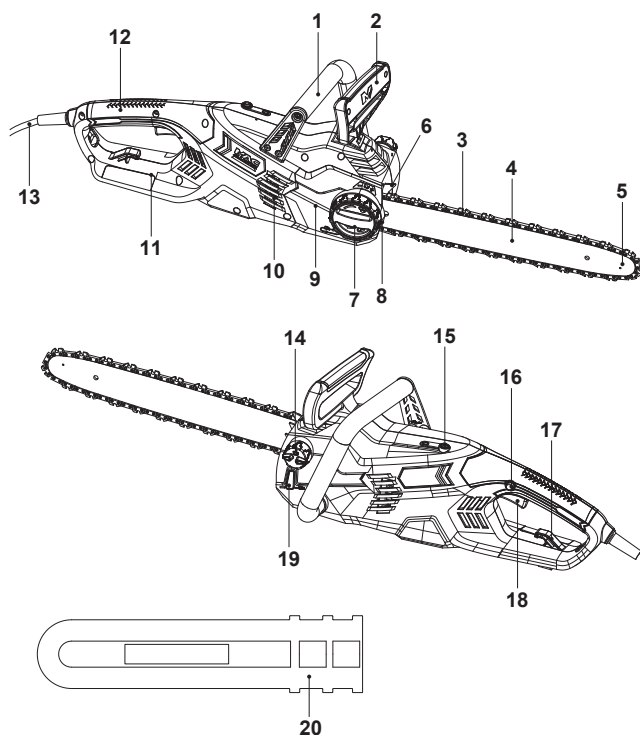

- |                            |                                      |
|----------------------------|--------------------------------------|
| 1. Front handle            | 14. Oil tank cap                     |
| 2. Front guard/chain brake | 15. Reset button for circuit breaker |
| 3. Saw chain               | 16. Lock-off button                  |
| 4. Guide bar               | 17. Cable strain relief              |
| 5. Sprocket wheel          | 18. On/off switch                    |
| 6. Spike bumper            | 19. Oil level window                 |
| 7. Locking wheel           | 20. Guide bar cover                  |
| 8. Tension wheel           | 21. Oiling port*                     |
| 9. Cover                   | 22. Support pin*                     |
| 10. Air vents              | 23. Drive sprocket*                  |
| 11. Rear guard             | 24. Tension disc*                    |
| 12. Rear handle            |                                      |
| 13. Power cord with plug   |                                      |



NOTE: Parts marked with \* are not shown in this overview. Please refer to the respective section in the instruction manual.

Getting started...

## Unpacking

1. Unpack all parts and lay them on a flat, stable surface.
2. Remove all packing materials and shipping devices, if applicable.
3. Make sure the delivery contents are complete and free of any damage. If you find that parts are missing or show damage do not use the product but contact your dealer. Using an incomplete or damaged product represents a hazard to people and property.
4. Ensure that you have all the accessories and tools needed for assembly and operation. This also includes suitable personal protective equipment.



**WARNING!** The product and the packaging are not children's toys! Children must not play with plastic bags, sheets and small parts! There is a danger of choking and suffocation!

## You will need

(items not supplied)

suitable personal protective equipment  
saw chain oil  
funnel

(items supplied)

saw chain(3)  
guide bar (4)  
guide bar cover(20)

## Assembly



**WARNING!** The product must be fully assembled before operation! Do not use a product that is only partly assembled or assembled with damaged parts!



Follow the assembly instructions step-by-step and use the pictures provided as a visual guide to easily assemble the product!



Do not connect the product to power supply before it is completely assembled!  
Always wear gloves during assembly!



Assemble the guide bar and saw chain before operation.

### Chain and guide bar

Use only the guide bar (4) and saw chain (3) according to the technical data of the product.



**WARNING!** Always use a saw chain designed as “low-kickback” or a saw chain which meets the low-kickback requirements! A standard saw chain (a chain which does not have the kickback reducing guard links) should only be used by an experienced professional operator! Nevertheless, a low-kickback saw chain does not completely eliminated kickback! A low-kickback or “safety” chain should never be regarded as complete protection against injury! Therefore always use a low-kickback saw chain in conjunction with other kickback protection devices such as the front guard/chain brake!

1. Place the product on a suitable flat surface.
2. Loosen the cover (9) by turning the locking wheel (7) anticlockwise (Fig. 1, a) and remove it.

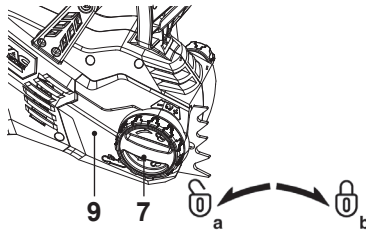

Fig. 1

3. Place the product with drive sprocket (23) facing upwards.
4. Spread the saw chain (3) out with the cutting edges of the chain pointing in the rotational direction and slide the chain into the groove around the guide bar (4) (Fig. 2).

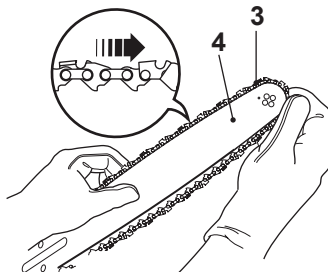

Fig. 2

5. Ensure the tension disc (24) is adjusted to inner right position, turn anticlockwise if required (Fig. 3, 4).

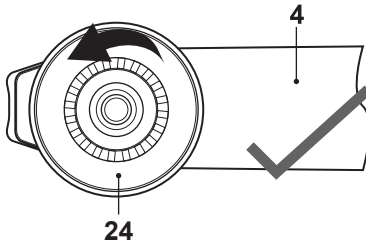

Fig. 3

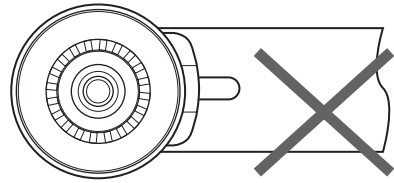

Fig. 4

6. Align the guide bar (4) and saw chain (3) assembly with the drive sprocket (23) and support pin (22). Lay the saw chain around the drive sprocket and then lower the guide bar to install it to the support pin (Figs. 5, 6).
7. Make sure the saw chain (3) is properly placed into the groove around the guide bar (4) before replacing the cover.

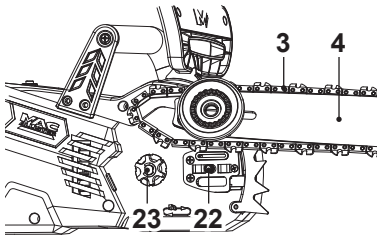

Fig. 5

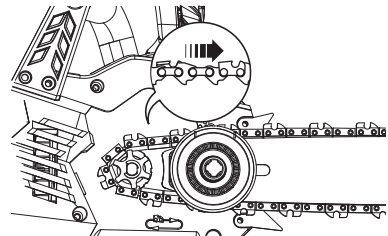

Fig. 6

8. Replace the cover (9) and slightly tighten the locking wheel (7) (Fig. 7, b). Do not tighten the locking wheel (7) completely; saw chain tensioning is required first.

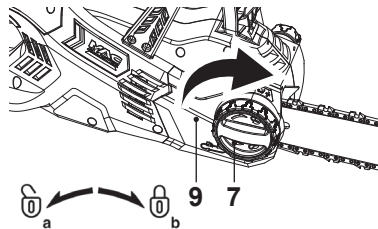

Fig. 7



**NOTE:** The saw chain (3) has not yet been tensioned. Tension the chain as described under "Saw chain tensioning". After operating the product for approx. 1 hour, adjust the chain tension again.

## Saw chain tensioning

Always check the saw chain tension before use, after first cuts and regularly during use, approx. every five cuts. After initial operation, new chains can lengthen considerably. This is normal during the break-in period and the interval between future adjustments will lengthen quickly.



**WARNING!** Unplug the product from the power source before adjusting the saw chain tension!



The cutting edges of the saw chain are sharp. Always wear protective gloves when handling the chain!



Always maintain proper chain tension! A loose chain increases the risk of kickback! A loose chain may jump out of the guide bar groove! This may injure the operator and damage the chain! A loose chain will cause rapid wear to the chain, guide bar and sprocket!

Tensioning the chain too tightly will overload the motor and cause damage, and insufficient tension can cause chain derailing, whereas a correctly tightened chain provides the best cutting characteristics and prolonged working life! The chain life mainly depends upon sufficient lubrication and correct tensioning!

1. Set the product on a suitable flat surface.
2. Slightly loosen the locking wheel (7).
3. Turn the tension wheel (8) until the chain "tie straps" are just touching the bottom edge of the guide bar(4)(Figs. 8, 9).

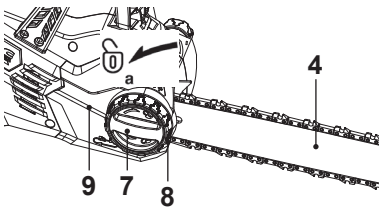

Fig. 8

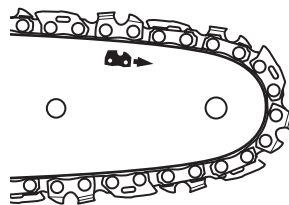

Fig. 9

4. Check the chain tension using one hand to lift the saw chain (3) against the weight of the product. The correct chain tension is achieved when the saw chain can be lifted by approx. 2 - 4 mm from the guide bar (4) in the centre (Fig. 10).

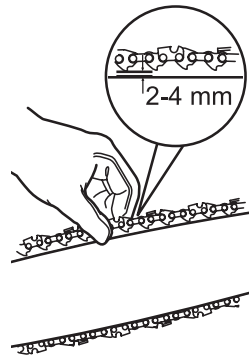

Fig. 10

5. Turn the locking wheel (7) clockwise to tighten the cover (9) completely (Fig. 11).

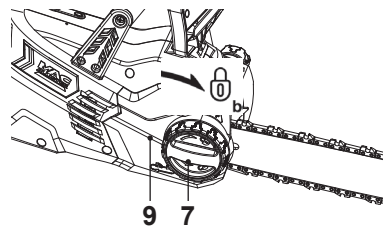

Fig. 11

## Lubrication



**WARNING!** The product is not filled with oil. It is essential to fill the product with oil before using it! Never operate the product without chain oil or with an empty oil tank, as this will result in extensive damage to the product!



Never operate the bar and chain without lubrication oil!



Operating the product dry or with too little oil will decrease cutting efficiency, shorten the product life span and cause rapid wear to the chain and bar from overheating! Insufficient oil is evident by smoke or bar discoloration! Adequate lubrication of the saw chain during cutting operations is essential to minimise friction with the guide bar. Your product is equipped with an automatic oiling system! The oiling system automatically delivers the proper amount of oil to the bar and chain!

1. Set the product on any suitable surface with the oil tank cap (14) facing upwards.
2. Unscrew and remove the oil tank cap (14), then add the lubricant into the tank. We recommend using environmentally-friendly chain oil specifically intended to be used with this product. Use a proper funnel with a filter to prevent debris entering the tank and to avoid spilling and overfilling the tank. Do not overfill and leave approximately 5 mm of space to the lower edge to allow the lubricant to expand (Fig. 12).

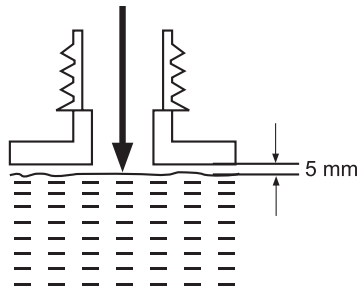

Fig. 12

3. Wipe up spilled lubricant with a soft cloth and refit the oil tank cap (14).



**NOTE:** Always dispose of lubricant, used oil and objects contaminated with them in accordance with local regulations.

4. Check the oil level window (19) prior to start-up and regularly during operation. Refill oil when the oil level is lower than "Min" marking (Fig. 13).

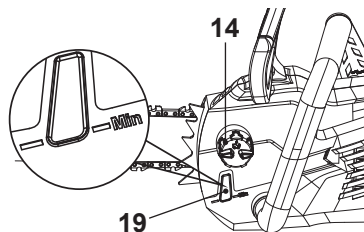

Fig. 13

## Checking



**NOTE:** Perform the following test before operating your product.

This product is equipped with an automatic oiling system. The oiling system automatically delivers the proper amount of oil to the bar and chain.

Checking the lubrication requires starting the product. Before checking, the product must be fully assembled and all instructions must have been read.

1. Check the chain lubrication before each use.
2. Make sure the guide bar (4) and the saw chain (3) are in place when you check the oil delivery.
3. Switch on the product (see section “on/off switch” below); keep pressing the on/off switch (18) and check if the chain oil is delivered as shown in the figure (Fig. 14).

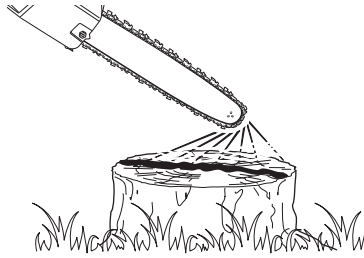

Fig. 14

4. Have the chain oil flow adjusted by an authorised service centre or similar qualified person if required.

## Connection to power supply



**WARNING!** Check the voltage! The voltage must comply with the information on the rating label!

Always use a residual current supply (RCD) with a max. 30 mA release current.

If an extension cord is used, make sure the extension cord is specifically designed for outdoor use and not lighter than H07RN-F, 2x1.5mm<sup>2</sup> and max. 75m.

**For UK only**

1. Make sure the on/off switch (18) is in its off position.
2. Correct the power plug to a suitable power source.
3. Now your product is ready for use.

**Not for UK**

1. Make sure the on/off switch (18) is not pressed.
2. Double the extension cable, about a foot (30cm) from the end, lead the loop through the hole on the rear safe guard and hook the loop over the cable strain relief (17). Gently pull on the cord to ensure that it is firmly attached at the handle (Fig. 15).
3. Connect the plug of the power cord to the socket on the extension cord.
4. Connect the plug of the extension cable to a suitable power source.

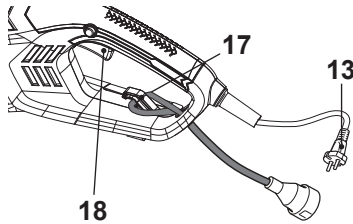

Fig. 15

5. Your product is now ready to be used.

Getting started....





## In more detail...

<b>Product functions</b>	26
<b>Operation</b>	29
<b>Care and maintenance</b>	36
<b>Trouble shooting</b>	42
<b>Recycling and disposal</b>	43
<b>Guarantee</b>	44
Technical <b>specifications</b>	45
<b>EC declaration of conformity</b>	47

In more detail...

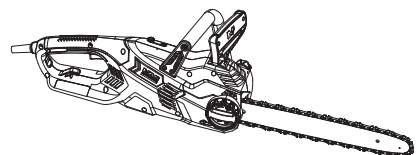

## Intended use

This electric chainsaw MCSWP2400S-2 is designated with a rated input of 2400 Watts.

The product is intended for cutting logs with a thickness of max.400 mm. It must not be used for cutting other materials, such as plastic, stone, metal or wood that contains foreign objects.

The product may only be used with the guide bar/saw chain combination stated in these instructions. It is not permitted to use other types or sizes.

Vertical and horizontal cuts can be performed with this product.

Longitudinal sections can only be cut by professionals.

This product should not be used outside of domestic premises e.g. for cutting firewood in forested areas.

The product should not be used on masonry and materials that are harmful to health.

For safety reasons it is essential to read the entire instruction manual before first operation and to observe all the instructions therein.

This product is intended for private domestic use only, not for any commercial trade use. It must not be used for any purposes other than those described.

## Overload protection

The motor is equipped with an overload protection. When the saw chain is suddenly stalled by extreme over load, the circuit breaker will be activated. When it happens perform the following steps:

- Switch off the machine and disconnect it from the power supply.
- Let the machine cool down for 2-3 minutes, and eliminate the cause of over load before restart the product.
- Press the reset button (15), connect the machine to the power supply
- Restart the machine.

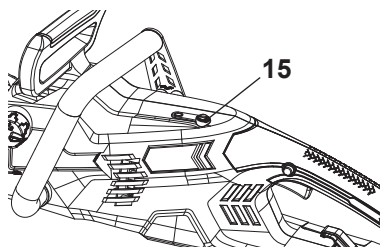

Fig. 16



**NOTE:** The circular breaker can only be activated by sudden over load (i.e. the saw chain is stalled suddenly). Use the machine under heavy load for long time will damage the motor.

## Chain brake

The chain brake is a safety mechanism activated by the front guard (2). When kickback occurs the chain stops immediately.

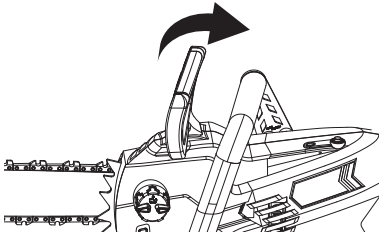

Fig. 17

The chain brake (2) in the disengaged position, the product can be operated (Fig. 17).

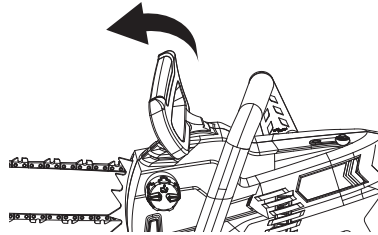

Fig. 18

The chain brake (2) in the engaged position, the saw chain is stopped as soon as the chain brake is activated (Fig. 18).

### Chain brake test



**WARNING!** Before operating this product, always check that the chain brake is in perfect working condition.

The following functional check should be carried out before each use. The purpose of the chain brake test is to reduce the possibility of injury due to kickback.

1. Make sure the chain brake (2) is disengaged. Disengage the chain brake (2) by pulling it back towards the front handle (1)(Fig. 17).
2. Place the product on any suitable flat surface, make sure the saw chain (3) is not touching the surface or other objects and connect it to the power supply as described.
3. Grasp the front handle (1) with your left hand. Your thumb and fingers should encircle the handle. Grasp the rear handle (12) with your right hand. Your thumb and fingers should encircle the handle (Fig. 19).
4. Press the lock-off button (16)



Fig. 19

- with your right thumb, then fully squeeze in the on/off switch (18) with your index finger and hold it in position.
5. While the motor is running, activate the chain brake (2) by moving your left hand forward against the chain brake. The saw chain (3) and motor should stop immediately.



**NOTE:** The motor will not start if the chain brake is in the engaged position.



**WARNING!** If the saw chain and motor fail to stop when the chain brake is engaged, take the product to the nearest authorised dealer or service centre! Do not use the product if the chain brake is not working properly!

The chain brake should not be used for starting and stopping the product during normal operation!

## Switching on/off

1. Make sure the safety chain brake (2) is disengaged (see above Fig. 17).
2. Grip the product with both hands, your left hand holding the front handle (1) (do not hold the chain brake) and your right hand holding the rear handle (12).
3. Press the lock-off button (16) and hold it in position.
4. Squeeze in the on/off switch (18) to switch the product on (Fig. 20).
5. Release the on/off switch (18) to switch the product off.

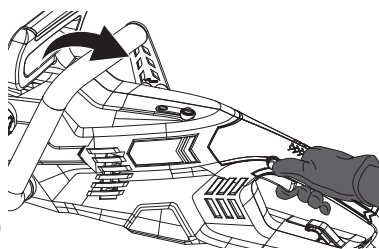

Fig. 20

## General operation

1. Check the product, its power cord and plug as well as accessories for damage before each use. Do not use the product if it is damaged or shows wear.
2. Double check that the accessories and attachments are properly fixed.
3. Always hold the product on its front and rearhandle. Keep the front and rear handle dry to ensure safe support.
4. Ensure that the air vents are always unobstructed and clear. Clean them if necessary with a soft brush. Blocked air vents may lead to overheating and damage the product.
5. Switch the product off immediately if you are disturbed while working by other people entering the working area. Always let the product come to complete stop before putting it down.
6. Do not overwork yourself. Take regular breaks to ensure you can concentrate on the work and have full control over the product.

## Cutting

1. To become proficient attend a recognised chain saw training course to learn how to operate chain saws safely and effectively. Familiarise yourself with all the controls and switches. Practise all movements with the product switched off.
2. Always hold the product firmly with both hands. Hold the front handle with your left hand and the rear handle with your right hand. Fully grip both handles at all times during operation. Never operate the product using only one hand.
3. Ensure the power cord is located to the rear, away from the chain and the wood and is positioned so that it cannot be caught on branches or similar objects during cutting.
4. Only use the product with a secure stance. Hold the product to the right-hand side of your body (Fig. 21).

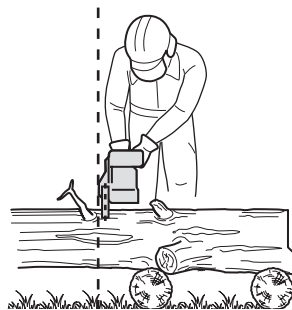

Fig.21

5. The saw chain (3) must be running at full speed before it makes contact with the wood. Use the spike bumper (6) to secure the product onto the wood before starting to cut and use it as a leverage point while cutting (Fig. 22).
6. Reset the spike bumper at a low point when cutting thicker logs by pulling the product slightly backwards until the gripping teeth release, and then reposition at lower level to continue sawing. Do not remove the product completely from the wood.
7. Do not force the saw chain while cutting, let the chain do the work using the gripping teeth to apply minimal leverage pressure.
8. Do not operate the product with your arms fully extended or attempt to saw areas which are difficult to reach, or while on a ladder. Never use the product above shoulder height (Fig. 23).
9. Optimum sawing is achieved if the chain speed remains constant during cutting.
10. Be careful when reaching the end of the cut. The weight of the product may change unexpectedly as it cuts free from the wood. This can cause accidents to the legs and feet. Always remove the product from a wood cut while the product is running.

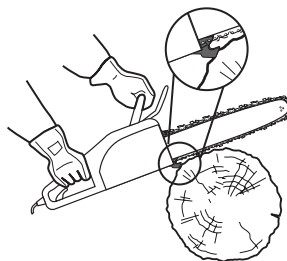

Fig.22

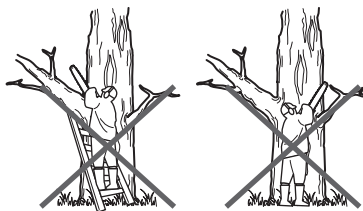

Fig.23



**WARNING!** Switch the product off, let it come to a complete stop and disconnect it from the power supply if the attachment gets stuck in the workpiece. Only then free the jammed attachment.



## Cutting



**WARNING!** Beware of kickback! Kickback can lead to dangerous loss of control of the product and result in serious or fatal injury to the operator or anyone standing close by! Always be alert because rotational kickback and pinch kickback are major product operational dangers and the leading cause of most accidents!



Kickback may occur if the nose or tip of the guide bar touches an object, or if wood pinches the saw chain in the cut. In some cases, contact with the tip of the guide bar (4) may cause a lightning-fast reverse reaction, kicking the guide bar up and back toward the operator (Figs. 24 - 26).

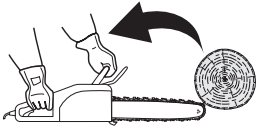

Fig. 24

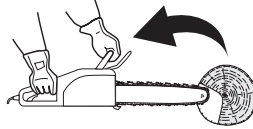

Fig. 25

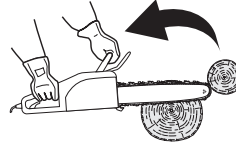

Fig. 26

1. Pinching of the saw chain (3) along the bottom of the guide bar (4) may pull the product forward away from the operator (Fig. 27).
2. Pinching of the saw chain (3) along the top of the guide bar (4) may push the guide bar rapidly back toward the operator (Fig. 28).

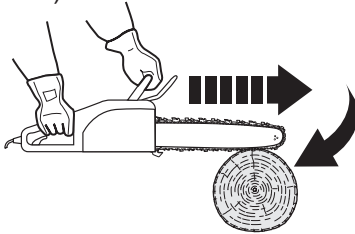

Fig.27

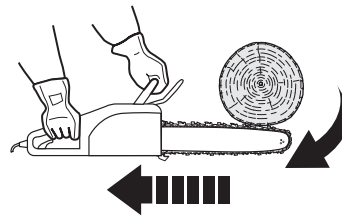

Fig.28

3. Any of these reactions may cause a loss of control over the product, which could result in serious personal injury or even death.
4. With a basic understanding of 'kickback', the element of surprise can be reduced or eliminated. Sudden surprise contributes to the majority of accidents.
5. Keep a good firm grip on the product with both hands, your right hand on the rear handle (12) and your left hand on the front handle (1), when the motor is running. Maintain a firm grip with your thumbs and fingers encircling the handles. A firm grip will help you reduce 'kickback' and maintain control of the product.
6. You should read all the safety warnings and user instructions carefully before attempting to operate this product.

### To avoid kickback

- Saw with the guide bar at a flat angle.
- Never work with a loose, widely stretched or heavily worn chain.
- Ensure the chain is sharpened correctly.
- Never saw above shoulder height.
- Never work with the tip of the guide bar.
- Always hold the product firmly with both hands.

- Always use a low kickback chain.
- Apply the metal gripping teeth for leverage.
- Ensure correct chain tension.

## Felling a Tree

1. When bucking and felling operations are being performed by two or more persons at the same time, the felling operations should be separated from the bucking operation by a distance of at least twice the height of the tree being felled. Trees should not be felled in a manner that would endanger any person, strike any utility line or cause any property damage. If the tree does make contact with any utility line, the company should be notified immediately.
2. The product operator should keep on the uphill side of the terrain as the tree is likely to roll or slide downhill after it is felled.
3. An escape path should be planned and cleared as necessary before cuts are started. The escape path should extend back and diagonally to the rear of the expected line of fall (Fig. 29).
4. Before felling is started, consider the natural lean of the tree, the location of larger branches and the wind direction to judge which way the tree will fall.
5. Remove dirt, stones, loose bark, nails, staples and wire from the tree.

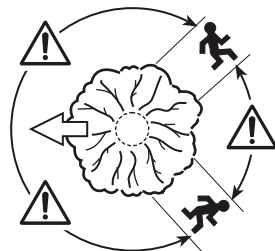

Fig.29

### Notching undercut

Make the notch (Fig. 30, B) 1/3 the diameter of the tree, perpendicular to the direction of falls (Fig. 30). Make the lower horizontal notching cut first. This will help to avoid pinching either the saw chain or the guide bar when the second notch is being made.

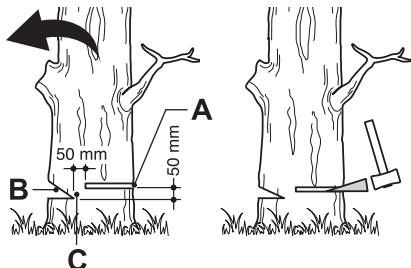

Fig.30



### Felling back cut

1. Make the felling back cut (Fig. 30, A) at least 50 mm higher than the horizontal notching cut (Fig. 30). Keep the felling back cut parallel to the horizontal notching cut. Make the felling back cut so enough wood is left to act as a hinge. The hinge (Fig. 30, C) wood keeps the tree from twisting and falling in the wrong direction. Do not cut through the hinge.
2. As the felling gets close to the hinge, the tree should begin to fall. If there is any chance that the tree may not fall in desired direction or it may rock back and bind the saw chain, stop cutting before the felling back cut is complete and use wedges of wood, plastic or aluminium to open the cut and drop the tree along the desired line of fall.
3. When the tree begins to fall remove the product from the cut, stop the motor, put the product down, then use the retreat path planned. Be alert for overhead limbs falling and watch your footing.

## Limbing and pruning

Limbing is removing the branches from a fallen tree. When limbing leave larger lower limbs to support the log off the ground. Remove the small limbs in one cut (Fig. 31). Branches under tension should be cut from the bottom up to avoid binding the product.

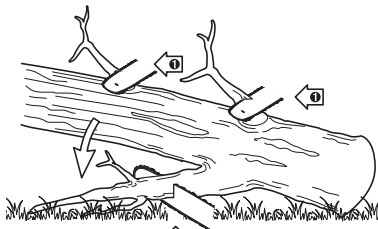

Fig.31



**WARNING!** Never climb into a tree to limb or prune! Do not stand on ladders, platforms, logs, or in any position which may cause you to lose the balance or control of the saw! When pruning trees, it is important not to make the flush cut next to main limb or trunk until you have cut off the limb further out to reduce the weight! This prevents stripping the bark from the main member!



**WARNING!** If the limbs to be pruned are above chest height, hire a professional to perform the pruning!

## Cutting spring poles

A spring pole is any log, branch, rooted stump, or sapling which is bent under tension by other wood so that it springs back if the wood holding it is cut or removed (Fig. 32).

On a fallen tree, a rooted stump has a high potential of springing back to the upright position during the bucking cut to separate the log from the stump.

Watch out for spring poles, they are dangerous.



Fig.32

## Bucking a log

Bucking is cutting a log into lengths. It is important to make sure your footing is firm and your weight is evenly distributed on both feet. When possible, the log should be raised and supported by the use of limbs, logs or chocks.

1. Follow the simple directions for easy cutting. When the log is supported along its entire length (Fig. 33), it is cut from the top (overbuck).
2. When the log is supported on one end (Fig. 34), cut 1/3 the diameter from the underside (underbuck). Then make the finished cut by overbuckling to meet the first cut.

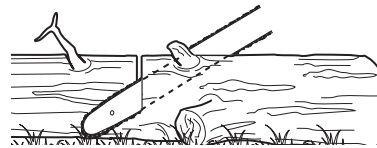

Fig.33

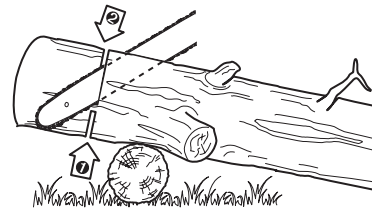

Fig.34

3. When the log is supported on both ends (Fig. 35), cut 1/3 the diameter from the top (overbuck). Then make the finished cut by underbucking the lower 2/3 to meet the first cut.
4. When bucking on a slope always stand on the uphill side of the log (Fig. 36). When "cutting through", to maintain complete control release the cutting pressure near the end of the cut without relaxing your grip on the product handles. Do not let the chain contact the ground. After completing the cut, wait for the saw chain to stop before you move the product. Always stop the engine before moving from tree to tree.
5. Support small logs on a sawing stand or another log while bucking (Fig. 37).
6. If the wood diameter is large enough for you to insert a soft bucking wedge without touching the chain, you should use the wedge to hold the cut open to prevent pinching (Fig. 38).

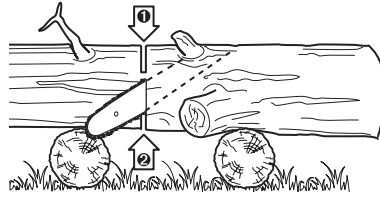

Fig.35



Fig.36

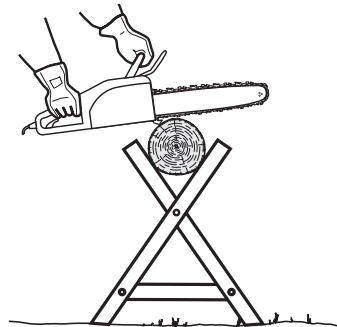

Fig.37

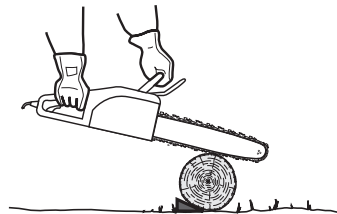

Fig.38

## After use

1. Switch the product off, disconnect it from the power supply and let it cool down.
2. Check, clean and store the product as described below.

## The golden rules for care



**WARNING!** Always switch the product off, disconnect the product from the power supply and let the product cool down before performing inspection, maintenance and cleaning work!



- ① Keep the product clean. Remove debris from it after each use and before storage.
- ② Regular and proper cleaning will help ensure safe use and prolong the life of the product.
- ③ Inspect the product before each use for worn and damaged parts. Do not operate it if you find broken and worn parts.



**WARNING!** Only perform repairs and maintenance work according to these instructions! All further works must be performed by a qualified specialist!

## General cleaning

1. Clean the product with a dry cloth. Use a brush for areas that are hard to reach.
2. In particular clean the air vents(10) after every use with a cloth and brush.
3. Remove stubborn dirt with high pressure air (max. 3 bar).



**NOTE:** Do not use chemical, alkaline, abrasive or other aggressive detergents or disinfectants to clean this product as they might be harmful to its surfaces.

4. Check for worn or damaged parts. Replace worn parts as necessary or contact an authorised service centre for repair before using the product again.

## Maintenance

Before and after each use, check the product and accessories (or attachments) for wear and damage. If required, exchange them for new ones as described in this instruction manual. Observe the technical requirements.

### Sprocket wheel



**NOTE:** It is not necessary to remove the saw chain (3) to lubricate the sprocket wheel(5). Lubrication can be done on the job.

1. Clean the sprocket wheel(5).
2. Using a disposable lubricating gun, insert the nose of the needle into the lubrication hole (D) and inject grease until it appears on the outside edge of the sprocket(Fig. 39).

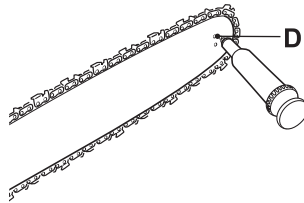

Fig.39

3. Make sure that the chain brake (2) is disengaged. Rotate the saw chain (2) by hand. Repeat the lubrication procedure until the entire sprocket has been greased.

### Guide bar and saw chain

Most guide bar problems can be prevented merely by keeping the product well maintained. Incorrect filing and non-standard cutter and depth gauge settings are the causes of most guide bar problems, primarily resulting in uneven bar wear. As the bar wears unevenly, the rails widen, which may cause the chain to clatter and make it difficult to complete straight cuts. If the guide bar is insufficiently lubricated and the product is operated with a saw chain which is too tight, this will contribute to rapid bar wear. To help minimise bar wear, maintenance of the guide bar as well as the saw chain is recommended.

1. Disassemble the guide bar and saw chain in reversed order from assembly.
2. Check the oiling port (21) for clogging and clean if necessary to ensure proper lubrication of the guide bar and saw chain during operation. Use a soft wire small enough to insert into the oil discharge hole (Fig. 40).

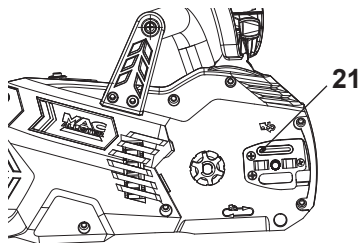

Fig.40



**NOTE:** The condition of the oil passages can be easily checked. If the passages are clear, the chain will automatically give off a spray of oil within seconds of the product starting. Your product is equipped with an automatic oiling system.

3. Check the drive sprocket (23). If it is worn or damaged due to strain, have it replaced by an authorised service agent.
4. Clear residue from the rails on the guide bar (4) using a screwdriver, putty knife, wire brush or other similar tool. This will keep the oil passages open to provide proper lubrication to the guide bar (4) and saw chain (3)(Fig. 41).

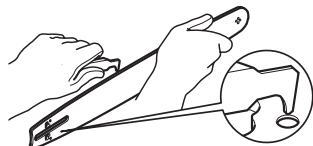

Fig.41

5. Check the guide bar 'rail' for wear: Hold a ruler (straight edge) against the side of the guide bar and 'cutter side plates'. If there is a gap between the ruler and guide bar the guide bar 'rail' is normal. If there is no gap (ruler flush against the side of the guide bar) the guide bar 'rail' is worn and needs to be replaced with a new one of the same type (Fig. 42).
6. Turn the guide bar 180° to allow even wear, thereby extending the life span of the guide bar (4). Loosen the screw and remove the tension disc (24) from the guide bar (Fig. 43). Ensure the rubber washer (a) is free of wear. Turn the guide bar and fix the tension disc with the screw. Apply a drop of suitable glue to the screw to ensure its safe positioning (Fig. 44).

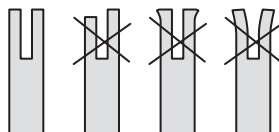

Fig.42

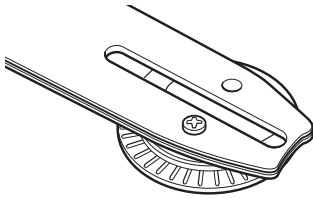

Fig. 43

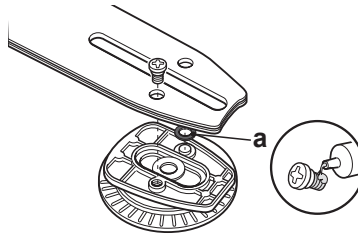

Fig. 44

7. Check the saw chain for possible wear and damages. Replace it with a new one if required. Experienced users can sharpen a dull saw chain (see section “Saw chain sharpening”).
8. Refit the saw chain (3) and the guide bar (4) as described under “Assembly”.

## Spare parts

The following parts of this product may be replaced by the consumer. Spare parts are available at an authorised dealer or through our customer service.

Description	Model no. or Specification
Saw chain	OREGON 91P062X
Guide bar	OREGON 180SDEA041



**NOTE:** Chain must be fitted with bar according to above combination.

## Power cord

If the power cord is damaged, it must be replaced by the manufacturer, its service agent or similarly qualified persons in order to avoid a safety hazard.

## Plug replacement (only for UK market)

If you need to replace the fitted plug, then follow the instructions below.

**IMPORTANT:** The wires in the mains lead are coloured in accordance with the following code:

Blue – Neutral Brown – Live

As the colours of the wire in the mains lead of this product may not correspond with the coloured marking identifying the terminals in your plug, proceed as follows. The wire, which is coloured blue, must be connected to the terminal, which is marked with N or coloured black. The wire, which is coloured brown, must be connected to the terminal, which is marked L or coloured red.

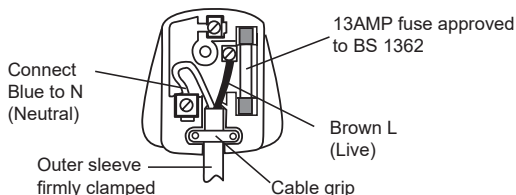

**WARNING!** Never connect live or neutral wires to the earth terminal of the plug, which is marked with E.

Only fit an approved 13 Amp BS 1363 or BS 1363/A plug and the correctly rated fuse. If in doubt, consult a qualified electrician.



**NOTE:** If a moulded plug is fitted and has to be removed take great care in disposing of the plug and severed cable, it must be destroyed to prevent engaging into a socket.

## Repair

This product does not contain any parts that can be repaired by the consumer. Contact an authorised service centre or a similarly qualified person to have it checked and repaired.



## Storage

---

1. Switch the product off and disconnect it from the power supply.
2. Clean the product as described above.
3. Store the product and its accessories in a dark, dry, frost-free, well-ventilated place.
4. Always store the product in a place that is inaccessible to children. The ideal storage temperature is between 10°C and 30°C.
5. We recommend using the original package for storage or covering the product with a suitable cloth or enclosure to protect it against dust.

## Transportation

---

1. Switch the product off and disconnect it from the power supply.
2. The chain cover must be clipped onto the chain and bar as soon as the sawing work has been completed and whenever the machine has to be transported.
3. Always carry the product by its fronthandle(1).
4. Protect the product from any heavy impact or strong vibrations which may occur during transportation in vehicles.
5. Secure the product to prevent it from slipping or falling over.

## Troubleshooting

Suspected malfunctions are often due to causes that the users can fix themselves. Therefore check the product using this section. In most cases the problem can be solved quickly.



**WARNING!** Only perform the steps described within these instructions! All further inspection, maintenance and repair work must be performed by an authorised service centre or a similarly qualified specialist if you cannot solve the problem yourself!

<b>Problem</b>	<b>Possible cause</b>	<b>Solution</b>
1. Product does not start.	1.1. Not connected to power supply. 1.2. Power cord or plug is defective. 1.3. Other electrical defect to the product. 1.4. Overload protection is actuated.	1.1. Connect to power supply. 1.2. Check by a specialist electrician. 1.3. Check by a specialist electrician. 1.4. Switch the product off and let it cool down, press the reset button then restart.
2. Product does not reach full power.	2.1. Extension cord not suitable for operation with this product. 2.2. Power source (e.g. generator) has too low voltage. 2.3. Air vents are blocked.	2.1. Use a proper extension cord. 2.2. Connect to another power source. 2.3. Clean the air vents.
3. Unsatisfactory result.	3.1. Saw chain is not tensioned properly. 3.2. Saw chain is blunt.	3.1. Tension properly. 3.2. Sharpen or replace saw chain.

## Recycling and disposal

---

Waste electrical products should not be disposed of with household waste. Please recycle where facilities exist.

Check with your Local Authority or local store for recycling advice.



## Guarantee

---

- > This product carries a guarantee of 24 months starting from the day of purchase. Please retain your receipt as a proof.
- > This guarantee specifically excludes losses due to:
  - Normal wear and tear, including accessory wear
  - Overload, misuse or neglect
  - Failure of consumable items (such as batteries)
  - Repairs attempted by anyone other than an authorized agent
  - Accidental damage caused by foreign objects or substances
  - Lack of routine maintenance
  - Failure to follow manufacturer's guidelines
  - Loss of use of the goods
- > Due to continuous product improvement, we reserve the right to change the product specification without prior notice.
- > This guarantee does not affect your statutory rights.
- > For any inquiries relating to the guarantee please contact your retailer : If you purchased this product in B&Q store or website then call 0333 0143101. If you bought this product in SFX outlet or website then call 03330 112 112

## Technical specifications

### General

> Rated voltage, frequency	220-240 V~ ,50 Hz
> Rated power input	2400 W
> Rated no load speed $n_0$	8902 $\text{min}^{-1}$
> Protection class	II □
> Weight	approx. 6.8 kg
> Cutting length:	400 mm
> Guide bar length:	450 mm (18")
> Guide bar type:	OREGON 180SDEA041
> Saw chain type:	OREGON 91P062X
> Chain speed:	13.5 m/s
> Volume of oil tank:	110ml
> Chain oil type	SAE #32 in summer and SAE #32 in winter

### Sound values

> Sound pressure level $L_{pA}$	95.69 dB (A)
> Sound power level $L_{WA}$	106.69 dB(A)
> Uncertainty $K_{pA}$ , $K_{WA}$	2.5 dB(A)
> Guaranteed sound power level $L_{WA}$	107 dB(A)

### Hand arm vibration values

> Front handle $a_h$	5.345 $\text{m/s}^2$
> Rear handle $a_h$	5.289 $\text{m/s}^2$
> Uncertainty K	1.5 $\text{m/s}^2$

The sound values have been determined according to noise test code given in EN60745-1, using the basic standards EN ISO 3744 and EN ISO 11203.

The sound intensity level for the operator may exceed 80 dB(A) and ear protection measures are necessary.

The declared vibration value has been measured in accordance with a standard test method (according to EN 60745-1 and EN 60745-2-13) and may be used for comparing one product with another.

The declared vibration value may also be used in a preliminary assessment of exposure.



**WARNING!** Depending on the actual use of the product the vibration values can differ from the declared total. Adopt proper measures to protect yourself against vibration exposures. Take the whole work process including times the product is running under no load or switched off into consideration.

Proper measures include among others regular maintenance and care of the product and accessories, keeping hands warm, periodical breaks and proper planning of work processes.

## Additional information

---

Due to the power absorbed by this product at start-up, voltage drops may occur which may influence other equipment (e.g. by decreasing the light intensity briefly).

Please kindly be informed that if the main impedance is less than 0.353 Ohm These disturbances are not expected.

In case of a problem you can contact your electricity supplier.

## EC declaration of conformity



WE

Kingfisher International Products B.V.  
Rapenburgerstraat 175E 1011 VM Amsterdam  
The Netherlands

Declare that the product  
2400W chain saw MCSWP2400S-2  
Serial number: from 000001 to 999999

Complies with the essential health and safety requirements of the following directives:

The Machinery Directive 2006/42/EC

EN 60745-1:2009+A11:2010

EN 60745-2-13:2009+A1:2010

The EMC Directive 2014/30/EU

EN 55014-1:2006+A1+A2

EN55014-1:2017

EN 55014-2:2015

EN 61000-3-2:2014

EN 61000-3-3:2013

The Outdoor Noise Directive 2000/14/EC & 2005/88/EC

Measured sound power level: 106 dB(A)

Guaranteed sound power level: 107 dB(A)

The conformity assessment followed was according to annex V of the directive

The RoHS Directive 2011/65/EU

Authorised signatory and technical file holder

Eric Capotummino / Group Quality Director

Date:01/09/2020

Kingfisher International Products B.V.  
Rapenburgerstraat 175E 1011 VM Amsterdam  
The Netherlands

In more detail...



**Manufacturer, Fabricant, Producent, Producător, Fabricante:**

UK Manufacturer:  
Kingfisher International Products Limited  
3 Sheldon Square, London, W2 6PX  
United Kingdom  
[www.kingfisher.com/products](http://www.kingfisher.com/products)

EU Manufacturer:  
Kingfisher International Products B.V.  
Rapenburgerstraat 175E  
1011 VM Amsterdam  
The Netherlands  
[www.kingfisher.com/products](http://www.kingfisher.com/products)

EN	<a href="http://www.diy.com">www.diy.com</a> <a href="http://www.screwfix.com">www.screwfix.com</a> <a href="http://www.screwfix.ie">www.screwfix.ie</a>	To view instruction manuals online, visit <a href="http://www.kingfisher.com/products">www.kingfisher.com/products</a>
FR	<a href="http://www.castorama.fr">www.castorama.fr</a> <a href="http://www.bricodepot.com">www.bricodepot.com</a>	Pour consulter les manuels d'instructions en ligne, rendez-vous sur le site <a href="http://www.kingfisher.com/products">www.kingfisher.com/products</a>
PL	<a href="http://www.castorama.pl">www.castorama.pl</a>	Aby zapoznać się z instrukcją obsługi online, odwiedź stronę <a href="http://www.kingfisher.com/products">www.kingfisher.com/products</a>
ES	<a href="http://www.bricodepot.es">www.bricodepot.es</a>	Para consultar los manuales de instrucciones en línea, visite <a href="http://www.kingfisher.com/products">www.kingfisher.com/products</a>
PT	<a href="http://www.bricodepot.pt">www.bricodepot.pt</a>	Para consultar manuais de instruções online, visite <a href="http://www.kingfisher.com/products">www.kingfisher.com/products</a>
RO	<a href="http://www.bricodepot.ro">www.bricodepot.ro</a>	Pentru a consulta manualele de instrucțiuni online, vizitați <a href="http://www.kingfisher.com/products">www.kingfisher.com/products</a>
TR	<a href="http://www.koctas.com.tr">www.koctas.com.tr</a>	Kullanım kılavuzuna internet üzerinden ulaşmak için <a href="http://www.kingfisher.com/products">www.kingfisher.com/products</a> adresini ziyaret edin