

COOKE[™]
& LEWIS

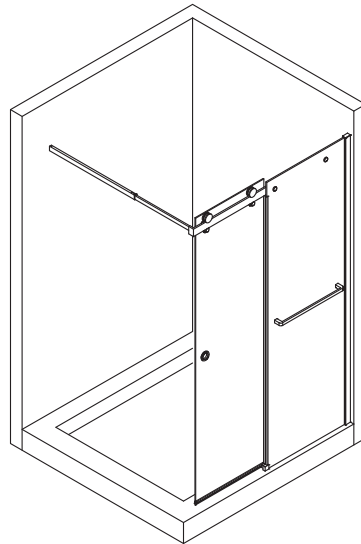
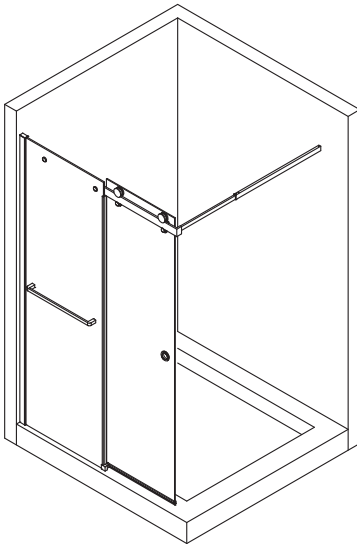

3663602769750
3663602769767
3663602769774

Naya

V11117



EN Preparation FR Préparation PL Przygotowanie
 DE Vorbereitung RUS Подготовка RO Pregătire
 ES Preparación PT Preparação TR Hazırlık

3



EN Product description FR Description du produit PL Opis produktu
 DE Produktbeschreibung RUS Описание продукта RO Descrierea produsului
 ES Descripción del producto PT Descrição do Produto TR Ürün Açıklaması

4



EN Assembly FR Assemblage PL Montaż DE Montage RUS Сборка
 RO Asamblare ES Montaje PT Montagem TR Kurulum

5



EN Care & maintenance FR Entretien et maintenance
 PL Pielęgnacja i konserwacja DE Pflege und Wartung
 RUS Уход и обслуживание RO Îngrijire și întreținere
 ES Cuidados y Mantenimiento PT Cuidados e manutenção
 TR Bakım ve Onarım

EN	20
FR	20
PL	21
DE	21
RUS	22

RO	22
ES	23
PT	23
TR	24



=



+



EN IMPORTANT - Please read carefully the separate safety guide before use.

FR IMPORTANT - Lire attentivement le guide de sécurité séparé avant utilisation.

PL WAŻNE - Przed użyciem proszę dokładnie zapoznać się z instrukcją bezpieczeństwa.

DE WICHTIG - Bitte lesen sie die separaten sicherheitsanweisungen vor gebrauch.

RU ВАЖНО - Пожалуйста, внимательно прочитайте отдельное руководство по технике безопасности перед использованием.

RO IMPORTANT - Vă rugăm să citiți cu atenție ghidul de siguranță separat înainte de utilizare.

ES IMPORTANTE - Lea atentamente la guía de seguridad separado antes de utilizar.

PT IMPORTANTE - Leia atentamente o guia de segurança separado antes de usar.

TR ÖNEMLI - Kullanmadan önce emniyet kurallarını lütfen dikkatle okuyun.

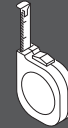
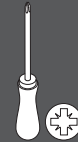
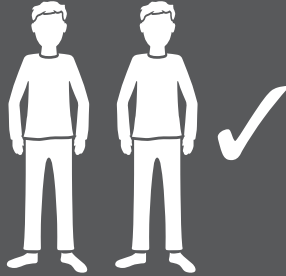

Ø6mm



Ø3.2mm



[01] x1



[02] x1



[03] x5



[05] x3



[06] x3

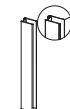

[08] x1

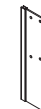

[09] x1



[10] x1

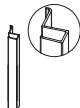

[11] x1

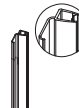

[12] x1



[13a] x1



[13b] x1



[14] x1

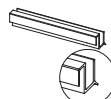

[15] x1



[16] x1



[17] x1



[20] x3



[21] x4



[22] x2



[23] x2

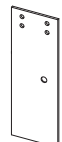

[24] x1



[25] x1



[26] x2

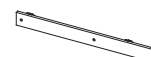

[27] x1

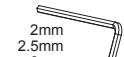

2mm
2.5mm
3mm
4mm
5mm

[28] x1



[04] x4 (ST4 x 30mm)



[07] x3 (ST4 x 6mm)



[18] x1 (ST4 x 40mm)



[19] x1 (M6 x 14mm)



EN Product description

DE Produktbeschreibung

ES Descripción del producto

FR Description du produit

RUS Описание продукта

PT Descrição do Produto

PL Opis produktu

RO Descrierea produsului

TR Ürün Açıklaması

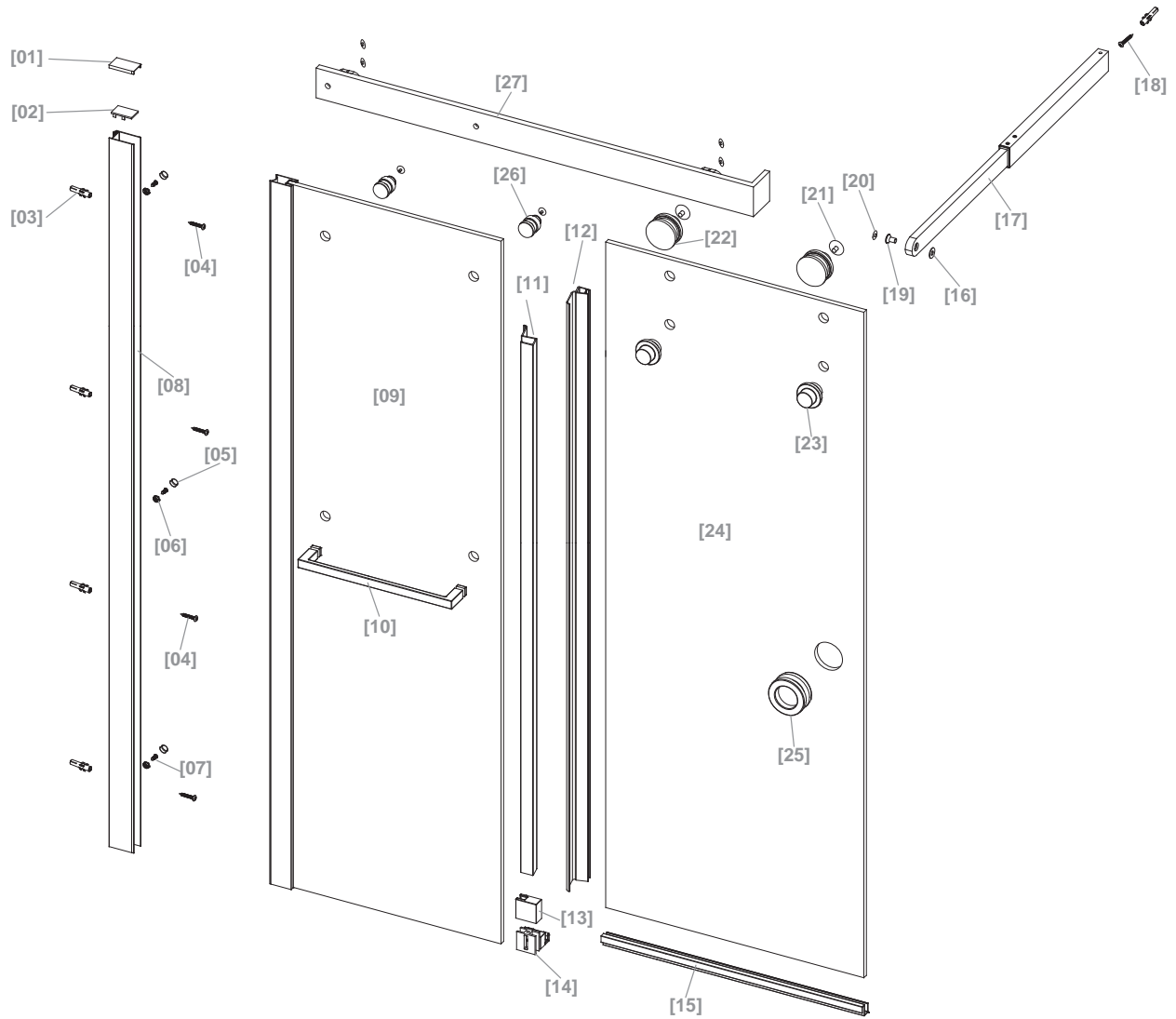



- EN Assembly
- FR Assemblage
- PL Montaż
- DE Montage
- RUS Сборка
- RO Asamblare
- ES Montaje
- PT Montagem
- TR Kurulum

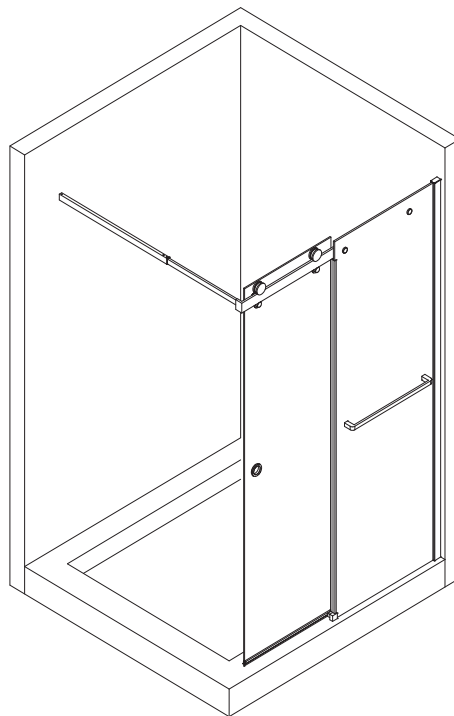
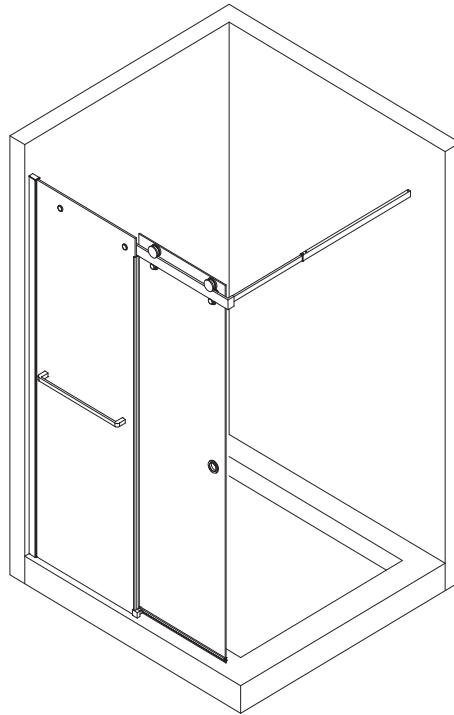

01 **A**



[03] x4



[04] x4 (ST4 x 30mm)

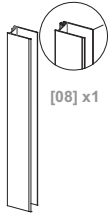

[08] x1

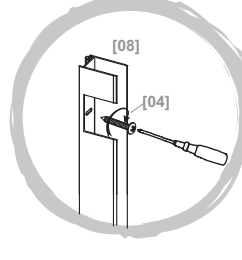
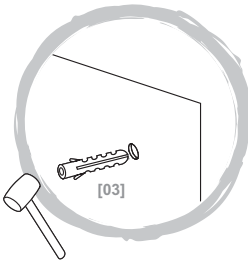
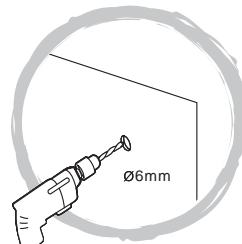
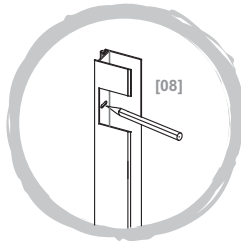
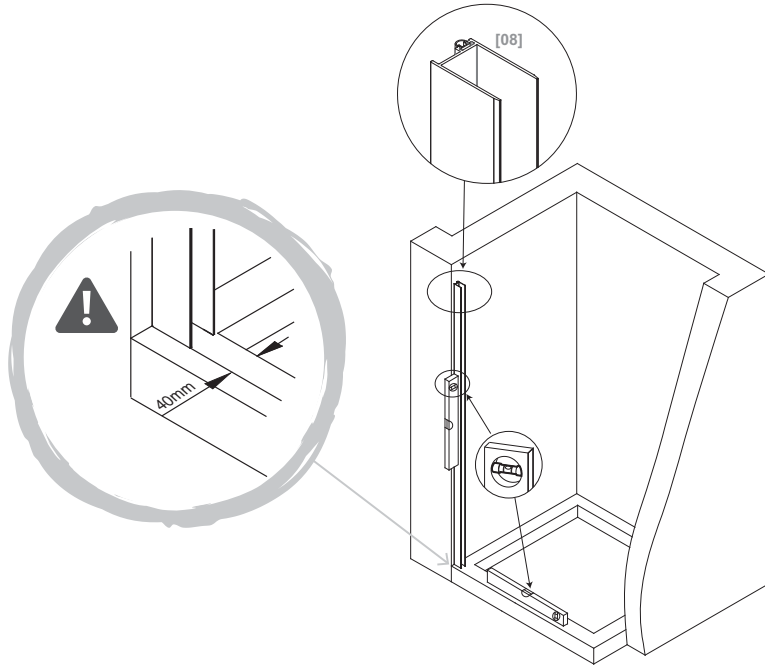

02 A



[09] x1

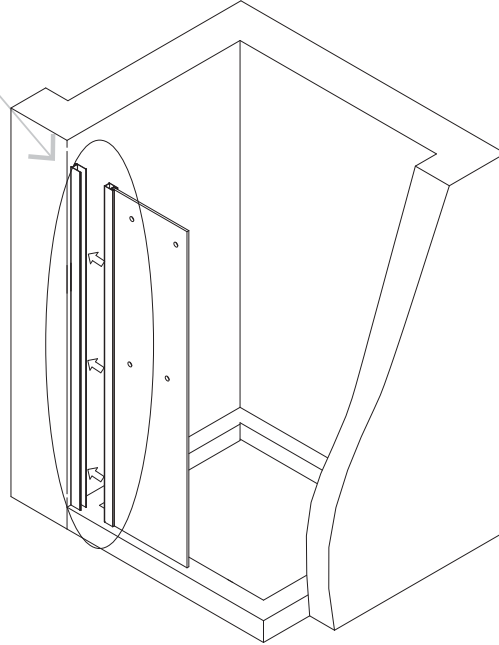
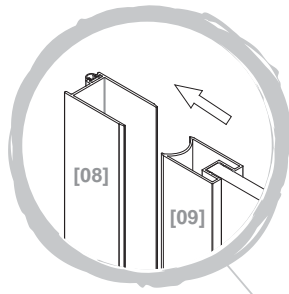

03 A

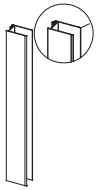

[08] x1



[09] x1



[20] x2



[26] x2

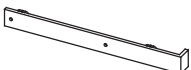





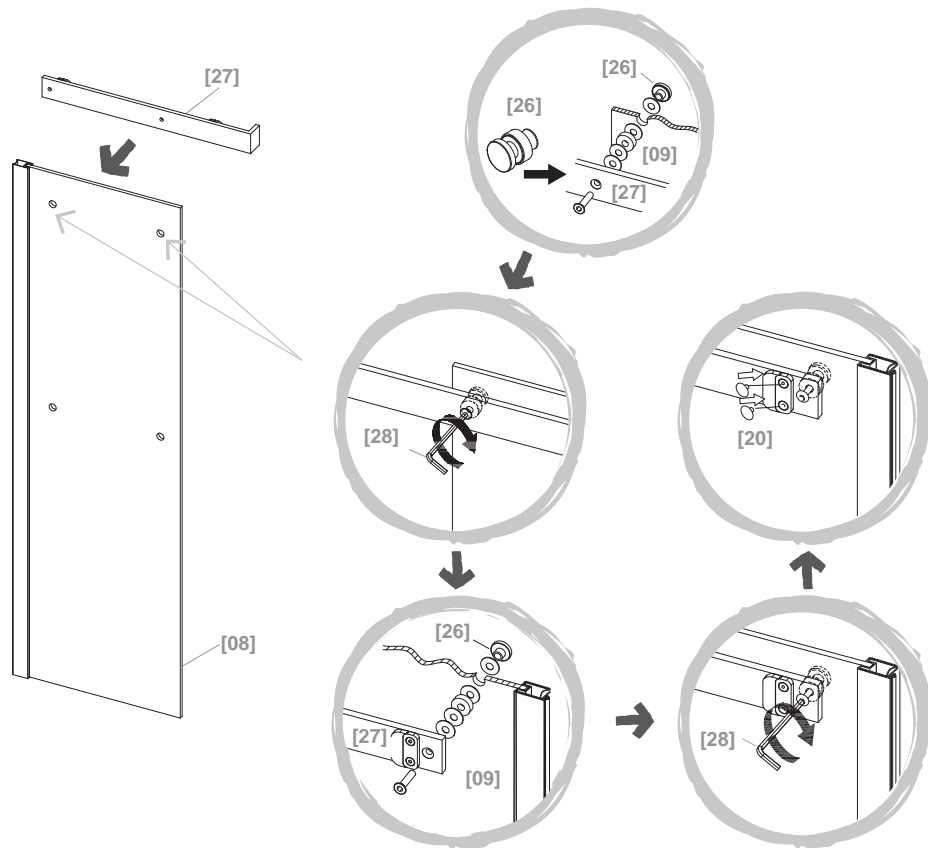

[27] x1



[28] x1
5mm



04 **A**

-  [16] x1
-  [17] x 1
-  [18] x1 (ST4 x 40mm)
-  [19] x1 (M6 x 14mm)
-  [20] x1
-  [03] x1
-  [28] x2
2.5mm
4mm

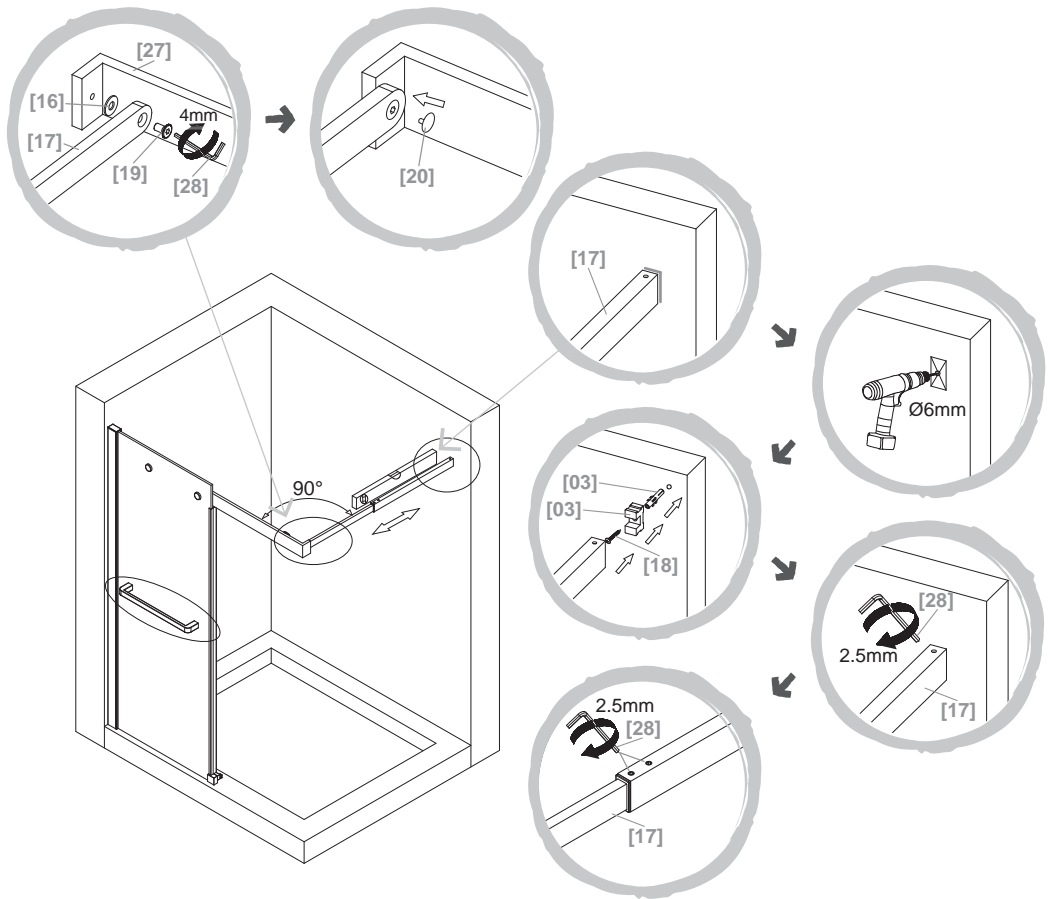

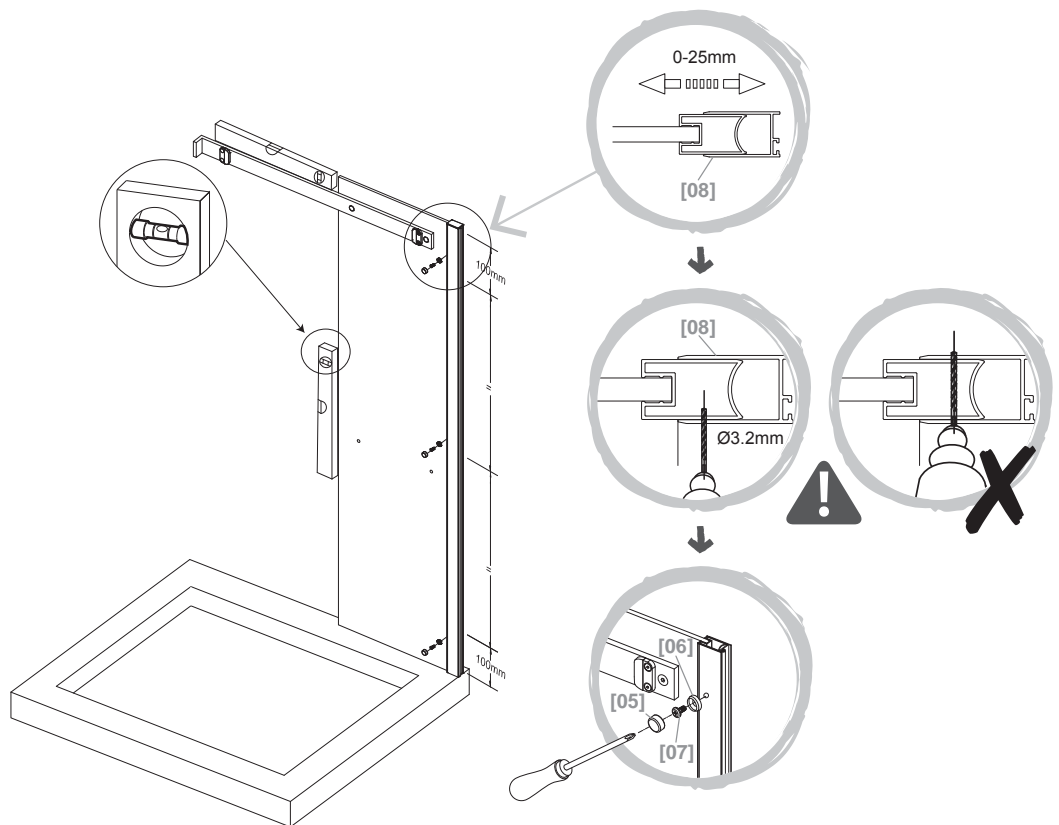

05 **A**

-  [05] x3
-  [06] x3
-  [07] x3 (ST4 x 6mm)

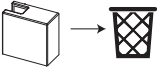

06 A

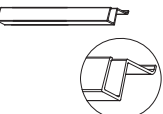
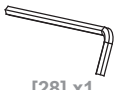
-  [10] x1
-  [13a] x1
-  [13b] x1
-  [14] x1
-  [11] x1
-  [28] x1
2mm

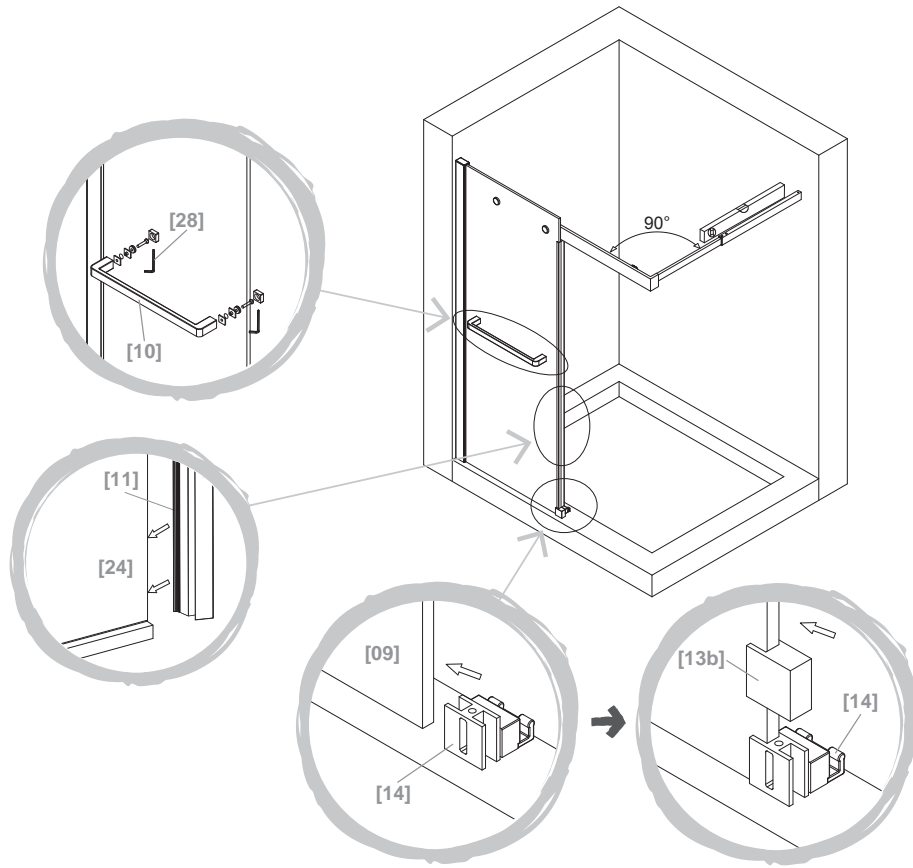

07 A

-  [22] x2
-  [25] x1
-  [15] x1
-  [12] x1
-  [28] x1
5mm

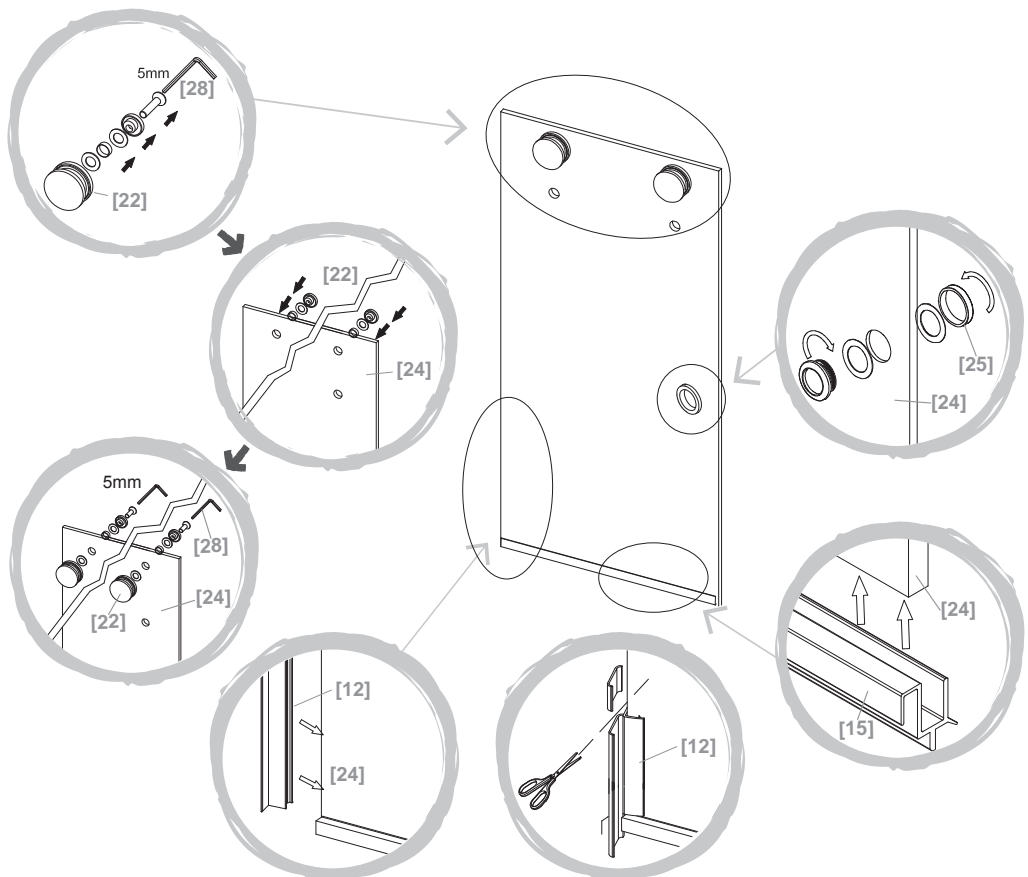

08 A

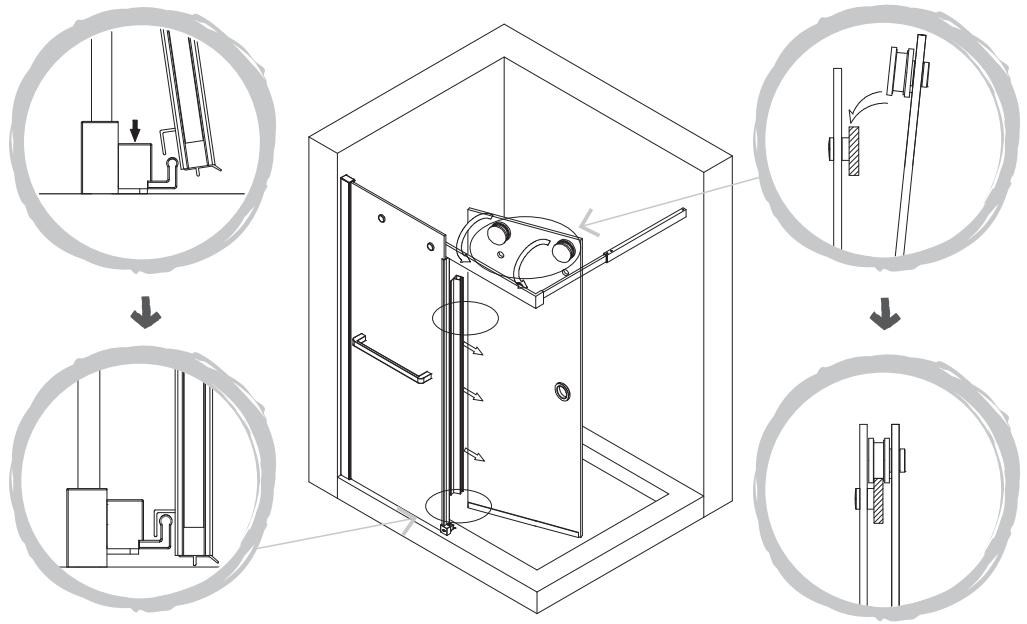

09 A

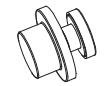

[23] x2



[21] x4



[28] x1
4mm

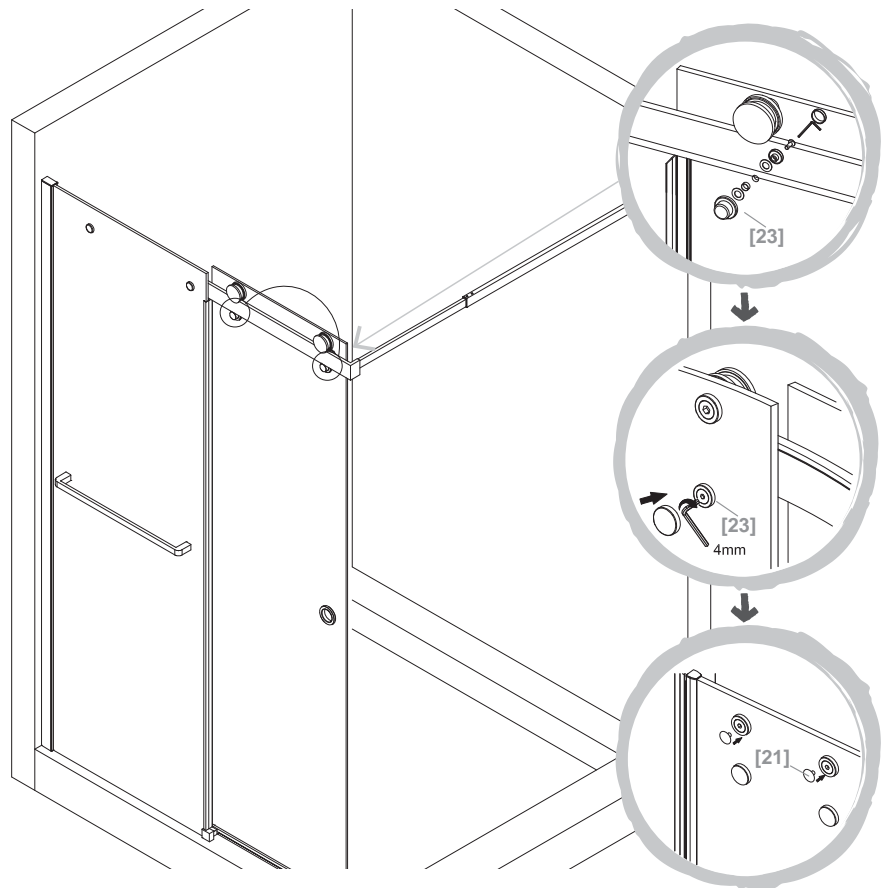

10

A

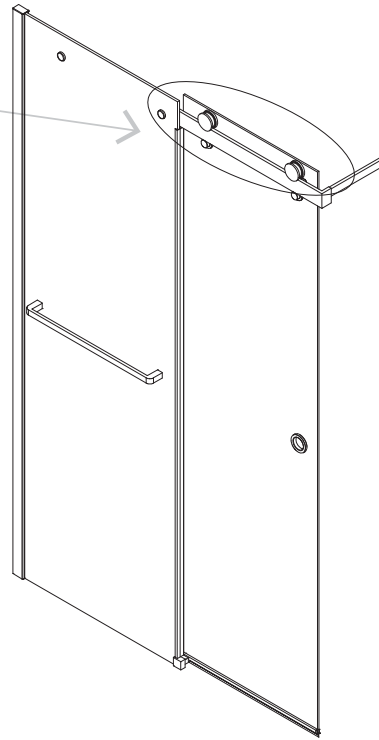
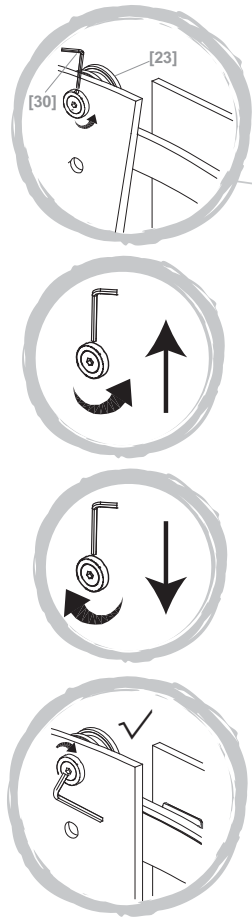

11

A

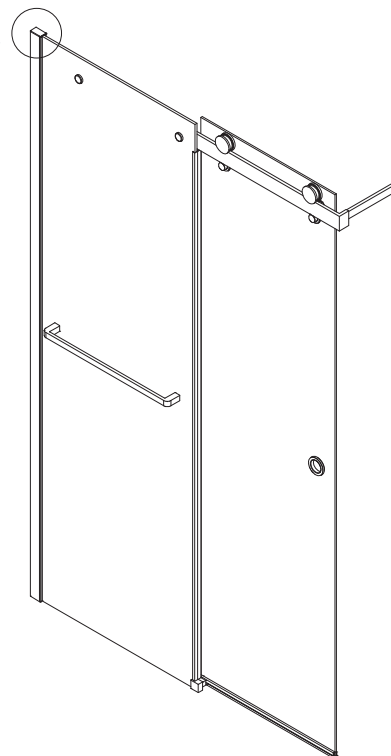
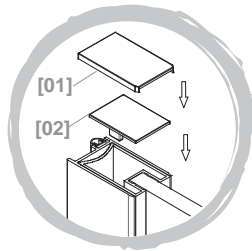

12

A

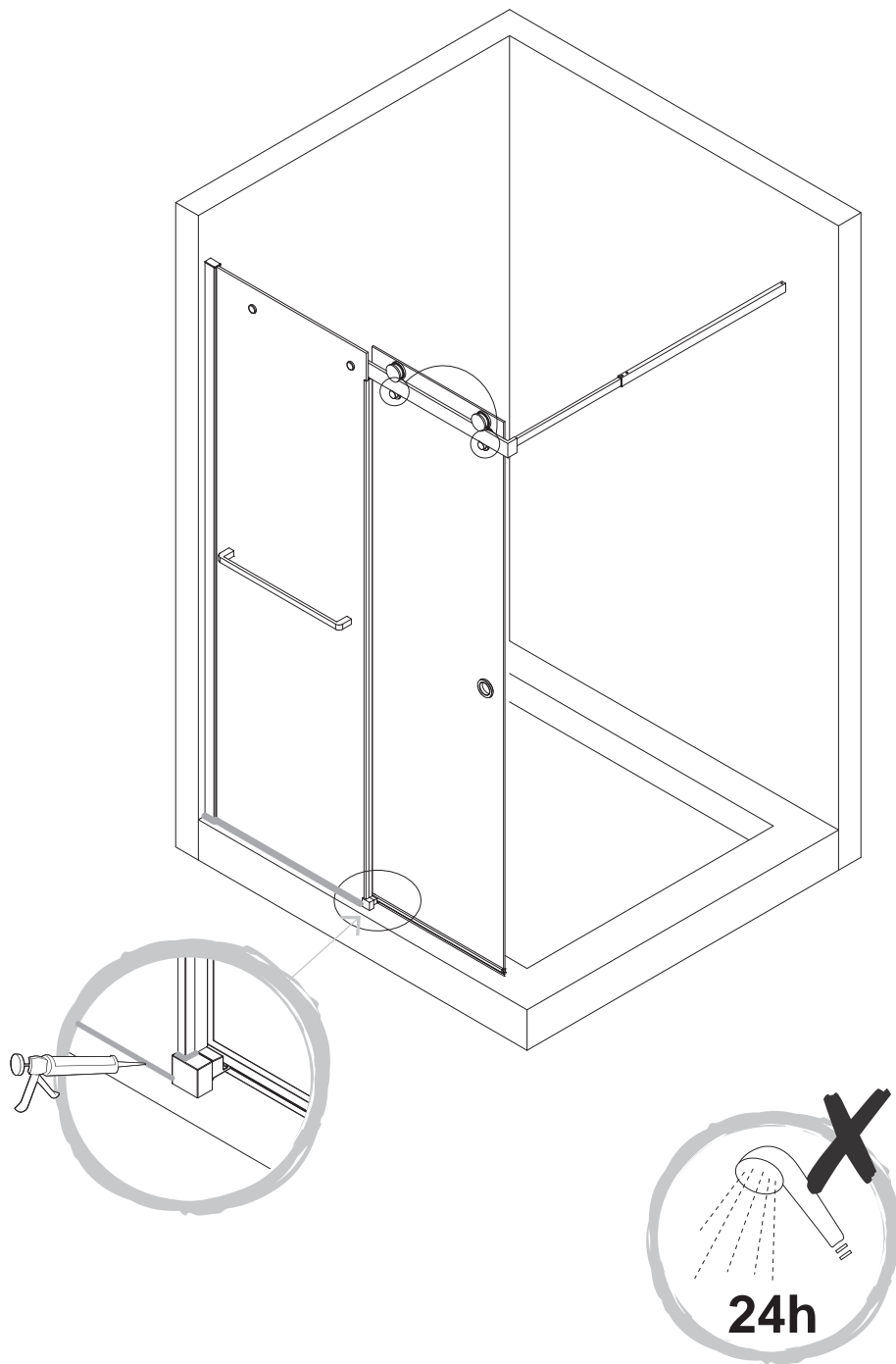

- EN Do not use the shower enclosure for at least 24 hours in order to allow the silicone sealant to cure fully.
- FR N'utilisez pas votre douche pendant au moins 24 heures afin de permettre aux joints de silicone de sécher entièrement.
- PL Po zakończonym montażu, nie używaj brodzika prysznicowego przez co najmniej 24 godziny, aby umożliwić pełne osadzenie się uszczelnacza silikonowego.
- DE Die Duschkabine darf innerhalb von mindestens 24 Stunden nicht benutzt werden, damit die Silikonversiegelung vollständig abbinden kann.
- RUS Для обеспечения полного высыхания силиконового уплотнителя воздержитесь от пользования душевой кабиной на протяжении 24 часов после установки.
- RO Nu utilizați cabina de duș timp de cel puțin 24 de ore pentru a permite izolației de silicon să se usuce complet.
- ES No use la cabina de la ducha por lo menos 24 horas para dejar que el sellador de silicon se fragüe completamente.
- PT Não utilize a divisória de chuveiro durante, no mínimo, 24 horas para garantir que o vedante de silicone fica totalmente seco.
- TR Silikon sızdırmazlık malzemesinin tamamen kurumasına izin vermek için duşakabini en az 24 saat boyunca kullanmayın.

01 **B**

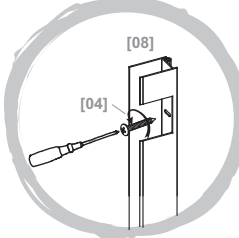
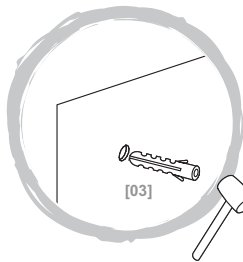
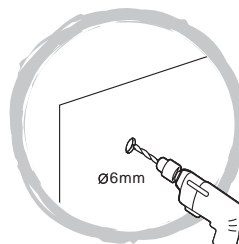
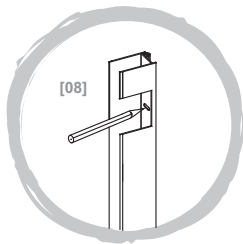
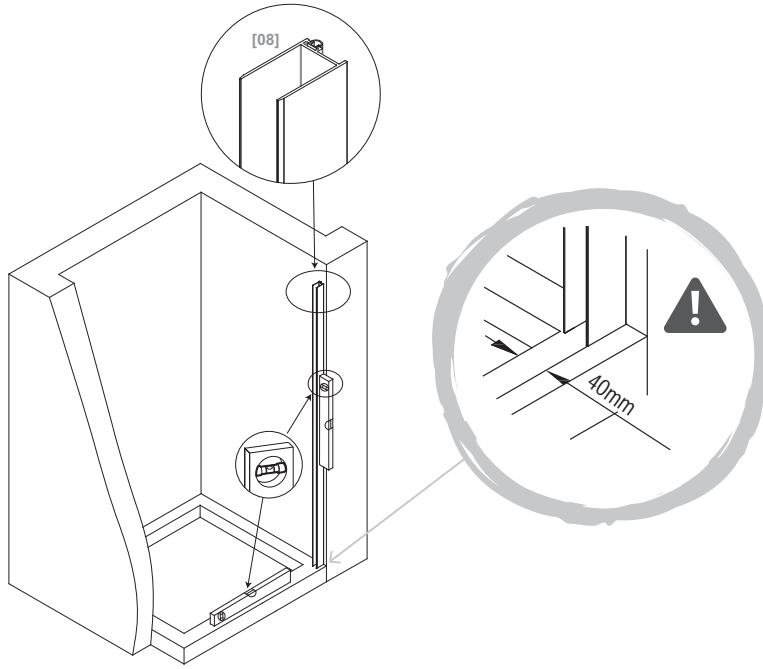
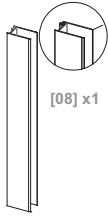

02 B



[09] x1

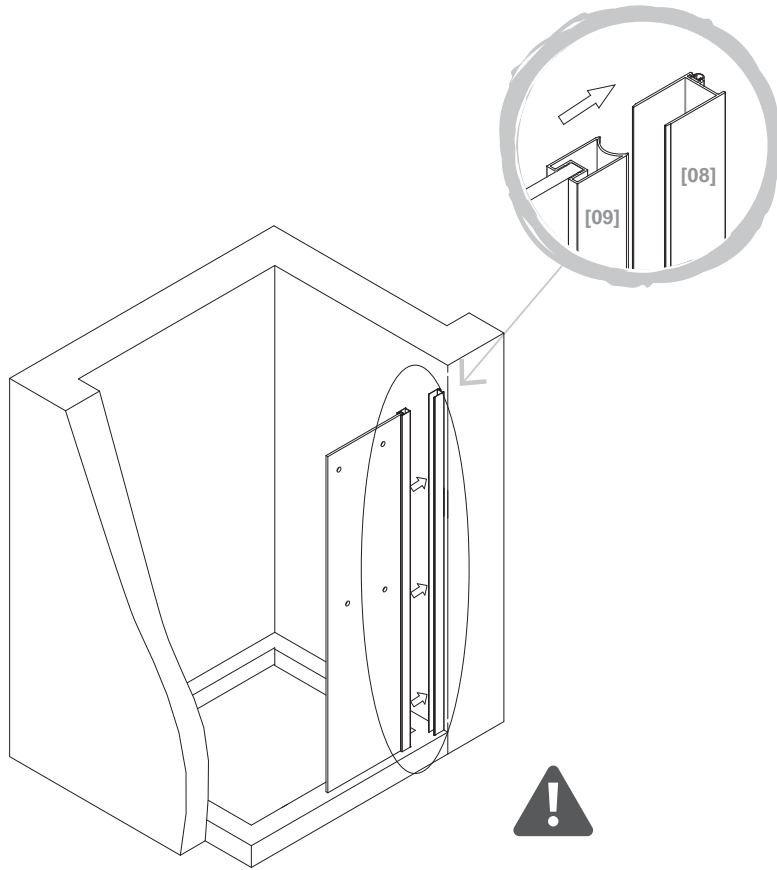

03 B

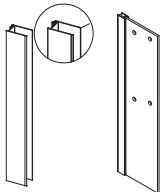

[08] x1 [09] x1



[20] x2



[26] x2

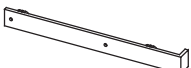





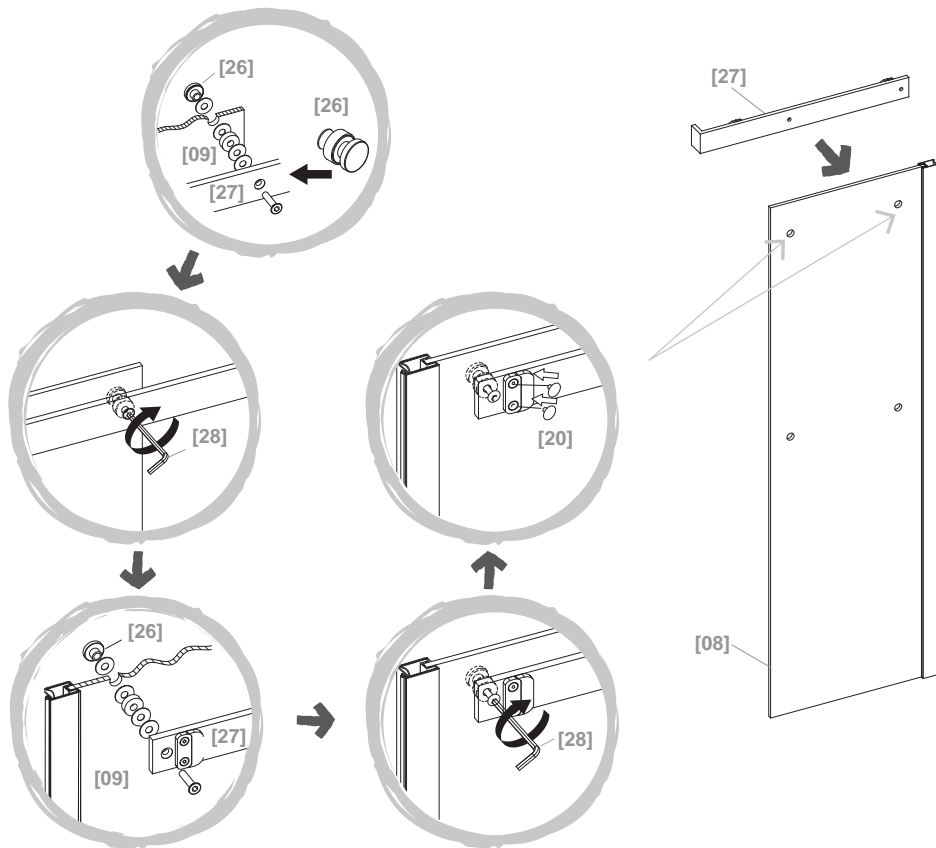

[27] x1



[28] x1
5mm



04 B

-  [16] x1
-  [17] x 1
-  [18] x1 (ST4 x 40mm)
-  [19] x1 (M6 x 14mm)
-  [20] x1
-  [03] x1
-  [28] x2
2.5mm
4mm

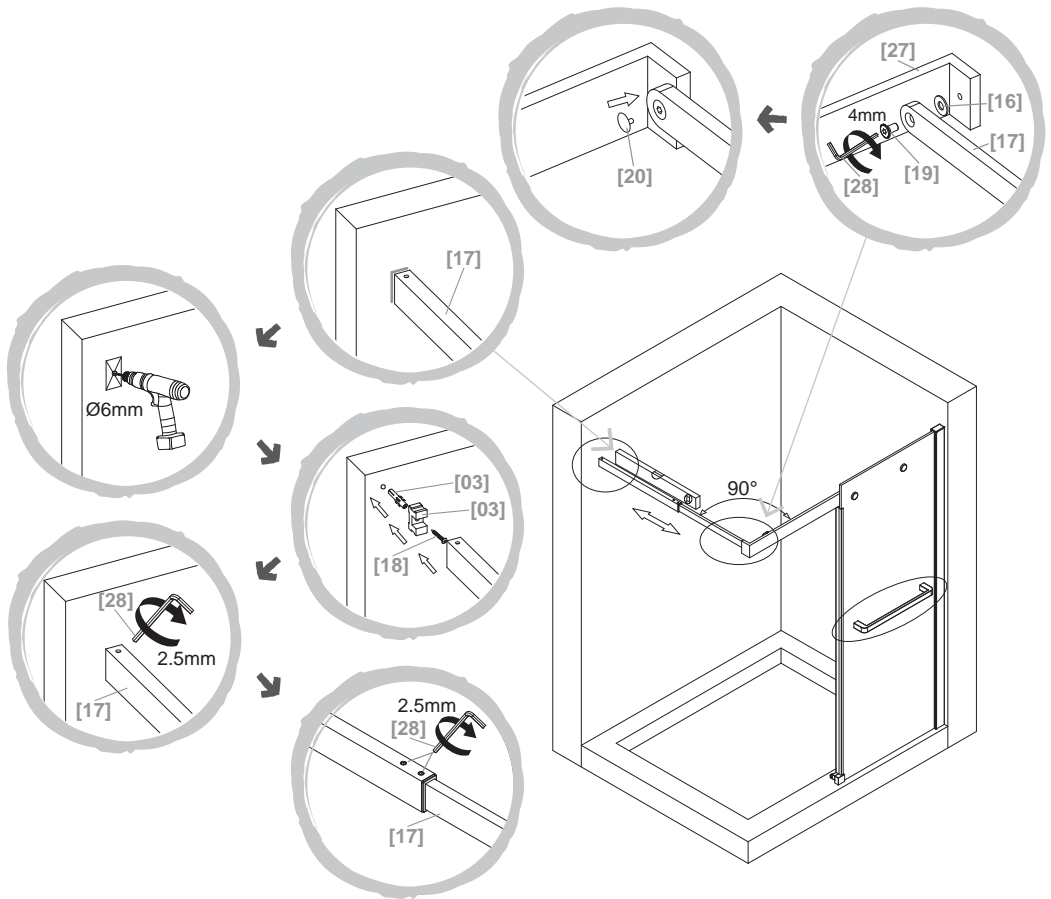

05 B

-  [05] x3
-  [06] x3
-  [07] x3 (ST4 x 6mm)

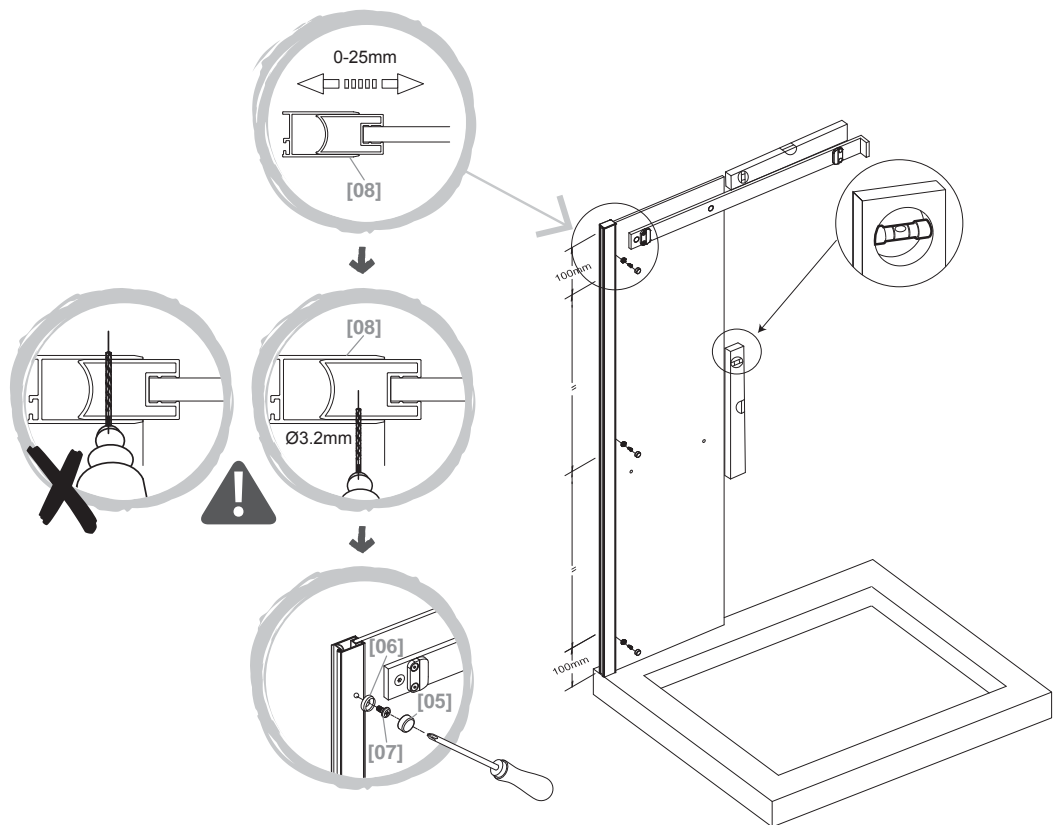

06 B

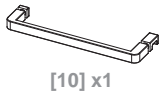

[10] x1



[13b] x1



[13a] x1



[14] x1

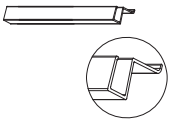

[11] x1



[28] x1
2mm

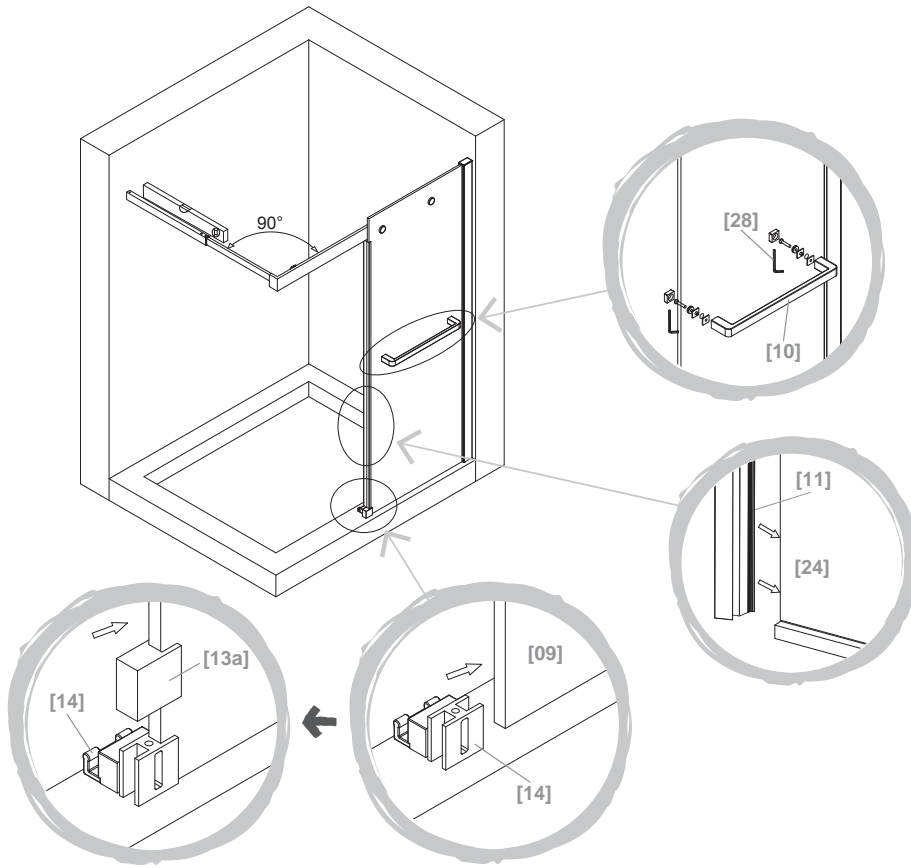

07 B



[22] x2



[25] x1

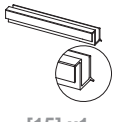

[15] x1

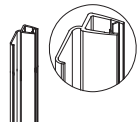

[12] x1



[28] x1
5mm

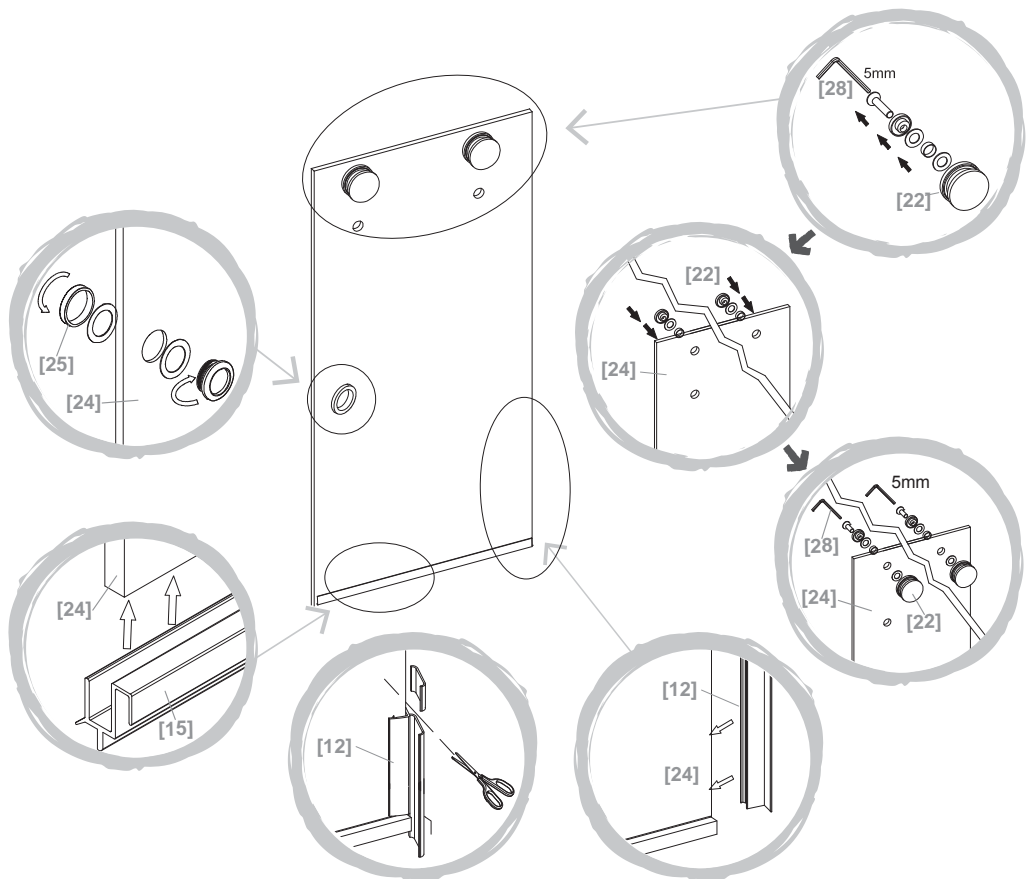

08 **B**

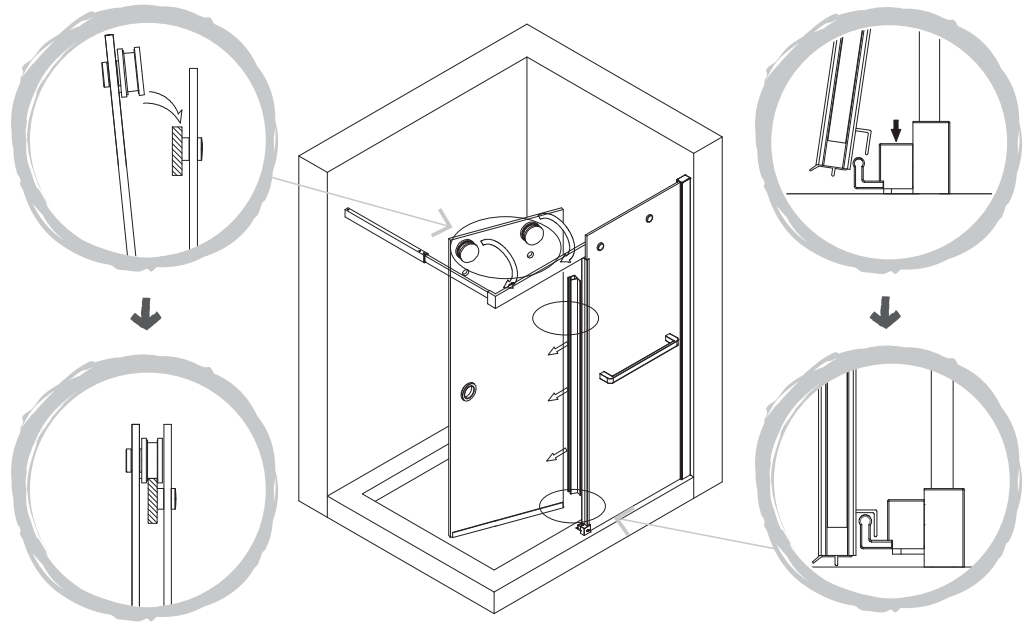

09 **B**

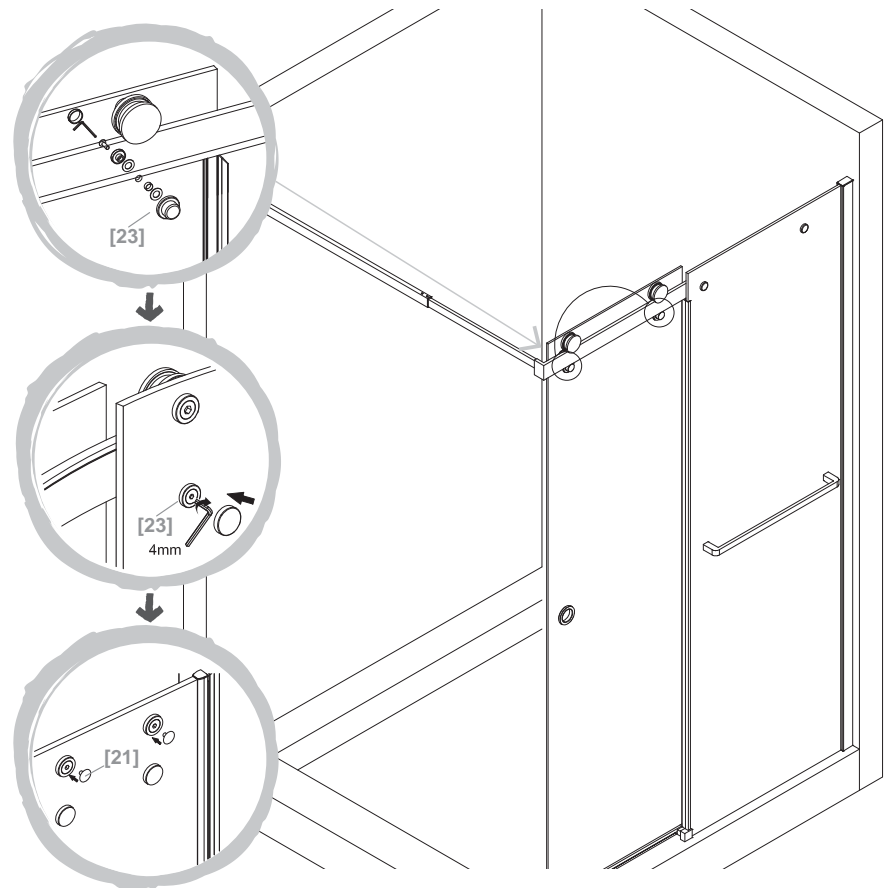

10

B

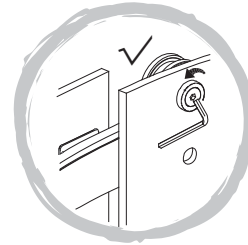
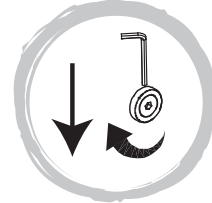
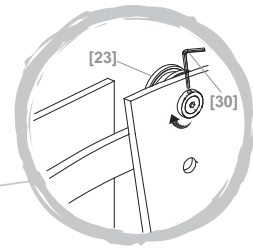
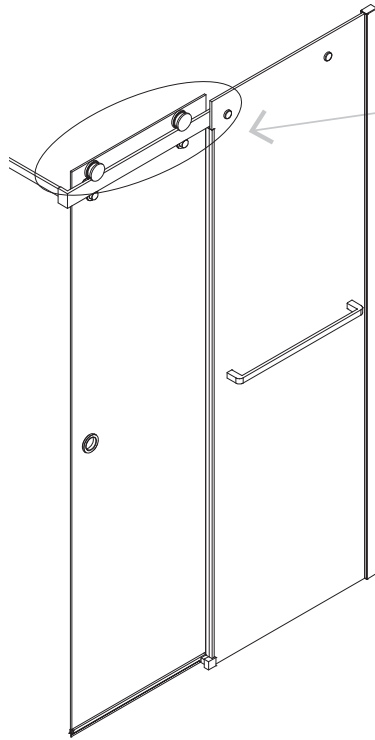

11

B

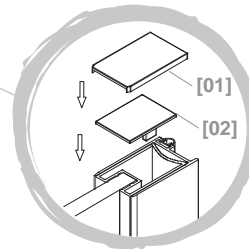
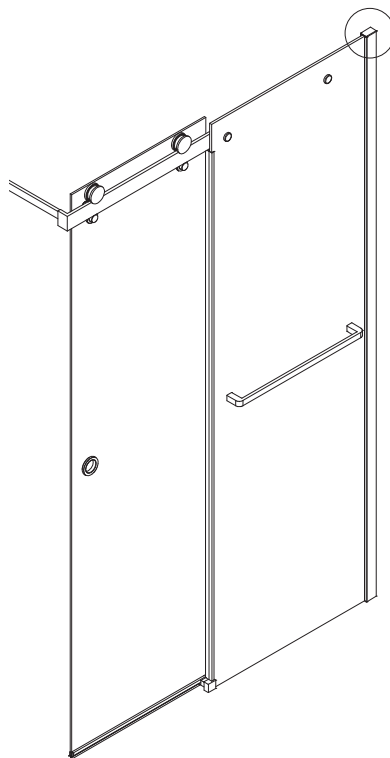

12

B

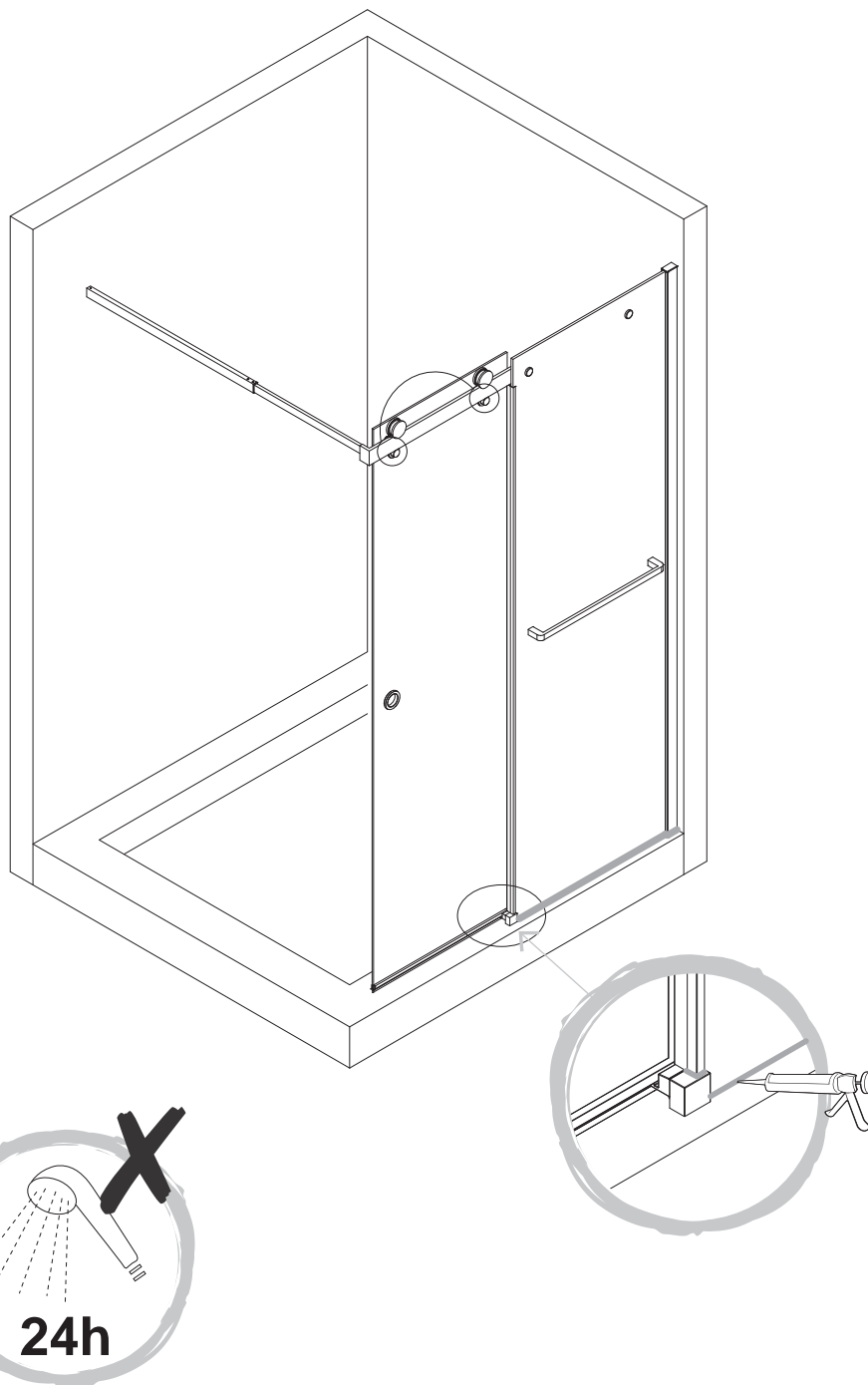

- EN** Do not use the shower enclosure for at least 24 hours in order to allow the silicone sealant to cure fully.
- FR** N'utilisez pas votre douche pendant au moins 24 heures afin de permettre aux joints de silicone de sécher entièrement.
- PL** Po zakończonym montażu, nie używaj brodzika prysznicowego przez co najmniej 24 godziny, aby umożliwić pełne osadzenie się uszczelniacza silikonowego.
- DE** Die Duschkabine darf innerhalb von mindestens 24 Stunden nicht benutzt werden, damit die Silikonversiegelung vollständig abbinden kann.
- RU** Для обеспечения полного высыхания силиконового уплотнителя воздержитесь от пользования душевой кабиной на протяжении 24 часов после установки.
- RO** Nu utilizați cabina de duș timp de cel puțin 24 de ore pentru a permite izolației de silicon să se usuce complet.
- ES** No use la cabina de la ducha por lo menos 24 horas para dejar que el sellador de silicon se fragüe completamente.
- PT** Não utilize a divisória de chuveiro durante, no mínimo, 24 horas para garantir que o vedante de silicone fica totalmente seco.
- TR** Silikon sızdırmazlık malzemesinin tamamen kurumasına izin vermek için duşakabini en az 24 saat boyunca kullanmayın.



EN Care & maintenance
 PL Pielęgnacja i konserwacja
 RUС Уход и обслуживание
 ES Cuidados y Mantenimiento
 TR Bakım ve Onarım

FR Entretien et maintenance
 DE Pflege und Wartung
 RO Îngrijire și întreținere
 PT Cuidados e manutenção

EN

The golden rules for care



NOTE! Use warm soapy water and a soft damp cloth to keep the glass clean. Wipe dry with a clean cloth. Glass cleaner can be used if required. Scourers, abrasives and chemical cleaners can damage the glass and pattern, and should not be used.

In hard water areas, insoluble lime salts may be deposited on the glass. If this is allowed to build up it becomes increasingly difficult to remove and looks unsightly. Regular cleaning will minimize this affect.

- Do not attempt to cut the glass.
- Do not strike the glass with hard or pointed items.
- Regularly check moving parts such as rollers and hinges to ensure they are secure and adjusted correctly. Tighten and adjust where required. Also check all sealed joints to ensure seal has not deteriorated. Re-seal if required.

FR

Les règles d'or pour l'entretien



REMARQUE : Utilisez de l'eau tiède savonneuse et un chiffon doux humide pour garder la vitre propre. Essuyez à l'aide d'un chiffon propre. Si nécessaire, vous pouvez utiliser un produit pour vitres. Grattoirs, abrasifs et nettoyeurs chimiques peuvent endommager la vitre et le motif, et ne doivent ainsi pas être utilisés

Dans les zones dont l'eau est dure, un dépôt de calcaire peut se former sur la vitre. Si vous le laissez s'accumuler, il deviendra de plus en plus difficile à enlever, et sera inesthétique. Un nettoyage régulier permet de réduire cet effet.

- Ne tentez pas de découper la vitre.
- Ne cognez pas la vitre avec des objets durs ou pointus.
- Vérifiez régulièrement les pièces mobiles telles que les rouleaux et charnières afin de vous assurer qu'elles sont solidement fixées et correctement réglées. Serrez et ajustez-les lorsque nécessaire. Vérifiez également tous les joints scellés afin de vous assurer de l'intégrité de l'étanchéité. Scellez à nouveau au besoin.

Kingfisher International Products Limited,
3 Sheldon Square, London, W2 6PX,
United Kingdom

EN Distributor:

B&Q plc, Chandlers Ford, Hants,
SO53 3LE United Kingdom www.diy.com

SFD Limited, Trade House, Mead Avenue,
Yeovil, BA22 8RT, United Kingdom

**Manufacturer, Fabricant, Hersteller,
Producator, Fabricante:**

Kingfisher International Products Limited,
3 Sheldon Square, London, W2 6PX,
United Kingdom

FR Distributeur:

Castorama France C.S. 50101
Templemars 59637 Wattignies CEDEX
www.castorama.fr

BRICO DÉPÔT 30-32 rue de la Tourelle
91310 Longpont-sur-Orge France
www.bricodepot.com

PL Dystrybutor:

Castorama Polska Sp. z o.o. ul.
Krakowiaków 78, 02-255 Warszawa
www.castorama.pl

DE Screwfix Direct Limited Mühlheimer
Straße 15363075 Offenbach/Main
www.screwfix.de

RUS Импортёр:

ООО "Касторама РУС" Дербеневская
наб., дом 7, стр 8 Россия,
Москва, 115114
www.castorama.ru

Изготовитель для России: Чжуншань
Вэйша Бас Эквипмент Ко., Лтд.

Адрес: Синьшэн 3 Стрит, № 11 Фэктори
Билдинг, Ганкоу Таун, Чжуншань Сити.

RO Distribuitor:

SC Bricostore România SA Calea Giulești
1-3, Sector 6, București România
www.bricodepot.ro

ES Distribuidor:

Euro Depot España, S.A.U. c/ La Selva,
10 - Edificio Inblau A 1a Planta 08820-EI
Prat de Llobregat www.bricodepot.es

PT Distribuidor:

Brico Depot Portugal SA Rua Castilho,
5 - 1 esquerdo, sala 13 1250-066 Lisboa
www.bricodepot.pt

TR İthalatçı Firma:

KOÇTAŞ YAPI MARKETLERİ TİC. A.Ş.
Taşdelen Mah. Sırrı Çelik Bulvarı No:5
34788 Taşdelen/Çekmeköy/İSTANBUL
Tel: +90 216 4300300
Faks: +90 216 4844313
www.koctas.com.tr

Yetkili servis istasyonları ve yedek parça
temini için aşağıda yer alan Koçtaş Müşteri
Hattı ve Koçtaş Genel Müdürlük irtibat
bilgilerinden faydalanınız.

KOÇTAŞ MÜŞTERİ HİZMETLERİ
0850 209 50 50



COOKE™
&LEWIS



Naya

V11117

Getting started...

- Check the pack and ensure that you have all of the parts listed.
- When you are ready to start, make sure you have the right tools to hand, plenty of space and a dry area for assembly.
- Ensure the mounting surface is sound, clean and dry before the enclosure is installed.
- The enclosure is designed to allow for 25mm adjustment when fitted to 'out of true walls'.
- The thickness of the tiles used will affect the overall position of the enclosure.
- When drilling through ceramic tiles use a specialist drill bit.
- When working near a tray or bath, ensure that the waste is covered so that small parts do not fall down it.
- Please note: The wall plugs included with this product are suitable for solid walls only. Other wall types may require specialist fixings or wall plugs (not provided). Always ensure that wall plugs or fittings are correct for the wall type. If in doubt seek professional advice.
- Please note that although these instructions are comprehensive, it is always recommended that a technically competent installer should undertake the installation.

Safety

- For domestic use only.
- CAUTION:** Fragile - handle the product with care. This product may cause personal injury, property damage or break easily if not handled, positioned and installed with care.
- CAUTION:** Please handle all glass with care. Any damage to the edges, or scratches to the surface that occur during assembly or normal use can cause the glass to break suddenly. Tempered glass will shatter into very small pieces that will still have sharp edges.
- Do not strike the glass with hard or pointed items.
- Do not attempt to cut the glass.
- CAUTION:** Always ensure the product is securely installed before use.
- Care should be taken when drilling into walls to avoid any hidden pipes or wires.
- CAUTION:** When drilling through ceramic tiles use a specialist drill bit.
- CAUTION:** DO NOT overtighten the fixings otherwise it may damage the product.



WARNING: Failure to follow these instructions may result in personal injury, damage to the product and property damage.

Duration and conditions of guarantee

At Cooke & Lewis, we pay special attention to the selection of high-quality materials and use manufacturing techniques that enable us to create lines of long-lasting designer products. This is why we offer a 10-year warranty against manufacturing defects on our shower enclosures.

This shower enclosure is under warranty for 10 years from the purchase date for normal household, non-professional use. The warranty is valid only upon presentation of the sales slip or purchase invoice. Keep your proof of purchase in a safe place.

The warranty covers product breakdowns and malfunctions subject to compliance with the product's intended use and subject to proper installation and maintenance in accordance with the information in the user guide.

The shower enclosures must be installed so that they can be later removed, without causing damage. This contractual warranty does not cover defects and deterioration caused by the natural wear of the parts, colour variations due to the influence of light over time, bad weather, floods, heat, damage caused by water quality (hardness, abrasiveness, corrosion, etc.), by the presence of foreign objects, whether transported or not by water (sand, filings, etc.) or the lack of room ventilation and damages that could be the result of improper use, misuse, negligence, accident or faulty maintenance.

The following are also excluded from warranty claims: adverse effects due to the use of non-genuine or unsuitable accessories and/or replacement parts, product disassembly or product modification.

The warranty does not cover the breakage of tempered glass enclosures, whether it occurs during unpacking, assembly or transportation of the product, or after its installation.

The warranty is limited to parts recognised as defective. In no case shall it cover ancillary costs (travel, labour) and direct and indirect damages.

Guarantee related queries should be addressed to a store affiliated with the distributor you purchased the product from.

This guarantee is in addition to and does not affect your statutory rights.

Declaration of Performance available on www.diy.com

Distributor: B&Q plc, Chandlers Ford, Hants, SO53 3LE United Kingdom www.diy.com
SFD Limited, Trade House, Mead Avenue, Yeovil, BA22 8RT, United Kingdom

Pour bien commencer...

- Vérifiez le contenu du paquet et assurez-vous que tous les composants répertoriés sont présents.
- Lorsque vous êtes prêt pour commencer, veillez à disposer des bons outils à portée de main, de suffisamment d'espace et d'un endroit sec pour le montage.
- Assurez-vous que la surface de montage est solide, propre et sèche avant l'installation de la paroi.
- Assurez-vous que la paroi est fixée à un bac au sol nivelé et à des murs verticaux.
- L'épaisseur des carreaux utilisés affectera la position d'ensemble de la paroi.
- Lors de perçages dans des carreaux en céramique, utilisez un foret adapté.
- Lors de travaux effectués à proximité d'un bac ou d'une baignoire, assurez-vous que les ouvertures soient couvertes afin qu'aucun petit morceau n'y tombe.
- Remarque : les chevilles murales fournies avec ce produit conviennent pour les murs pleins uniquement. Les autres types de murs peuvent éventuellement nécessiter des fixations ou chevilles murales spéciales (non fournies). Assurez-vous toujours que les chevilles murales ou fixations sont adaptées au type de mur. En cas de doute, obtenez des conseils professionnels.
- Remarque importante : Bien que ces instructions soient complètes, il est toujours recommandé que l'installation soit réalisée par un installateur professionnel.

Sécurité

- Utilisation domestique uniquement.
- ATTENTION :** Fragile - manipulez le produit avec précaution. Ce produit peut causer des blessures, des dommages matériels ou se casser facilement s'il n'est pas manipulé, disposé et installé avec soin.
- ATTENTION :** Veuillez manipuler toute vitre avec précaution. Tout endommagement des bords ou rayure sur la surface susceptible de se produire en cours de montage ou d'utilisation normale peut provoquer la cassure soudaine de la vitre. Le verre peut voler en petits éclats, dont les bords sont tout de même tranchants.
- Ne cognez pas la vitre avec des objets durs ou pointus.
- Ne tentez pas de découper la vitre.
- ATTENTION :** Assurez-vous toujours que le produit est correctement installé avant de l'utiliser.
- Des précautions doivent être prises lors des perçages dans le mur pour éviter les tuyaux et les fils cachés.
- ATTENTION :** Lors de perçages dans des carreaux en céramique, utilisez un foret spécial.
- ATTENTION :** NE serrez PAS les fixations excessivement. Cela pourrait endommager le produit.



AVERTISSEMENT : Le non-respect de ces instructions peut entraîner des blessures corporelles, des dommages au produit et des dommages à la propriété.

Durée et conditions de garantie

Chez Cooke & Lewis, nous apportons une attention toute particulière dans le choix de matériaux de haute qualité et utilisons des techniques de fabrication qui nous permettent de créer des gammes de produits design et durable. C'est pourquoi nous vous proposons une garantie de 10 ans contre les défauts de fabrication sur nos parois de douche.

Cette paroi de douche est garantie 10 ans à compter de la date d'achat, dans le cadre d'un usage ménager normal, non professionnel. La garantie ne peut s'appliquer que sur présentation du ticket de caisse ou de la facture d'achat. Conservez votre preuve d'achat dans un endroit sûr.

La garantie couvre les pannes et dysfonctionnements du produit sous réserve d'une utilisation conforme à la destination du produit et sous réserve d'une installation et d'un entretien conformes aux règles de l'art et aux informations du manuel d'utilisation.

Les parois de douche devront avoir été installées de telle sorte qu'elles puissent être retirées ultérieurement, sans détérioration. Cette garantie contractuelle ne couvre pas les défauts et détériorations provoqués par l'usure naturelle des pièces, les variations de teinte dues à l'influence de la lumière dans le temps, les intempéries, les inondations, les dégagements de chaleur, les dommages causés par la qualité de l'eau (calcaire, agressivité, corrosion, ...), par la présence de corps étrangers véhiculés ou non par l'eau (sable, limailles, ...) ou le manque d'aération de la pièce et les dommages qui pourraient être la conséquence d'un usage inapproprié, d'une utilisation abusive, d'une négligence, d'un accident ou d'un entretien défectueux.

Sont également exclues de la garantie les conséquences néfastes dues à l'emploi d'accessoires et/ou de pièces de rechange non d'origine, ou non adaptées, au démontage ou à la modification du produit.

La garantie ne couvre pas la casse des parois en verre trempé, qu'elle intervienne durant le déballage, le montage, le transport du produit, ou après son installation.

La garantie est limitée aux pièces reconnues défectueuses. Elle ne couvre, en aucun cas, les frais annexes (déplacement, main d'œuvre) et les dommages directs et indirects.

Indépendamment de cette garantie commerciale, le vendeur reste tenu de la garantie légale de conformité mentionnée aux articles L. 217-4 à L. 217-12 et de celle relative aux défauts de la chose vendue, dans les conditions prévues aux articles 1641 à 1648 et 2232 du code civil.

Article L217-4 du code de la consommation :

Le vendeur livre un bien conforme au contrat et répond des défauts de conformité existants lors de la délivrance.

Il répond également des défauts de conformité résultant de l'emballage, des instructions de montage ou de l'installation lorsque celle-ci a été mise à sa charge par le contrat ou a été réalisée sous sa responsabilité.

Article L217-5 du code de la consommation :

Le bien est conforme au contrat :

1° S'il est propre à l'usage habituellement attendu d'un bien semblable et, le cas échéant :

- s'il correspond à la description donnée par le vendeur et possède les qualités que celui-ci a présentées à l'acheteur sous forme d'échantillon ou de modèle ;

- s'il présente les qualités qu'un acheteur peut légitimement attendre eu égard aux déclarations publiques faites par le vendeur, par le producteur ou par son représentant, notamment dans la publicité ou l'étiquetage ;

2° Ou s'il présente les caractéristiques définies d'un commun accord par les parties ou est propre à tout usage spécial recherché par l'acheteur, porté à la connaissance du vendeur et que ce dernier a accepté.

Article L217-12 du code de la consommation :

L'action résultant du défaut de conformité se prescrit par deux ans à compter de la délivrance du bien.

Article L217-16 du code de la consommation :

Cette période court à compter de la demande d'intervention de l'acheteur ou de la mise à disposition pour réparation du bien en cause, si cette mise à disposition est postérieure à la demande d'intervention.

Article 1641 du code civil :

Le vendeur est tenu de la garantie à raison des défauts cachés de la chose vendue qui la rendent impropre à l'usage auquel on la destine, ou qui diminuent tellement cet usage que l'acheteur ne l'aurait pas acquise, ou n'en aurait donné qu'un moindre prix, s'il les avait connus.

Article 1648 alinéa 1er du code civil :

L'action résultant des vices rédhibitoires doit être intentée par l'acquéreur dans un délai de deux ans à compter de la découverte du vice.

Ceci n'affecte pas vos droits légaux.

Lorsque l'acheteur demande au vendeur, pendant le cours de la garantie commerciale qui lui a été consentie lors de l'acquisition ou de la réparation d'un bien meuble, une remise en état couverte par la garantie, toute période d'immobilisation d'au moins sept jours vient s'ajouter à la durée de la garantie qui restait à courir.

Pour toutes requêtes relatives à la garantie, veuillez-vous adresser à un magasin affilié au distributeur auprès duquel vous avez acheté ce produit.

Déclaration de performance disponible sur www.castorama.fr et www.bricodepot.fr

Distributeur: Castorama France C.S. 50101 Templemars 59637 Wattignies CEDEX www.castorama.fr

BRICO DÉPÔT 30-32 rue de la Tourelle 91310 Longpont-sur-Orge France www.bricodepot.com

PL

Pierwsze kroki...

- Sprawdź zawartość opakowania, aby upewnić się, że znajdują się w nim wszystkie części.
- Przed rozpoczęciem montażu upewnij się, że posiadasz odpowiednie narzędzia, wystarczająco dużo miejsca oraz suchą przestrzeń pod montaż.
- Przed rozpoczęciem instalacji kabiny upewnij się, że powierzchnia montażu jest stabilna, czysta i sucha.
- Upewnij się, że kabina została przymocowana do wy poziomowanego brodzika lub podłogi oraz do pionowej ściany.
- Grubość położonych na ścianie kafelków ma wpływ na ostateczną pozycję ułożenia kabiny na brodziku.
- Do wiercenia przez kafelki ceramiczne używaj specjalnego wiertła.
- Podczas pracy w okolicy brodzika lub wanny, upewnij się, że odpływ jest zamknięty, dzięki czemu małe części nie mogą do niego wpaść.
- Informacja: Kołki rozporowe dołączone do produktu są przeznaczone wyłącznie do montażu na litych ścianach. Montaż na ścianach innego typu wymaga specjalnych elementów montażowych lub kołków rozporowych (nie dołączone). Zawsze upewnij się, że kołki rozporowe i elementy montażowe są właściwie dobrane dla danego typu ściany. W razie wątpliwości zasięgnij porady specjalisty.
- Pamiętaj. Pomimo, że instrukcje instalacji są kompleksowe, to zawsze zalecane jest przeprowadzenie montażu przez wykwalifikowanego fachowca.

Bezpieczeństwo

- Produkt przeznaczony do użytku domowego.
- UWAGA:** Szkło - bądź ostrożny podczas obchodzenia się z produktem. Niniejszy produkt może doprowadzić do urazu użytkownika, uszkodzenia mienia lub może stłuc się, jeśli należyta ostrożność nie zostanie zachowana podczas instalacji.
- UWAGA:** Proszę zachować ostrożność podczas obchodzenia się z szybami. Jakiegokolwiek uszkodzenia krawędzi lub zadrapania powierzchni spowodowane podczas montażu bądź normalnego użycia, mogą doprowadzić do nagłego stłuczenia się szyby. Szkło hartowane rozkruszy się na bardzo małe kawałki z ostrymi krawędziami.
- Nie uderzaj w szyby twardymi lub szpiczastymi przedmiotami.
- Nie przecinaj szyby.

- UWAGA:** przed użyciem zawsze upewnij się, że produkt jest bezpiecznie zainstalowany.
- Zachowaj ostrożność podczas wiercenia ściany, aby nie uszkodzić rur oraz przewodów elektrycznych.
- UWAGA:** Do wiercenia przez kafelki ceramiczne używaj specjalnego wiertła.
- UWAGA:** NIE dokręcaj mocowań zbyt mocno, gdyż może to uszkodzić produkt.



OSTRZEŻENIE: Nie przestrzeganie niniejszych instrukcji może doprowadzić do urazu użytkownika, zniszczenia lub uszkodzenia mienia.

Czas obowiązywania i warunki gwarancji

W firmie Cooke i Lewis poświęcany szczególną uwagę na wybór wysokiej jakości materiałów i używamy technik produkcyjnych umożliwiających stworzenie nowoczesnych i trwałych gam produktów. Dlatego też proponujemy Państwu gwarancję na okres 10 lat na wady fabryczne naszych drzwi prysznicowych.

Gwarancja drzwi prysznicowych jest ważna 10 lat/a od daty zakupu, w ramach normalnego użytku w gospodarstwie domowym a nie w środowisku profesjonalnym. Gwarancja jest ważna wyłącznie po okazaniu paragonu lub faktury zakupu. Prosimy zachować dowód zakupu w bezpiecznym miejscu.

Gwarancja obejmuje usterki i niewłaściwe działanie produktu, z zastrzeżeniem stosowania zgodnie z przeznaczeniem produktu i instalacji oraz konserwacji zgodnych z zasadami dobrej praktyki i z informacjami zawartymi w instrukcji użytkownika.

Drzwi prysznicowe należy zainstalować tak, by mogły być później demontowane bez uszkodzenia. Gwarancja umowna nie obejmuje wad i uszkodzeń spowodowanych naturalnym zużyciem części, zmian koloru pod wpływem światła w czasie, czynników pogodowych, powodzi, wytwarzanie ciepła, uszkodzeń spowodowanych jakością wody (wapień, korozja...), obecnością obcych ciał przenoszonych w wodzie lub poza nią (piasek, opiłki...) lub brak wentrowania pomieszczenia oraz uszkodzeń na skutek niewłaściwego lub niedbałego używania, niezgodnego z przeznaczeniem, wypadku lub wadliwej konserwacji.

Szkodliwe skutki spowodowane używaniem nieoryginalnych, niedostosowanych akcesoriów i/lub części zamiennych, demontażem lub zmianą produktu są również wyłączone z gwarancji.

Gwarancja nie obejmuje zbitcia drzwi ze szkła hartowanego, które nastąpiło podczas rozpakowywania, montażu, transportu produktu lub po instalacji.

Gwarancja jest ograniczona do części uznanych za wadliwe. Nie obejmuje ona w żadnym razie dodatkowych kosztów (dojazd, siła robocza) oraz bezpośrednich i pośrednich uszkodzeń.

Udzielenie przez Gwaranta gwarancji nie wyłącza, nie ogranicza ani nie zawiesza uprawnień Kupującego wynikających z przepisów o rękojmi za wady rzeczy sprzedanej.

Deklaracja właściwości użytkowych dostępna na www.castorama.pl

Gwarant: Castorama Polska Sp. z o.o. ul. Krakowiaków 78, 02-255 Warszawa www.castorama.pl

DE

Anfangen...

- Überprüfen Sie den Inhalt und stellen Sie sicher, dass alle aufgelisteten Teile mitgeliefert wurden.
- Wenn Sie startbereit sind, sollten alle benötigten Werkzeuge zur Hand sein. Es muss viel Platz sowie ein trockener Bereich für die Montage vorhanden sein.
- Stellen Sie vor der Montage der Kabine sicher, dass die Montagefläche einwandfrei, sauber und trocken ist.
- Die Kabine muss an einer ebenen Duschtasse bzw. -wanne und vertikalen Wänden montiert werden.
- Die Kabine ist bei Montage an "echten Wänden" für ein Spiel von 8 mm ausgelegt.
- Die Dicke der Fliesen beeinflusst die Position der Duschwand auf der Duschwanne.
- Zum Durchbohren von Keramikfliesen muss ein spezieller Bohrer eingesetzt werden.
- Bei Arbeiten in der Nähe einer Duschtaste oder -wanne sollte immer darauf geachtet werden, dass der Ablauf verschlossen wird, damit keine Kleinteile dort hineinfallen können.
- Bitte beachten: Die dem Produkt beiliegenden Dübel sind nur für massive Wände geeignet. Bei anderen Wandkonstruktionen werden unter Umständen spezielle Befestigungsmittel bzw. Wanddübel benötigt (nicht mitgeliefert). Achten Sie immer darauf, dass die Wanddübel bzw. Befestigungsmittel für den jeweiligen Wandtyp geeignet sind. Fragen Sie im Zweifelsfall in einem Fachbetrieb nach.
- Zwar sind diese Anweisungen ausführlich, jedoch empfiehlt es sich, stets einen technisch erfahrenen Monteur für die Installation zu Hilfe zu nehmen.

Sicherheit

- Nur für den Privatgebrauch.
- VORSICHT:** Zerbrechlich - Produkt mit Vorsicht behandeln. Wenn dieses Produkt nicht vorsichtig behandelt, abgesetzt und montiert wird, kann es zu Verletzungen oder Sachschäden kommen oder das Produkt kann leicht zerbrechen.
- VORSICHT:** Glas immer sehr vorsichtig behandeln. Jede Beschädigung an den Kanten oder Kratzer auf der Oberfläche, die während der Montage oder des normalen



Kingfisher International Products Limited,
3 Sheldon Square, London, W2 6PX,
United Kingdom
17
DoP_W34742_3663602769699_1
3663602769699
PH - HP - IP
Do higieny osobistej
EN14428
CA - IR - DA



Kingfisher International Products Limited,
3 Sheldon Square, London, W2 6PX,
United Kingdom
17
DoP_W34742_3663602769705_1
3663602769705
PH - HP - IP
Do higieny osobistej
EN14428
CA - IR - DA



Kingfisher International Products Limited,
3 Sheldon Square, London, W2 6PX,
United Kingdom
17
DoP_W34742_3663602769712_1
3663602769712
PH - HP - IP
Do higieny osobistej
EN14428
CA - IR - DA



Kingfisher International Products Limited,
3 Sheldon Square, London, W2 6PX,
United Kingdom
17
DoP_W34742_3663602769736_1
3663602769736
PH - HP - IP
Do higieny osobistej
EN14428
CA - IR - DA



Kingfisher International Products Limited,
3 Sheldon Square, London, W2 6PX,
United Kingdom
17
DoP_W34742_3663602769743_1
3663602769743
PH - HP - IP
Do higieny osobistej
EN14428
CA - IR - DA



Kingfisher International Products Limited,
3 Sheldon Square, London, W2 6PX,
United Kingdom
17
DoP_W34742_3663602769750_1
3663602769750
PH - HP - IP
Do higieny osobistej
EN14428
CA - IR - DA



Kingfisher International Products Limited,
3 Sheldon Square, London, W2 6PX,
United Kingdom
17
DoP_W34742_3663602769729_1
3663602769729
PH - HP - IP
Do higieny osobistej
EN14428
CA - IR - DA



Kingfisher International Products Limited,
3 Sheldon Square, London, W2 6PX,
United Kingdom
17
DoP_W34742_3663602769767_1
3663602769767
PH - HP - IP
Do higieny osobistej
EN14428
CA - IR - DA



Kingfisher International Products Limited,
3 Sheldon Square, London, W2 6PX,
United Kingdom
17
DoP_W34742_3663602769774_1
3663602769774
PH - HP - IP
Do higieny osobistej
EN14428
CA - IR - DA



Kingfisher International Products Limited,
3 Sheldon Square, London, W2 6PX,
United Kingdom
17
DoP_W34742_3663602769781_1
3663602769781
PH - HP - IP
Do higieny osobistej
EN14428
CA - IR - DA



Kingfisher International Products Limited,
3 Sheldon Square, London, W2 6PX,
United Kingdom
17
DoP_W34742_3663602769798_1
3663602769798
PH - HP - IP
Do higieny osobistej
EN14428
CA - IR - DA



Kingfisher International Products Limited,
3 Sheldon Square, London, W2 6PX,
United Kingdom
17
DoP_W34742_3663602769804_1
3663602769804
PH - HP - IP
Do higieny osobistej
EN14428
CA - IR - DA



Kingfisher International Products Limited,
3 Sheldon Square, London, W2 6PX,
United Kingdom
17
DoP_W34742_3663602769811_1
3663602769811
PH - HP - IP
Do higieny osobistej
EN14428
CA - IR - DA