

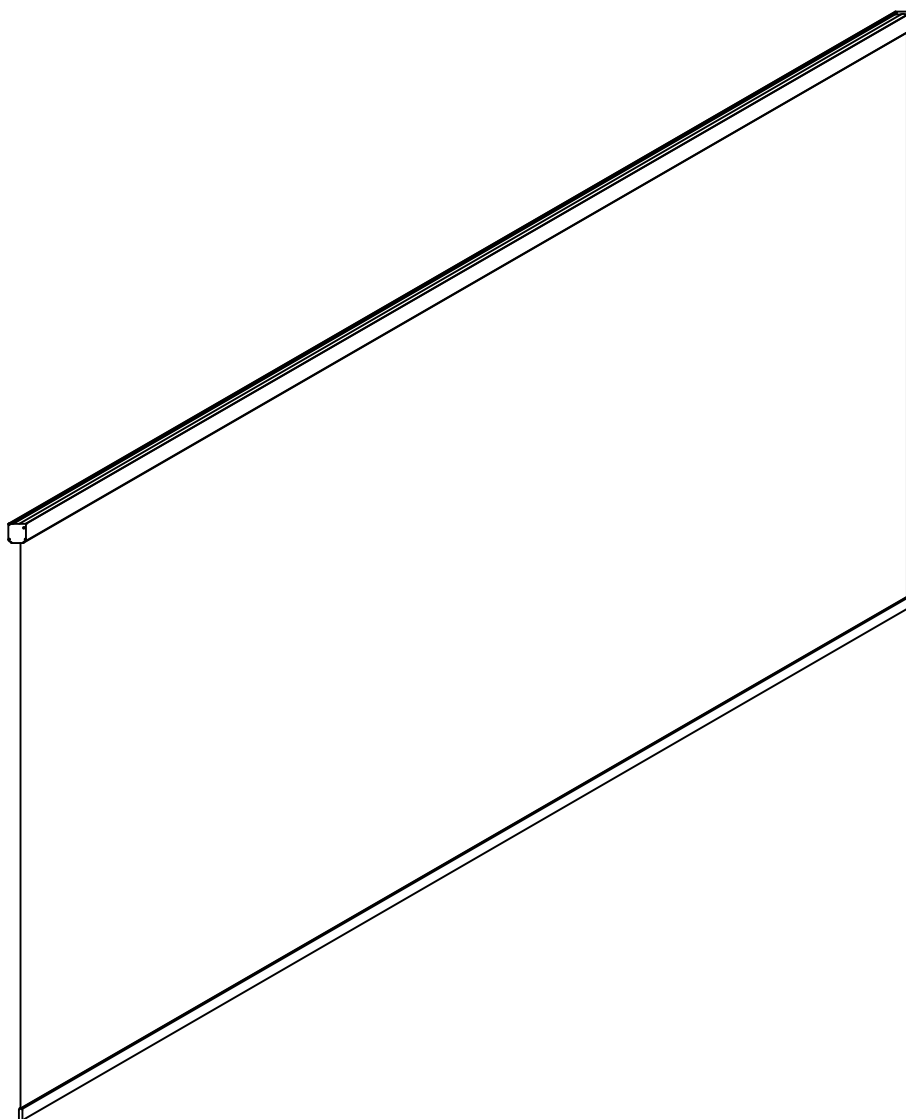

Notice montage Rideau motorisé 6m

*spécifique pour pergola bioclimatique
Green Outside modèle XXL 6x3*



Notice à conserver et à consulter attentivement avant montage. Porter les protections appropriées

Pour tout contact en cas de besoin:

sav@green-outside.com

Green Outside sas, 21 route d'Alex, 01100 Bellignat



LE TRI
+ FACILE

NOTICE PAPIER
& CARTON



nomenclature des pièces

à vérifier avant montage

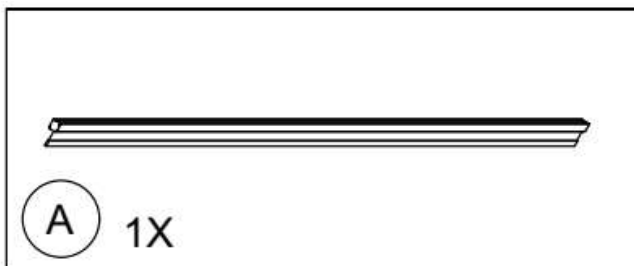

1X

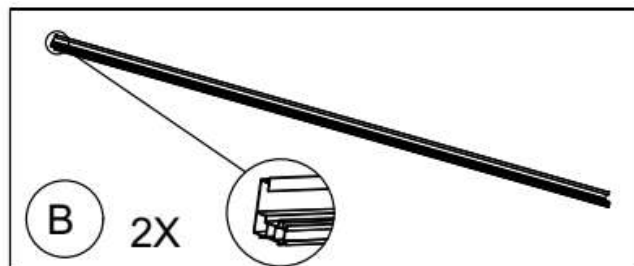

2X

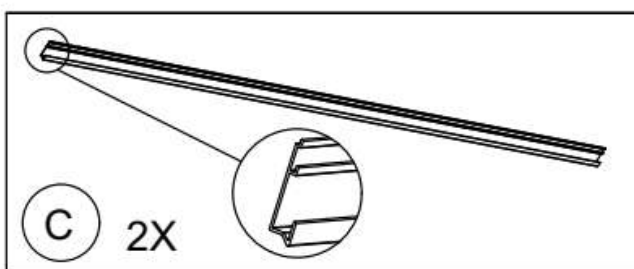

2X

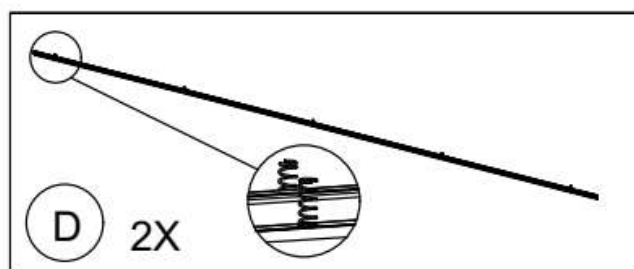

2X

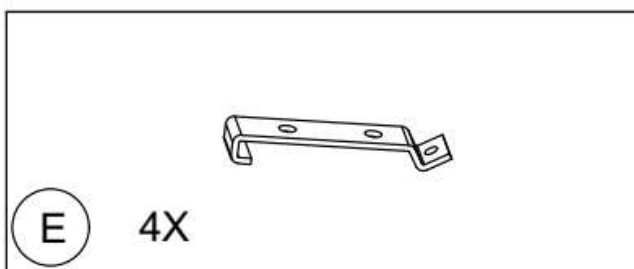

4X

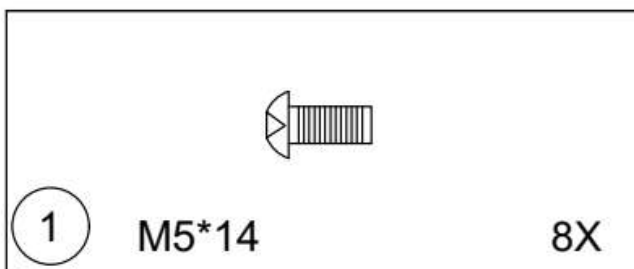

M5*14

8X

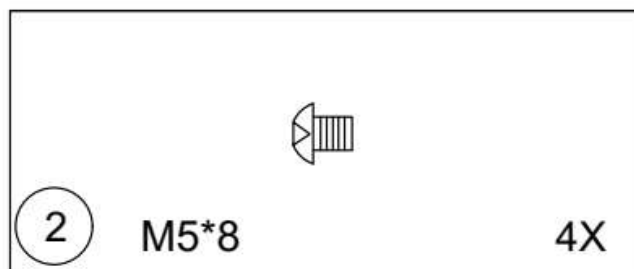

M5*8

4X

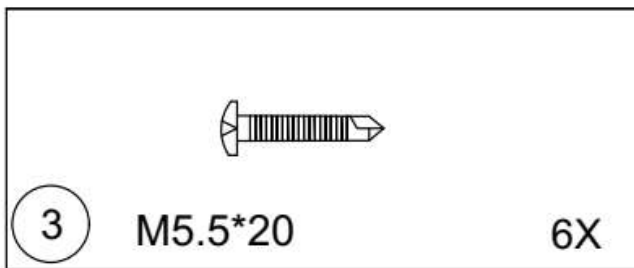

M5.5*20

6X

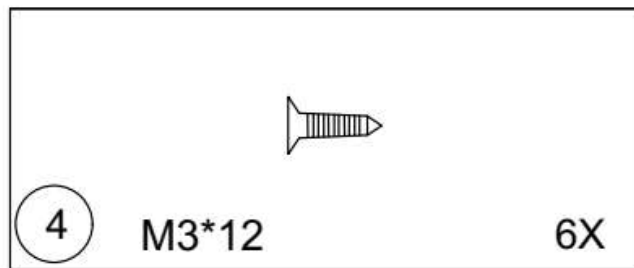

M3*12

6X



Installer les pattes de fixation "E" sur la poutre 6m.

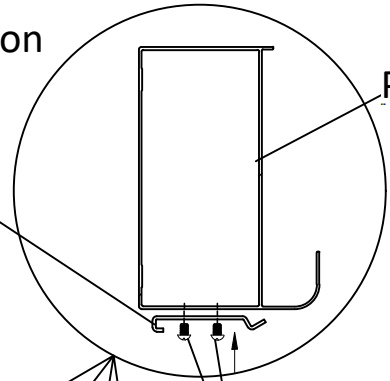

Poutre

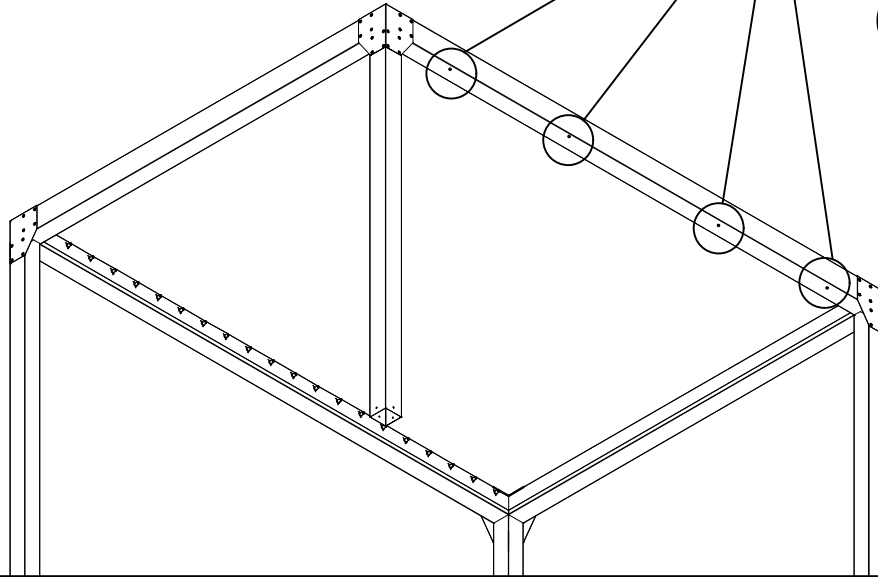

Au sol, dévisser les vis à chaque extrémité du capot, et retirer le du coffre.

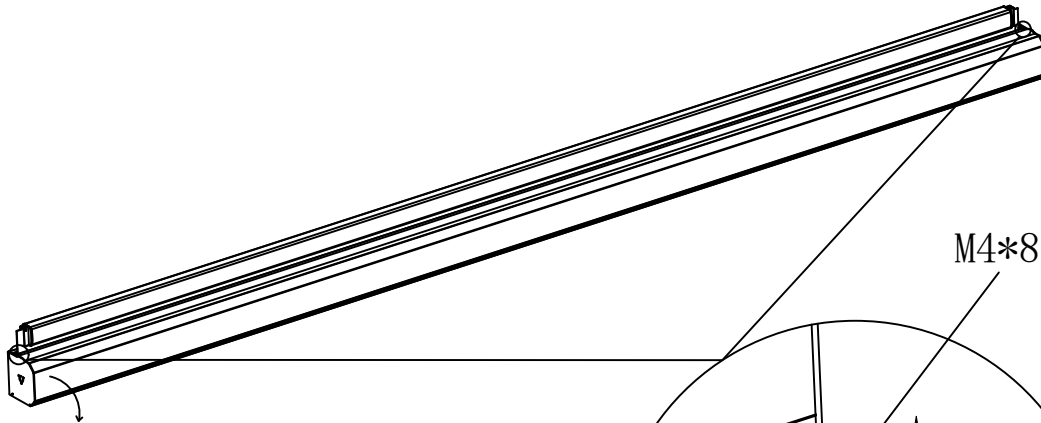

M4*8

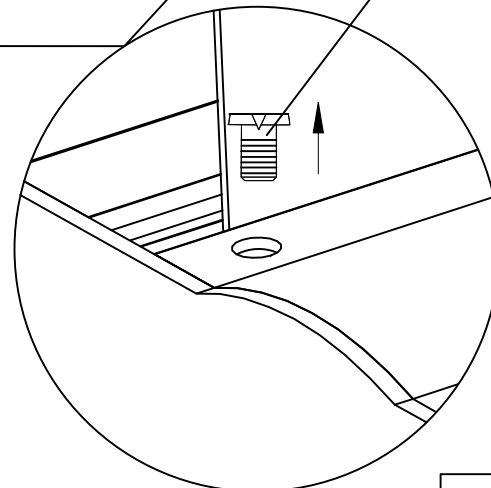

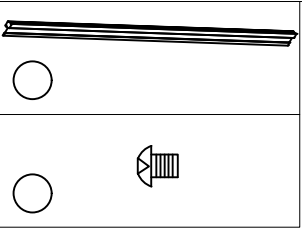

Installer le coffre rideau dans son emplacement, et verrouiller la fixation avec les vis.

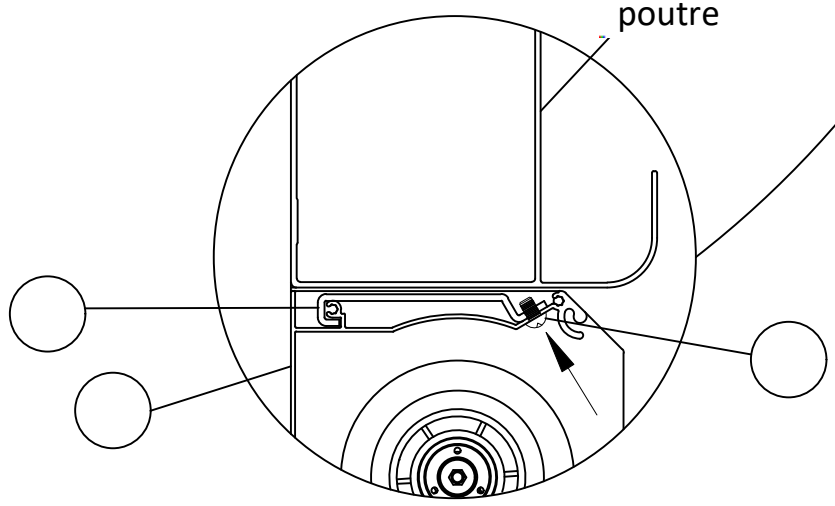
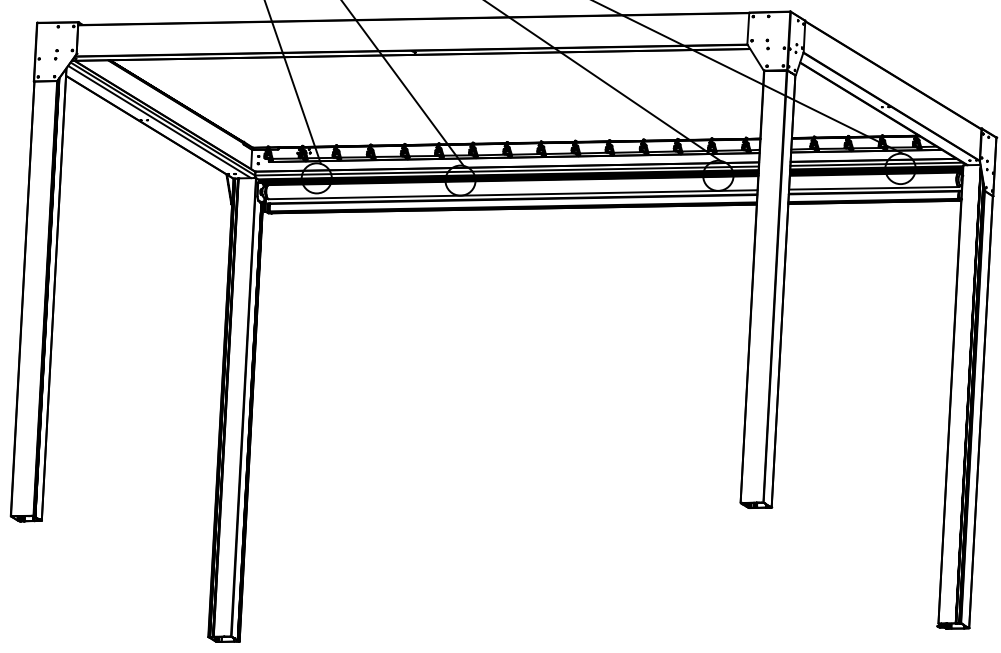
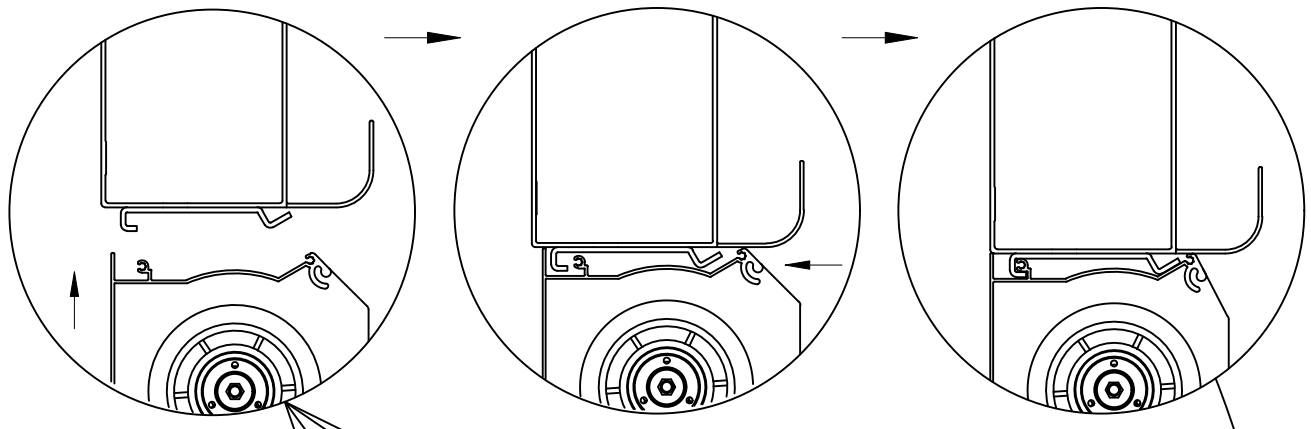

Remettre le capot du coffre rideau, et revisser les 2 vis aux extrémités

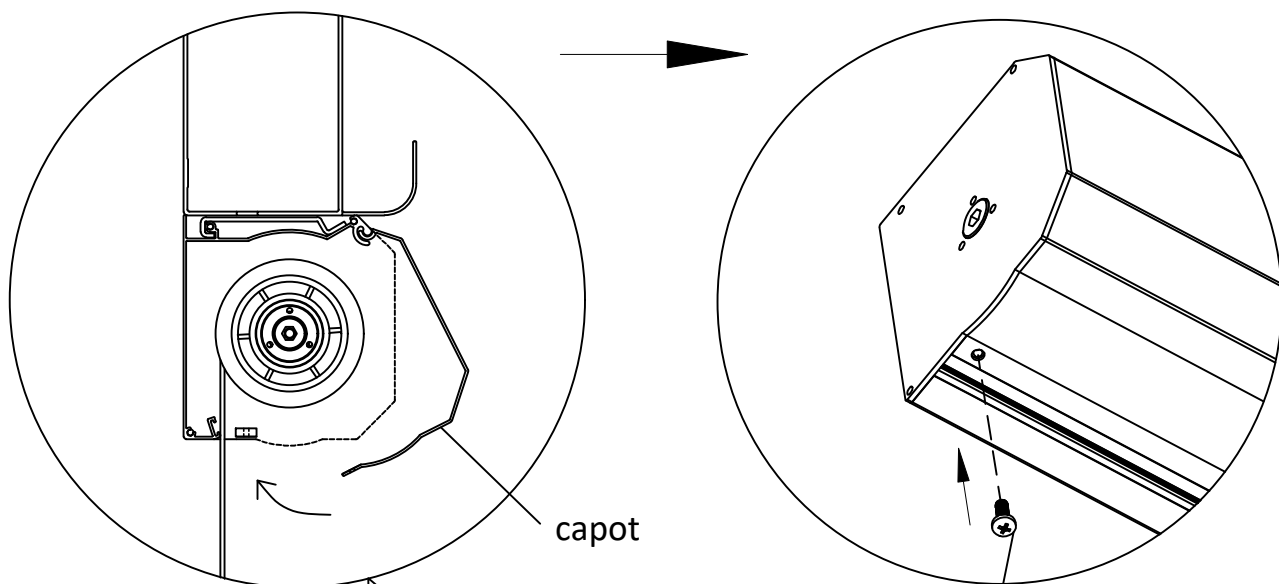

capot



M4*8

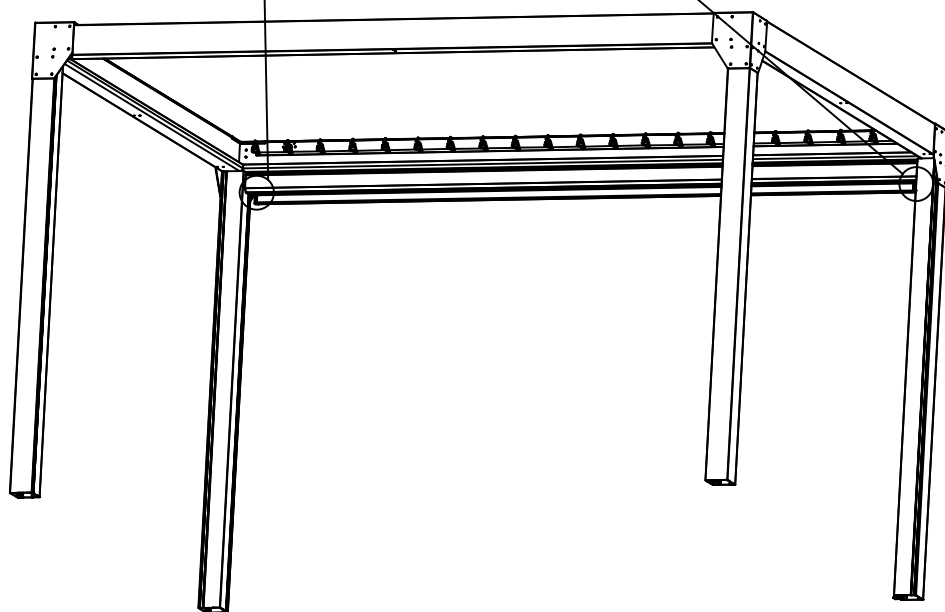

Brancher la connectique rideau.
Le câble peut ensuite être logé dans le poteau

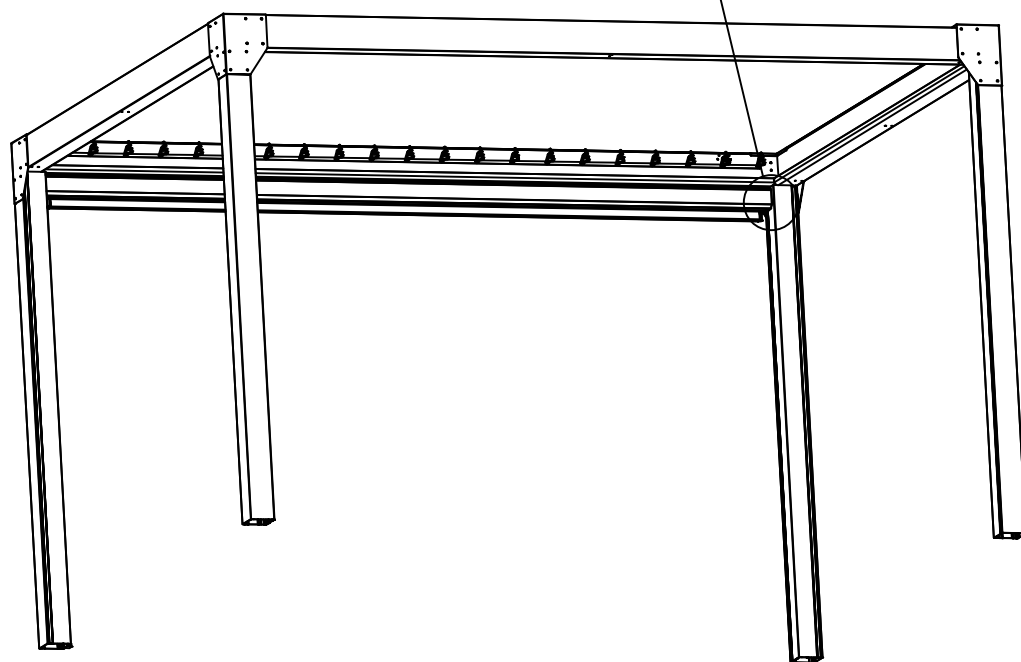
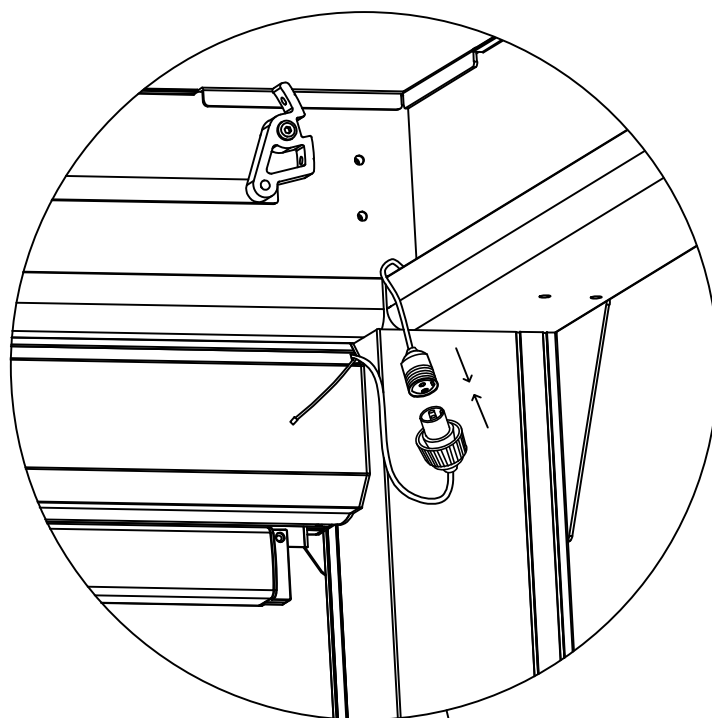

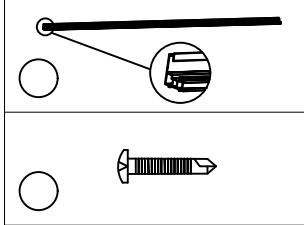

Installer les rail de guidage dans leur emplacement (rainurage) sur chacun des poteaux et visser.

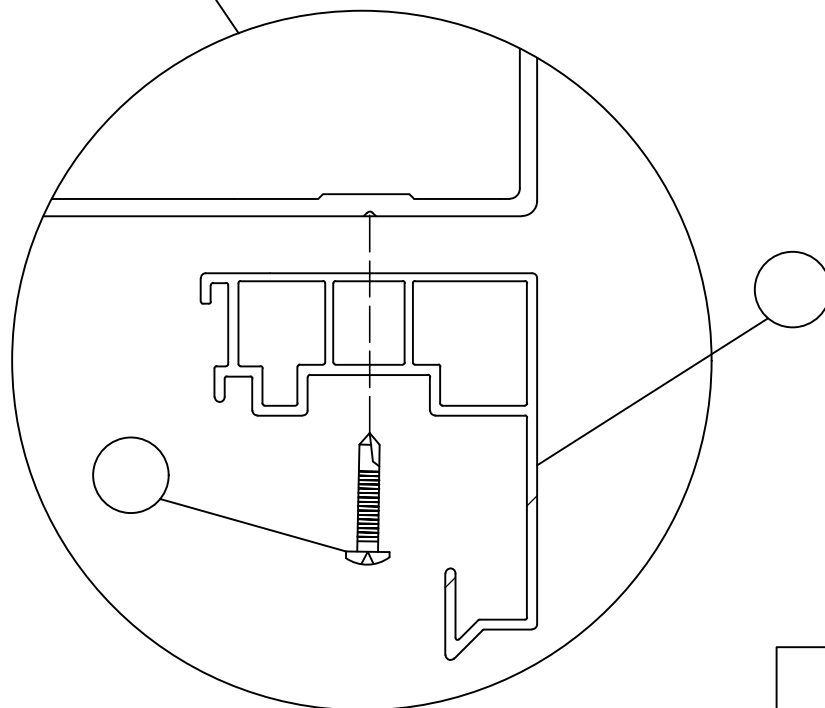
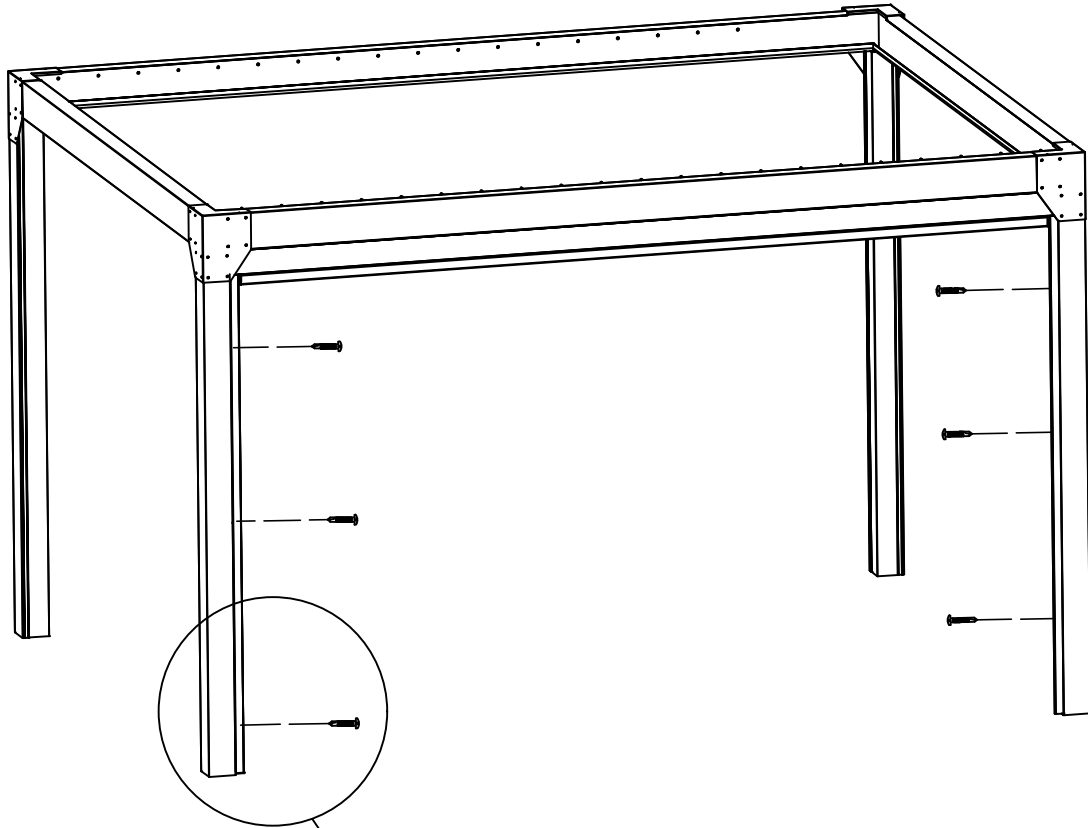

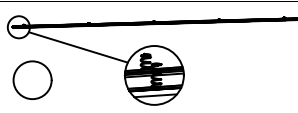

Installer la glissière plastique de maintien du rideau, avec ressort, dans son logement, partie biseautée vers le haut. Vérifier la bonne mise en place avant de passer à la suite.

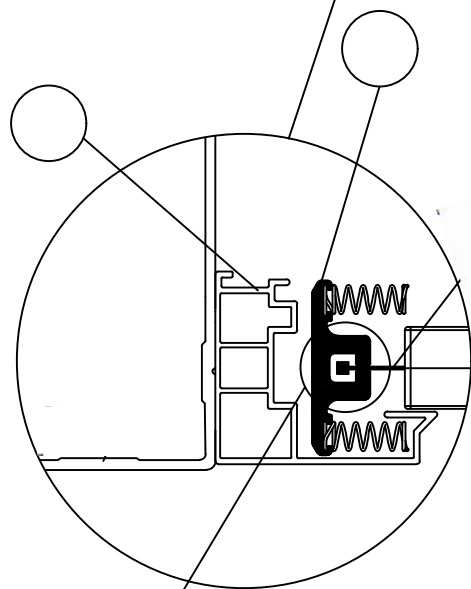
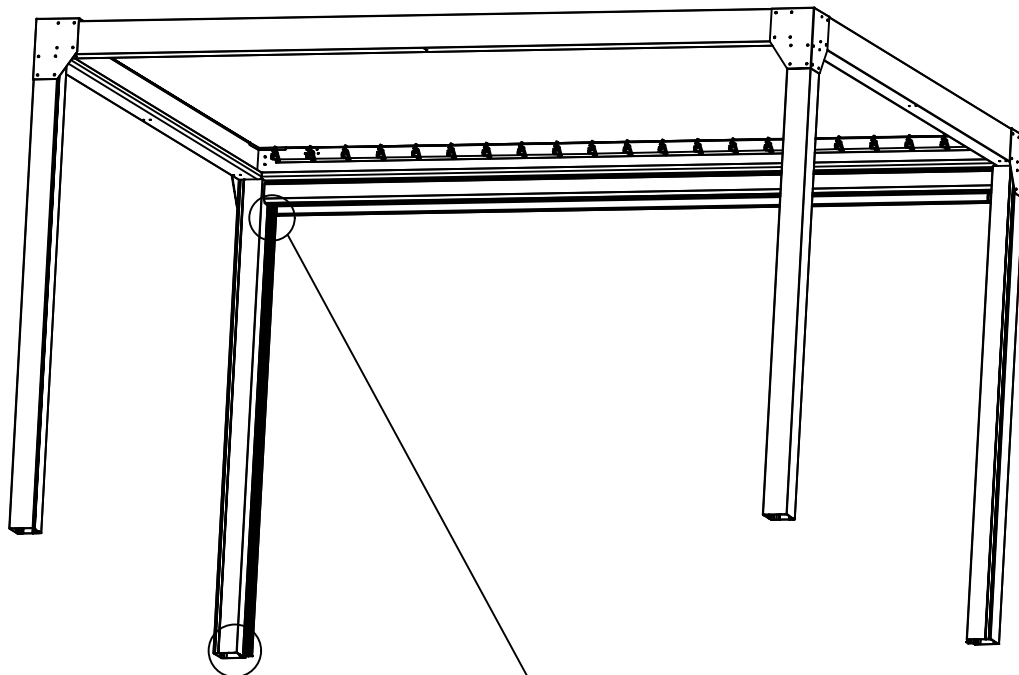

Le rideau doit être passé dans la glissière

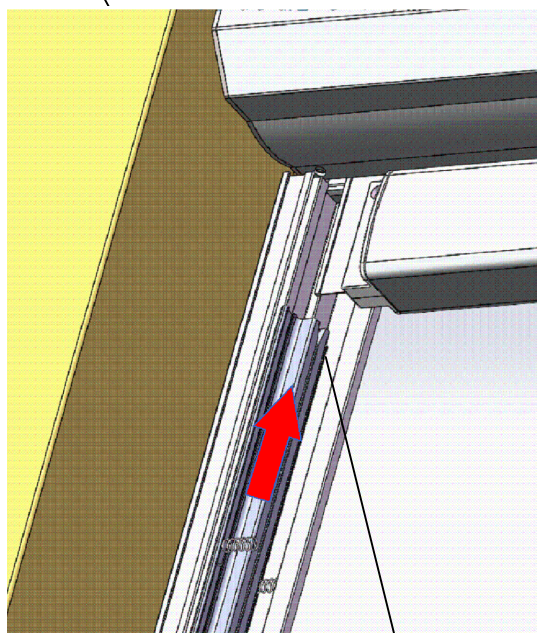

Glissière avec embout biseauté vers le haut



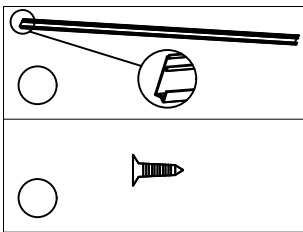

Finaliser en installer la dernière partie du rail, et verrouiller avec les vis (attention à bien positionner les ressorts)

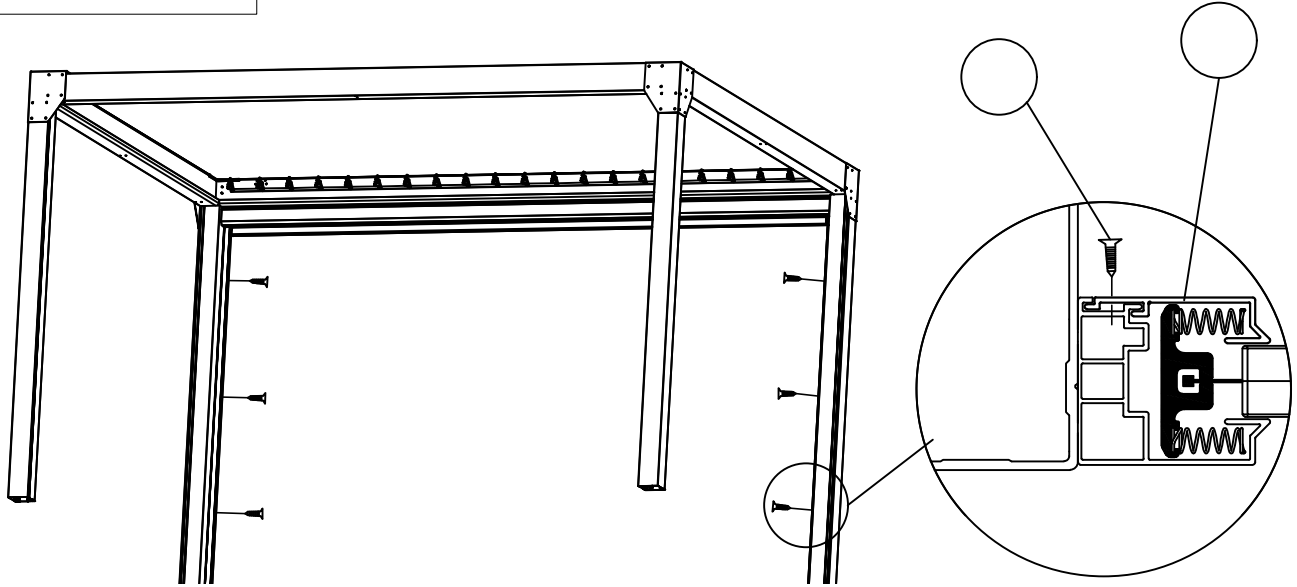

L'installation est terminée, vous pouvez vérifier le bon appairage des canaux

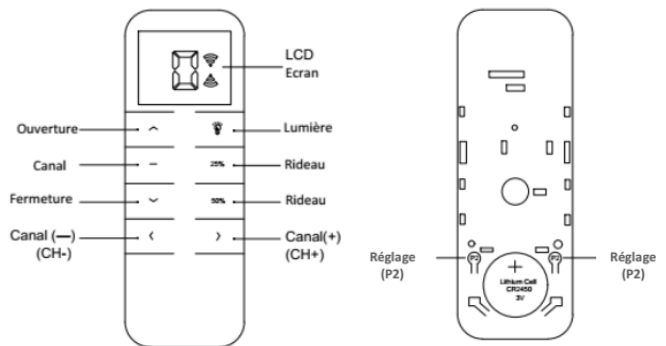
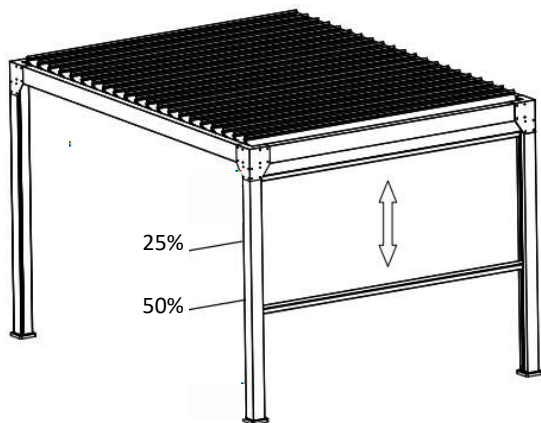

Comment Appairer le rideau motorisé ?

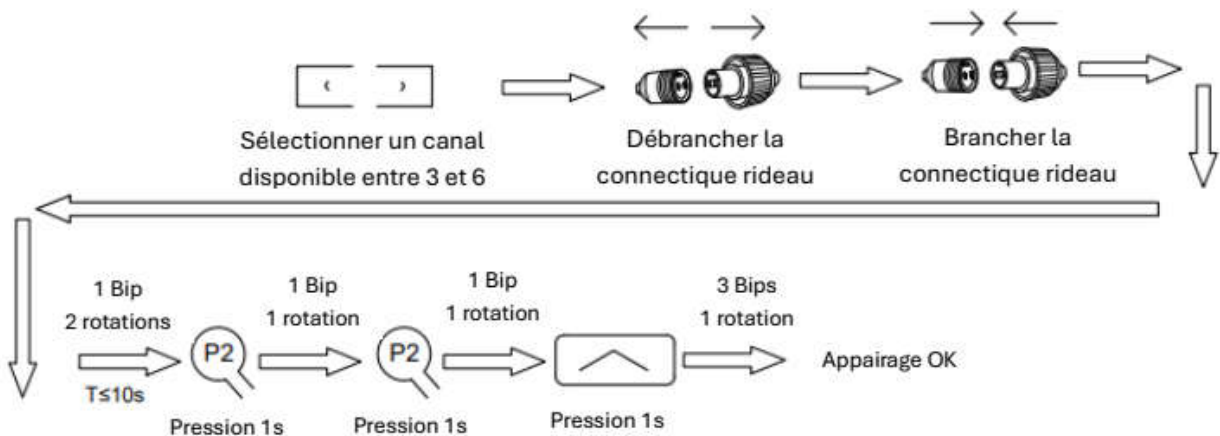

Info : les canaux 0 à 2 sont pré-programmés :

« 0 » contrôle l'ensemble des lames, « 1 » contrôle une partie 3m, « 2 » contrôle l'autre partie 3m
 Les canaux 3 à 6 sont destinés au contrôle des 4 rideaux de la pergola.



Une utilisation continue au delà de 5mn peut déclencher la mise en sécurité. Attendre le refroidissement moteur pour être à nouveau opérationnel.

