

PRODUCT NAME

Disc Grinder

Models 115 mm (4-1/2") G 12SA4, G 12SA4(S)
125 mm (5") G 13SB4, G 13SB4(S)

G

CONTENTS	Page
REPAIR GUIDE	1
1. Precautions on disassembly and reassembly	1
• Disassembly	1
• Reassembly	3
• Lubrication point and type of lubricant	6
• Tightening torque	6
• Insulation test	6
• No-load current value	6
• Wiring diagram	7
STANDARD REPAIR TIME (UNIT) SCHEDULES	8

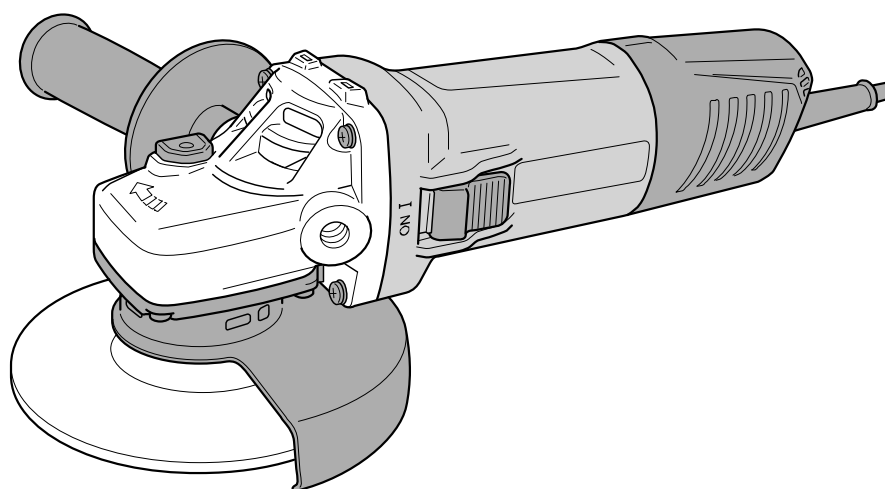

REPAIR GUIDE

WARNING: Before attempting disassembly, be sure to turn off the power switch and disconnect the power cord plug from the outlet.

1. Precautions on disassembly and reassembly

[Bold] numbers in the description below correspond to the item numbers in the parts list and exploded assembly diagram for the Models G 12SA4 and G 12SA4(S), and **<Bold>** numbers to those for the Models G 13SB4 and G 13SB4(S).

Disassembly

1. Removal of the armature and stator

- (1) Loosen the Tapping Screw (W/Flange) D4 x 20 **[51]<51>** and pull out the Tail Cover **[50]<50>**. Remove the Carbon Brushes (1 Pair) **[38]<38>** from the Brush Holders **[36]<36>**.
- (2) Loosen the four Seal Lock Screws (W/Sp. Washer) M4 x 14 **[7]<7>** and remove the Packing Gland **[6]<6>** ass'y and Lever Holder **[8]<8>**.
- (3) Loosen the four Tapping Screws (W/Flange) D4 x 25 **[1]<1>** that fix the Gear Cover **[2]<2>** to remove the Armature **[24]<24>** from the Housing **[34]<34>** together with the Diffuser **[23]<23>**. At this time, check that the Rubber Bushing **[33]<33>** is fitted in the housing ball bearing chamber.
- (4) Carefully wrap the Armature **[24]<24>** with a soft, clean rag to protect it from being damaged, and clamp it securely in a vise. Then remove the Special Nut M7 **[18]<18>** and extract the Gear and Pinion Set **[25]<25>**.
- (5) Disconnect the four internal wires of the Stator **[30]<30>** from the Pushing Button Switch **[40]<40>** and Brush Holders **[36]<36>**.
- (6) Remove the Fan Guide **[29]<29>** and Stator **[30]<30>** from the Housing **[34]<34>**.

NOTE: • If the Stator **[30]<30>** is hard to be removed from the Housing **[34]<34>**, heat the Housing **[34]<34>** up to about 60°C to facilitate removal. Then pull out the Rubber Bushing **[33]<33>**.

- Each internal wire of the Stator **[30]<30>** is covered with a glass tube. Do not bend the internal wires repeatedly and do not peel off the glass tubes when removing the Stator **[30]<30>** from the Housing **[34]<34>**. Otherwise, the internal wires may be disconnected.
- Do not apply excessive force to the terminals of the Stator **[30]<30>** when removing them from the Pushing Button Switch **[40]<40>** and Brush Holders **[36]<36>**. Otherwise, the terminals of the Stator **[30]<30>** may be broken.

2. Removal of the rubber bushing

Insert the special repair tool J-201 spring hook (Code No. 970977) between the Rubber Bushing **[33]<33>** assembled in the Housing **[34]<34>** and the housing ball bearing chamber, and then pull out the Rubber Bushing **[33]<33>**.

3. Removal of the dust seal

- (1) Insert the hooks of the J-204 bearing puller between the Ball Bearing 698SS **[32]<32>** and the Dust Seal **[31]<31>** and fix the hooks with the wing bolts.

NOTE: Be careful not to insert the hooks excessively.

- (2) Put the bearing puller on an appropriate stand. Press down on the armature shaft with a hand press and pull out the Ball Bearing 698SS **[32]<32>**.
- (3) Pull out the Dust Seal **[31]<31>** from the armature shaft.

4. Removal of the gear and spindle

- (1) Loosen the four Seal Lock Screws (W/Sp. Washer) M4 x 14 [7]<7> and remove the Packing Gland [6]<6> from the Gear Cover [2]<2>.
- (2) Remove the Retaining Ring for D12 Shaft [4]<4> that secures the gear to the Spindle [12]<12>.
- (3) When it is necessary to remove the gear from the Spindle [12]<12>, it is highly recommended that the special repair tool J-245-3 sleeve (Code No. 307720) described below is utilized. Place the assembly on a sleeve that matches the dimension of the Packing Gland [6]<6> and press down on the top of the Spindle [12]<12> with a hand press to remove the gear as shown in Fig. 1.

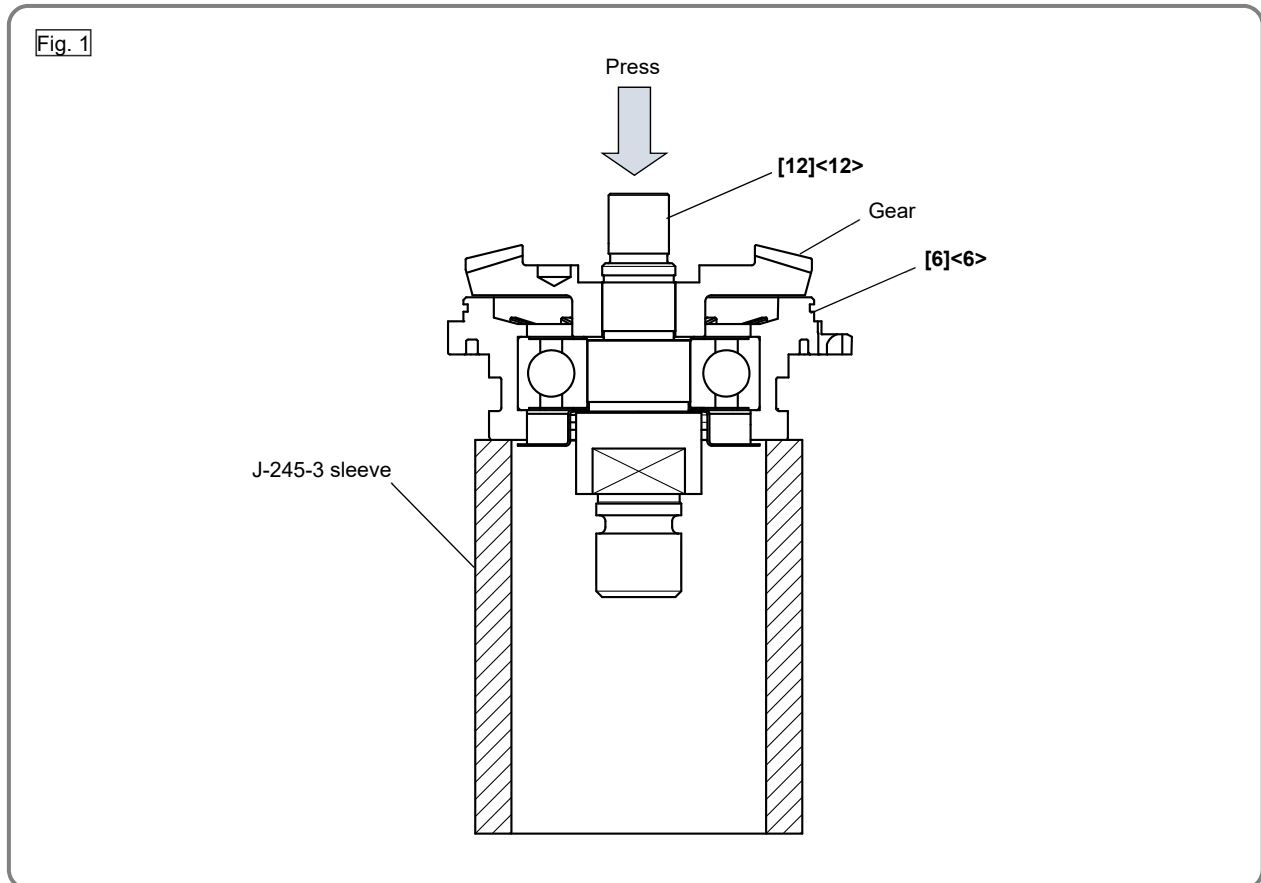

5. Removal of the pushing button switch

- (1) Disconnect the two internal wires of the Stator [30]<30> and two internal wires of the Noise Suppressor [43]<43> from the Pushing Button Switch [40]<40>.
- (2) Remove the Cord [52]<52> from the side rib of the Housing [34]<34>.
- (3) Push the Slide Bar [49]<49> and Slide Knob [47]<47>. Leave a 6-mm gap between the Slide Bar [49]<49> and Housing [34]<34>. Pull the Pushing Button Switch [40]<40> as shown in Fig. 2.
- (4) Remove the Cord [52]<52> from the Pushing Button Switch [40]<40>.

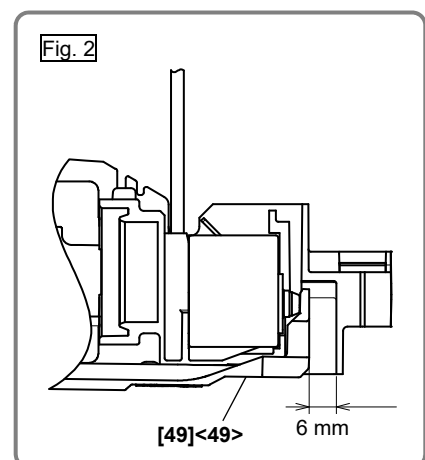

Reassembly

Reverse the disassembly procedure to reassemble. Note the following points.

- (1) Rub grease into the teeth of the Gear and Pinion Set [25]<25> with your fingers so that the grease reaches each tooth bottom. Note that under-lubricated Gear and Pinion Set [25]<25> may wear at a faster rate.
- (2) When replacing the Armature [24]<24> and the Ball Bearing 698SS [32]<32> on the commutator side, press the Dust Seal [31]<31> in while carefully noting its direction until the end face of the Dust Seal [31]<31> contacts the butting surface of the Armature [24]<24>, and check that the Dust Seal [31]<31> cannot turn freely. (See Fig. 3.) The Dust Seal [31]<31> is an important element for improved dust protection of the Ball Bearing 698SS [32]<32>. Be sure to replace the Dust Seal [31]<31> with new one at every disassembly work. Fit the Rubber Bushing [33]<33> into the housing ball bearing chamber before installing the Armature [24]<24>. (See Fig. 4.)

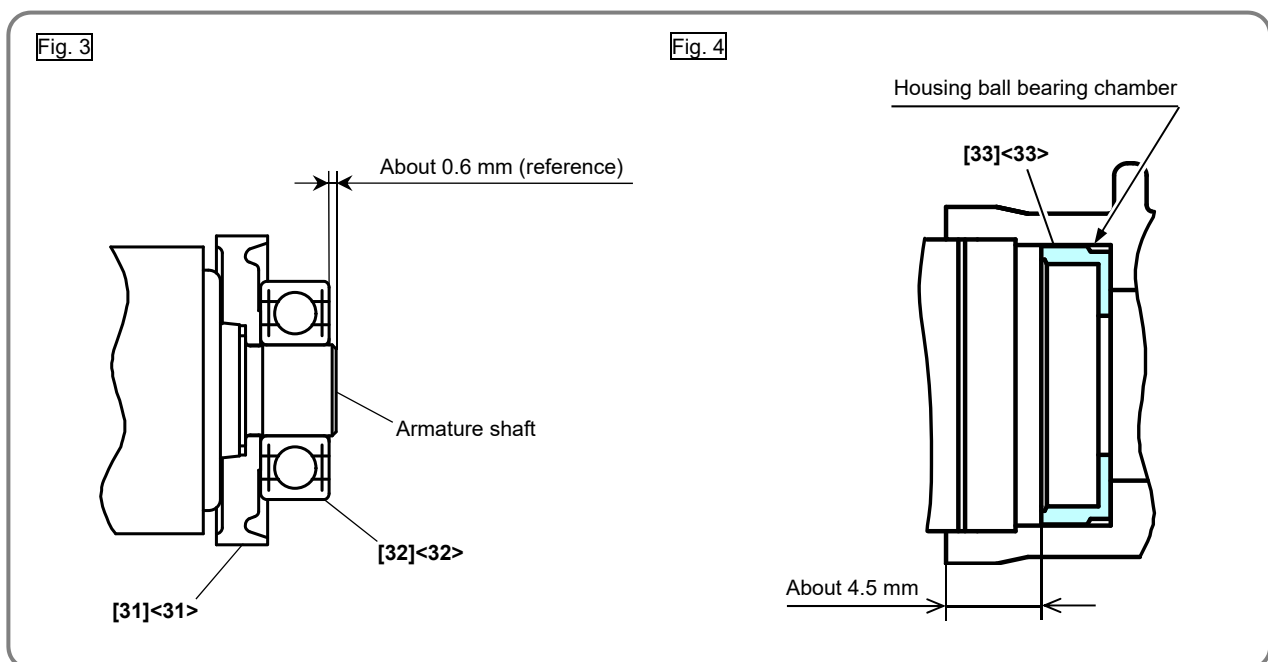

- (3) When installing the Stator [30]<30> into the Housing [34]<34>, insert it while being careful about correctly placing the internal wires of the Stator [30]<30> as shown in Fig. 5. Connect the four internal wires of the Stator [30]<30> correctly as shown in Fig. 6.

NOTE: • Be careful not to put the internal wire of the Carbon Brush (1 Pair) [38]<38> on the top of the Brush Holders [36]<36> when connecting the internal wires of the Stator [30]<30> or when connecting the Carbon Brush (1 Pair) [38]<38>.

- Each internal wire of the Stator [30]<30> is covered with a glass tube. Do not bend the internal wires repeatedly and do not peel off the glass tubes when mounting the Stator [30]<30> to the Housing [34]<34>. Otherwise, the internal wires may be disconnected.
- Do not apply excessive force to the terminals of the Stator [30]<30> when inserting them into the Pushing Button Switch [40]<40> and Brush Holders [36]<36>. Otherwise, the terminals of the Stator [30]<30> may be broken.

Fig. 5

Connect to the Brush Holder [36]<36>.

Connect to the Pushing Button Switch [40]<40>.

Connect to the Pushing Button Switch [40]<40>.

Connect to the Brush Holder [36]<36>.

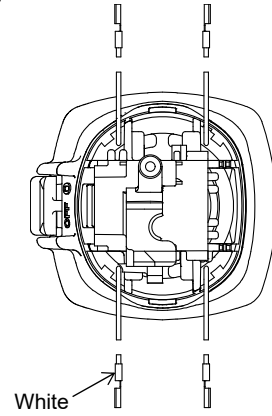
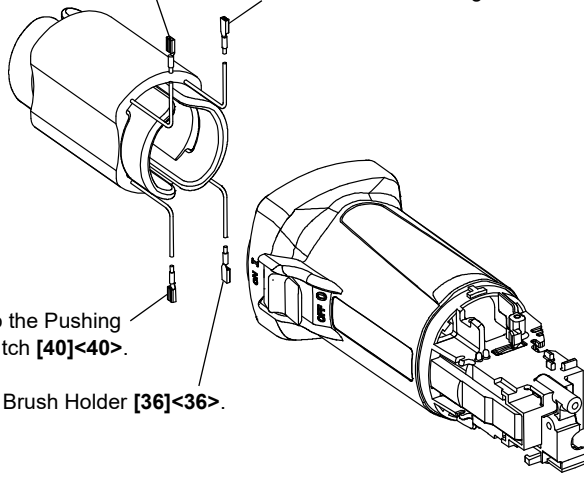
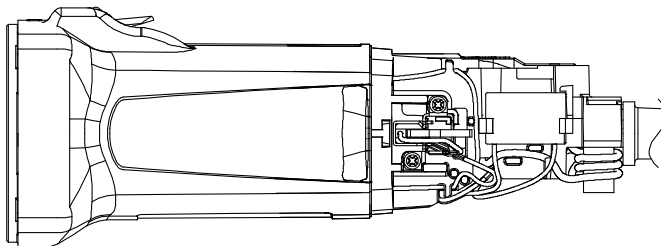
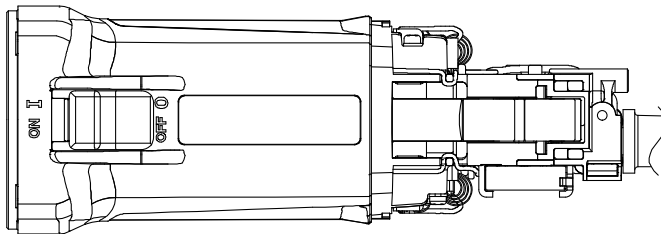
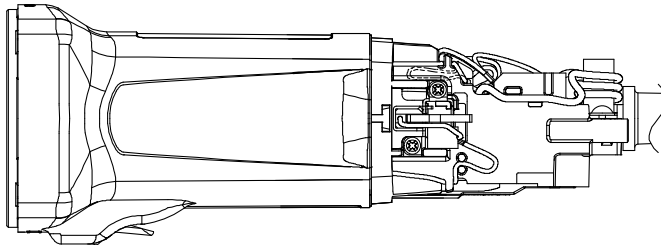
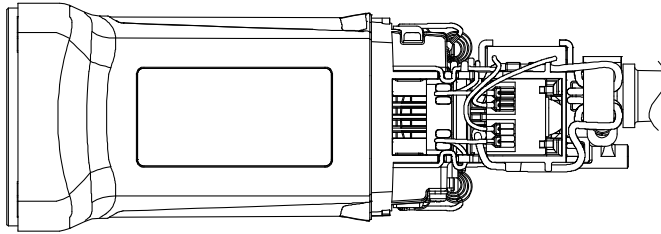
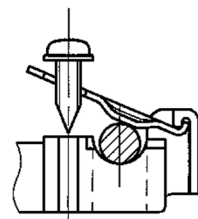

Fig. 6



Direction of the cord clip



- (4) Be sure to soak the inner diameter of the Felt Packing [9]<9> with machine oil. Otherwise, its dust sealing function will fail to work properly, resulting in premature damage to the ball bearing of the Packing Gland [6]<6>. Wipe the Felt Packing [9]<9> lightly with a rag before assembling.
- (5) Mount the Fan Guide [29]<29> in proper direction by matching the gate mark of the Fan Guide [29]<29> with the "N" mark of the Housing [34]<34> as show in Fig. 7.

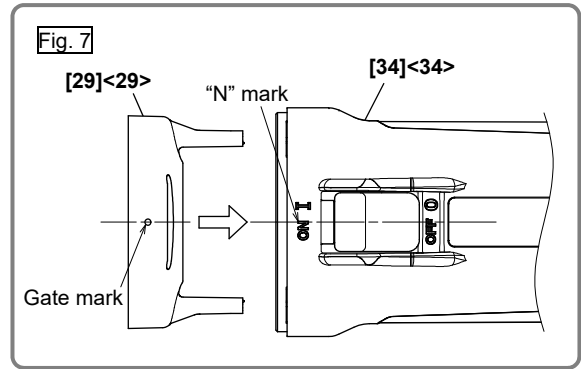

- (6) Do not catch the pigtail of the Carbon Brush (1 Pair) [38]<38> in the Tail Cover [50]<50> when mounting the Tail Cover [50]<50>. Check that the pigtail is in its proper position as shown in Fig. 8 before mounting the Tail Cover [50]<50>.

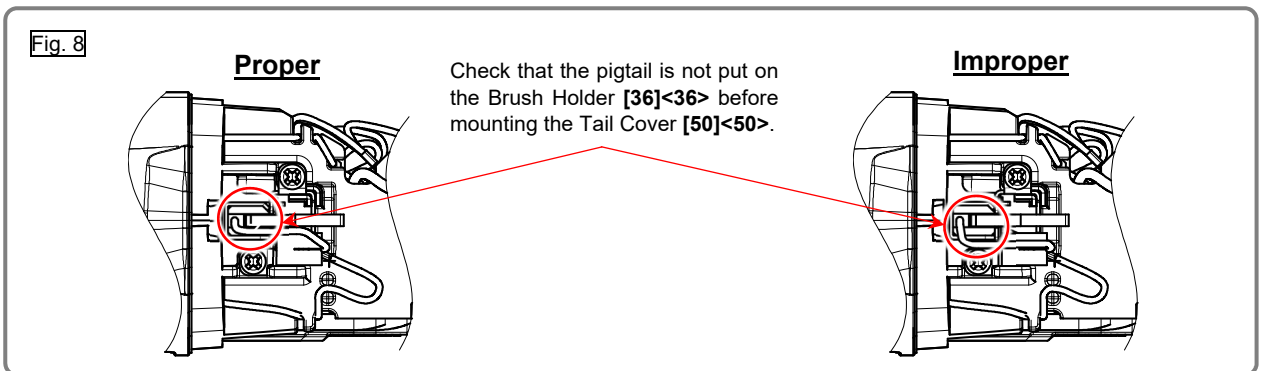

- (7) Tighten three of the four Seal Lock Screws (W/Sp. Washer) M4 x 14 [7]<7> except the one for securing the Lever Holder [8]<8>. Mount the Lever [27]<27> and Retaining Ring D4 [28]<28> to the Lever Holder [8]<8>. Hook the Spring [26]<26> on the Lever [27]<27>. Then tighten the remaining Seal Lock Screw (W/Sp. Washer) M4 x 14 [7]<7>.

- (8) Mount the Pushing Button Switch [40]<40> according to the following steps.

- Attach the Cord [52]<52> to the Pushing Button Switch [40]<40>.
- Mount the Pushing Button Switch [40]<40> while pressing the pressing point of the Pushing Button Switch [40]<40> as shown in Fig. 9.
- Mount the Ferrite Core [42]<42> and Cord [52]<52> as shown in Fig. 10.

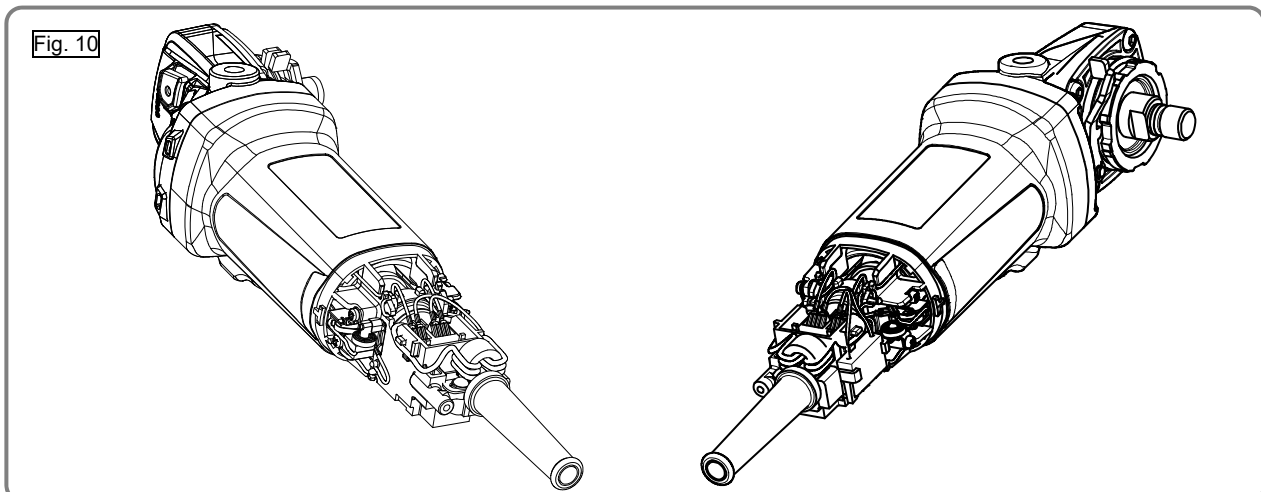
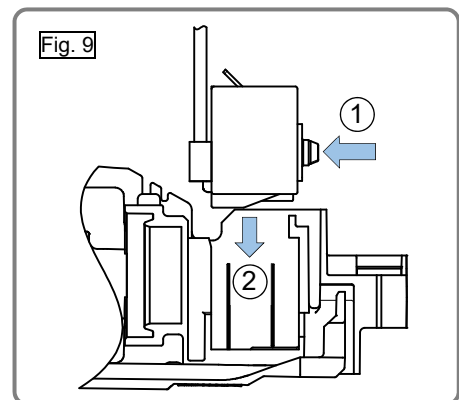

Lubrication point and type of lubricant

NOTE: Use a brush when rubbing grease.

- (1) When replacing the Gear Cover [2]<2>, lubricate the inner circumference of the needle bearing with 0.3 g of Cosmo Molybdenum No. 1 grease.
- (2) Rub 18 g of Cosmo Molybdenum No. 1 grease into the pinion chamber of the Gear Cover [2]<2>.
- (3) Rub 2 g of Cosmo Molybdenum No. 1 grease into the teeth of the gear.
- (4) Rub 0.7 g of Cosmo Molybdenum No. 1 grease into the teeth of the pinion.

Tightening torque

Item No.	Part name	Tightening torque		
		N•m	lbf•ft	kgf•cm
[18]<18>	Special Nut M7	7.4 ± 0.5	5.5 ± 0.4	75 ± 5
[7]<7>	Seal Lock Screw (W/Sp. Washer) M4 x 14	1.8 ± 0.4	1.3 ± 0.3	18 ± 4
[39]<39>	Tapping Screw D3 x 8	0.74 - ⁰ / _{0.25}	0.54 - ⁰ / _{0.18}	7.5 - ⁰ / _{2.5}
[46]<46>	Tapping Screw (W/Flange) D4 x 12	2.0 ± 0.5	1.5 ± 0.4	20 ± 5
[51]<51>	Tapping Screw (W/Flange) D4 x 20 (Black)	2.0 ± 0.5	1.5 ± 0.4	20 ± 5

Insulation test

Measure the insulation resistance and dielectric strength after reassembly.

- Insulation resistance: 7 MΩ or higher (as measured with a 500 VDC megohm tester)
- Dielectric strength: 4,000 VAC/minute, with no abnormalities ----- 230 V to 240 V
2,500 VAC/minute, with no abnormalities ----- 120 V

No-load current value

After no-load operation for 30 minutes, the no-load current values should be as follows.

Voltage	120 V	230 V	240 V
Current max.	5.0 A	2.5 A	2.5 A

Wiring diagram

Fig. 10

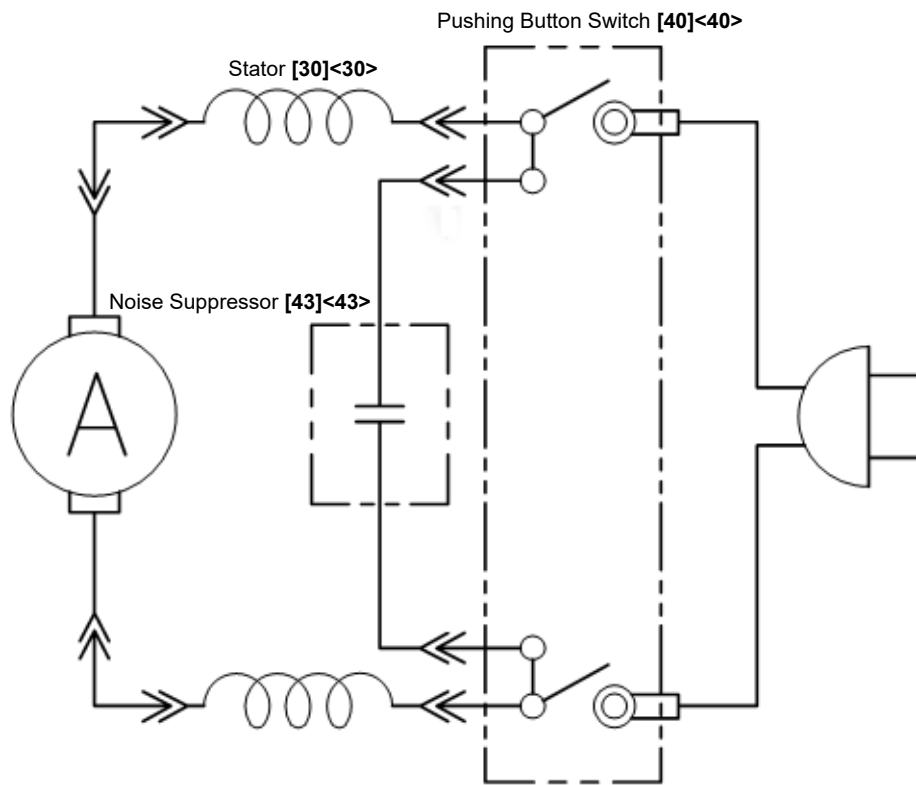

STANDARD REPAIR TIME (UNIT) SCHEDULES

Model	Repair time	10	20	30	40	50	60 min.
<div style="border: 1px solid black; padding: 2px; display: inline-block; margin-bottom: 5px;">G 12SA4</div> <div style="border: 1px solid black; padding: 2px; display: inline-block;">G 13SB4</div>		Work Flow Housing Stator Slide Bar Slide Switch Knob Rubber Bushing	Pushing Button Switch Tail Cover Cord Cord Armor Ferrite Core	Brush Holder Noise Suppressor Cord Clip	Gear Cover Seal Ring (A) Washer (C) Ball Bearing 629VV Retaining Ring for D26 Hole Lock Pin Pushing Button Diffuser	Armature Dust Seal Ball Bearing 698SS Special Nut M7 Pinion (Gear and Pinion Set)	Packing Gland Spindle Felt Packing Fringer Gear (Gear and Pinion Set) Retaining Ring for D12 Shaft O-ring Lever Holder Lever Spring Retaining Ring D4

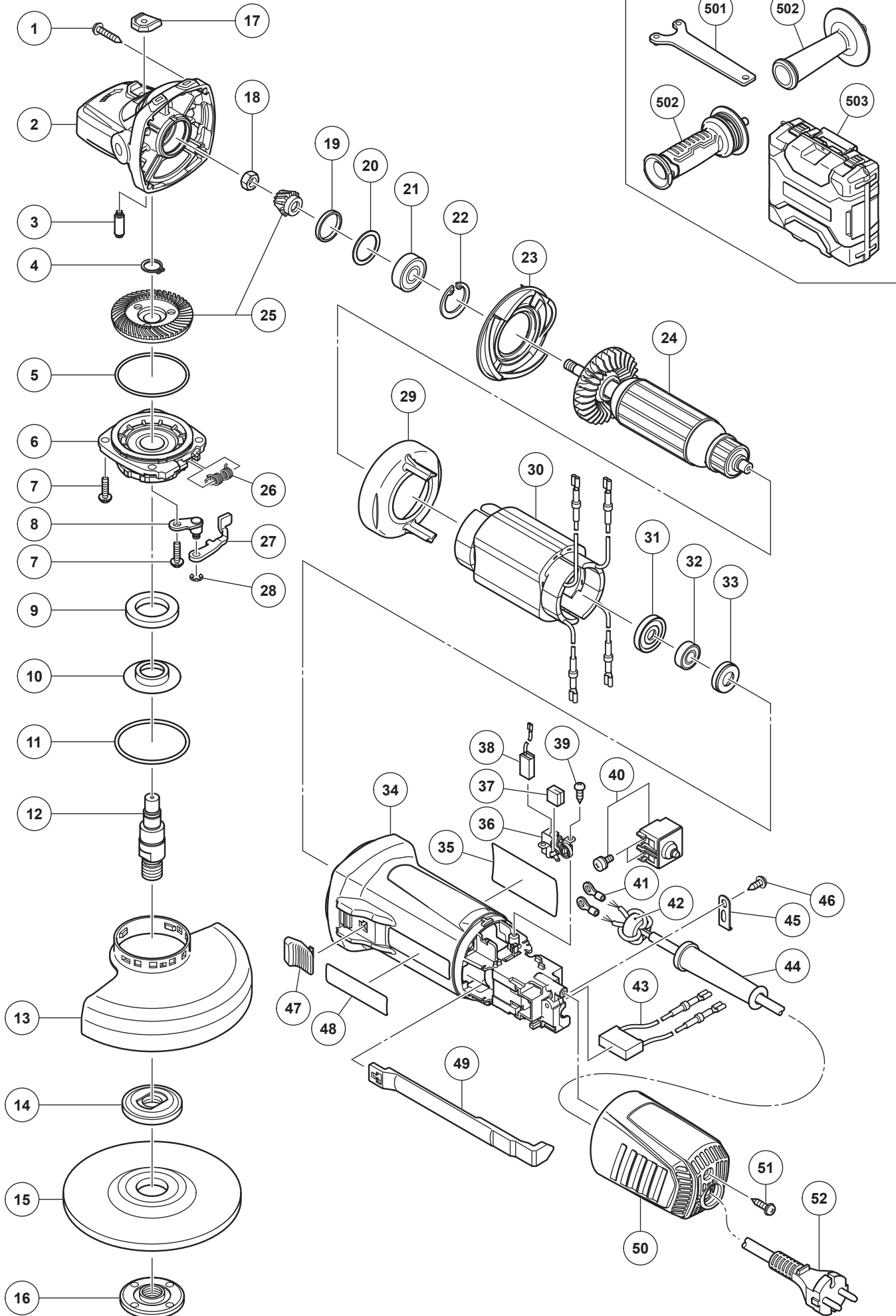

MODEL
G13SB4

ITEM NO.	CODE NO.	DESCRIPTION	NO. USED	REMARKS
1	307028	TAPPING SCREW (W/FLANGE) D4 X 25 (BLACK)	4	
2	375889	GEAR COVER	1	
3	301943	LOCK PIN	1	
4	939542	RETAINING RING FOR D12 SHAFT (10 PCS.)	1	
5	375899	O-RING	1	
6	375887	PACKING GLAND	1	
7	376226	SEAL LOCK SCREW (W/SP. WASHER) M4 X 14	4	
8	375894	LEVER HOLDER	1	
9	376227	FELT PACKING	1	
10	376228	FRINGER	1	
11	375900	O-RING	1	
12	375895	SPINDLE	1	
13	375904	WHEEL GUARD	1	
14	376067	WHEEL WASHER	1	
15	316822	D. C. WHEELS 125MM A36Q (25 PCS.)	1	
16	339579	WHEEL NUT M14	1	
17	336535	PUSHING BUTTON	1	
18	301941	SPECIAL NUT M7	1	
19	308543	SEAL RING (A)	1	
20	980866	WASHER (C)	1	
21	629VVM	BALL BEARING 629VV	1	
22	939554	RETAINING RING FOR D26 HOLE (10 PCS.)	1	
23	336542	DIFFUSER	1	
*24	361131E	ARMATURE 230V	1	
*24	361131F	ARMATURE 240V	1	
25	375888	GEAR AND PINION SET	1	
26	376229	SPRING	1	
27	375892	LEVER	1	
28	6685336	RETAINING RING D4	1	
29	336530	FAN GUIDE	1	
30	341070F	STATOR 230 V-240 V	1	
31	336536	DUST SEAL	1	
32	336871	BALL BEARING 698SS	1	
33	309929	RUBBER BUSHING	1	
34	375878	HOUSING	1	
35		NAME PLATE	1	
36	336537	BRUSH HOLDER	2	
37	336872	CUSHION SPONGE	2	
38	999088	CARBON BRUSH (1 PAIR)	2	
39	328210	TAPPING SCREW D3 X 8	4	
*40	376232	PUSHING BUTTON SWITCH	1	
*40	376230	PUSHING BUTTON SWITCH	1	FOR GBR, EUROPE(S)
41	980063	TERMINAL	2	
42	334379	FERRITE CORE	1	
43	375898	NOISE SUPPRESSOR	1	
44	953327	CORD ARMOR D8.8	1	
45	937631	CORD CLIP	1	
46	305720	TAPPING SCREW (W/FLANGE) D4 X 12	1	
47	314428	SLIDE KNOB	1	
48		BRAND LABEL	1	
49	375882	SLIDE BAR	1	
50	370047	TAIL COVER	1	
51	301653	TAPPING SCREW (W/FLANGE) D4 X 20 (BLACK)	1	
*52	500247Z	CORD	1	
*52	500435Z	CORD	1	FOR GBR, UAE
*52	500234Z	CORD	1	FOR RUS, IND
*52	500439Z	CORD	1	FOR AUS, NZL
STANDARD ACCESSORIES				
501	938332Z	WRENCH	1	
*502	994322	SIDE HANDLE	1	
*502	336865	SIDE HANDLE	1	FOR VIBRATION-ABSORBING
503	376233	CASE	1	