

PRODUCT NAME

Rotary Hammer

Models DH 24PMH
 DH 26PMC
 DH 26PMX

D

CONTENTS

Page

REPAIR GUIDE -----	1
1. Precautions on disassembly and reassembly-----	1
• Disassembly-----	1
• Reassembly-----	5
• Lubrication points and type of lubricant-----	12
• Tightening torque-----	15
• Insulation test-----	15
• No-load current value-----	15
• Connecting diagram-----	16
• Switch-related wiring-----	16
• Wiring diagram-----	18

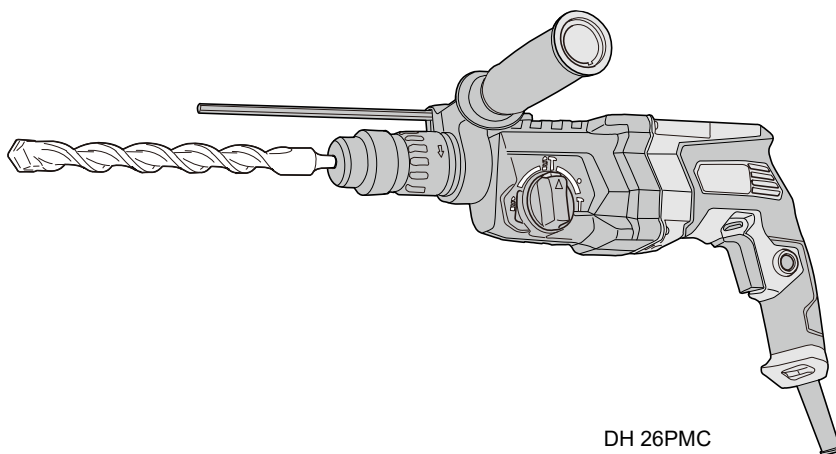

DH 26PMC

REPAIR GUIDE

WARNING: Be sure to disconnect the power cord plug from the wall outlet before conducting repair. Otherwise, the motor may run suddenly and you could get injured.

1. Precautions on disassembly and reassembly

(**Bold**) numbers in the description below correspond to the item numbers in the parts list and exploded assembly diagram for the Model DH 24PMH, **{Bold}** numbers to those for the Model DH 26PMC, and **<Bold>** numbers to those for the Model DH 26PMX. **[Bold]** numbers are common to all three models.

Disassembly

1. Disassembly of the tool retainer ass'y

(1) Disassembly of the tool retainer ass'y

- Fully pull the Grip **[19]** in the arrow direction and detach the Front Cap **[17]**.
- Using a retaining ring puller, remove the Stopper Ring **[18]** while pulling the Grip **[19]** in the arrow direction.
- Detach the Grip **[19]**, Ball Holder **[20]**, Steel Ball D7.0 **[11]**, Holder Plate **[21]**, and Holder Spring **[22]** from Bit Holder (A) **[23]**.

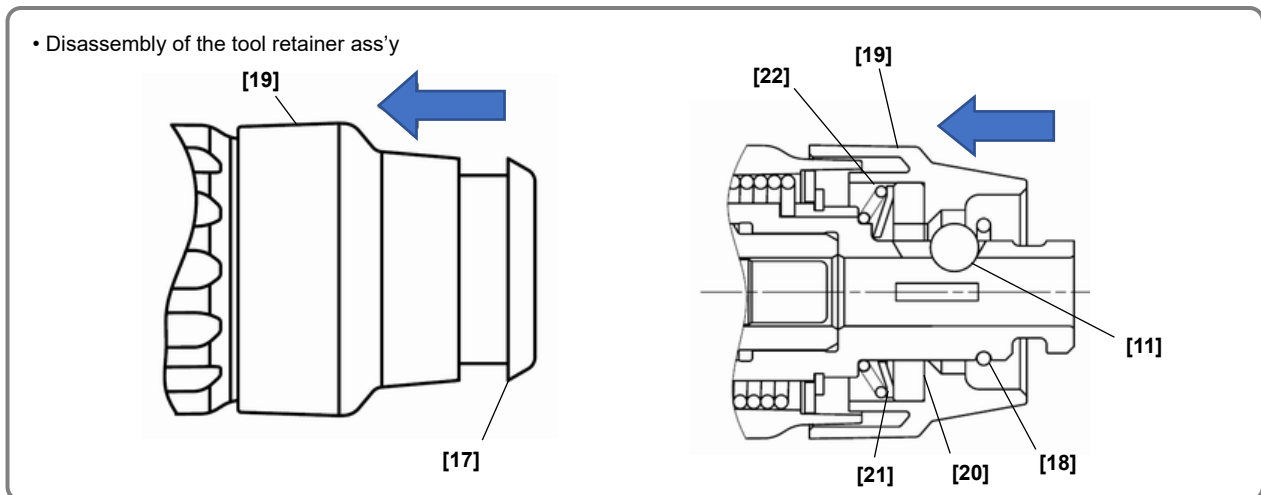

(2) Disassembly of bit holder (A) ass'y

- Remove the parts around the grip and the Retaining Ring for D25 Shaft **[5]**.
- Remove Washer (B) **[6]**, Spring **[7]**, Lock Grip **[8]**, Lock Ring **[9]**, and Steel Ball D7.0 **[11]** from Bit Holder (A) **[23]**.

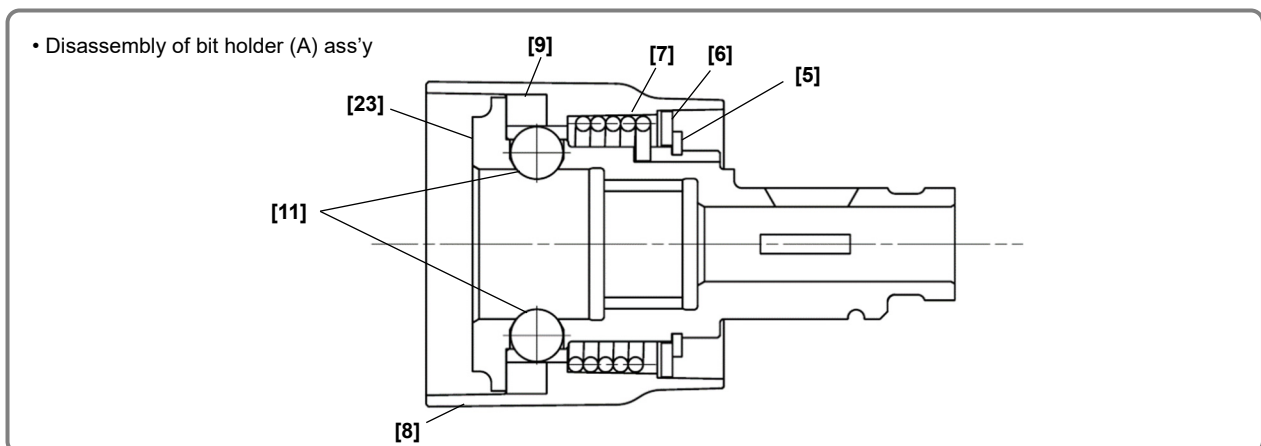

(3) Disassembly of chuck holder (A) ass'y

- Engage the J-345 chuck holder jig (Code No. 327062) with the spline as shown in the figure below.
- Hold the width-across-flats portion in a vise and remove Flat Hd. Screw (A) (Left Hand) M6 x 25 [2].
- Put a hexagonal bar in the Drill Chuck 13VLRU-N (W/O Chuck Wrench) [3] then loosen and remove it using a torque wrench.
- Remove the Stopper [4]. Then Chuck Holder (A) [10] can be removed in the same manner as the disassembly of bit holder (A) ass'y.

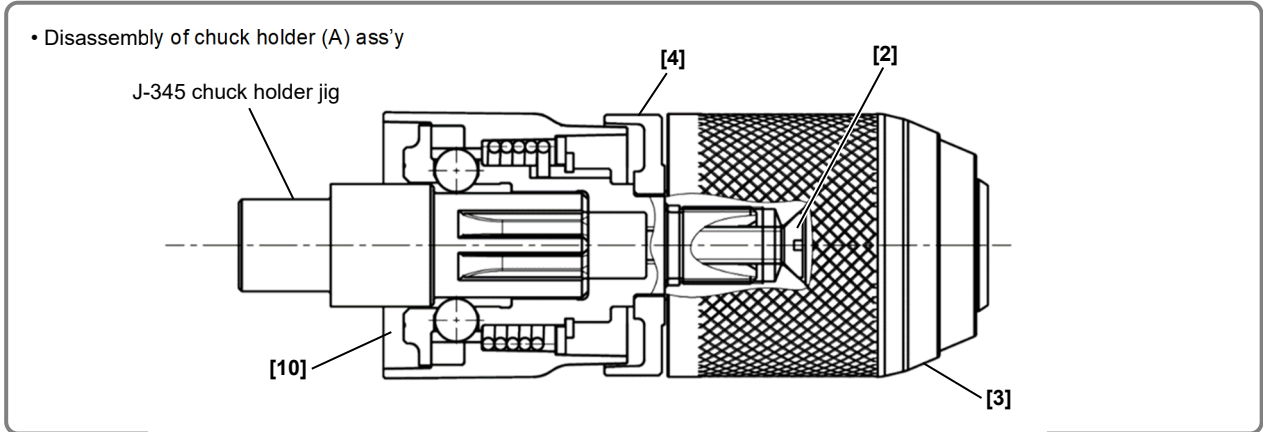

2. Removal of the change lever

- Push in the Pushing Button [24] at the "Hammering only" (T mark) position.
- Turn the Change Lever [26] counterclockwise a little, and then fully push in the Pushing Button [24].
- In this state, turn the Change Lever [26] clockwise. When the Change Lever [26] stops, release the Pushing Button [24] so that the Pushing Button [24] protrudes from the Change Lever [26] and then turn the Change Lever [26] clockwise until it stops.

NOTE: If the Pushing Button [24] does not protrude from the Change Lever [26], hold the Change Lever [26] and move it from side to side slightly.

- Fully push in the Pushing Button [24] and turn the Change Lever [26] clockwise until it stops. At this position, pry the Change Lever [26] off.

NOTE: Be careful not to let the Pushing Button [24] pop out.

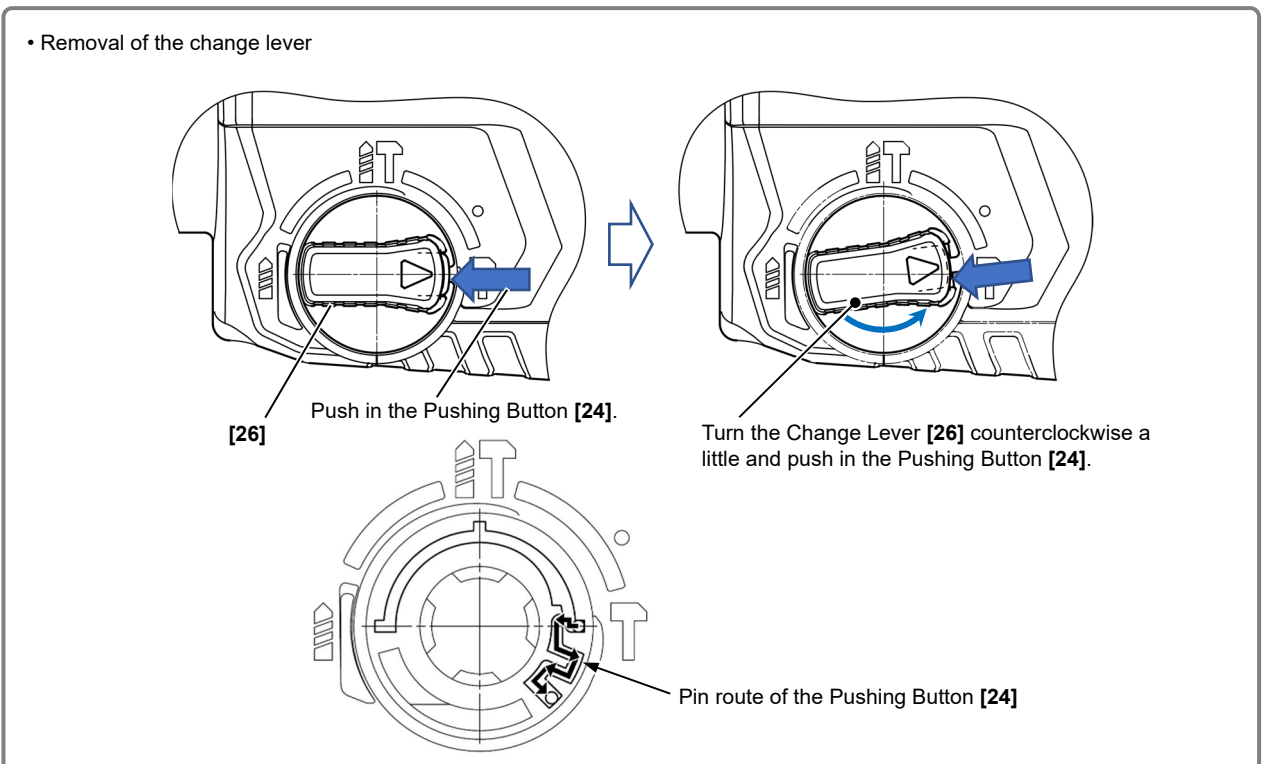

3. Disassembly of the hammering mechanism

- Use a drill bit or screwdriver to push the Second Hammer [39] into the front end, and then remove the Striker [45] that is chucked by O-ring (C) [42].
- Remove the Tapping Screw (W/Flange) D5 x 35 (81){81}<79> from housing (B) and then detach the Gear Cover Ass'y [28].

NOTE: Do not let the Inner Cover [61] come off housing (B).

- After removing the Gear Cover Ass'y [28], Spring (E) [29] and Shaft Holder (B) [31] remain at the Gear Cover Ass'y [28] side.
- Remove the Lock Plate [50] ass'y from the Second Shaft [56] and rotate the inner ring of the Reciprocating Bearing [57] to allow the Piston [47] to reach the top dead point (towards the Inner Cover [61]). The arm of the Reciprocating Bearing [57] comes off the Piston Pin [48] and the Bearing Washer [59] and the parts on the Second Shaft [56] come off together from the Inner Cover [61].

NOTE: Do not lose the Bearing Washer [59].

- Place the end face of the Reciprocating Bearing [57] on a cradle as shown in the figure below. Push the rear end of the Second Shaft [56] with a hand press to push out the First Gear [58] and Reciprocating Bearing [57] from the Second Shaft [56]. Note that the First Gear [58] is press-fitted to the end of the 9 mm dia. shaft of the Second Shaft [56] for alignment.

- Lock plate ass'y

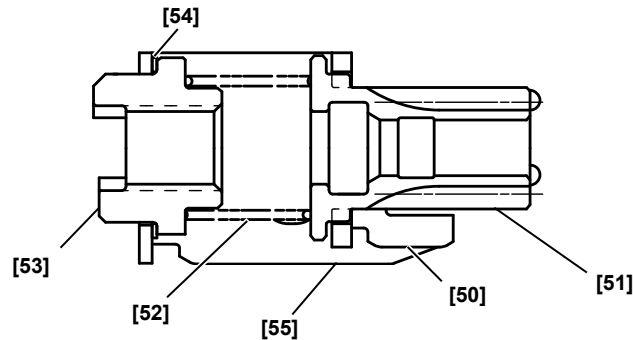

- Removal of the second shaft

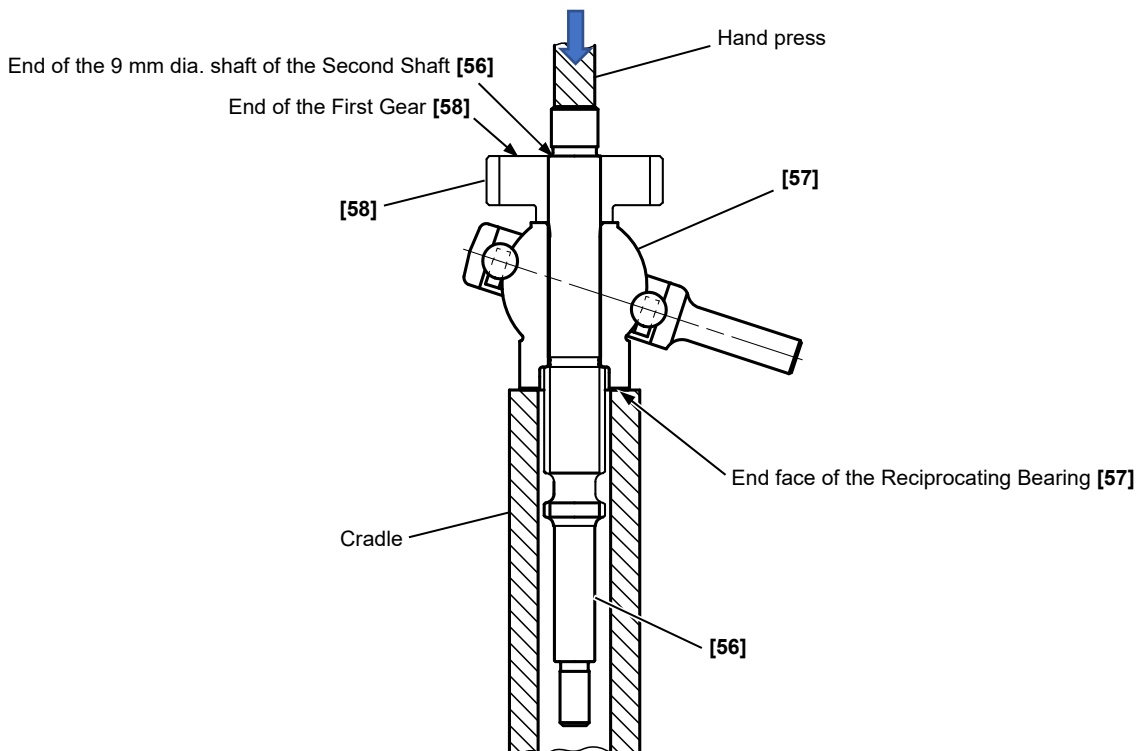

4. Disassembly of the cylinder ass'y

(1) Disassembly of the slip clutch ass'y

- Remove Bit Holder (A) Ass'y [15] or Chuck Holder Ass'y [1] and pull out the Cylinder [32] ass'y from the Gear Cover Ass'y [28].
- Remove Washer (A) [35] from the Cylinder [32] and use a retaining ring puller to pull out the Retaining Ring for D30 Shaft [36]. Then remove Washer (A) [35], Spring (B) [34], and Second Gear [33] from the Cylinder [32].

NOTE: Be careful not to let the Retaining Ring for D30 Shaft [36] and Washer (A) [35] pop out.

(2) Removal of the parts from the inside of the cylinder

- Use the special repair tools specified in the table for removal of the parts from the inside of the Cylinder [32].

Special repair tool		Code No.
J-341	Stopper ring jig (A)	324202
	Ring puller jig (B)	324203
	Punch (C)	324204

- Insert the non-hole side of J-341 stopper ring jig (A) into the Cylinder [32] as shown in the figure

below until it contacts the end of the Damper Holder [43]. Clamp the ends of a jig supporting the Cylinder [32] and J-341 stopper ring jig (A) with a vise to compress Damper (A) [41]. (Push the Stopper Ring [44] with J-341 punch (C) and make sure it moves a little.)

- In this state, insert J-341 punch (C) into each of the two 8 mm dia. holes on the Cylinder [32]. Hammer the punch head to give force to the periphery of the Stopper Ring [44] in order to detach the ring from the bore groove of the Cylinder [32]. Fully hammer along the periphery of the Stopper Ring [44] until the Stopper Ring [44] disappears from the two 8 mm dia. holes.
- Unclamp the Cylinder [32] from the vise and use J-341 ring puller jig (B) to pull out the Stopper Ring [44] from the inner circumference of the Cylinder [32].

NOTE: Be careful not to let the Stopper Ring [44] pop out.

- Once the Stopper Ring [44] is detached from the Cylinder [32], the Second Hammer [39], Hammer Holder (A) [40], Hammer Holder (D) [38], Damper (A) [41], O-ring (C) [42], and the Damper Holder [43] can be removed from the Cylinder [32].

NOTE: The Stopper Ring [44] is deformed by disassembly and must be replaced with a new one when reassembled. Replace O-ring (C) [42] with a new one at each disassembly to prevent idle-hammering.

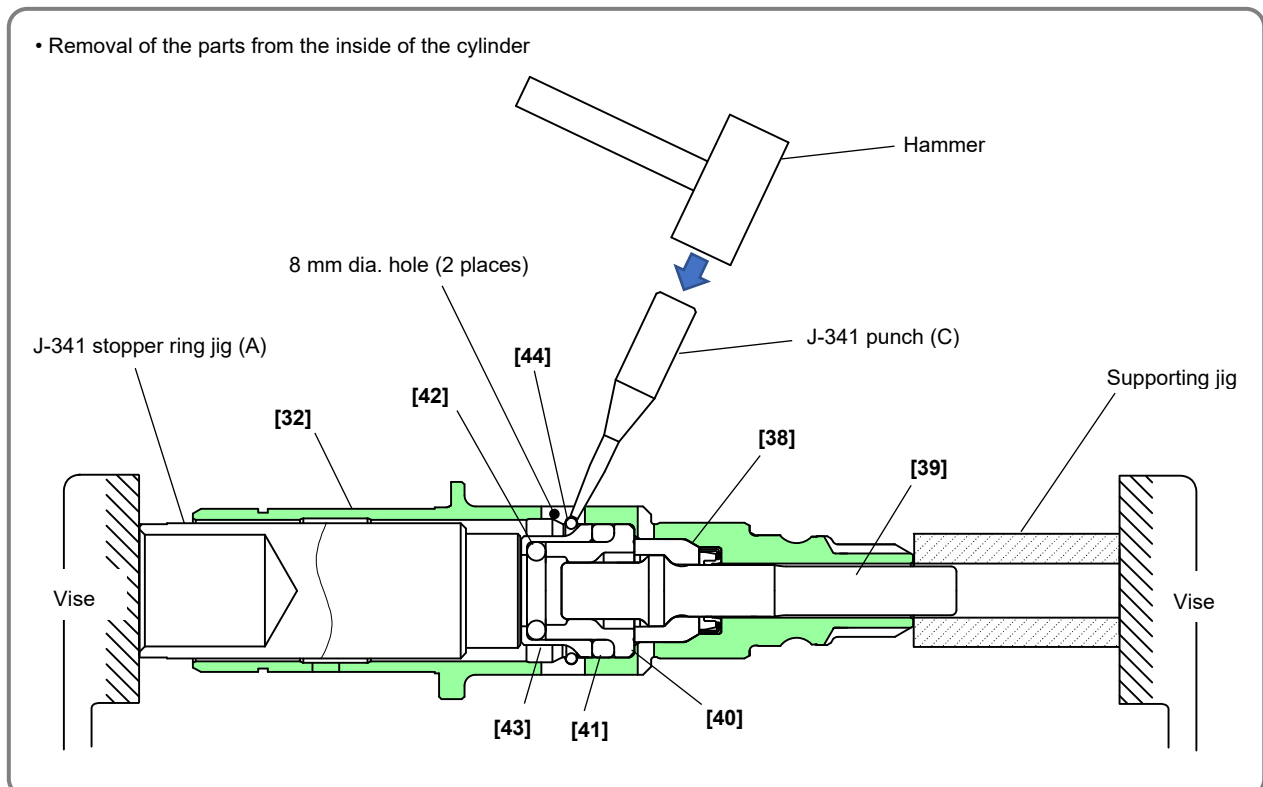

- To remove Oil Seal (A) [37] from the Cylinder [32], insert an L-shaped jig between Oil Seal (A) [37] and Cylinder [32] and push it backward.

NOTE: Oil Seal (A) [37] is deformed by disassembly and must be replaced with a new one when reassembled.

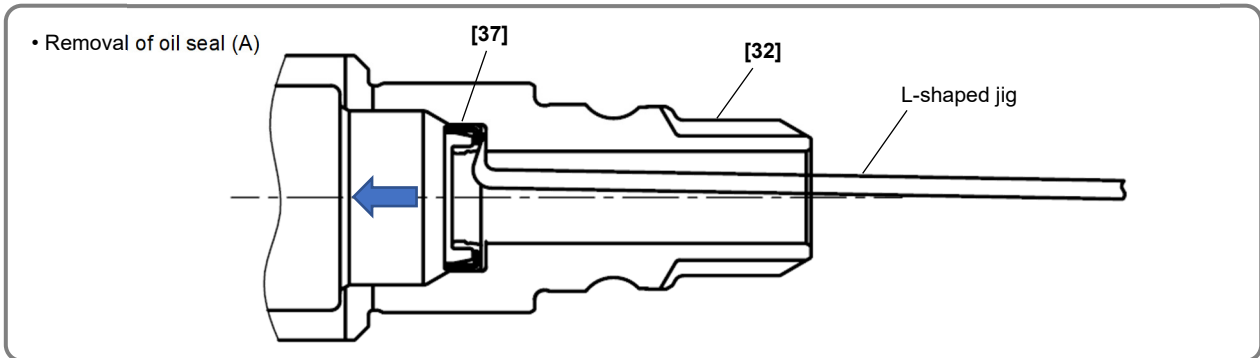

Reassembly

Reassembly can generally be conducted by reversing the disassembly procedure. However, special attention should be given to the following items.

NOTE: The retaining rings, stopper rings, and oil seals are deformed by disassembly and must be replaced with new ones when reassembled.

1. Mounting the oil seals

When mounting the Oil Seal [13] and Oil Seal (A) [37], apply grease to the inner circumferences of both seals, but do not apply grease along their peripheries. Be careful not to skew the Oil Seal [13] and Oil Seal (A) [37] when press-fitting these parts.

2. Reassembly of the cylinder ass'y

- Use the J-341 stopper ring jig (A) (Code No. 324202) for reassembly of the cylinder ass'y.
- Press-fit Oil Seal (A) [37] into the Cylinder [32].

NOTE: Do not reverse the orientation of Oil Seal (A) [37].

- Insert the set of Hammer Holder (D) [38], Second Hammer [39], Hammer Holder (A) [40], Damper (A) [41], O-ring (C) [42], and Damper Holder [43] into the Cylinder [32] as shown in the figure below.

NOTE: Assemble with the outside slope of Hammer Holder (D) [38] set at the front end as shown in the figure below. Be careful of the assembling order.

- Push a new Stopper Ring [44] into the Cylinder [32] with the break of the Stopper Ring [44] facing away from the 8 mm dia. holes on the Cylinder [32] as shown in the figure below. If the Stopper Ring [44] is mounted with the ring break aligning with the 8 mm dia. holes, it becomes difficult to disassemble the cylinder ass'y.
- Insert the hole side of J-341 stopper ring jig (A) into the Cylinder [32]. Use a hand press to press against the upper end of the jig until the Stopper Ring [44] is fitted into the bore groove of the Cylinder [32].
- Check that the Stopper Ring [44] is fitted securely into the bore groove of the Cylinder [32] through the two 8 mm dia. holes on the periphery of the Cylinder [32].

• Reassembly of the cylinder ass'y

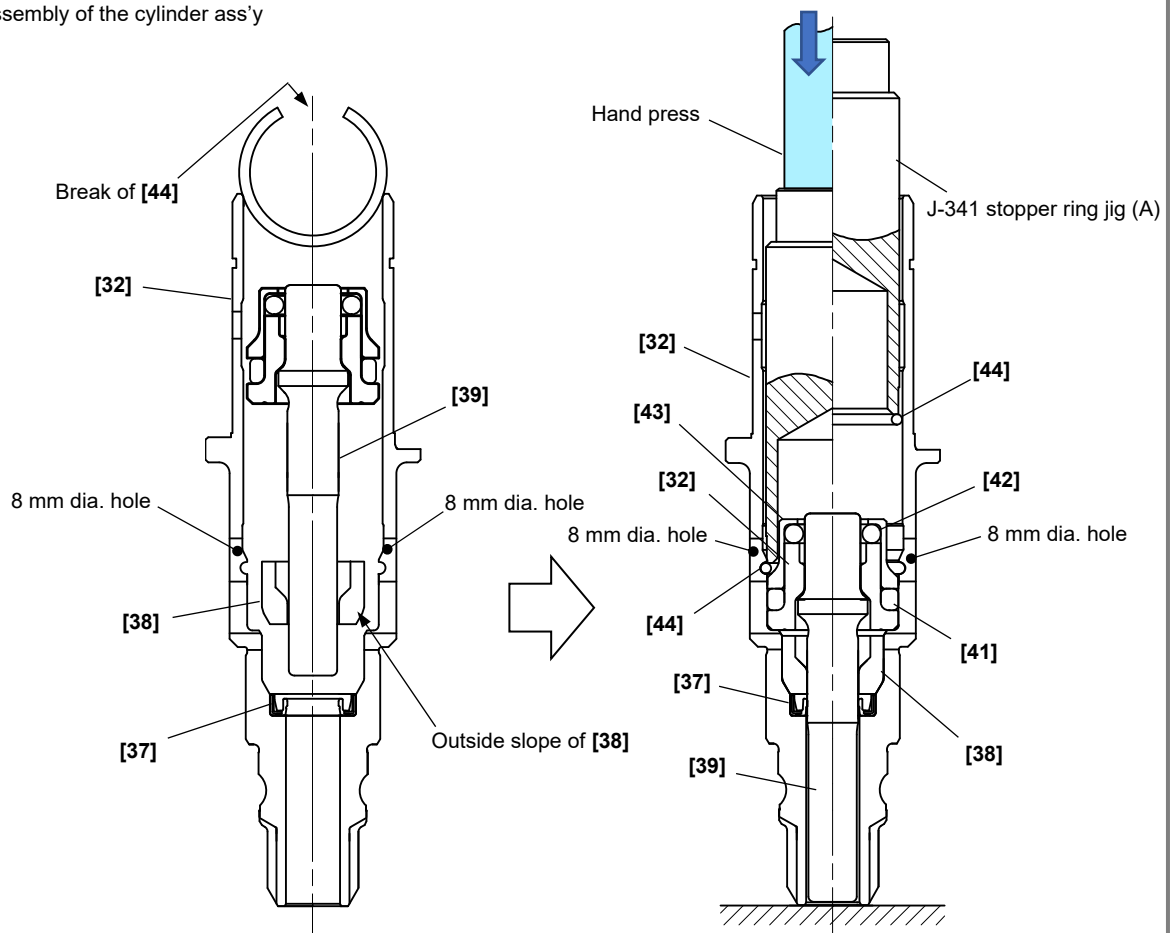

3. Press-fitting the first gear

Press-fit the First Gear [58] so that the end of the First Gear [58] aligns with the rear end of the 9 mm dia. shaft of the Second Shaft [56]. After press-fitting the First Gear [58], check that the inner ring of the Reciprocating Bearing [57] rotates smoothly.

4. Reassembly of the internal pressure adjusting mechanism

Insert Felt Packing (A) [63] into the hole on the Air Cap [62] and put the Air Cap [62] over the 8.6 mm dia. shaft of the Inner Cover [61]. Fit the boss inside the Air Cap [62] hole in the groove on the 8.6 mm dia. shaft of the Inner Cover [61].

• Reassembly of the internal pressure adjusting mechanism

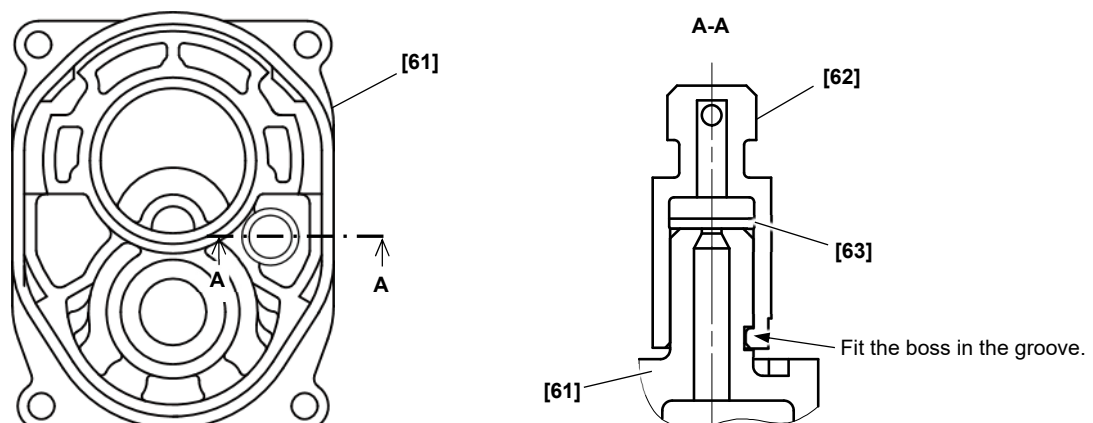

5. Mounting the piston

Mount the Piston [47] as shown in the figure below.

- Apply the specified grease to the inner and outer circumferences of the Piston [47]. Also apply grease to the inner and outer circumferences of the Piston Pin [48] and Piston Washer [49].
- Mount the Piston Washer [49] on the Piston [47] and then insert the Piston Pin [48].
- Fill the cylinder of the Inner Cover [61] with 20 grams of the specified grease and then insert the Piston [47] into the cylinder of the Inner Cover [61].
- Insert the arm of the Reciprocating Bearing [57] of the Second Shaft [56] ass'y into the Piston Pin [48] so that the arm of the Reciprocating Bearing [57] is sandwiched between the two Piston Washers [49] as shown in the figure below.
- After inserting the arm, mount the Bearing Washer [59] to the rear of the First Gear [58]. Insert the rear end of the Second Shaft [56] into the Ball Bearing 608VV [30] mounted to the Inner Cover [61].
- After inserting the rear end of the Second Shaft [56], allow the inner ring of the Reciprocating Bearing [57] to make one rotation and check that the Piston [47] makes one reciprocation. Pull the Piston [47] to check that it does not come off.
- Pushing the Striker [45] into the Piston [47] compresses the air in the air chamber. The compressed air is released when the O-ring [46] exceeds the breathing channel of the Piston [47]. Push in the Striker [45] until the O-ring [46] exceeds the breathing channel of the Piston [47]. (Listen for the sound of air being released when the O-ring [46] exceeds the breathing channel of the Piston [47].)

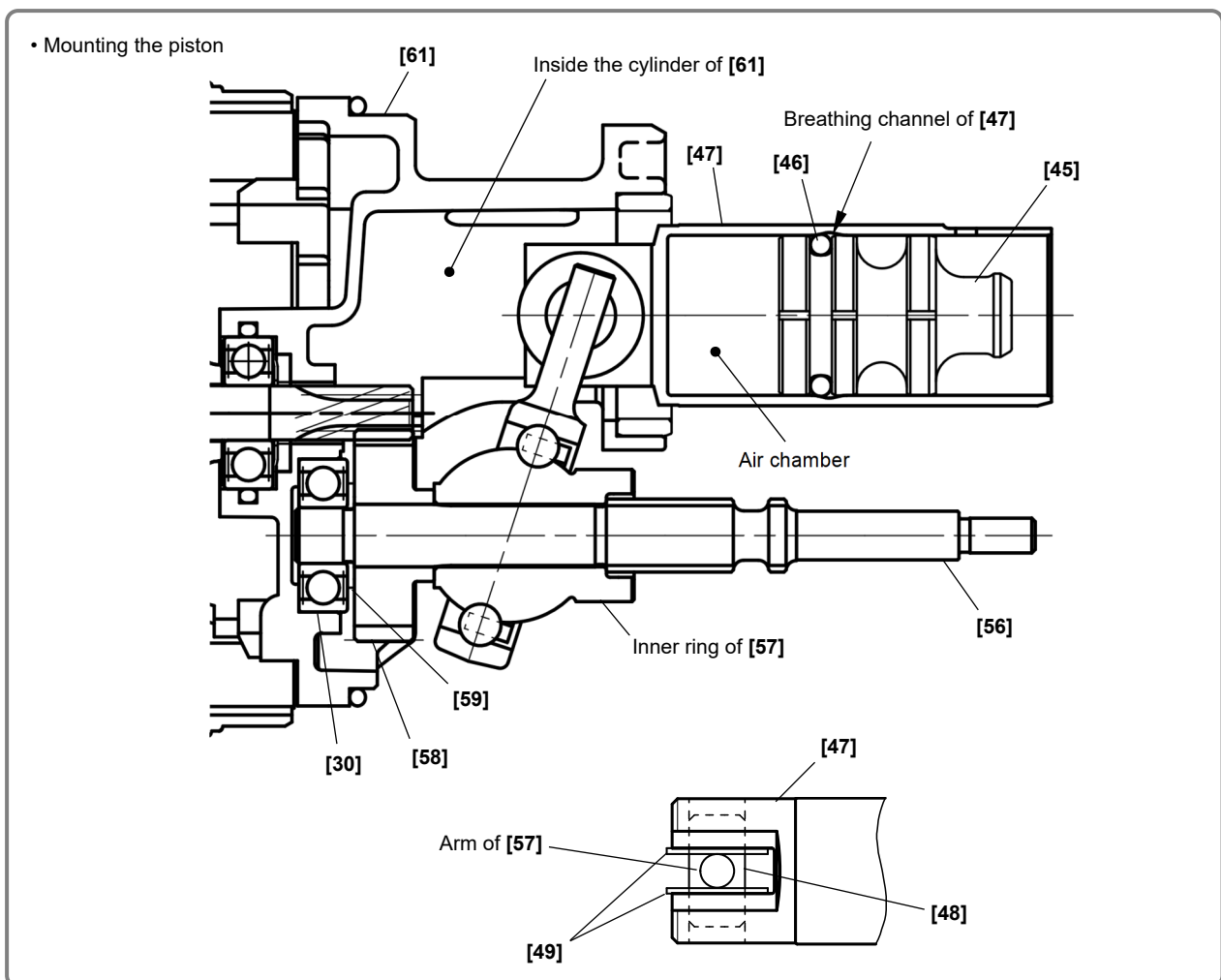

6. Reassembly of the lock plate ass'y

Put Change Plate (C) [55], Washer [54], Clutch [53], Clutch Spring [52], and Second Pinion [51] together and then mount this ass'y to the Lock Plate [50] so that the Second Pinion [51] contacts the Lock Plate [50]. Insert the claw of Change Plate (C) [55] into the hole on the Lock Plate [50].

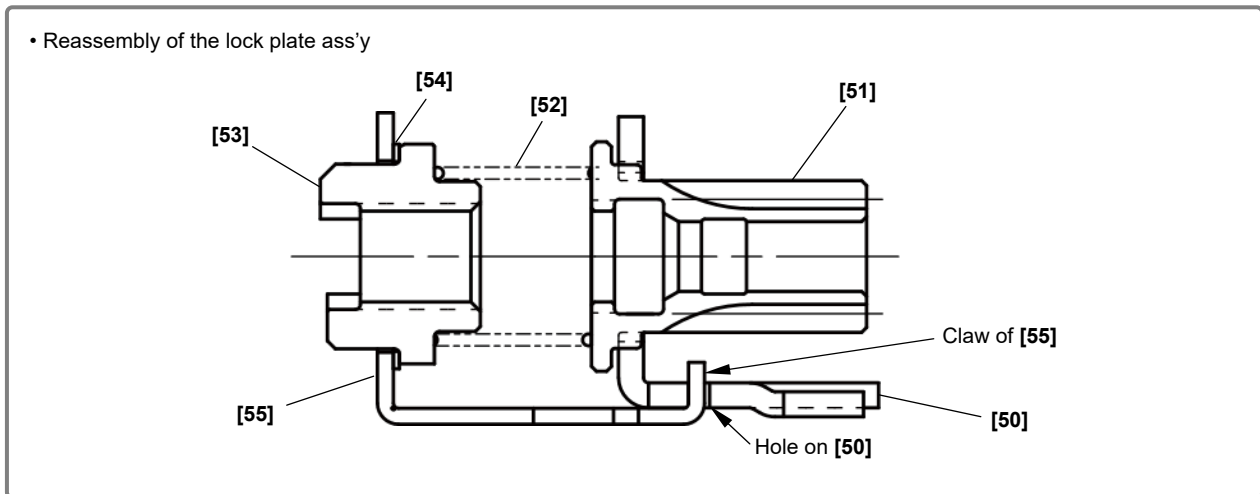

7. Reassembly of the gear cover ass'y

- Mount the O-ring [60] to the Inner Cover [61].
- Mount the Lock Plate [50] ass'y to the Second Shaft [56] inserted in the Inner Cover [61].
- Mount Washer (A) [35] and Cylinder [32] ass'y to the Inner Cover [61] ass'y mounted with the Piston [47].
- Press down the Second Pinion [51] until the spline inside the Second Pinion [51] is aligned with the groove at the rear of the spline of the Second Shaft [56]. Hook the spline inside the Second Pinion [51] on the spline of the Second Shaft [56] and secure the Second Pinion [51] as shown in Fig. 1.
- Engage the claws of the Lock Plate [50] with the claws of the Second Pinion [51] so that the center axis of the Lock Plate [50] is parallel with the center axis of the Second Shaft [56] as shown in Fig. 1. Then, secure the Lock Plate [50] ass'y so that the wing-like surfaces of the Lock Plate [50] and Change Plate (C) [55] are parallel with the plane made by the center axis of the Cylinder [32] and the center axis of the Second Shaft [56] as shown in Fig. 2. At this time, push the claw of Change Plate (C) [55] in as far as it will go to bring the wing-like surface of the Lock Plate [50] into contact with the wing-like surface of Change Plate (C) [55].
- Insert the Ball Bearing 6805 [14] into the Gear Cover Ass'y [28] in which the Oil Seal [13] is press-fitted.
- Fill Shaft Holder (B) [31] with the special grease and insert it into the Ball Bearing 608VV [30] press-fitted in the Gear Cover Ass'y [28]. Insert Spring (E) [29] into the hole beside the bearing chamber inside the Gear Cover Ass'y [28].
- Adjust the position of the Gear Cover Ass'y [28] so that the wing-like portion of Change Plate (C) [55] is inserted into the rail portion of the Gear Cover Ass'y [28]. Put the Gear Cover Ass'y [28] in position until the front end of the Lock Plate [50] can be seen from the insertion hole for the Change Lever [26] (position indicated in Fig. 3).
- Check that the center claw among the three claws at the front end of the Lock Plate [50] is inserted into Spring (E) [29], and then put the Gear Cover Ass'y [28] in position until it contacts housing (B).

NOTE: Be careful not to get the O-ring [60] caught in the Gear Cover Ass'y [28].

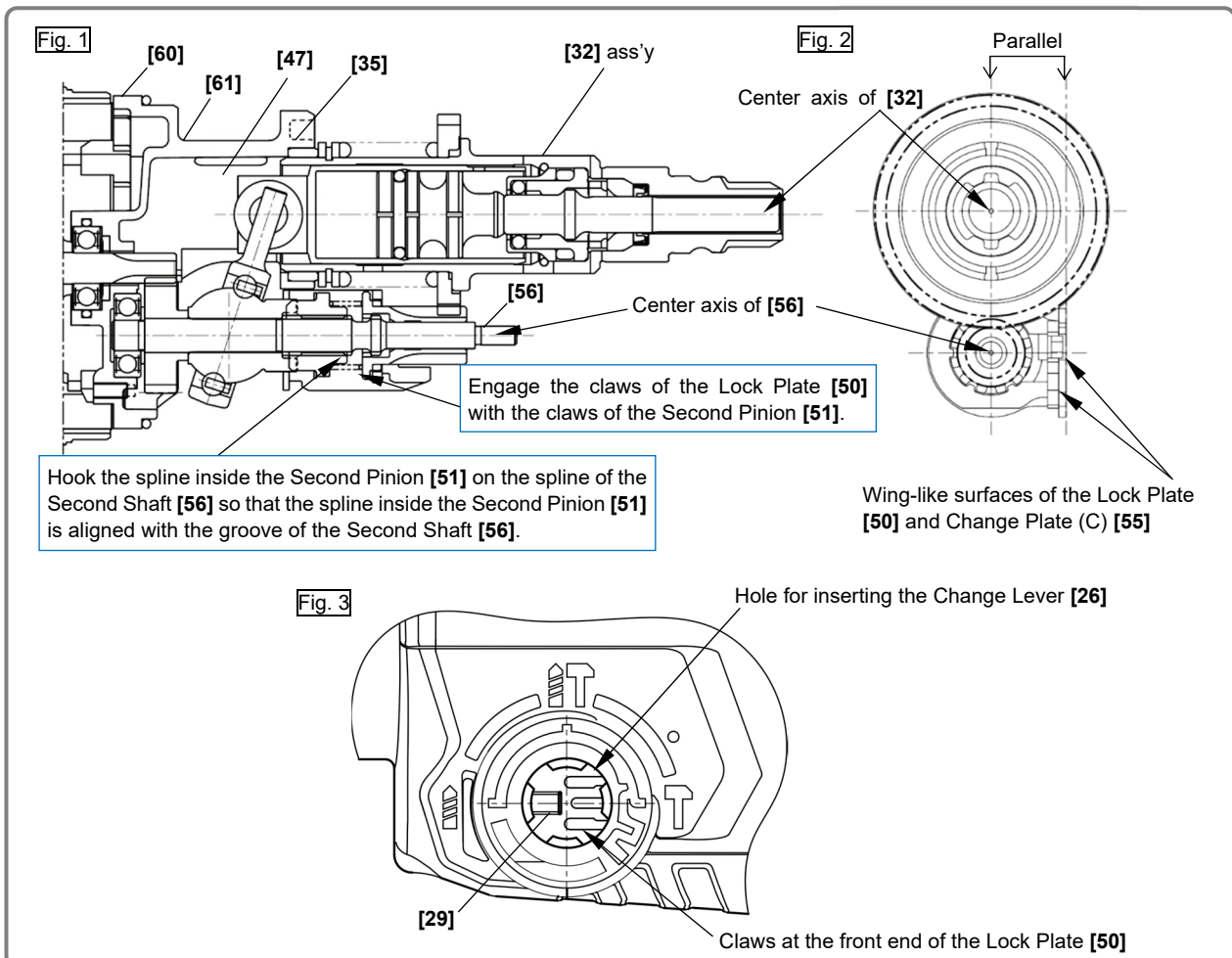

8. Mounting the change lever

- Check that the flange portion of the Second Pinion [51] is positioned as shown in the figure below.
- When the Second Pinion [51] is positioned near the front end, insert a flat-blade screwdriver into the clearance between Change Plate (C) [55] and the flange of the Second Pinion [51], and raise Change Plate (C) [55] to the front and the Second Pinion [51] to the rear. In this state, turn the Second Pinion [51] or Cylinder [32] a little. Then, the spline inside the Second Pinion [51] hooks on the spline of the Second Shaft [56], and the Second Pinion [51] is secured as shown in the figure.
- After adjusting the position of the Second Pinion [51], insert the Change Lever [26] mounted with the Pushing Spring [25], Pushing Button [24], and O-ring [27] into the Gear Cover Ass'y [28] until the Change Lever [26] pin is inserted into the hole of Change Plate (C) [55] with the Change Lever [26] set to "Hammering only" (T mark) position. While pushing the Pushing Button [24] into the hole on the Change Lever [26], turn the Change Lever [26] clockwise until the Pushing Button [24] pin is positioned as shown in the figure below. Then, push the Change Lever [26] in as far as it will go.
- Operate the Change Lever [26] by reversing the disassembly procedure to set to the "Rotation + Hammering" (IT mark) position.

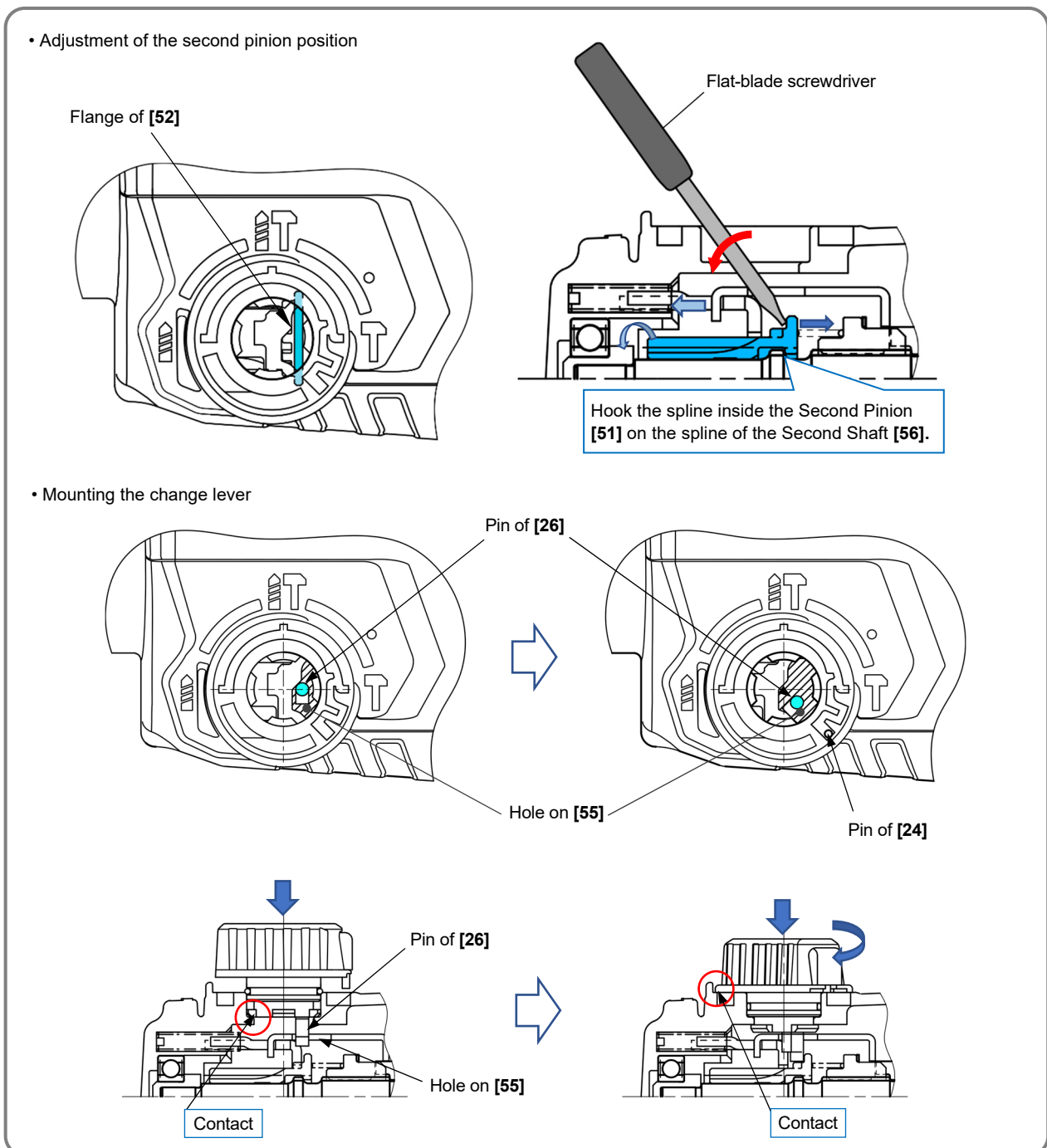

9. Mounting the lock grip





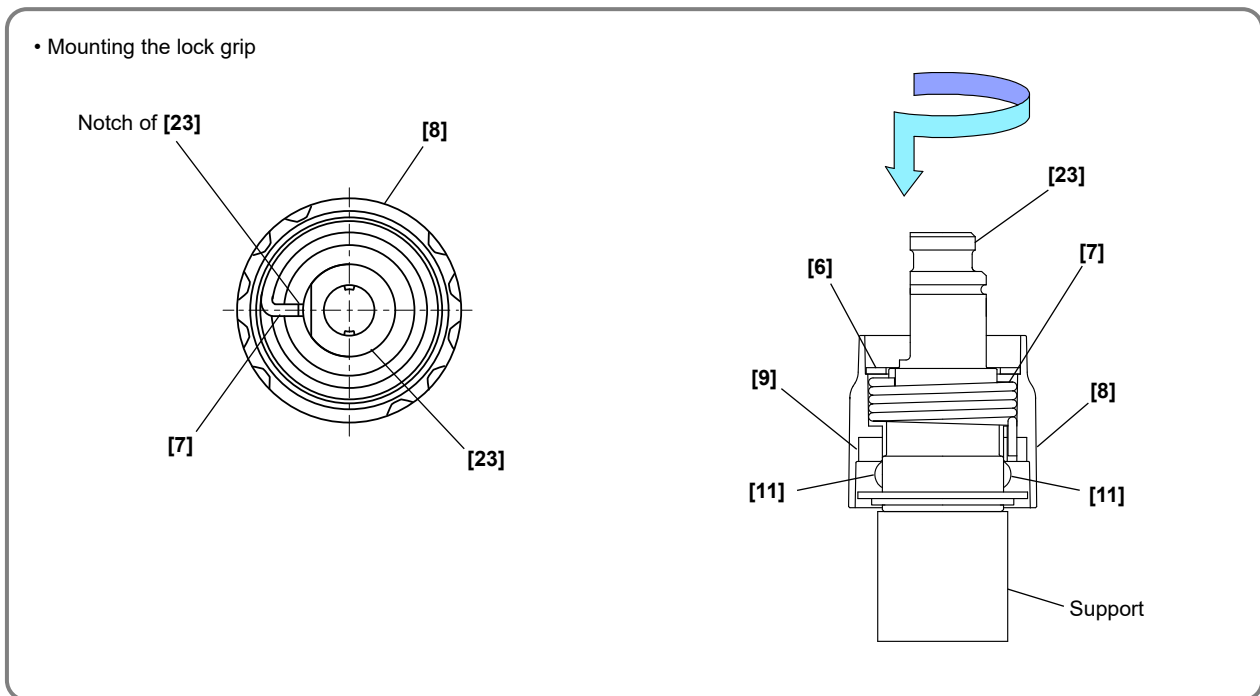

- Mount the Spring [7] and the Lock Ring [9] to the Lock Grip [8]. Mount the Steel Balls D7.0 [11] to Bit Holder (A) [23]. Insert Bit Holder (A) [23] into the Lock Grip [8] aligning the Spring [7] with the notch of Bit Holder (A) [23].
- Place Bit Holder (A) [23] on a suitably-sized support (Cylinder [32] etc.) and mount Washer (B) [6]. Push in the Lock Grip [8] turning in the arrow direction indicated on the Lock Grip [8] as shown in the figure below and fix it with the Retaining Ring for D25 Shaft [5].

NOTE: If it is impossible to mount Washer (B) [6] to the fixing position of the Retaining Ring for D25 Shaft [5], remove Washer (B) [6] and check that the Spring [7] is inserted to the proper position.



10. Operation check

If an improperly assembled product is powered on and its motor runs, components may be damaged. To prevent this, be sure to check the operation of the assembled product by following the procedure below first.

- (1) After reassembly, turn the Change Lever [26] from “Rotation + Hammering” ( mark) to “Rotation only” ( mark) and “Hammering only” ( mark) and check that it is switched normally.
- (2) Set the Change Lever [26] to the “Rotation + Hammering” ( mark) position. Insert the SDS plus shank into Bit Holder (A) Ass'y [15] and let the Cylinder [32] make one rotation. Check that the fan of the Armature [69] rotates.
- (3) Set the Change Lever [26] to the “Rotation only” ( mark) position. Check that the fan rotates in this state.
- (4) Set the Change Lever [26] to the “Hammering only” ( mark) position. Check that the Cylinder [32] does not rotate in this state.

Lubrication points and type of lubricant

Apply the specified grease (rotary hammer grease) to the following portions.

- Periphery of the Second Hammer [39] (Fig. 1), O-ring (C) [42], and Damper (A) [41]
- Oil Seal (A) [37] lip in the Cylinder [32]
- Clutch claws of the Second Gear [33] and Cylinder [32] (Fig. 2)
- Inner circumference of the Cylinder [32] (sliding portion of the Piston [47]) (Fig. 3)
- Bore surface and arm of the Reciprocating Bearing [57] (Fig. 4)
- Reciprocating Bearing [57] rotating shaft, Second Pinion [51] rotating shaft, and spline (Fig. 5)
- Clutch [53], Washer [54], and Change Plate (C) [55] contact portion (Fig. 6)
- Tooth plane of the First Gear [58] and pinion tooth plane of the Armature [69]
- Metal inner circumference of the Inner Cover [61] (Fig. 10)
- Inner and outer surfaces of the Piston [47], inner and outer surfaces of the Piston Pin [48], and Piston Washer [49] (Fig. 7)
- Periphery of the Striker [45] and O-ring [46] for the Striker [45] (Fig. 8)
- Oil Seal [13] lip in the Gear Cover Ass'y [28], ball portion of the Ball Bearing 6805 [14] (Fig. 11), and Spring (E) [29]
- Washer (A) [35]
- Inner circumference of the 20 mm dia. hole of the Gear Cover Ass'y [28] and the O-ring [27] for the Change Lever [26]
- Steel Ball D7.0 [11]
- Contact portion of the Lock Ring [9] and Lock Grip [8]

Fill the following portions with the specified grease (rotary hammer grease).

- Ball portion of the Reciprocating Bearing [57] (Fig. 4)..... 3 g
 - Hollow on abutted surface for the Ball Bearing 608VV [30] of the Gear Cover Ass'y [28] (Fig. 11)··· 0.3 g
 - Inner circumference of Shaft Holder (B) [31] (Fig. 9)
 - Inside of the Gear Cover Ass'y [28] (Fig. 12) 40 g
- NOTE: Be careful not to let grease run into the Cylinder [32].**
- Inside the cylinder of the Inner Cover [61] (Fig. 10)..... 20 g

Apply Nippeco SEP-3A grease (Code No. 930035 (100 g) or 930038 (2.5 kg)) to the following portion.

- Spline at the tip of the Cylinder [32]

- Specified grease (rotary hammer grease)



Net weight	Code No.
500 g	335781
60 g	335782

CAUTION: The viscosity and consistency of this specified grease are optimized for the rotary hammer Models DH 24PMH, DH 26PMC, and DH 26PMX in order to prolong the service life. Therefore, applying other grease to these models may significantly shorten the service life.

Apply or fill with the specified grease unless otherwise specified.

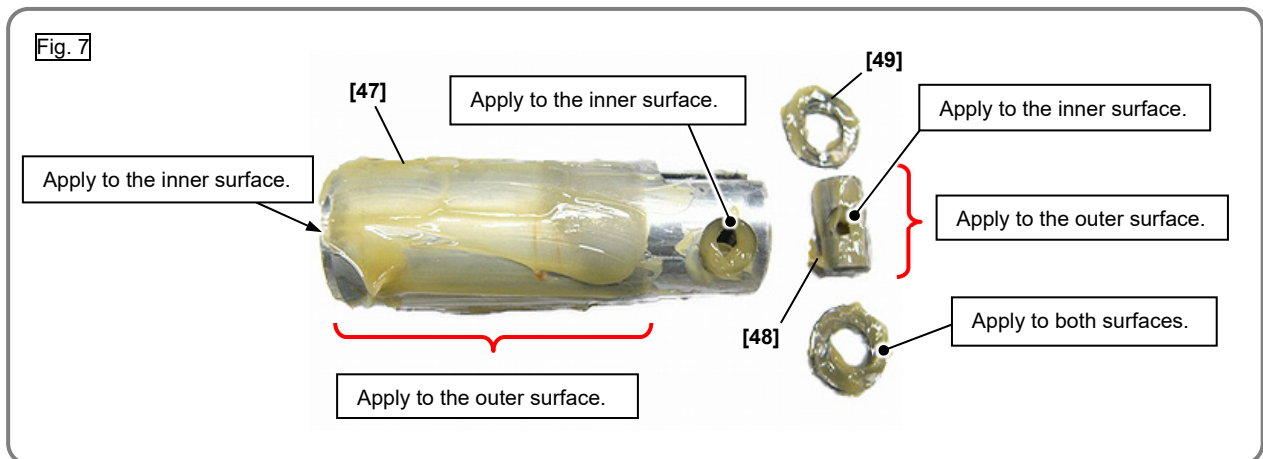
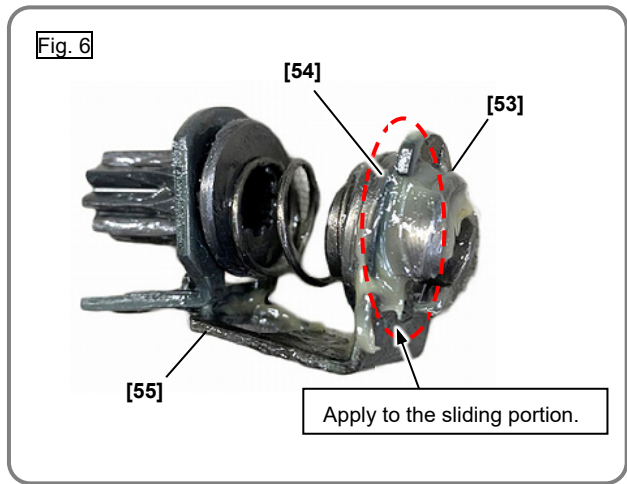
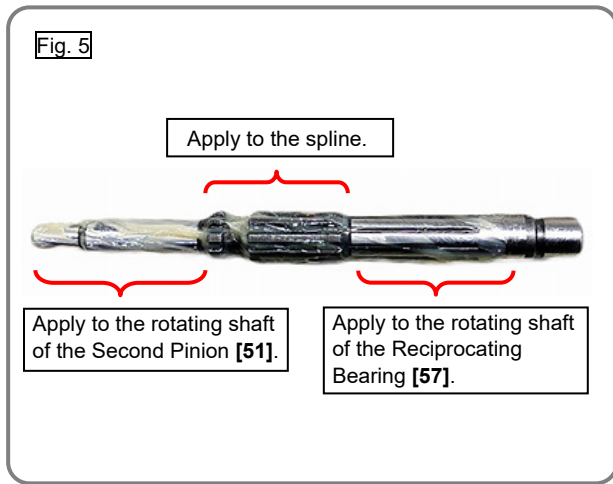
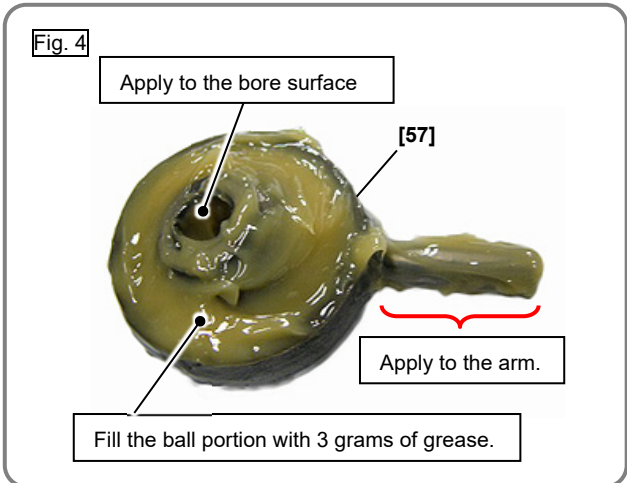
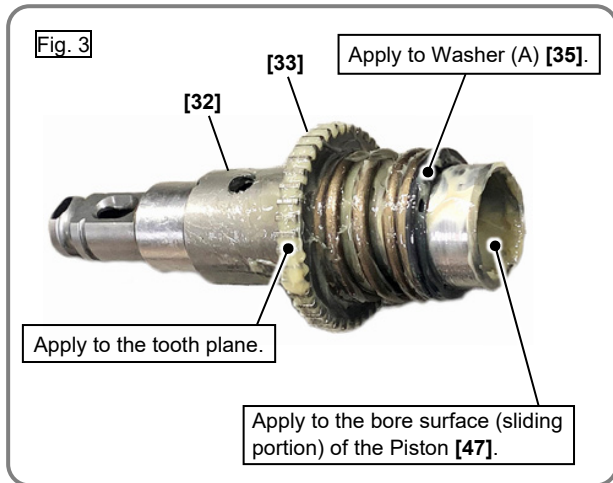
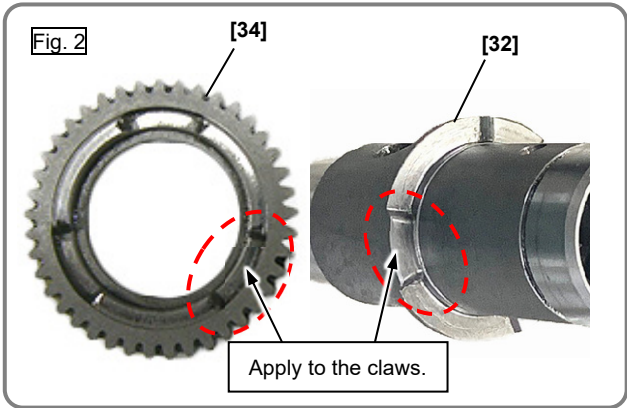
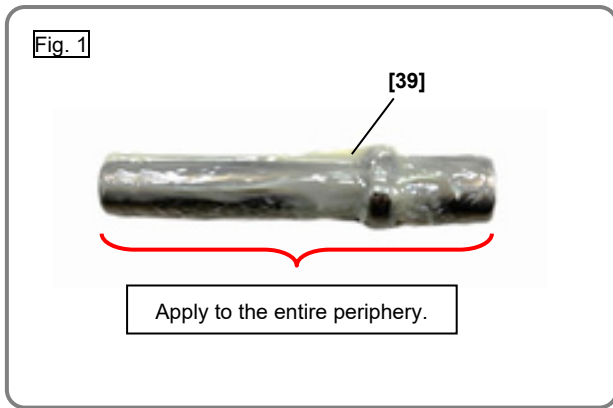

Fig. 8

Apply to the entire periphery of the O-ring [46].



Apply to the outer surface.

Fig. 9

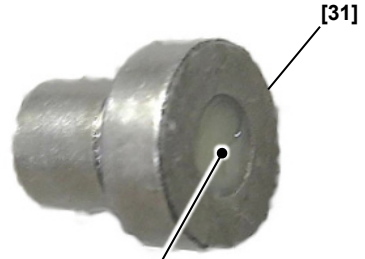

Fill the inner diameter portion.

Fig. 10

Apply to the inner surface of metal.

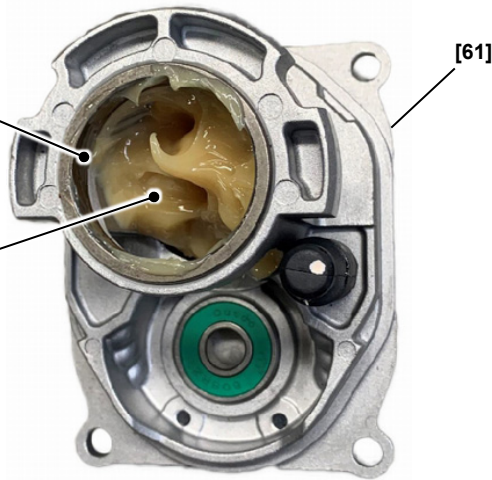

Fill inside of the cylinder with 20 grams of grease.

Fig. 11

Apply to the ball portion of the Ball Bearing 6805 [14].

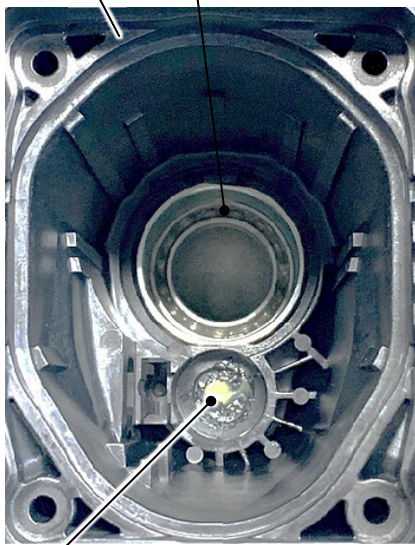

Fill the hollow on the abutted surface for Ball Bearing 608VV [30] with 0.3 gram of grease.

Fig. 12

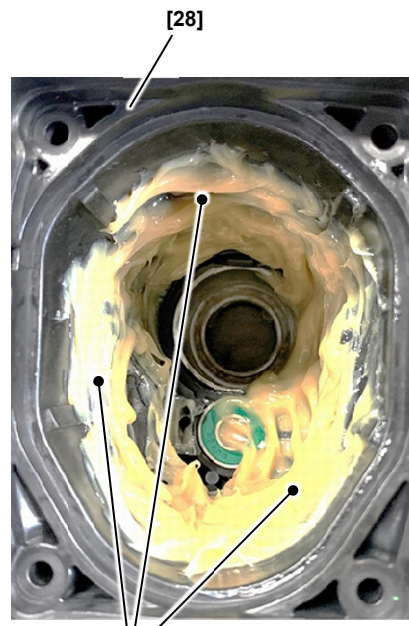

Fill inside of the Gear Cover Ass'y [28] with 40 grams of grease.

Tightening torque

Item No.	Part name	Tightening torque	
		N•m	kgf•cm
[2]	Flat Hd. Screw (A) (Left Hand) M6 x 25	4.9±0.5	50±5
[3]	Drill Chuck 13VLRU-N (W/O Chuck Wrench)	34.3±4.9	350±50
[70]	Hex. Hd. Tapping Screw D4 x 45	1.96±0.5	20±5
(81){81}<79>	Tapping Screw (W/Flange) D5 x 35	2.94±0.5	30±5
(85){85}<83>	Tapping Screw (W/Flange) D4 x 16	1.96±0.5	20±5
(87){87}<85>	Tapping Screw (W/Flange) D4 x 20 (Black)	1.96±0.5	20±5

Insulation test

Measure the insulation resistance and conduct a dielectric strength test after reassembly.

- Insulation resistance: 7 MΩ or higher (as measured with a 500 VDC megohm tester)
- Dielectric strength: 2,500 VAC per minute, with no abnormalities

No-load current value

After no-load operation for 30 minutes, the no-load current value at a frequency of 50/60 Hz must be as follows.

DH 24PMH

Voltage	110 V	220 V	230 V	240 V
Current max.	7.0 A	3.5 A	3.3 A	3.2 A

DH 26PMC and DH 26PMX

Voltage	110 V	220 V	230 V	240 V
Current max.	4.2 A	1.9 A	2.0 A	1.9 A

Connecting diagram

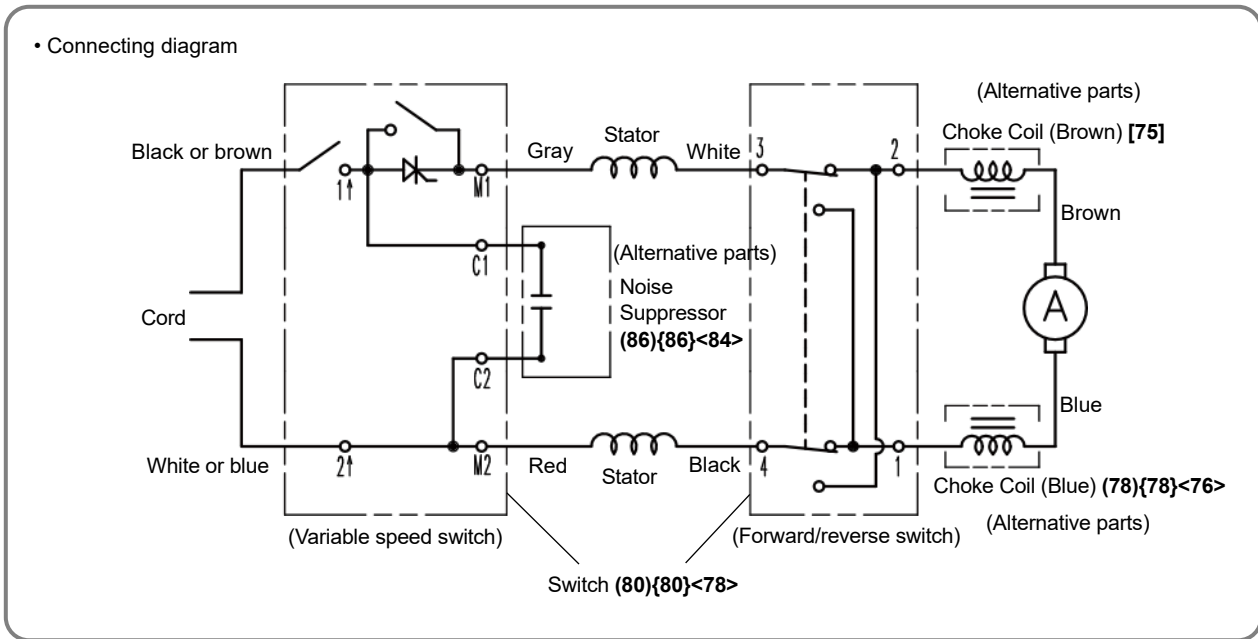

Switch-related wiring

(1) Wiring of the forward/reverse changeover switch

- Insert the Choke Coil (Blue) (78){78}<76> or the Internal Wire (Blue) (77){77} into the terminal (1) and the Choke Coil (Brown) [75] or the Internal Wire (Brown) (76){76} into the terminal (2) marked on the Switch (80){80}<78> as shown in the figure below. Then, insert the white internal wire coming from the Stator [71] into the terminal (3) and the black internal wire coming from the Stator [71] into the terminal (4) marked on the Switch (80){80}<78>.
- After inserting the internal wires, pull the internal wires lightly to check that they do not come off.
- When removing the internal wires, insert the tip of a small flat-blade screwdriver or a needle into the window portion provided on the side of each terminal and pull out the internal wire.

(2) Wiring of the variable speed switch

- Insert the black or brown Cord (82){82}<80> into the terminal (1↑) and the white or blue Cord (82){82}<80> into the terminal (2↑) marked on the Switch (80){80}<78> as shown in the figure below. Tighten each terminal screw with tightening torque of 0.5 ± 0.1 N•m (5 ± 1 kg•cm).
- Insert the gray internal wire coming from the Stator [71] into the terminal (M1) and the red internal wire coming from the Stator [71] into the terminal (M2). Insert the internal wires coming from the Noise Suppressor (86){86}<84> into the terminals (C1) and (C2).
- After inserting the cords and internal wires, pull them lightly to check that they do not come off.
- When removing the internal wires, insert the tip of a small flat-blade screwdriver or a needle into the window portion provided on the side of each terminal and pull out the internal wire.

• Switch-related wiring

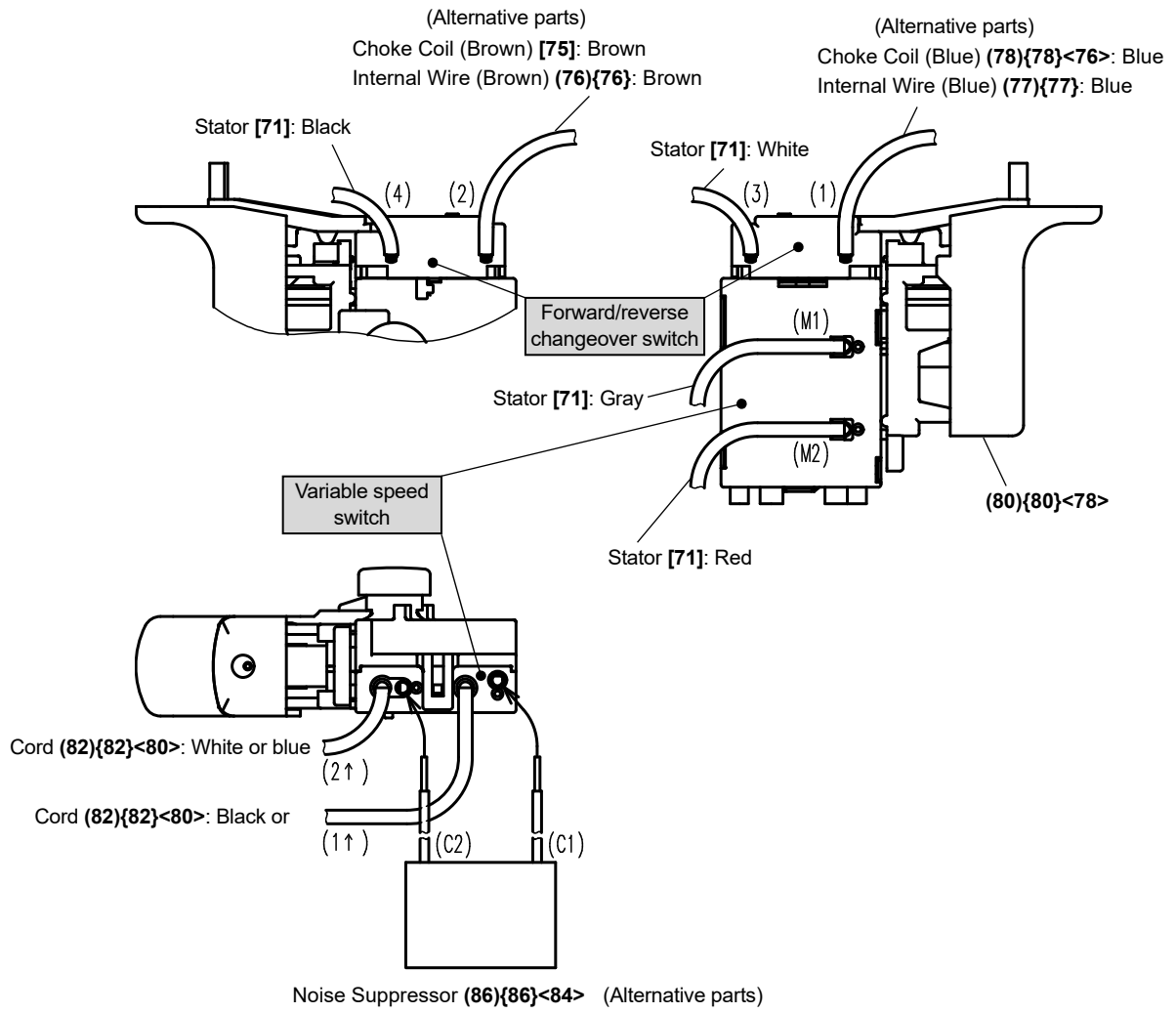

Wiring diagram

• Wiring diagram of the power supply unit

: Be careful not to get the internal wires caught.

(Alternative parts)
Choke Coil (Blue) (78){78}<76>

Be careful not to overlap the gray and red internal wires under the switch. Be careful not to put the internal wires on the rib.

5 to 10 mm

(When the choke coil is provided)

Insert the choke coil diagonally in the direction of the arrow so that the tip of the tube is positioned to the right innermost part and the internal wire to the left front.

Be careful not to overlap the blue and white internal wires over the switch.

Avoid contact of the internal wire with the forward/reverse change lever.

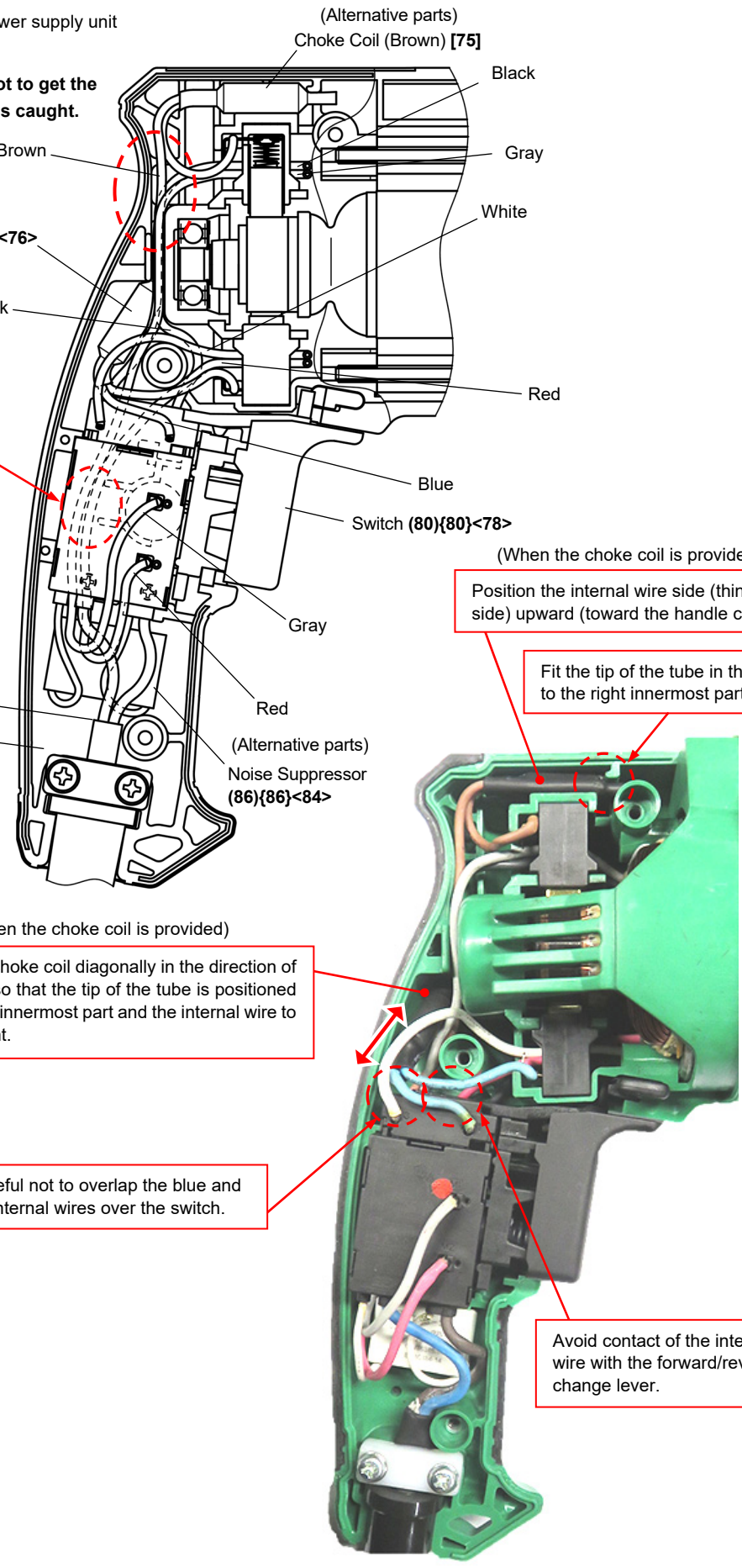

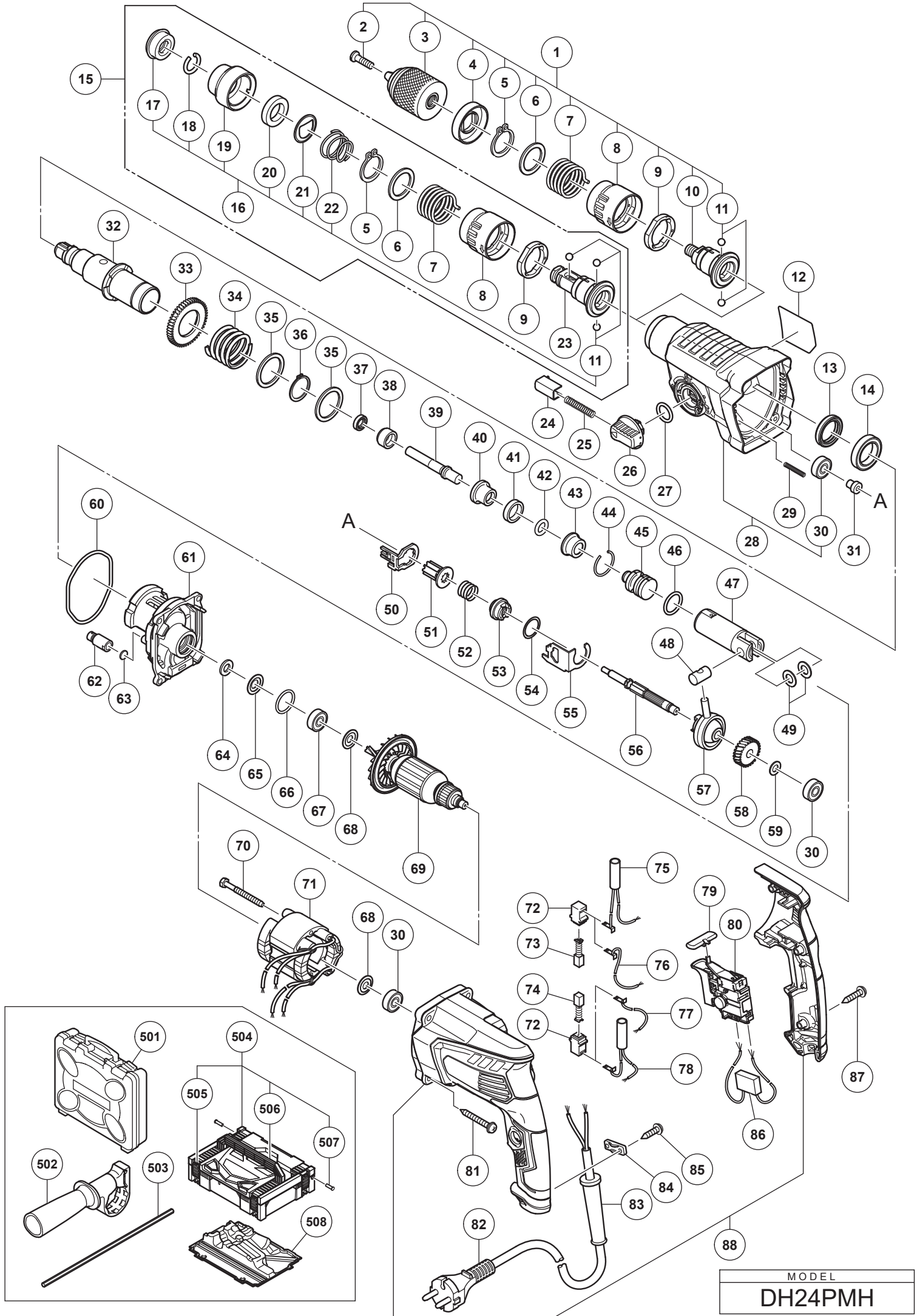

MODEL
DH24PMH

ITEM NO.	CODE NO.	DESCRIPTION	NO. USED	REMARKS
1	377959	CHUCK HOLDER ASS'Y	1	INCLUD. 2-11
2	995344	FLAT HD. SCREW (A) (LEFT HAND) M6 X 25	1	
3	335961	DRILL CHUCK 13VLRU-N (W/O CHUCK WRENCH)	1	
4	326527	STOPPER	1	
5	965469	RETAINING RING FOR D25 SHAFT	2	
6	326520	WASHER (B)	2	
7	326519	SPRING	2	
8	375013	LOCK GRIP	2	
9	326801	LOCK RING	2	
10	375011	CHUCK HOLDER (A)	1	
11	335300	STEEL BALL D7.0 (10 PCS.)	5	
12		NAME PLATE	1	
13	335259	OIL SEAL	1	
14	6805BB	BALL BEARING 6805	1	
15	375010	BIT HOLDER (A) ASS'Y	1	INCLUD. 5-9, 16, 23
16	375363	GRIP SET	1	INCLUD. 11, 17-22
17	306345	FRONT CAP	1	
18	306340	STOPPER RING	1	
19	374436	GRIP	1	
20	374437	BALL HOLDER	1	
21	374435	HOLDER PLATE	1	
22	322812	HOLDER SPRING	1	
23	375009	BIT HOLDER (A)	1	
24	322789	PUSHING BUTTON	1	
25	317223	PUSHING SPRING	1	
26	334011	CHANGE LEVER	1	
27	878885	O-RING (S-18)	1	
28	377961	GEAR COVER ASS'Y	1	INCLUD. 30
29	335800	SPRING (E)	1	
30	608VVM	BALL BEARING 608VVC2PS2L	3	
31	374422	SHAFT HOLDER (B)	1	
32	375007	CYLINDER	1	
33	335265	SECOND GEAR	1	
34	374430	SPRING (B)	1	
35	301679	WASHER (A)	2	
36	948310	RETAINING RING FOR D30 SHAFT	1	
37	335262	OIL SEAL (A)	1	
38	375014	HAMMER HOLDER (D)	1	
39	375008	SECOND HAMMER	1	
40	374429	HAMMER HOLDER (A)	1	
41	322805	DAMPER (A)	1	
42	322808	O-RING (C)	1	
43	324524	DAMPER HOLDER	1	
44	322807	STOPPER RING	1	
45	374443	STRIKER	1	
46	372816	O-RING	1	
47	372817	PISTON	1	
48	335793	PISTON PIN	1	
49	335794	PISTON WASHER	2	
50	374434	LOCK PLATE	1	
51	374440	SECOND PINION	1	
52	323182	CLUTCH SPRING	1	
53	375022	CLUTCH	1	
54	331315	WASHER	1	
55	374439	CHANGE PLATE (C)	1	
56	374438	SECOND SHAFT	1	
57	335249	RECIPROCATING BEARING	1	
58	374441	FIRST GEAR	1	
59	374442	BEARING WASHER	1	
60	335245	O-RING D72.2	1	
61	374433	INNER COVER	1	
62	334008	AIR CAP	1	
63	324543	FELT PACKING (A)	1	
64	322816	FELT PACKING	1	
65	322818	PACKING WASHER	1	
66	876796	O-RING (P-22)	1	
67	608DDM	BALL BEARING 608DD	1	
68	982631	WASHER (A)	2	
*69	361110C	ARMATURE (C) 110 V	1	
*69	361110E	ARMATURE (C) 220 V-230 V	1	
*69	361110F	ARMATURE (C) 240 V	1	
70	981824	HEX. HD. TAPPING SCREW D4 X 45	2	

ITEM NO.	CODE NO.	DESCRIPTION	NO. USED	REMARKS
*71	341031H	STATOR (C) 110 V	1	
*71	341031K	STATOR (C) 220 V-230 V	1	
*71	341031L	STATOR (C) 240 V	1	
72	955203	BRUSH HOLDER	2	
73	999041	CARBON BRUSH (1 PAIR)	1	
74	999072	CARBON BRUSH (AUTO STOP TYPE) (1 PAIR)	1	
*75	374615	CHOKE COIL (BROWN)	1	FOR EUROPE, SAF, TUR
*76	374613	INTERNAL WIRE (BROWN)	1	FOR SIN, MAL, HKG, THA, UAE
*77	374612	INTERNAL WIRE (BLUE)	1	FOR SIN, MAL, HKG, THA, UAE
*78	374614	CHOKE COIL (BLUE)	1	FOR EUROPE, SAF, TUR
79	322853	PUSHING BUTTON	1	
*80	374611	SWITCH 100 V-127 V	1	
*80	374610	SWITCH 220 V-240 V	1	
81	301654	TAPPING SCREW (W/FLANGE) D5 X 35	4	
*82	500423Z	CORD	1	(CORD ARMOR D8.8)
*82	500247Z	CORD	1	(CORD ARMOR D8.8) FOR EUROPE, SAF, TUR
*82	930051	CORD	1	(CORD ARMOR D10.1) FOR SIN (110 V), HKG (110 V)
*82	500468Z	CORD	1	(CORD ARMOR D8.8) FOR THA
*83	953327	CORD ARMOR D8.8	1	
*83	938051	CORD ARMOR D10.1	1	
84	937631	CORD CLIP	1	
85	984750	TAPPING SCREW (W/FLANGE) D4 X 16	2	
*86	930039	NOISE SUPPRESSOR	1	FOR EUROPE, SAF, TUR
87	301653	TAPPING SCREW (W/FLANGE) D4 X 20 (BLACK)	3	
88	376298	HOUSING SET	1	
STANDARD ACCESSORIES				
*501	377962	CASE	1	
502	324548	SIDE HANDLE	1	
503	303709	DEPTH GAUGE	1	
*504	337739	CASE ASS'Y (STACKABLE 1)	1	INCLUD. 505-507
*505	336472	LATCH	4	
*506	336473	HANDLE	1	
*507	336474	HINGE	2	
*508	377960	INNER TRAY	1	
OPTIONAL ACCESSORIES				
601	306885	DUST COLLECTOR (B) ASS'Y	1	INCLUD. 602, 610
602	986802	DUST COLLECTOR ASS'Y	1	INCLUD. 603-609
603	986803	DUST COVER	1	
604	986804	SEAL COVER	1	
605	948310	RETAINING RING FOR D30 SHAFT	1	
606	958063	WASHER	1	
607	959150	STEEL BALL D6.35 (10 PCS.)	19	
608	986805	OUTER RACE	1	
609	986806	SOCKET	1	
610	306910	SOCKET ADAPTER (B)	1	
611	971787	DUST CUP	1	
612	931844	STOPPER	1	
613	321814	DRILL CHUCK 13VLRB-D	1	INCLUD. 614
614	331966	FLAT HD. SCREW (LEFT HAND) M6 X 20	1	
615	321813	DRILL CHUCK 13VLD-D	1	
616	971511Z	+ DRIVER BIT (A) NO. 2 25L	1	
617	971512Z	+ DRIVER BIT (A) NO. 3 25L	1	
618	971794	ANCHOR SETTING ADAPTER A W1/4" (MANUAL)	1	
619	971795	ANCHOR SETTING ADAPTER A W5/16" (MANUAL)	1	
620	971796	ANCHOR SETTING ADAPTER A W3/8" (MANUAL)	1	
621	971797	ANCHOR SETTING ADAPTER A W1/2" (MANUAL)	1	
622	971798	ANCHOR SETTING ADAPTER A W5/8" (MANUAL)	1	
623	971799	ANCHOR SETTING ADAPTER B W1/4" (MANUAL)	1	
624	971800	ANCHOR SETTING ADAPTER B W5/16" (MANUAL)	1	
625	971801	ANCHOR SETTING ADAPTER B W3/8" (MANUAL)	1	
626	971802	ANCHOR SETTING ADAPTER B W1/2" (MANUAL)	1	
627	971803	ANCHOR SETTING ADAPTER B W5/8" (MANUAL)	1	
628	320859	SYRINGE (BLOW-OUT BULB TYPE)	1	
629	944477	COTTER	1	
630	982684	CENTER PIN (A) 109L FOR CORE BIT D32-38	1	
631	982685	CENTER PIN (B) 104L FOR CORE BIT D45-90	1	
632	335781	GREASE FOR ROTARY HAMMER (500 G)	1	
633	335782	GREASE FOR ROTARY HAMMER (60 G)	1	

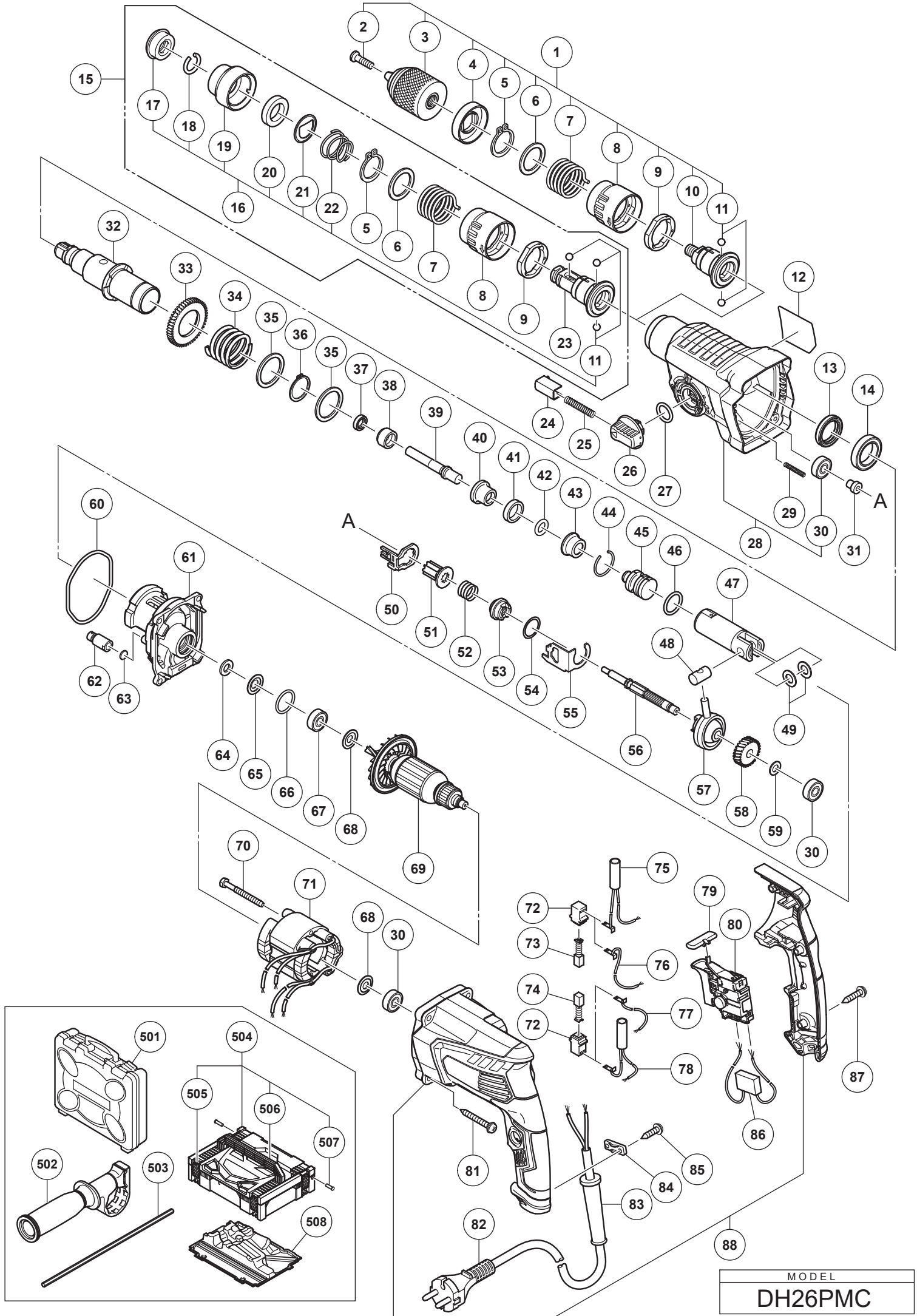

MODEL
DH26PMC

ITEM NO.	CODE NO.	DESCRIPTION	NO. USED	REMARKS
1	377959	CHUCK HOLDER ASS'Y	1	INCLUD. 2-11
2	995344	FLAT HD. SCREW (A) (LEFT HAND) M6 X 25	1	
3	335961	DRILL CHUCK 13VLRU-N (W/O CHUCK WRENCH)	1	
4	326527	STOPPER	1	
5	965469	RETAINING RING FOR D25 SHAFT	2	
6	326520	WASHER (B)	2	
7	326519	SPRING	2	
8	375013	LOCK GRIP	2	
9	326801	LOCK RING	2	
10	375011	CHUCK HOLDER (A)	1	
11	335300	STEEL BALL D7.0 (10 PCS.)	5	
12		NAME PLATE	1	
13	335259	OIL SEAL	1	
14	6805BB	BALL BEARING 6805	1	
15	375010	BIT HOLDER (A) ASS'Y	1	INCLUD. 5-9, 16, 23
16	375363	GRIP SET	1	INCLUD. 11, 17-22
17	306345	FRONT CAP	1	
18	306340	STOPPER RING	1	
19	374436	GRIP	1	
20	374437	BALL HOLDER	1	
21	374435	HOLDER PLATE	1	
22	322812	HOLDER SPRING	1	
23	375009	BIT HOLDER (A)	1	
24	322789	PUSHING BUTTON	1	
25	317223	PUSHING SPRING	1	
26	334011	CHANGE LEVER	1	
27	878885	O-RING (S-18)	1	
28	377961	GEAR COVER ASS'Y	1	INCLUD. 30
29	335800	SPRING (E)	1	
30	608VVM	BALL BEARING 608VVC2PS2L	3	
31	374422	SHAFT HOLDER (B)	1	
32	375007	CYLINDER	1	
33	335265	SECOND GEAR	1	
34	374430	SPRING (B)	1	
35	301679	WASHER (A)	2	
36	948310	RETAINING RING FOR D30 SHAFT	1	
37	335262	OIL SEAL (A)	1	
38	375014	HAMMER HOLDER (D)	1	
39	375008	SECOND HAMMER	1	
40	374429	HAMMER HOLDER (A)	1	
41	322805	DAMPER (A)	1	
42	322808	O-RING (C)	1	
43	324524	DAMPER HOLDER	1	
44	322807	STOPPER RING	1	
45	374443	STRIKER	1	
46	372816	O-RING	1	
47	372817	PISTON	1	
48	335793	PISTON PIN	1	
49	335794	PISTON WASHER	2	
50	374434	LOCK PLATE	1	
51	374440	SECOND PINION	1	
52	323182	CLUTCH SPRING	1	
53	375022	CLUTCH	1	
54	331315	WASHER	1	
55	374439	CHANGE PLATE (C)	1	
56	374438	SECOND SHAFT	1	
57	335249	RECIPROCATING BEARING	1	
58	374441	FIRST GEAR	1	
59	374442	BEARING WASHER	1	
60	335245	O-RING D72.2	1	
61	374433	INNER COVER	1	
62	334008	AIR CAP	1	
63	324543	FELT PACKING (A)	1	
64	322816	FELT PACKING	1	
65	322818	PACKING WASHER	1	
66	876796	O-RING (P-22)	1	
67	608DDM	BALL BEARING 608DD	1	
68	982631	WASHER (A)	2	
*69	361106C	ARMATURE (A) 110 V	1	
*69	361106E	ARMATURE (A) 220 V-230 V	1	
*69	361106F	ARMATURE (A) 240 V	1	
70	981824	HEX. HD. TAPPING SCREW D4 X 45	2	

ITEM NO.	CODE NO.	DESCRIPTION	NO. USED	REMARKS
*71	341028H	STATOR (A) 110 V	1	
*71	341028K	STATOR (A) 220 V-230 V	1	
*71	341028L	STATOR (A) 240 V	1	
72	955203	BRUSH HOLDER	2	
73	999041	CARBON BRUSH (1 PAIR)	1	
74	999072	CARBON BRUSH (AUTO STOP TYPE) (1 PAIR)	1	
*75	374615	CHOKE COIL (BROWN)	1	FOR EUROPE, CHN, SAF, TUR
*76	374613	INTERNAL WIRE (BROWN)	1	FOR SIN, MAL, HKG, THA, UAE
*77	374612	INTERNAL WIRE (BLUE)	1	FOR SIN, MAL, HKG, THA, UAE
*78	374614	CHOKE COIL (BLUE)	1	FOR EUROPE, CHN, SAF, TUR
79	322853	PUSHING BUTTON	1	
*80	374611	SWITCH 100 V-127 V	1	
*80	374610	SWITCH 220 V-240 V	1	
81	301654	TAPPING SCREW (W/FLANGE) D5 X 35	4	
*82	500239Z	CORD	1	(CORD ARMOR D10.1)
*82	500424Z	CORD	1	(CORD ARMOR D8.8) FOR SIN (230 V), UAE (230 V), MAL (240 V)
*82	500390Z	CORD	1	(CORD ARMOR D8.8) FOR EUROPE, SAF, TUR
*82	500440Z	CORD	1	(CORD ARMOR D8.8) FOR HKG (220 V)
*82	500496Z	CORD	1	(CORD ARMOR D8.8) FOR CHN
*83	953327	CORD ARMOR D8.8	1	
*83	938051	CORD ARMOR D10.1	1	
84	937631	CORD CLIP	1	
85	984750	TAPPING SCREW (W/FLANGE) D4 X 16	2	
*86	930039	NOISE SUPPRESSOR	1	FOR EUROPE, CHN, SAF, TUR
87	301653	TAPPING SCREW (W/FLANGE) D4 X 20 (BLACK)	3	
88	376296	HOUSING SET	1	
STANDARD ACCESSORIES				
*501	377962	CASE	1	
502	374447	SIDE HANDLE	1	
503	303709	DEPTH GAUGE	1	
*504	337739	CASE ASS'Y (STACKABLE 1)	1	INCLUD. 505-507
*505	336472	LATCH	4	
*506	336473	HANDLE	1	
*507	336474	HINGE	2	
*508	377960	INNER TRAY	1	
OPTIONAL ACCESSORIES				
601	306885	DUST COLLECTOR (B) ASS'Y	1	INCLUD. 602, 610
602	986802	DUST COLLECTOR ASS'Y	1	INCLUD. 603-609
603	986803	DUST COVER	1	
604	986804	SEAL COVER	1	
605	948310	RETAINING RING FOR D30 SHAFT	1	
606	958063	WASHER	1	
607	959150	STEEL BALL D6.35 (10 PCS.)	19	
608	986805	OUTER RACE	1	
609	986806	SOCKET	1	
610	306910	SOCKET ADAPTER (B)	1	
611	971787	DUST CUP	1	
612	931844	STOPPER	1	
613	321814	DRILL CHUCK 13VLRB-D	1	INCLUD. 614
614	331966	FLAT HD. SCREW (LEFT HAND) M6 X 20	1	
615	321813	DRILL CHUCK 13VLD-D	1	
616	971511Z	+ DRIVER BIT (A) NO. 2 25L	1	
617	971512Z	+ DRIVER BIT (A) NO. 3 25L	1	
618	971794	ANCHOR SETTING ADAPTER A W1/4" (MANUAL)	1	
619	971795	ANCHOR SETTING ADAPTER A W5/16" (MANUAL)	1	
620	971796	ANCHOR SETTING ADAPTER A W3/8" (MANUAL)	1	
621	971797	ANCHOR SETTING ADAPTER A W1/2" (MANUAL)	1	
622	971798	ANCHOR SETTING ADAPTER A W5/8" (MANUAL)	1	
623	971799	ANCHOR SETTING ADAPTER B W1/4" (MANUAL)	1	
624	971800	ANCHOR SETTING ADAPTER B W5/16" (MANUAL)	1	
625	971801	ANCHOR SETTING ADAPTER B W3/8" (MANUAL)	1	
626	971802	ANCHOR SETTING ADAPTER B W1/2" (MANUAL)	1	
627	971803	ANCHOR SETTING ADAPTER B W5/8" (MANUAL)	1	
628	320859	SYRINGE (BLOW-OUT BULB TYPE)	1	
629	944477	COTTER	1	
630	982684	CENTER PIN (A) 109L FOR CORE BIT D32-38	1	
631	982685	CENTER PIN (B) 104L FOR CORE BIT D45-90	1	
632	335781	GREASE FOR ROTARY HAMMER (500 G)	1	
633	335782	GREASE FOR ROTARY HAMMER (60 G)	1	

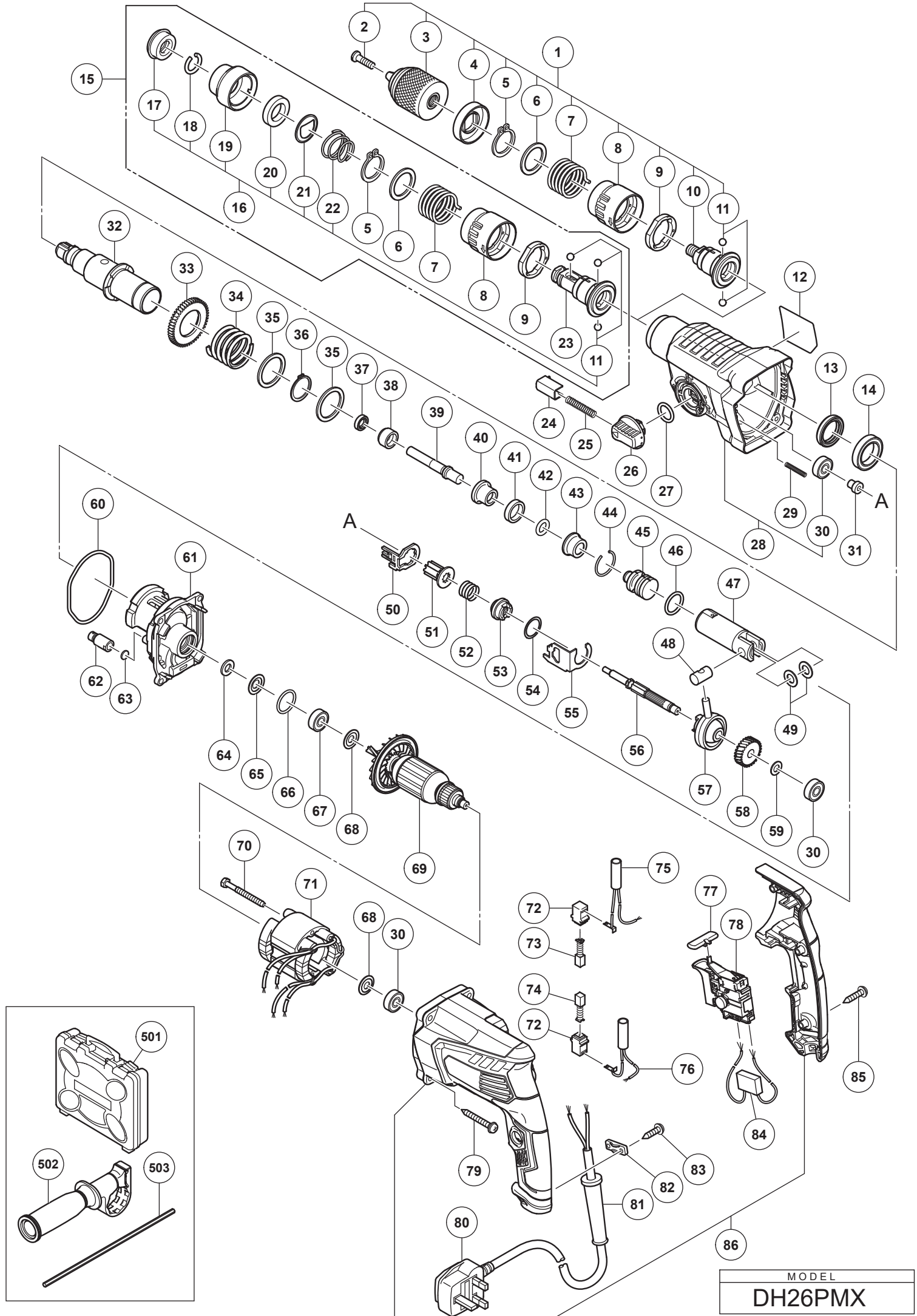

ITEM NO.	CODE NO.	DESCRIPTION	NO. USED	REMARKS
1	377959	CHUCK HOLDER ASS'Y	1	INCLUD. 2-11
2	995344	FLAT HD. SCREW (A) (LEFT HAND) M6 X 25	1	
3	335961	DRILL CHUCK 13VLRU-N (W/O CHUCK WRENCH)	1	
4	326527	STOPPER	1	
5	965469	RETAINING RING FOR D25 SHAFT	2	
6	326520	WASHER (B)	2	
7	326519	SPRING	2	
8	375013	LOCK GRIP	2	
9	326801	LOCK RING	2	
10	375011	CHUCK HOLDER (A)	1	
11	335300	STEEL BALL D7.0 (10 PCS.)	5	
12		NAME PLATE	1	
13	335259	OIL SEAL	1	
14	6805BB	BALL BEARING 6805	1	
15	375010	BIT HOLDER (A) ASS'Y	1	INCLUD. 5-9, 16, 23
16	375363	GRIP SET	1	INCLUD. 11, 17-22
17	306345	FRONT CAP	1	
18	306340	STOPPER RING	1	
19	374436	GRIP	1	
20	374437	BALL HOLDER	1	
21	374435	HOLDER PLATE	1	
22	322812	HOLDER SPRING	1	
23	375009	BIT HOLDER (A)	1	
24	322789	PUSHING BUTTON	1	
25	317223	PUSHING SPRING	1	
26	334011	CHANGE LEVER	1	
27	878885	O-RING (S-18)	1	
28	377961	GEAR COVER ASS'Y	1	INCLUD. 30
29	335800	SPRING (E)	1	
30	608VVM	BALL BEARING 608VVC2PS2L	3	
31	374422	SHAFT HOLDER (B)	1	
32	375007	CYLINDER	1	
33	335265	SECOND GEAR	1	
34	374430	SPRING (B)	1	
35	301679	WASHER (A)	2	
36	948310	RETAINING RING FOR D30 SHAFT	1	
37	335262	OIL SEAL (A)	1	
38	375014	HAMMER HOLDER (D)	1	
39	375008	SECOND HAMMER	1	
40	374429	HAMMER HOLDER (A)	1	
41	322805	DAMPER (A)	1	
42	322808	O-RING (C)	1	
43	324524	DAMPER HOLDER	1	
44	322807	STOPPER RING	1	
45	374443	STRIKER	1	
46	372816	O-RING	1	
47	372817	PISTON	1	
48	335793	PISTON PIN	1	
49	335794	PISTON WASHER	2	
50	374434	LOCK PLATE	1	
51	374440	SECOND PINION	1	
52	323182	CLUTCH SPRING	1	
53	375022	CLUTCH	1	
54	331315	WASHER	1	
55	374439	CHANGE PLATE (C)	1	
56	374438	SECOND SHAFT	1	
57	335249	RECIPROCATING BEARING	1	
58	374441	FIRST GEAR	1	
59	374442	BEARING WASHER	1	
60	335245	O-RING D72.2	1	
61	374433	INNER COVER	1	
62	334008	AIR CAP	1	
63	324543	FELT PACKING (A)	1	
64	322816	FELT PACKING	1	
65	322818	PACKING WASHER	1	
66	876796	O-RING (P-22)	1	
67	608DDM	BALL BEARING 608DD	1	
68	982631	WASHER (A)	2	
*69	361106C	ARMATURE (A) 110 V	1	
*69	361106E	ARMATURE (A) 220 V-230 V	1	
70	981824	HEX. HD. TAPPING SCREW D4 X 45	2	
*71	341028C	STATOR (A) 110 V (W/CR)	1	

ITEM NO.	CODE NO.	DESCRIPTION	NO. USED	REMARKS
*71	341028K	STATOR (A) 220 V-230 V	1	
72	955203	BRUSH HOLDER	2	
73	999041	CARBON BRUSH (1 PAIR)	1	
74	999072	CARBON BRUSH (AUTO STOP TYPE) (1 PAIR)	1	
75	374615	CHOKE COIL (BROWN)	1	
76	374614	CHOKE COIL (BLUE)	1	
77	322853	PUSHING BUTTON	1	
*78	374611	SWITCH 100 V-127 V	1	
*78	374610	SWITCH 220 V-240 V	1	
79	301654	TAPPING SCREW (W/FLANGE) D5 X 35	4	
*80	500465Z	CORD	1	(CORD ARMOR D8.8)
*80	500446Z	CORD	1	(CORD ARMOR D8.8) FOR GBR (230 V)
81	953327	CORD ARMOR D8.8	1	
82	937631	CORD CLIP	1	
83	984750	TAPPING SCREW (W/FLANGE) D4 X 16	2	
84	930039	NOISE SUPPRESSOR	1	
85	301653	TAPPING SCREW (W/FLANGE) D4 X 20 (BLACK)	3	
86	376296	HOUSING SET	1	
STANDARD ACCESSORIES				
501	377962	CASE	1	
502	374447	SIDE HANDLE	1	
503	303709	DEPTH GAUGE	1	
OPTIONAL ACCESSORIES				
601	306885	DUST COLLECTOR (B) ASS'Y	1	INCLUD. 602, 610
602	986802	DUST COLLECTOR ASS'Y	1	INCLUD. 603-609
603	986803	DUST COVER	1	
604	986804	SEAL COVER	1	
605	948310	RETAINING RING FOR D30 SHAFT	1	
606	958063	WASHER	1	
607	959150	STEEL BALL D6.35 (10 PCS.)	19	
608	986805	OUTER RACE	1	
609	986806	SOCKET	1	
610	306910	SOCKET ADAPTER (B)	1	
611	971787	DUST CUP	1	
612	931844	STOPPER	1	
613	321814	DRILL CHUCK 13VLRB-D	1	INCLUD. 614
614	331966	FLAT HD. SCREW (LEFT HAND) M6 X 20	1	
615	321813	DRILL CHUCK 13VLD-D	1	
616	971511Z	+ DRIVER BIT (A) NO. 2 25L	1	
617	971512Z	+ DRIVER BIT (A) NO. 3 25L	1	
618	971794	ANCHOR SETTING ADAPTER A W1/4" (MANUAL)	1	
619	971795	ANCHOR SETTING ADAPTER A W5/16" (MANUAL)	1	
620	971796	ANCHOR SETTING ADAPTER A W3/8" (MANUAL)	1	
621	971797	ANCHOR SETTING ADAPTER A W1/2" (MANUAL)	1	
622	971798	ANCHOR SETTING ADAPTER A W5/8" (MANUAL)	1	
623	971799	ANCHOR SETTING ADAPTER B W1/4" (MANUAL)	1	
624	971800	ANCHOR SETTING ADAPTER B W5/16" (MANUAL)	1	
625	971801	ANCHOR SETTING ADAPTER B W3/8" (MANUAL)	1	
626	971802	ANCHOR SETTING ADAPTER B W1/2" (MANUAL)	1	
627	971803	ANCHOR SETTING ADAPTER B W5/8" (MANUAL)	1	
628	320859	SYRINGE (BLOW-OUT BULB TYPE)	1	
629	944477	COTTER	1	
630	982684	CENTER PIN (A) 109L FOR CORE BIT D32-38	1	
631	982685	CENTER PIN (B) 104L FOR CORE BIT D45-90	1	
632	335781	GREASE FOR ROTARY HAMMER (500 G)	1	
633	335782	GREASE FOR ROTARY HAMMER (60 G)	1	