

Atomia

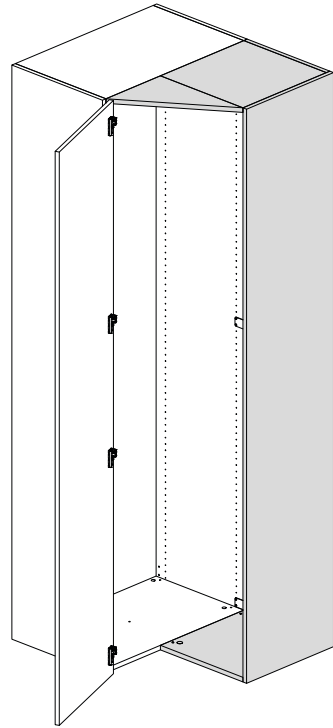
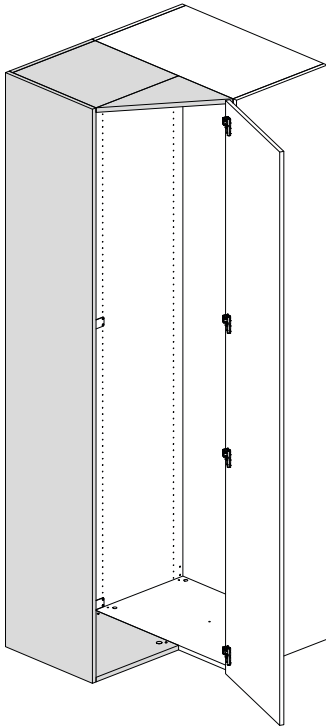
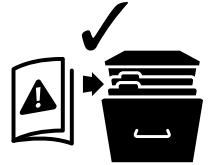

5059340918457 / 5059340918433 / 5059340918440

	EN Contents	FR Contenu	02
	PL Zawartość	RO Produktbeschreibung	
	TR İçindekiler		

Product description **04**

FR	Description du produit	04
PL	Opis produktu	04
RO	Descrierea produsului	04
TR	Ürün açıklaması	04

Safety **05**

FR	Sécurité	06
PL	Bezpieczeństwo	08
RO	Siguranță	10
TR	Emniyet	11

Guarantee **05**

FR	Garantie	07
PL	Gwarancja	09
RO	Garanție	10
TR	Garanti	12

Assembly **13**

FR	Assemblage	13
PL	Montaż	13
RO	Asamblare	13
TR	Montaj	13



EN WARNING! Please read all safety warnings carefully and be sure that they are fully understood before handling the product.

FR AVERTISSEMENT ! Avant de manipuler le produit, il est nécessaire d'avoir lu attentivement et parfaitement compris tous les avertissements de sécurité.

PL OSTRZEŻENIE! Przed przystąpieniem do użytkowania produktu należy dokładnie przeczytać wszystkie ostrzeżenia bezpieczeństwa oraz upewnić się, że zostały w pełni zrozumiane.

RO AVERTISMENT! Citiți cu atenție toate avertismentele de siguranță și asigurați-vă că au fost complet înțelese înainte de manevrarea produsului.

TR UYARI! Lütfen tüm güvenlik uyarılarını dikkatle okuyun ve ürün üzerinde çalışmaya başlamadan önce hepsini iyice anladığınızdan emin olun.

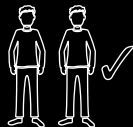

[A] x 8



[B] x 8



[C] x 4



[D] x 40



[E] x 8



[F] x 4



[G] x 4



[H] x 2



[I] x 2



[J] x 1



[K] x 4



[L] x 3

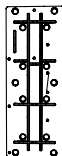

[M] x 3



[N] x 4

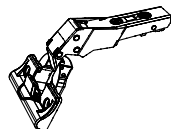

[O] x 4

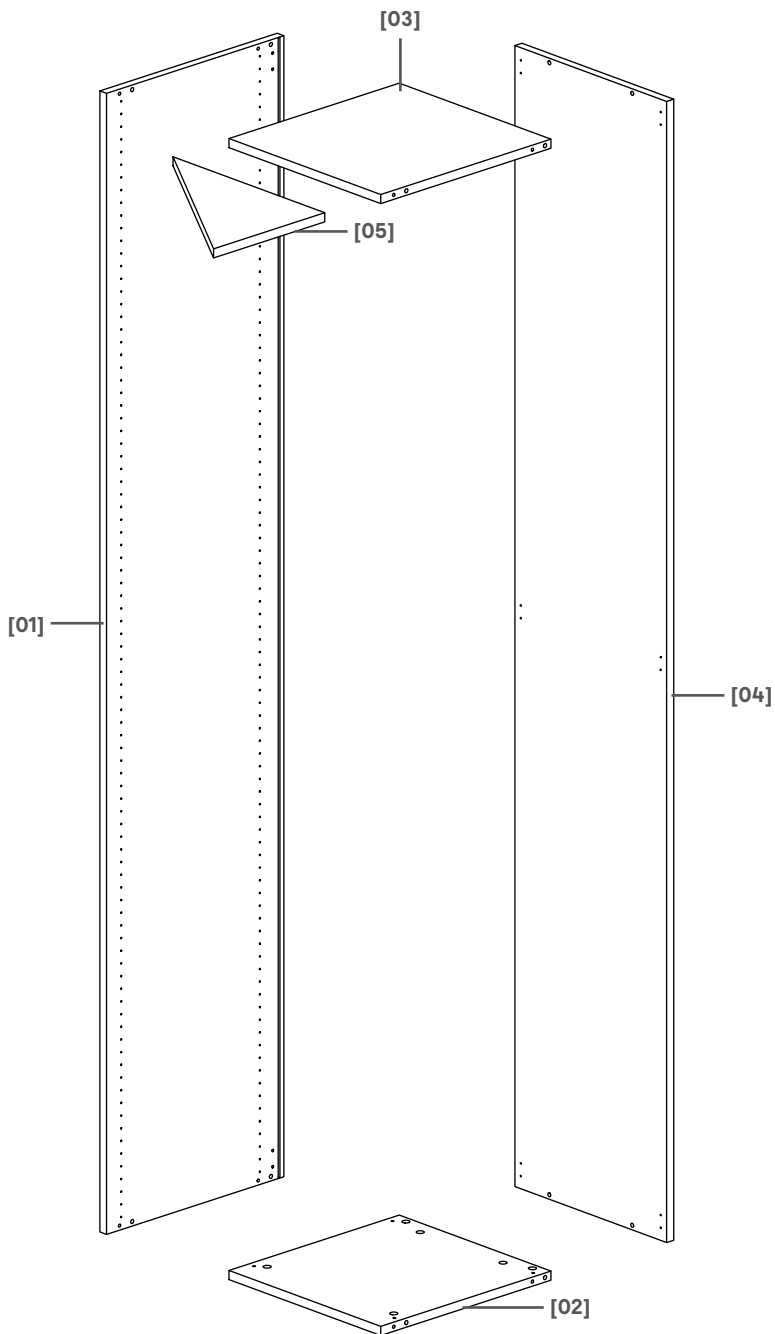



EN Getting Started...

- Check the pack and make sure that you have all parts. If not contact your local store who will be able to help you.
- When you are ready to start, make sure that you have the right tools on hand, plenty of space and a clean dry area for furniture assembly.
- Ensure there are no hidden service pipes and cables where you intended to drill.
- We do not recommend the use of power screwdrivers for the assembly of this product.
- Always ensure that screws locate exactly into pre-drilled pilot holes.
- Take care not to overtighten any of the screws.
- Screws and wall plugs not included.

Safety

- For domestic use only.
- Always use on firm level ground, ensuring that all legs remain in contact with the ground.
- Periodic structural checks of this product should be undertaken, do not use if you have any doubts about its fitness for purpose.
- Do not let children play with this product.

Warning

Installation must be carried out following the manufacturer's instructions exactly.

- If you are in any doubt as to how to install this product, consult a technically competent person.
- **WARNING:** Installation must be performed by a competent person only. This product could be dangerous, cause injury or damage to property if incorrectly installed
- Furniture placed on the floor: In order to prevent any risk of tipping over, this product must be used with the anchoring devices provided.
- Hung furniture: In order to prevent any risk of falling, this product must be used with the wall anchoring device provided.
- Furniture hung on the wall and/or ceiling: Check the solidity of the wall/ceiling to ensure that the anchoring devices will withstand the forces generated.
- Fixing devices for the wall are not included since different wall materials require different types of fixing devices. Use fixing devices suitable for the walls in your home.

Care & Maintenance

- Use a soft dry cloth to clean the surface of your furniture.
- Do not leave any standing water on your furniture. Immediately wipe up any spills or splashes.
- Never use any solvents, scourers, abrasives, bleach, acids, strong detergents, aggressive chemical cleaners or solvent-type cleaning solutions on the product.

Regular checking

Check to ensure that all components and fixings of this product are secure, do not use if you have any doubts about its fitness for purpose.

Guarantee

We take special care to select high quality materials and use manufacturing techniques that allow us to create products incorporating design and durability. This product has a manufacturer's guarantee of 15 years against manufacturing defects, from the date of purchase (if bought in store) or date of delivery (if bought online), at no additional cost for normal (non-professional or commercial) household use.

To make a claim under this guarantee, you must present your proof of purchase (such as a sales receipt, purchase invoice or other evidence admissible under applicable law), please keep your proof of purchase in a safe place. For this guarantee to apply, the product you purchased must be new, it will not apply to second hand or display products. Unless stated otherwise by applicable law, any replacement product issued under this guarantee will only be guaranteed until expiry of the original guarantee period.

This guarantee covers product failures and malfunctions provided the product was used for the purpose for which it is intended and subject to installation, cleaning, care and maintenance in accordance with the information contained in these terms and conditions, in the user manual and standard practice, provided that standard practice does not conflict with the user manual.

This guarantee does not cover defects and damage caused by normal wear and tear or damage that could be the result of improper use, faulty installation or assembly, neglect, accident, misuse,



or modification of the product. Unless stated otherwise by applicable law, this guarantee will not cover, in any case, ancillary costs (shipping, movement, costs of uninstalling and reinstalling, labour etc), or direct and indirect damage. If the product is defective, we will, within a reasonable time, provide spare parts, or proceed with a partial or complete replacement. Rights under this guarantee are enforceable in the country in which you purchased this product. Guarantee related queries should be addressed to the store you purchased this product from. The guarantee is in addition to and does not affect your statutory rights.

IMPORTANT - RETAIN THIS INFORMATION FOR FUTURE REFERENCE: READ CAREFULLY

FR Pour bien commencer...

- Vérifier le contenu du carton et s'assurer qu'il contient toutes les pièces. En cas de pièces manquantes, merci de contacter votre magasin qui sera en mesure de vous aider.
- Avant de commencer, veiller à disposer des outils adaptés, d'un espace suffisant ainsi que d'une surface propre et sèche pour l'assemblage du meuble.
- Vérifier qu'aucun tuyau ou câble n'est dissimulé avant de commencer à percer.
- Nous déconseillons l'utilisation de tournevis électriques pour l'assemblage de ce produit.
- Toujours s'assurer que les vis sont bien positionnées dans les trous pré-perçés.
- Veiller à ne pas trop serrer les vis.
- Vis et chevilles murales non fournies.

Sécurité

- Pour un usage domestique uniquement.
- Toujours travailler sur une surface plane et ferme pour s'assurer que tous les pieds restent en contact avec le sol.
- Une vérification structurelle du produit doit être effectuée régulièrement. Ne pas utiliser le produit en cas de doute sur sa conformité à l'usage.
- Ne pas laisser les enfants jouer avec ce produit.

Avertissement

- L'installation doit être effectuée en respectant parfaitement les instructions du fabricant.
- En cas de doute quant à l'installation de ce produit, faire appel à un expert.
 - **AVERTISSEMENT** : L'installation doit être effectuée par une personne compétente uniquement. Ce produit peut être dangereux et causer des blessures ou des dégâts matériels s'il n'est pas installé correctement.
 - Meuble au sol : Pour éviter tout risque de renversement, ce produit doit être utilisé avec les dispositifs de fixation fournis.
 - Meuble à suspendre : Pour éviter tout risque de chute, ce produit doit être utilisé avec le dispositif de fixation murale fourni.
 - Meuble à suspendre au mur et/ou au plafond : Vérifier la solidité du mur/plafond pour s'assurer que les dispositifs de fixation résisteront aux forces générées.
 - Les dispositifs de fixation au mur ne sont pas inclus dans la mesure où chaque type de mur nécessite des types de dispositifs de fixation différents. Utiliser les dispositifs de fixation adaptés aux murs de votre maison.

Entretien et Maintenance

- Utiliser un chiffon doux et sec pour nettoyer la surface de votre meuble.
- Ne pas laisser d'eau stagner sur votre meuble. Essuyer immédiatement toute trace de déversement ou d'éclaboussures.
- Ne jamais utiliser de solvants, de tampons à récurer, de produits abrasifs, d'eau de Javel, d'acides, de détergents puissants, de produits nettoyants chimiques agressifs ni de solutions de nettoyage à base de solvant pour nettoyer le produit.



Vérification régulière

Vérifier que tous les composants et fixations de ce produit sont bien fixés. Ne pas utiliser le produit en cas de doute sur sa conformité à l'usage.

Garantie

Nous veillons tout particulièrement à sélectionner des matériaux de haute qualité et à utiliser des techniques de fabrication qui nous permettent de créer des produits à la fois design et durables. Ce produit bénéficie d'une garantie fabricant de 15 ans couvrant les défauts de fabrication à compter de la date d'achat (en cas d'achat en magasin) ou de la date de livraison (en cas d'achat sur Internet), sans coût supplémentaire pour une utilisation domestique normale (non commerciale ni professionnelle).

Pour déposer une réclamation au titre de cette garantie, vous devez présenter votre preuve d'achat (ticket de caisse, facture d'achat ou toute autre preuve recevable en vertu de la loi en vigueur). Conservez votre preuve d'achat dans un endroit sûr. Pour que cette garantie soit applicable, le produit que vous avez acheté doit être neuf. La garantie ne s'applique pas aux produits d'occasion ou aux modèles d'exposition. Sauf indication contraire prévue par la loi en vigueur, tout produit de remplacement fourni au titre de la présente garantie ne sera garanti que jusqu'à expiration de la période de garantie initiale.

Cette garantie couvre les défaillances et dysfonctionnements du produit, sous réserve que le produit ait été utilisé conformément à l'usage pour lequel il a été conçu, qu'il ait été installé, nettoyé et entretenu conformément aux informations contenues dans les présentes conditions générales ainsi que dans le manuel d'utilisation, et conformément à la pratique, sous réserve que celles-ci n'aient pas à l'encontre du manuel d'utilisation.

Cette garantie ne couvre pas les défauts et dommages causés par l'usure normale ni les dommages pouvant résulter d'une utilisation non conforme, d'une installation ou d'un assemblage défectueux, ou d'une négligence, d'un accident, d'une mauvaise utilisation ou d'une modification du produit. Sauf indication contraire prévue par la loi en vigueur, cette garantie ne couvre en aucun cas les coûts accessoires (expédition, transport, frais de désinstallation et réinstallation, main d'œuvre, etc.), ni les dommages directs et indirects.

Si le produit est défectueux, nous nous engageons, dans un délai raisonnable, à fournir les pièces de rechange ou à procéder à un échange partiel ou total. Cette garantie est valable dans le pays où vous avez acheté ce produit. Toute demande au titre de la garantie doit être adressée au magasin où vous avez acheté ce produit.

Cette garantie s'ajoute à vos droits au titre de la loi, sans les affecter.

Si vous avez acheté ce produit en France, en plus de cette garantie commerciale, le vendeur reste tenu de respecter la garantie légale de conformité prévue par les articles L217-4 à L217-14 du Code de la consommation et aux articles qui concernent les vices cachés de la chose vendue dans les conditions prévues aux articles 1641 à 1648 et 2232 du Code civil. Le distributeur auprès duquel vous avez acheté ce produit répond de tout défaut de conformité ou vice caché du produit, conformément aux présentes dispositions.

En vertu de l'article L217-16 du Code de la consommation, lorsque l'acheteur demande au vendeur, pendant la durée de la garantie commerciale qui lui a été consentie lors de l'acquisition ou de la réparation d'un bien meuble, une remise en état couverte par la garantie, toute période d'immobilisation d'au moins sept jours vient s'ajouter à la durée de la garantie qui reste à courir. Cette période court à compter de la demande d'intervention de l'acheteur ou de la mise à disposition pour réparation du bien en cause, si cette mise à disposition est postérieure à la demande d'intervention. Garantie légale de conformité (extrait du Code de la consommation) : Article L217-4 du Code de la consommation - Le vendeur doit livrer un bien conforme au contrat et répond des défauts de conformité existant lors de la livraison. Il répond également des défauts de conformité résultant de l'emballage, des instructions de montage ou de l'installation lorsque celle-ci a été mise à sa charge par le contrat ou a été réalisée sous sa responsabilité. Article L217-5 du Code de la consommation - Le bien est conforme au contrat : 1. S'il est adapté à l'objectif généralement prévu pour des biens similaires et, le cas échéant : s'il correspond à la description donnée par le vendeur et possède les qualités présentées par le vendeur à l'acheteur sous forme d'échantillon ou de modèle : s'il présente des qualités que l'acheteur peut légitimement attendre au regard des déclarations publiques faites par le vendeur, par le fabricant ou par son représentant, notamment



dans la publicité ou l'étiquetage ; 2. Ou s'il présente les caractéristiques définies d'un commun accord par les parties ou est propre à tout usage spécial recherché par l'acheteur, porté à la connaissance du vendeur et que ce dernier a accepté. Article L217-12 du Code de la consommation - Toute réclamation suite à un défaut de conformité est limitée à deux ans à compter de la livraison du bien. Garantie légale sur les vices cachés (extrait du Code de la consommation) : Article 1641 du Code civil - Le vendeur est tenu de la garantie en cas de défauts cachés de la chose vendue qui la rendent impropre à l'usage auquel on la destine, ou qui diminuent tellement cet usage que l'acheteur ne l'aurait pas acquise, ou n'en aurait donné qu'un moindre prix, s'il les avait connus. Article 1648 du Code civil (alinéa 1) - Toute réclamation résultant de vices cachés doit être faite par l'acheteur dans un délai de deux ans à compter de la découverte du vice.

IMPORTANT : CONSERVER CES INFORMATIONS POUR CONSULTATION ULTÉRIEURE, À LIRE ATTENTIVEMENT

PL Pierwsze kroki...

- Sprawdzić zawartość opakowania i upewnić się, że wszystkie elementy zostały dostarczone. Jeśli nie, należy skontaktować się z lokalnym sklepem, który udzieli pomocy.
- Przed rozpoczęciem pracy należy upewnić się, że wszystkie narzędzia są pod ręką, a miejsce montażu mebli jest czyste, suche i wystarczająco duże.
- Upewnić się, że w miejscu, w którym ma zostać wywiercony otwór, nie ma żadnych ukrytych rur ani kabli.
- Do montażu tego produktu nie zaleca się używania wkrętaków elektrycznych.
- Zawsze sprawdzać, czy wkręty są dokładnie wkręcone we wstępnie nawiercone otwory prowadzące.
- Uważać, aby zbyt mocno nie dokręcić wkrętów. Zestaw nie zawiera wkrętów ani kołków do ściany.

Bezpieczeństwo

- Wyłącznie do użytku w gospodarstwie domowym.
- Należy zawsze używać produktu na twardej, poziomej powierzchni, upewniając się, że wszystkie jego nogi stykają się z podłożem.
- Należy okresowo sprawdzać stan produktu, a w przypadku jakichkolwiek wątpliwości dotyczących przydatności do określonego celu nie należy go użytkować.
- Nie należy pozwalać dzieciom bawić się produktem.

Ostrzeżenie

Montaż musi zostać wykonany dokładnie według instrukcji producenta.

- W przypadku jakichkolwiek wątpliwości dotyczących montażu produktu należy skontaktować się z wykwalifikowanym technikiem.
- **OSTRZEŻENIE:** Montaż produktu powinna przeprowadzać wyłącznie wykwalifikowana osoba. W przypadku nieprawidłowego montażu produkt może stanowić niebezpieczeństwo, spowodować obrażenia lub uszkodzenia mienia.
- Meble stojące: Aby zapobiec przewróceniu produktu, należy używać go wraz z dołączonymi kotwami ściennymi.
- Meble ścienne: Aby uniknąć ryzyka upadku, produkt należy stosować wraz z dołączoną kotwą ścienną.



- Meble zawieszane na ścianie lub suficie: Sprawdź solidność ściany/sufitu, aby upewnić się, że kotwy ściennie wytrzymają generowane obciążenie.
- Zestaw nie zawiera mocowań ściennych, ponieważ ich rodzaj zależy od materiału, z którego są wykonane ściany. Należy używać mocowań przeznaczonych do ścian znajdujących się w domu.

Czyszczenie i Konserwacja

- Do czyszczenia powierzchni mebli należy używać miękkiej, suchej ściereczki.
- Nie pozostawiać na powierzchni mebli rozlanej wody. Natychmiast wycierać mokre plamy i zachłapania.
- Do czyszczenia produktu nie należy używać żadnych rozpuszczalników, czyszcików drucianych, materiałów ściernych, wybielaczy, kwasów, silnych detergentów i żrących chemicznych środków czyszczących ani też środków czyszczących typu rozpuszczalnikowego.

Regularne sprawdzanie

Należy sprawdzić, czy wszystkie części i elementy mocujące produktu są dokręcone. Nie używać w przypadku jakichkolwiek wątpliwości dotyczących jego przydatności do określonego celu.

Gwarancja

Przykładamy szczególną wagę do tego, aby wybierać materiały wysokiej jakości i stosować techniki produkcyjne, które umożliwiają tworzenie wytrzymałych, a zarazem atrakcyjnych produktów. Ten produkt ma gwarancję producenta na 15 lat, która obejmuje wady produkcyjne, począwszy od daty zakupu (zakup w sklepie) lub dostawy (zakup przez Internet) bez dodatkowych kosztów w przypadku normalnego (nieprofesjonalnego lub niekomercyjnego) użytku domowego.

Aby dokonać zgłoszenia reklamacyjnego, należy przedstawić dowód zakupu (np. paragon, fakturę lub inny dowód na mocy obowiązujących przepisów prawa). Dowód zakupu należy przechowywać w bezpiecznym miejscu. Gwarancja obejmuje produkty nowe; nie obejmuje produktów używanych lub z ekspozycji. Produkt zamienny objęty niniejszą gwarancją będzie nią objęty aż do wygaśnięcia okresu obowiązywania gwarancji oryginalnego produktu, chyba że określono inaczej w obowiązujących przepisach prawa.

Niniejsza gwarancja obejmuje wady i uszkodzenia produktu, pod warunkiem że produkt był używany zgodnie z przeznaczeniem oraz zamontowany, czyszczony i konserwowany zgodnie z informacjami zawartymi powyżej oraz w instrukcji obsługi, a także ze standardowymi praktykami (jeśli te praktyki nie są sprzeczne z instrukcją użytkownika).

Niniejsza gwarancja nie obejmuje wad ani uszkodzeń wynikających z normalnego zużycia lub uszkodzeń będących skutkiem niewłaściwego używania, montażu lub złożenia, a także zaniedbania, wypadku i modyfikacji produktu. Gwarancja nie obejmuje w żadnym wypadku dodatkowych kosztów (transportu, przenoszenia, montażu i demontażu, robocizny itd.) ani strat bezpośrednich lub pośrednich, chyba że określono inaczej w obowiązujących przepisach prawa.

Jeśli produkt jest wadliwy, we właściwym czasie zapewnimy części zamienne lub dokonamy częściowej lub całkowitej wymiany.

Prawa wynikające z tej gwarancji obowiązują w kraju, w którym zakupiono produkt. Zapytania dotyczące gwarancji powinno się kierować do sklepu, w którym zakupiono produkt.

Niniejsza gwarancja jest dokumentem dodatkowym, który nie ma wpływu na ustawowe prawa konsumenta.

Jeśli produkt zakupiono w Polsce, niniejsza gwarancja nie wyklucza, nie ogranicza ani nie zawiesza uprawnień wynikających z przepisów prawa dotyczących gwarancji na wady zakupionego towaru.

**WAŻNE – NINIEJSZY
DOKUMENT NALEŻY
ZACHOWAĆ DO
WYKORZYSTANIA
W PRZYSZŁOŚCI:
UWAŻNIE
PRZECZYTAĆ**



RO Pentru început...

- Verificați ambalajul și asigurați-vă că aveți toate piesele. În caz contrar, contactați magazinul local pentru a primi ajutor.
- Când sunteți gata să începeți, asigurați-vă că aveți uneltele potrivite la îndemână, suficient spațiu și o zonă uscată și curată pentru asamblarea mobilierului.
- Asigurați-vă că nu există țevi de serviciu și cabluri ascunse în locul în care intenționați să găuriți.
- Nu recomandăm utilizarea șurubelnițelor electrice pentru asamblarea acestui produs.
- Asigurați-vă întotdeauna că șuruburile sunt amplasate exact în orificiile de ghidare efectuate în prealabil.
- Aveți grijă să nu strângeți prea mult șuruburile.
- Șuruburile și diblurile nu sunt incluse.

Siguranță

- Numai pentru uz casnic.
- Utilizați întotdeauna pe o suprafață plană și tare, asigurându-vă că toate picioarele rămân în contact cu solul.
- Trebuie efectuate verificări structurale periodice pentru acest produs; nu folosiți produsul dacă nu sunteți sigur că este adecvat pentru utilizare.
- Nu lăsați copiii să se joace cu acest produs.

Avertisment

Montarea trebuie efectuată respectând întocmai instrucțiunile producătorului.

- Dacă aveți îndoieli cu privire la montarea produsului, consultați o persoană cu competențe tehnice.
- **AVERTISMENT:** Montarea trebuie efectuată numai de o persoană competentă. Acest produs ar putea fi periculos, ar putea provoca leziuni sau daune materiale dacă nu este montat corect.
- Mobilier așezat pe pardoseală: Acest produs trebuie utilizat cu dispozitivele de fixare furnizate pentru a preveni riscul de răsturnare.
- Mobilier suspendat: Acest produs trebuie utilizat cu dispozitivul de fixare pe perete furnizat pentru a preveni riscul de cădere.
- Mobilier suspendat pe perete și/sau tavan: Verificați rezistența peretelui/tavanului pentru a vă asigura că dispozitivele de fixare vor susține greutatea generată.

- Dispozitivele de fixare pentru perete nu sunt incluse, deoarece materialele diferite ale pereților necesită tipuri diferite de dispozitive de fixare. Utilizați dispozitive de fixare potrivite pentru pereții din locuința dvs.

Îngrijire și întreținere

- Utilizați o cârpă moale uscată pentru a curăța suprafața mobilierului.
- Nu lăsați apa să stagneze pe mobilier. Ștergeți imediat lichidele vărsate sau stropii.
- Nu utilizați niciodată solvenți, degresori, produse abrazive, înălbitor, acizi, detergenți puternici, produse de curățare chimice agresive sau soluții de curățare de tip solvenți pe produs.

Verificare periodică

Efectuați verificări pentru a vă asigura că toate componentele și elementele de fixare ale acestui produs sunt sigure și nu utilizați produsul dacă nu sunteți sigur că este adecvat pentru utilizare.

Garanție

Avem o grijă deosebită să selectăm materiale de înaltă calitate și să utilizăm tehnici de fabricare care ne permit să creăm produse care încorporează designul și durabilitatea. Acest produs beneficiază de garanție din partea producătorului de 15 ani pentru defectele de fabricație, de la data achiziției (dacă este cumpărat din magazin) sau de la data livrării (dacă este cumpărat online), fără niciun cost suplimentar pentru uz casnic normal (nu profesional sau comercial).

Pentru a efectua o solicitare în temeiul acestei garanții, trebuie să prezentați dovada achiziției (cum ar fi, chitanța de vânzare/bonul fiscal, factura de achiziție sau alte dovezi admisibile conform legii aplicabile); vă rugăm să păstrați dovada achiziției într-un loc sigur. Pentru ca această garanție să se aplice, produsul achiziționat trebuie să fie nou, garanția neaplicându-se pentru produse la mâna a doua sau produse de prezentare. Cu excepția cazului în care legislația aplicabilă prevede altfel, orice produs înlocuitor livrat în baza prezentei garanții va beneficia de garanție doar până la expirarea perioadei inițiale de garanție.

Prezenta garanție acoperă defecțiunile produsului și erorile de funcționare, cu condiția ca produsul să fi fost utilizat în scopul prevăzut și să fi fost



instalat, curățat, îngrijit și întreținut în conformitate cu informațiile conținute în termenii și condițiile prezente, manualul de utilizare și practicile standard, cu condiția ca practicile standard să nu fie în contradicție cu manualul de utilizare.

Această garanție nu acoperă defectele și deteriorările provocate de uzura normală sau daunele care pot fi rezultatul utilizării necorespunzătoare, instalării sau asamblării defectuoase, neglijenței, accidentelor, utilizării greșite sau modificărilor aduse produsului. Cu excepția cazului în care legislația aplicabilă prevede altfel, prezenta garanție nu va acoperi, în niciun caz, costurile suplimentare (de expediere, deplasare, dezinstalare și reinstalare, manoperă etc.) sau daunele directe și indirecte.

Dacă produsul este defect, vom proceda, într-un timp rezonabil, la oferirea pieselor de schimb sau înlocuirea parțială sau completă a acestuia.

Drepturile acoperite de această garanție sunt aplicabile în țara în care ați achiziționat produsul.

Întrebările legate de garanție trebuie adresate magazinului de la care ați achiziționat produsul.

Garanția este suplimentară drepturilor dvs. legale și nu le afectează.

Dacă achiziționați acest produs din Turcia sau România, veți primi o garanție.

IMPORTANT - PĂSTRAȚI ACESTE INFORMAȚII PENTRU CONSULTARE ULTERIOARĂ: CITIȚI CU ATENȚIE

TR Başlarken...

- Paketi kontrol edin ve parçaların tamamının bulunduğundan emin olun. Aksi takdirde yerel mağazanızla iletişime geçin. Mağazanız size yardımcı olacaktır.
- Başlamaya hazır olduğunuzda doğru aletlere sahip olduğunuzdan, bol miktarda yerinizin ve mobilya montajı için temiz, kuru bir alanın bulunduğundan emin olun.
- Delmek istediğiniz konumda gizlenmiş altyapı boruları ve kabloları olmadığından emin olun.
- Bu ürünün montajında elektrikli tornavida kullanılmasını önermiyoruz.
- Vidaların her zaman önceden açılmış kılavuz deliklere tam olarak oturduğundan emin olun.
- Vidaların hiçbirini aşırı sıkılamaya dikkat edin.
- Vidalar ve dübeller dahil değildir.

Emniyet

- Sadece evsel kullanıma yöneliktir.
- Daima sağlam düz bir zeminde kullanarak tüm ayakların zeminle temas etmesini sağlayın.
- Bu ürünün düzenli yapı kontrolleri yapılmalıdır, amaca uygun olup olmadığına dair endişeniz varsa ürünü kullanmayın.
- Çocukların bu ürünle oynamasına izin vermeyin.

Uyarı

Montaj işlemi, üreticinin talimatlarına harfiyen uyularak gerçekleştirilmelidir.

- Bu ürünün montajıyla ilgili aklınıza takılan bir şey varsa teknik açıdan yetkin bir kişiye danışın.
- **UYARI:** Montaj işlemi yalnızca yetkin bir kişi tarafından yapılmalıdır. Bu ürünün yanlış kurulması tehlike arz edebilir, kişisel yaralanmaya veya mülk hasarına sebep olabilir.
- Yere koyulan mobilya: Devrilme riskini ortadan kaldırmak için bu ürün birlikte verilen sabitleme cihazları ile kullanılmalıdır.
- Asılan mobilya: Düşme riskini ortadan kaldırmak için bu ürün, birlikte verilen duvara sabitleme cihazları ile kullanılmalıdır.
- Duvara ve/veya tavana asılan mobilya: Sabitleme cihazlarının ortaya çıkacak kuvveti kaldırıp kaldıramayacağını ölçmek için duvarın veya tavanın sağlamlığını kontrol edin.



- Farklı duvar malzemeleri farklı sabitleme cihazları gerektirdiğinden duvar sabitleme cihazları dahil değildir. Evinizin duvarlarına uygun sabitleme cihazları kullanın.

Bakım ve Onarım

- Mobilyalarınızın yüzeyini yumuşak ve kuru bir bezle temizleyin.
- Mobilyalarınızın üzerinde durgun su bırakmayın. Dökülme veya sıçramaları derhal silin.
- Ürün üzerinde çözücü, bulaşık süngeri, aşındırıcı, çamaşır suyu, asit, güçlü deterjan, agresif kimyasal temizleyiciler veya çözücü tipi temizleme solüsyonları kullanmayın.

Düzenli kontrol

Bu ürünün tüm bileşenlerinin ve bağlantı elemanlarının sağlam olduğundan emin olun; amacına uygun olup olmadığına dair bir şüpheniz varsa ürünü kullanmayın.

Garanti

Yüksek kaliteli malzemeler seçmeye ve tasarım ile dayanıklılığı bir arada sunan ürünler ortaya çıkarmamızı sağlayan üretim tekniklerini kullanmaya özen gösteririz. Bu ürün üretim hatalarına karşı, (mağazadan alındıysa) satın alma tarihinden veya (internet üzerinden alındıysa) teslimat tarihinden itibaren normal ev kullanımı için (profesyonel veya ticari olmayan) ek bir maliyet olmadan üreticinin sağladığı 15 yıllık garanti süresine sahiptir.

Bu garanti süresi kapsamında talepte bulunmak için ürünü satın aldıgınıza dair bir kanıt sunmalısınız (satış makbuzu, fatura veya yürürlükteki kanun kapsamında kabul edilebilecek başka bir kanıt), lütfen satın alma kanıtınızı güvenli bir yerde muhafaza edin. Bu garantinin geçerli olması için satın aldıgınız ürünün yeni olması gerekir, ikinci el veya teşhir ürünleri bu kapsamda değildir. Yürürlükteki kanunda aksi belirtilmedikçe bu garanti kapsamında verilen herhangi bir ikame ürüne yalnızca orijinal ürünün garanti süresi bitimine kadar garanti verilir.

Bu garanti; ürünün amacına uygun kullanılmış olması ve montajı, temizliği, bakımı ve muhafazasının bu hüküm ve koşullarda, kullanıcı kılavuzunda yer alan bilgiler ve kullanıcı kılavuzuyla çelişmemesi kaydıyla standart uygulama uyarınca yapılmış olması şartıyla ürün arızalarını ve kusurlarını kapsar.

Bu garanti; normal aşınma ve eskime nedeniyle oluşan kusurlar ile hasarları veya yanlış kullanım, yanlış kurulum veya montaj, ihmal, kaza, kötü kullanım ve ürünün hatalı şekilde değiştirilmesinden doğan hasarları kapsamaz. Yürürlükteki kanunda aksi belirtilmedikçe bu garanti hiçbir koşulda ek maliyetleri (sevkiyat, taşıma, sökme ve yeniden montaj, işçilik vs.) veya doğrudan ve dolaylı hasarları kapsamaz.

Ürün kusurluysa makul bir süre içinde yedek parçaları temin eder veya kısmi ya da tam bir değiştirme işlemiyle devam ederiz.

Bu garanti kapsamındaki haklar, ürünün satın alındığı ülke için geçerlidir. Garantiye ilişkin sorular, bu ürünün satın aldıgınız mağazaya yönlendirilmelidir.

Garanti, temel haklarınızla ilave olarak verilir ve temel haklarınızı etkilemez.

Bu ürünü Türkiye'den veya Romanya'dan satın aldıysanız tarafınıza bir garanti belgesi sunulacaktır.

**ÖNEMLİ: BU
BİLGİLERİ
DİKKATLİCE
OKUYUN VE
DAHA SONRA
BAŞVURMAK
ÜZERE SAKLAYIN**



EN Assembly
PL Montaż
TR Montaj

FR Assemblage
RO Asamblare

13

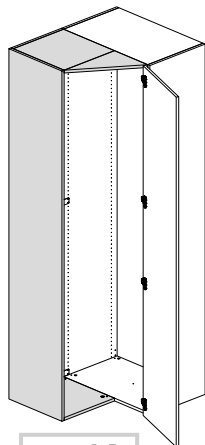
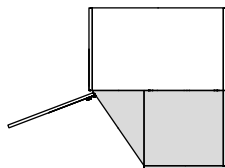
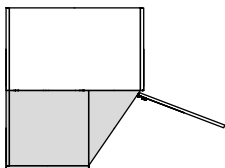

→ 1A

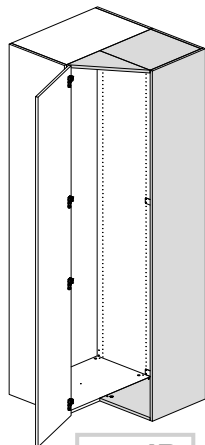

→ 1B



1A



[01] x 1

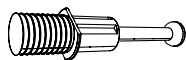

[A] x 4



[C] x 4

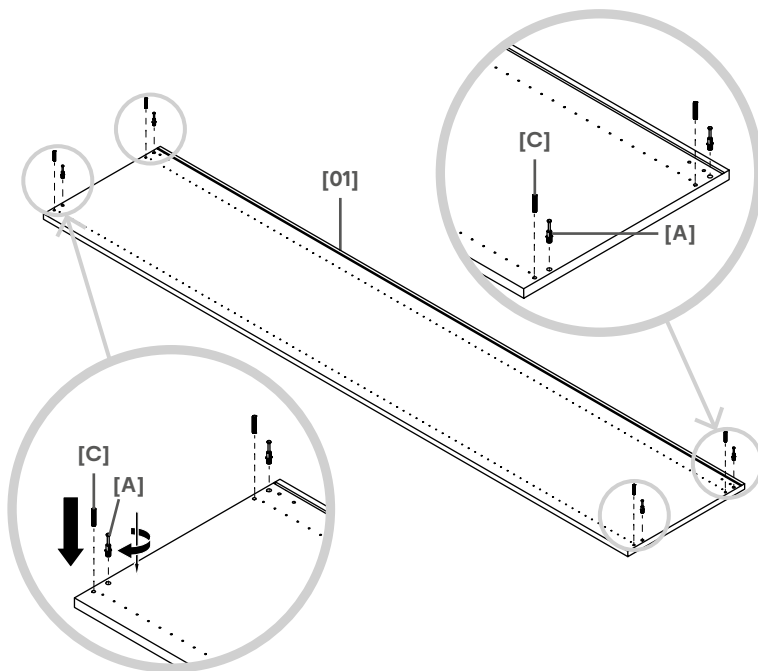



EN Assembly
PL Montaż
TR Montaj

FR Assemblage
RO Asamblare

2A

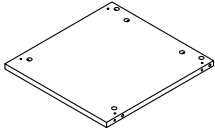

[02] x 1



[D] x 2



[K] x 1

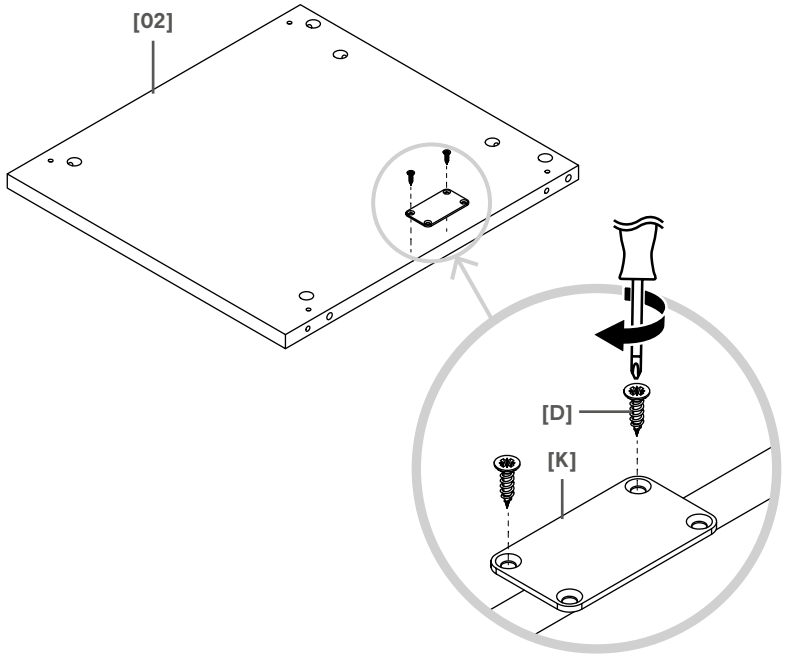

3A

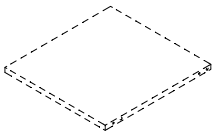

[03] x 1



[D] x 3

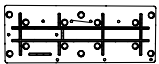

[M] x 1

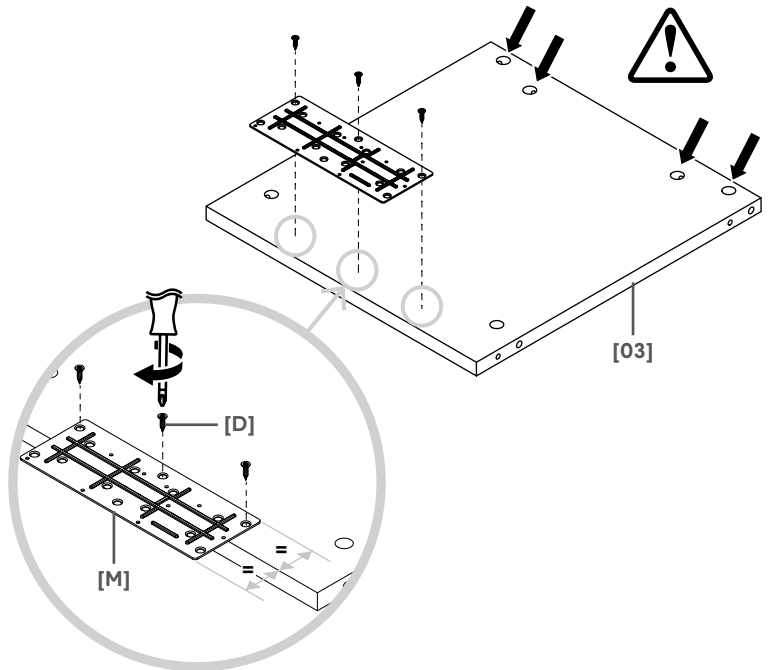



EN Assembly
PL Montaż
TR Montaj

FR Assemblage
RO Asamblare

4A

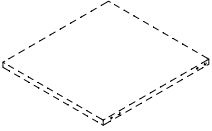

[03] x 1



[D] x 3

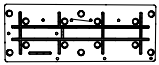

[M] x 1

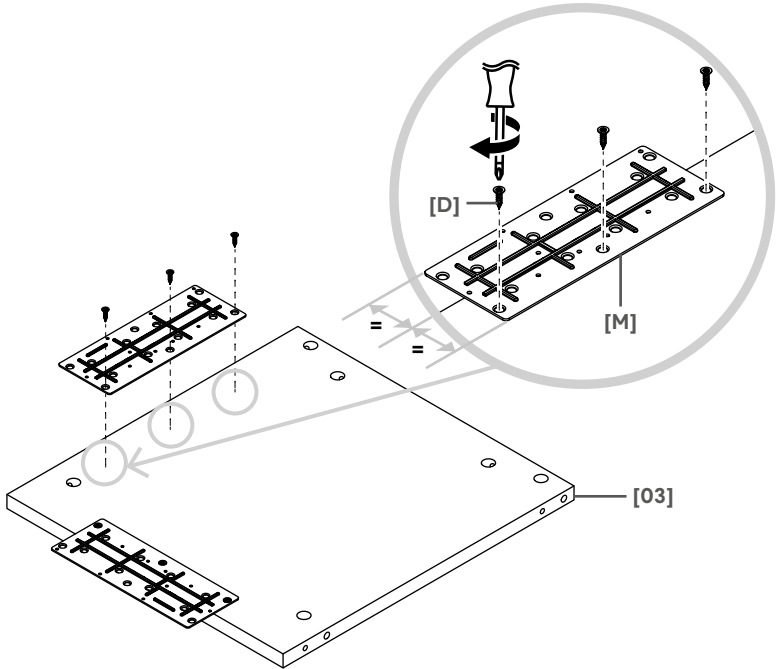

5A



[01] x 1

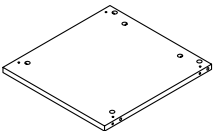

[02] x 1

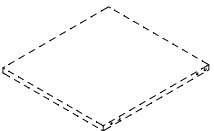

[03] x 1

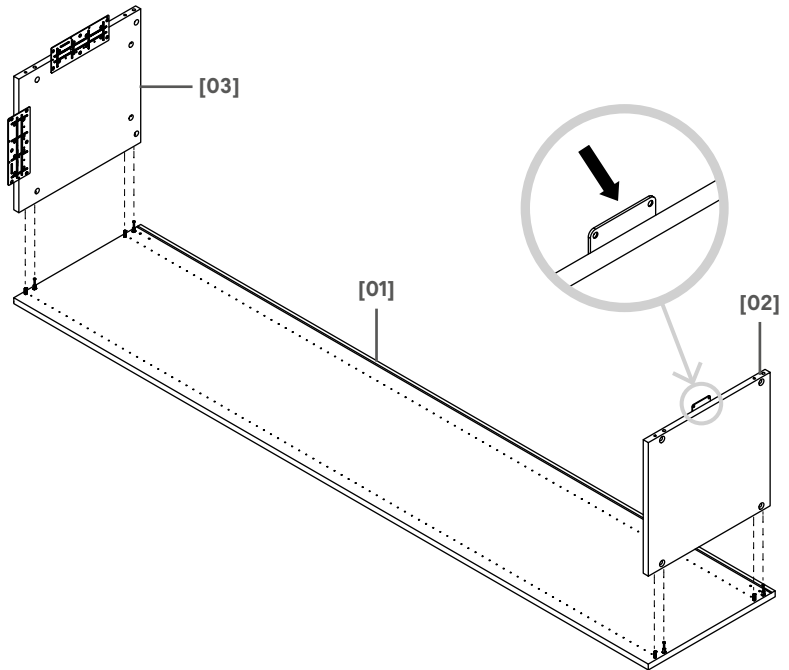



EN Assembly
PL Montaż
TR Montaj

FR Assemblage
RO Asamblare

6A



[B] x 4

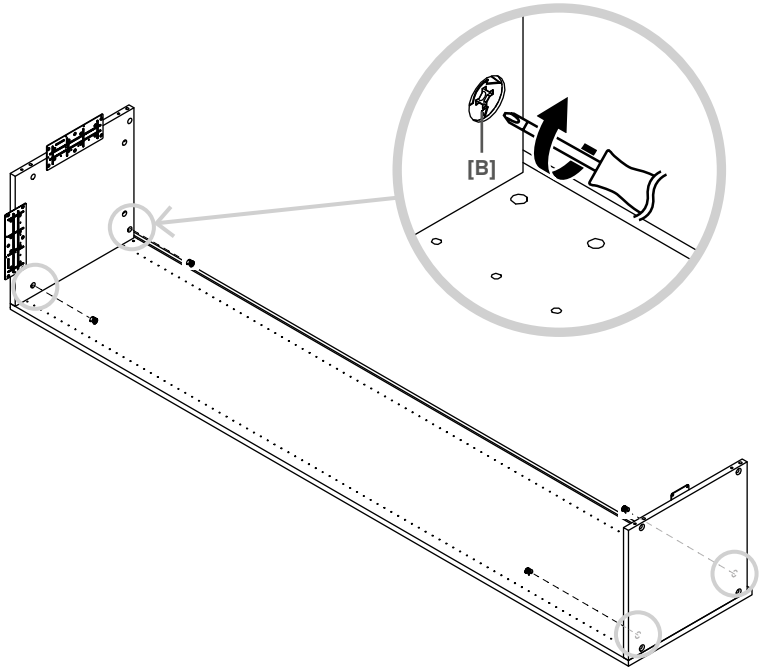

7A

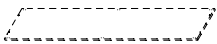

[04] x 1

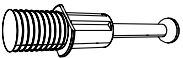

[A] x 4

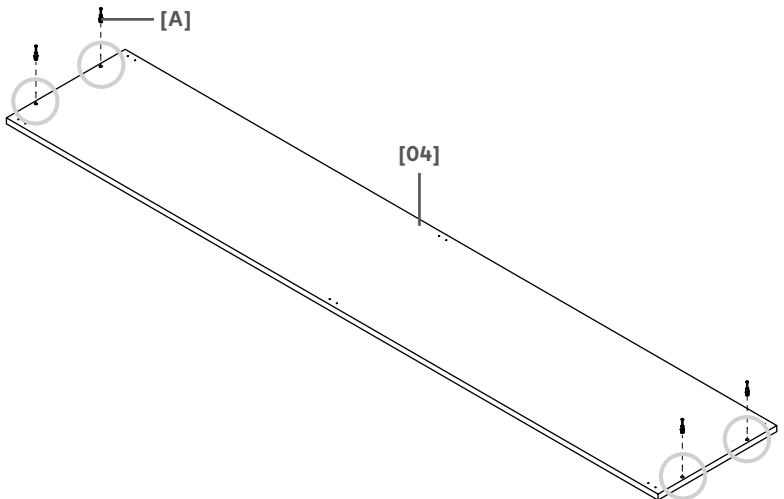



EN Assembly
PL Montaż
TR Montaj

FR Assemblage
RO Asamblare

8A

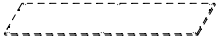

[04] x 1



[D] x 6



[K] x 3

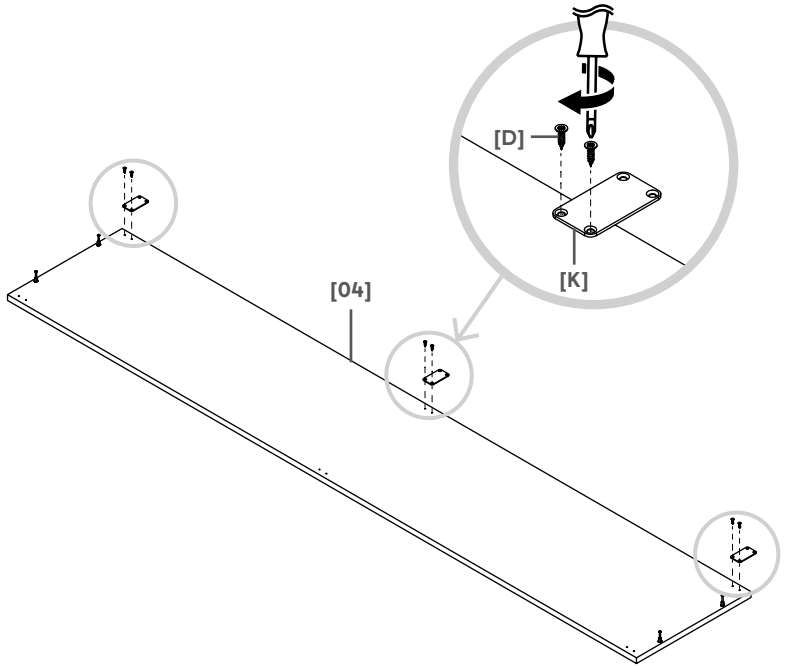

9A

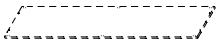

[04] x 1

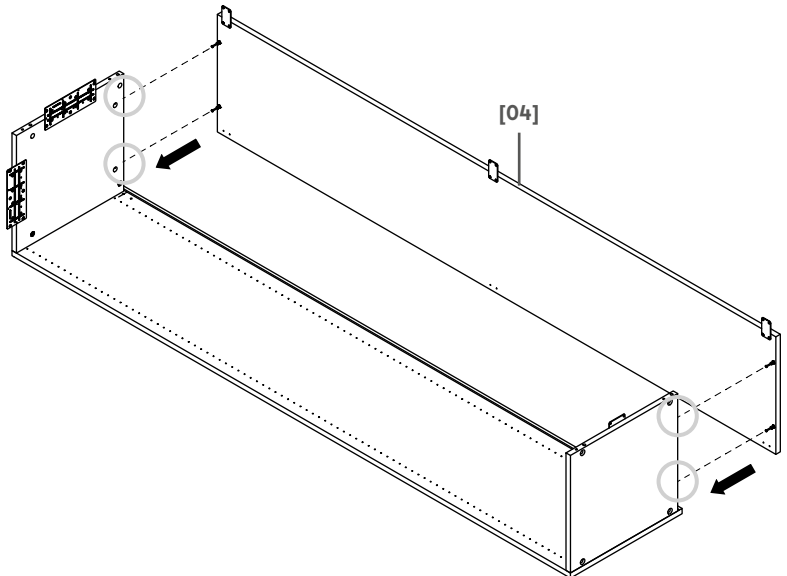



EN Assembly
PL Montaż
TR Montaj

FR Assemblage
RO Asamblare

18

10A



[B] x 4

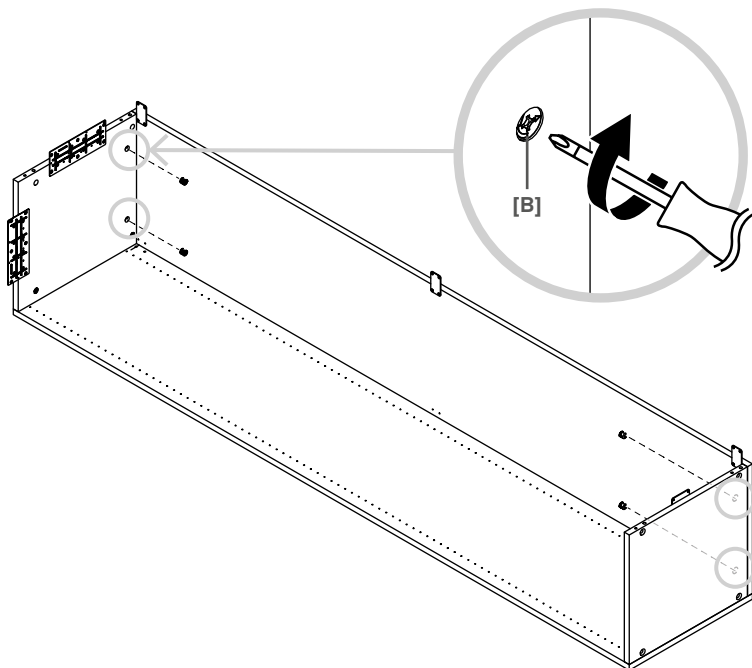

11A

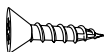

[D] x 6



[L] x 3

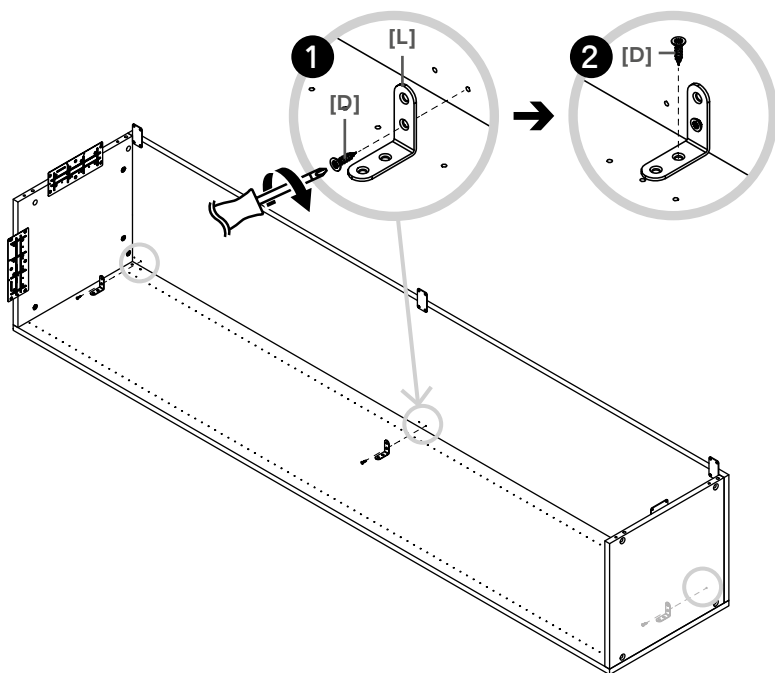



EN Assembly
PL Montaż
TR Montaj

FR Assemblage
RO Asamblare

19

12A



[H] x 2



[I] x 2

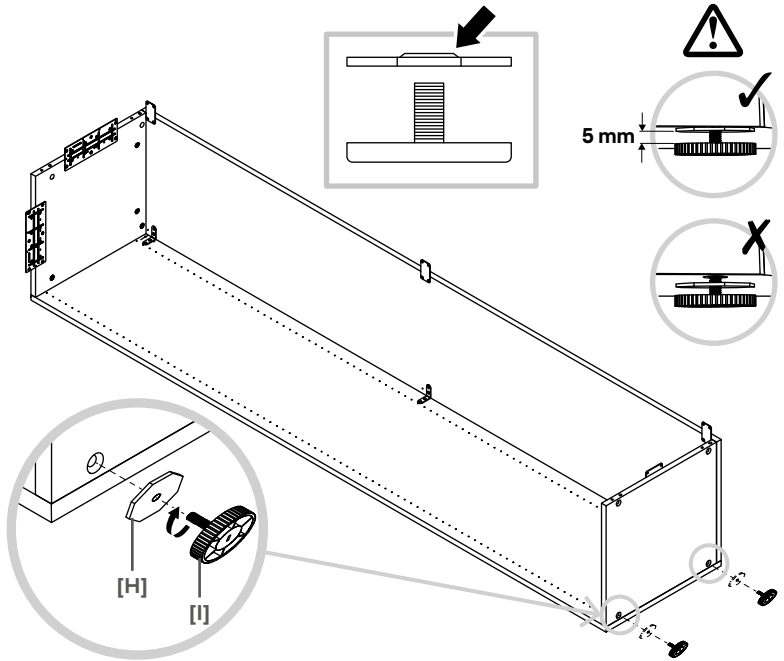

13A

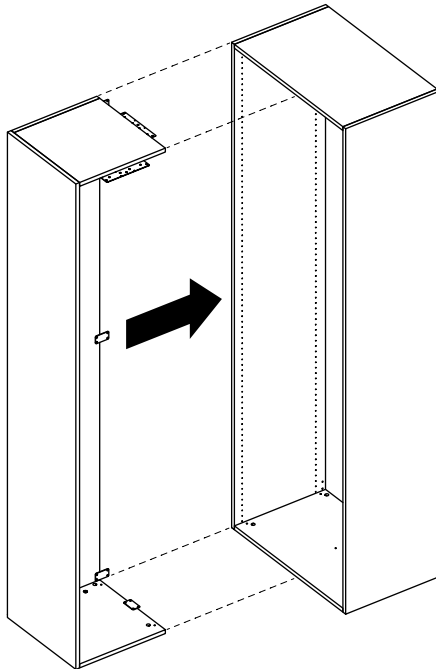



14A



[D] x 8

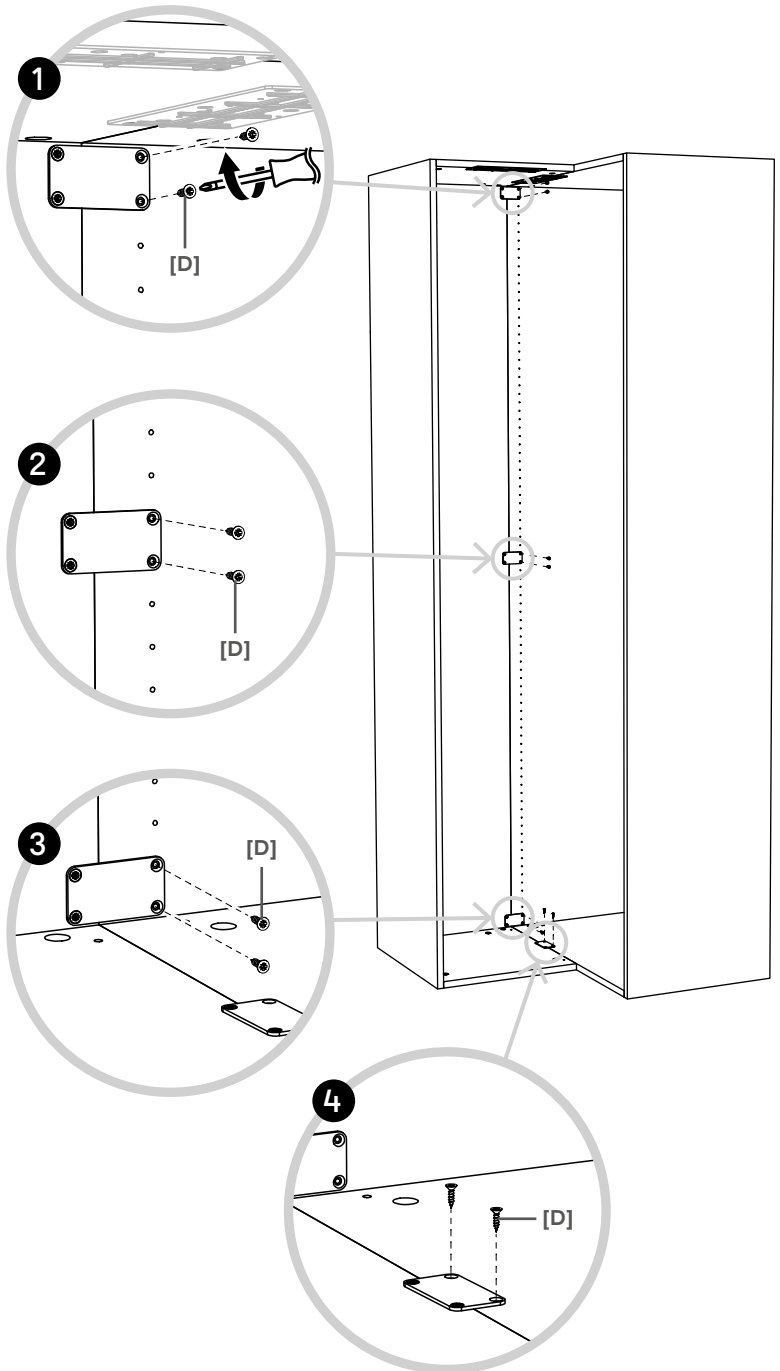



EN Assembly
PL Montaż
TR Montaj

FR Assemblage
RO Asamblare

15A



[D] x 3

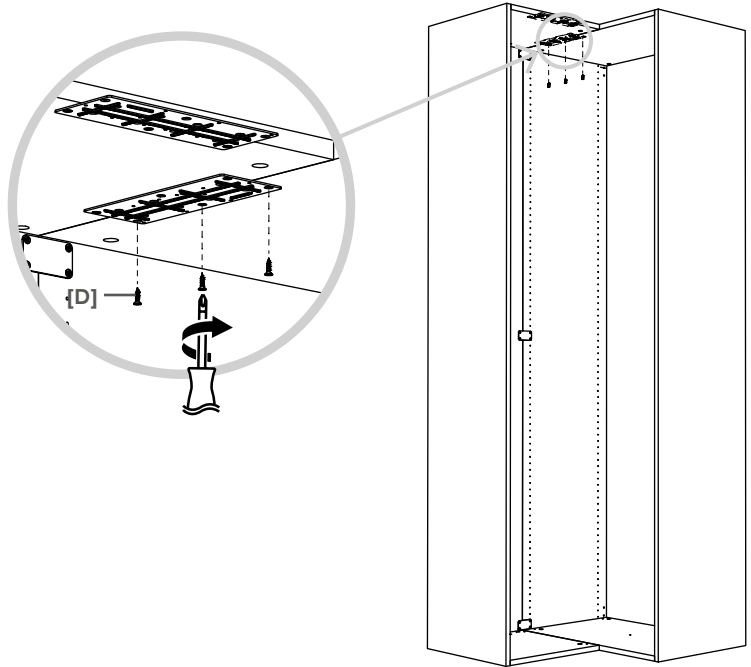

16A

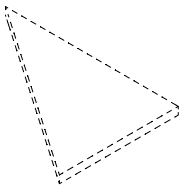

[05] x 1

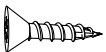

[D] x 3



[M] x 1

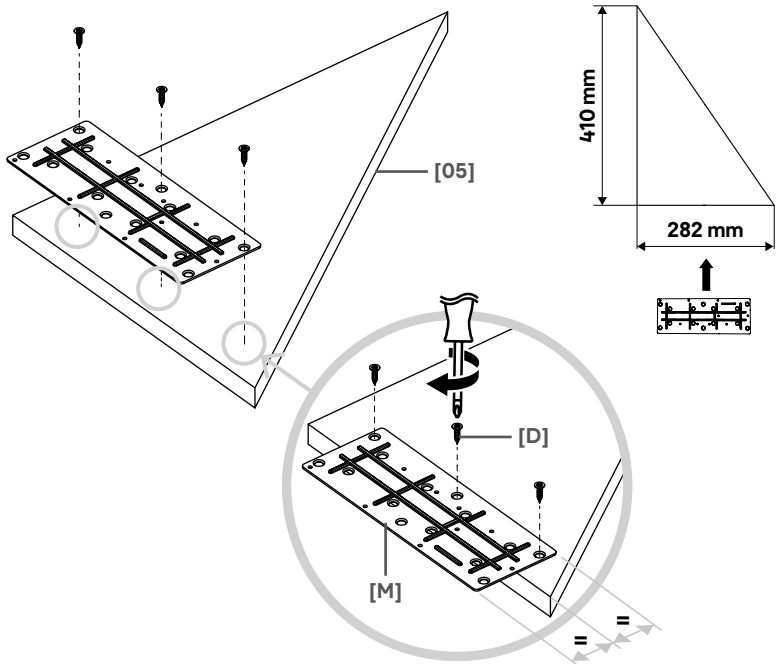



EN Assembly
PL Montaż
TR Montaj

FR Assemblage
RO Asamblare

22

17A

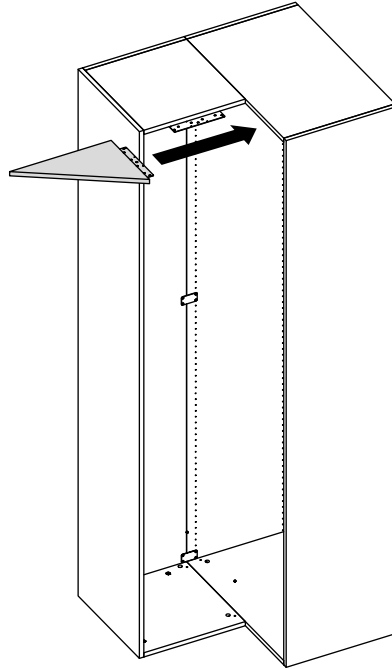

18A



[D] x 6

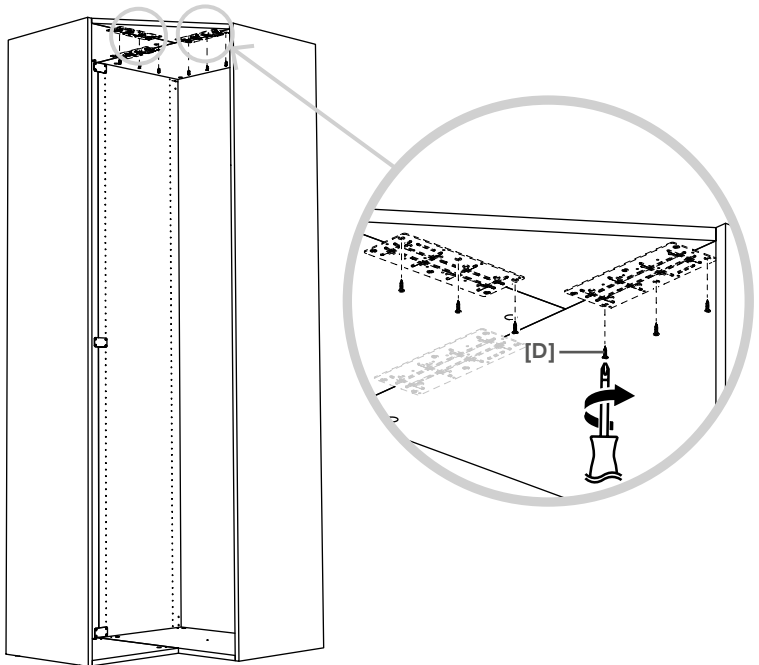



EN Assembly
PL Montaż
TR Montaj

FR Assemblage
RO Asamblare

23

19A



[J] x 1

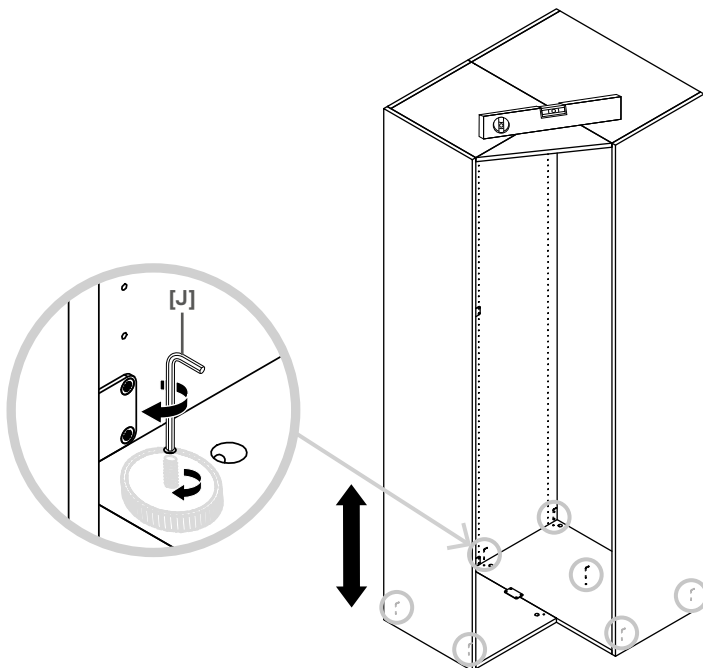

20A



[E] x 8

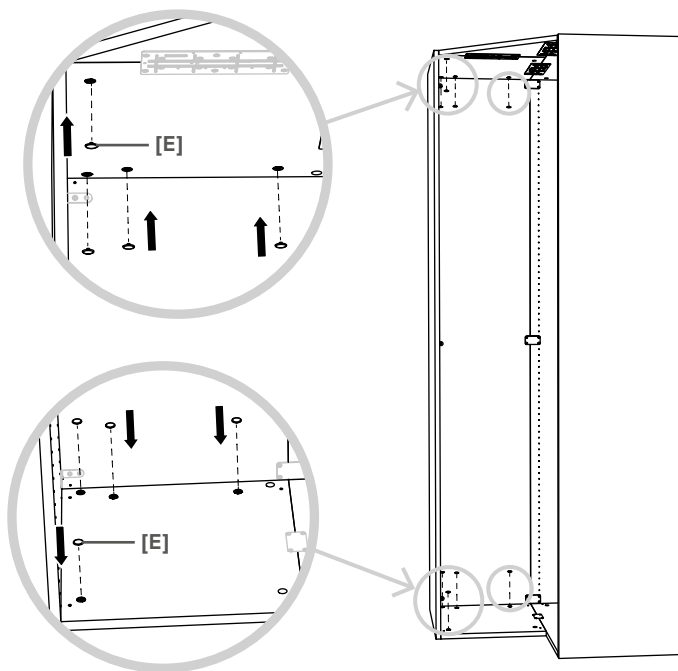



EN Assembly
PL Montaż
TR Montaj

FR Assemblage
RO Asamblare

21A



[F] x 4

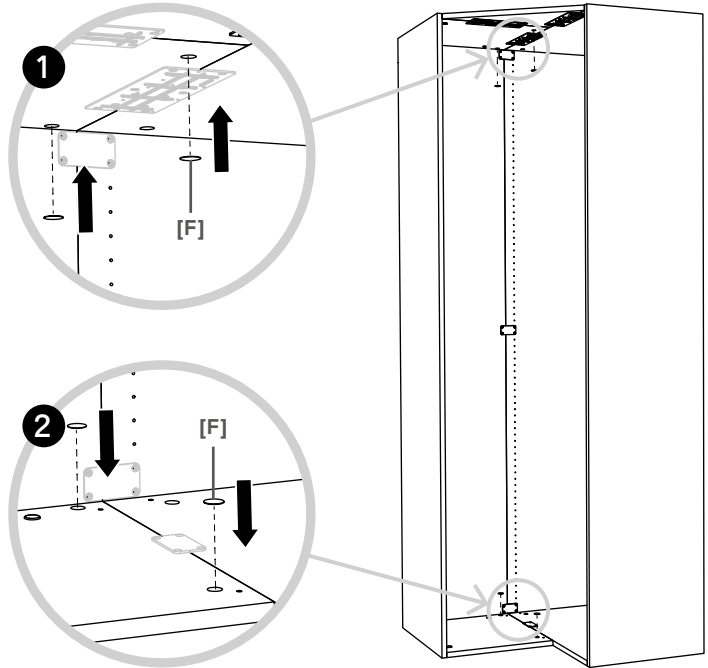

22A



[G] x 4

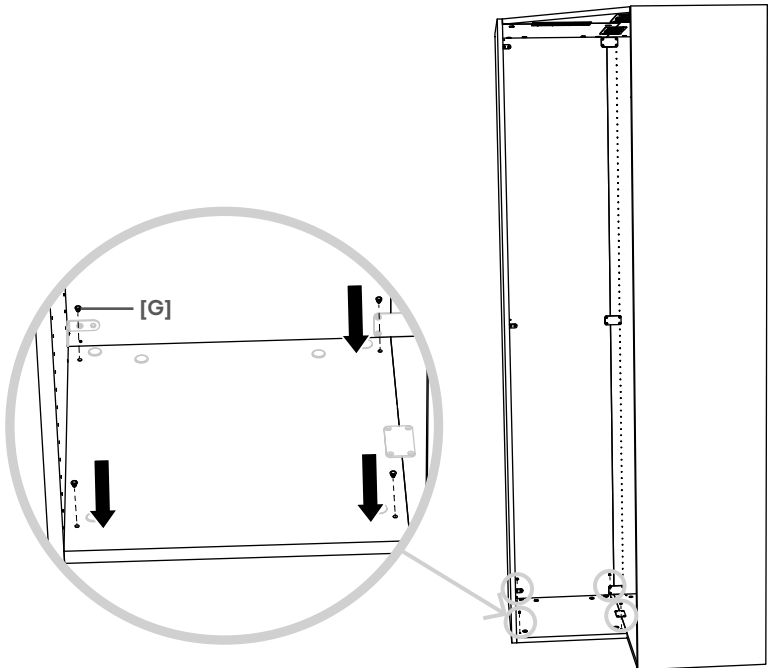



23A

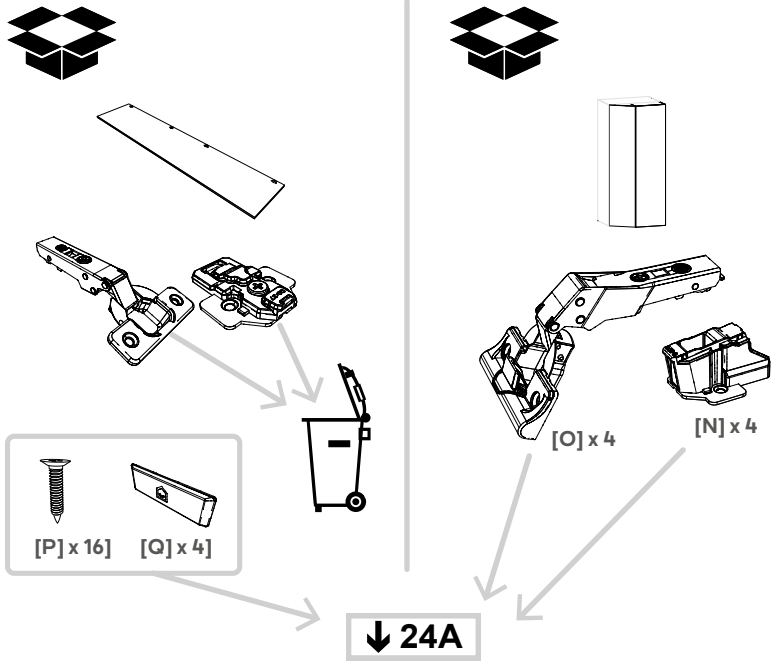

24A

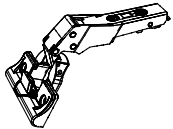
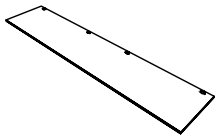

[O] x 4



[P] x 8

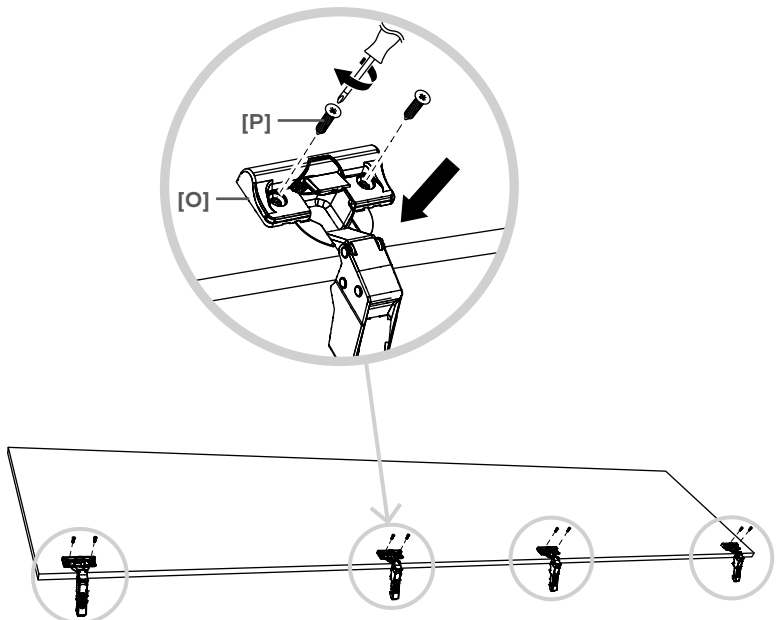



EN Assembly
PL Montaż
TR Montaj

FR Assemblage
RO Asamblare

25A



[N] x 4

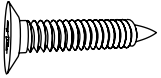

[P] x 8

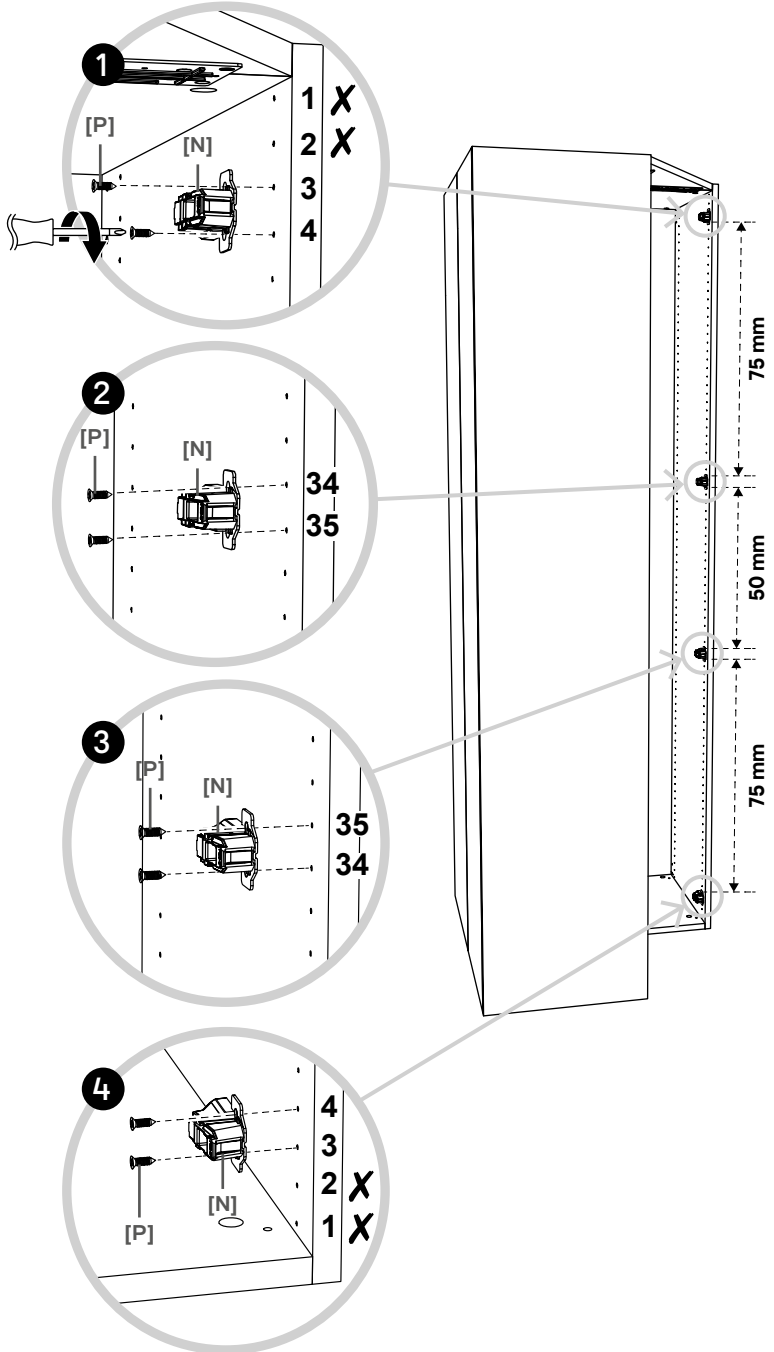



EN Assembly
PL Montaż
TR Montaj

FR Assemblage
RO Asamblare

27

26A

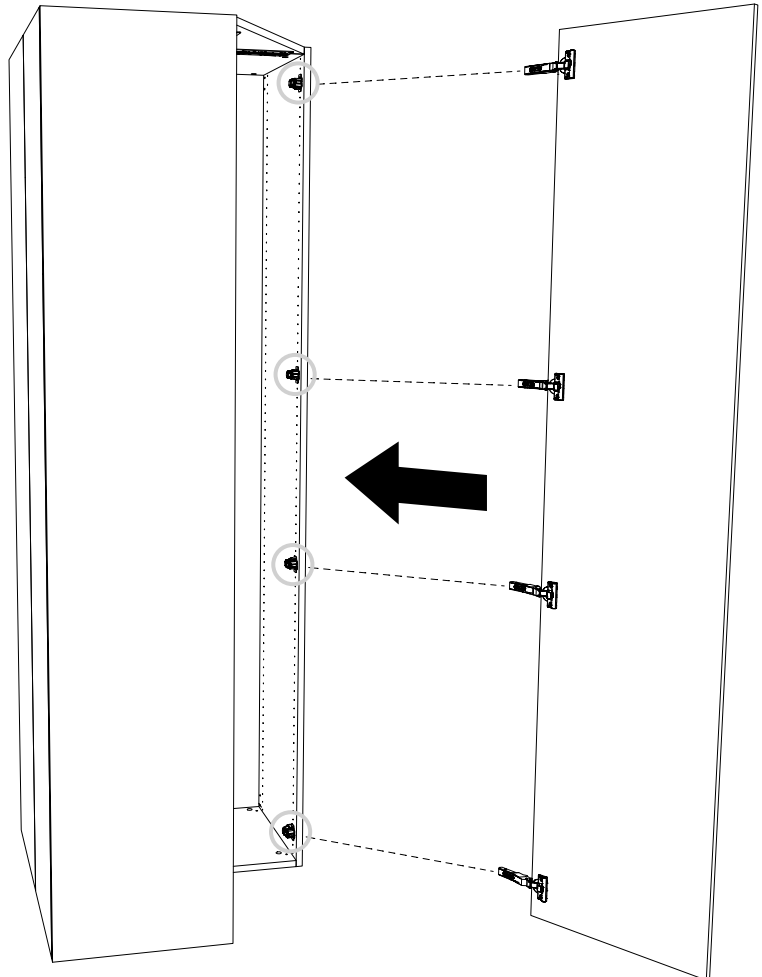
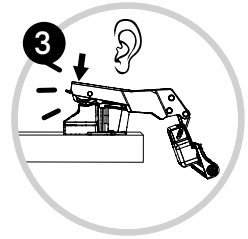
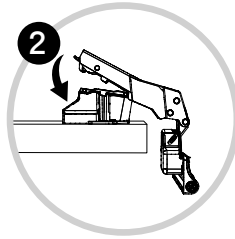
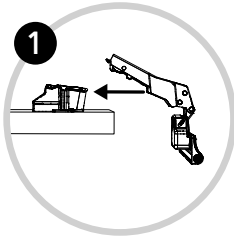



1B



[01] x 1

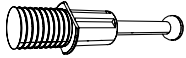

[A] x 4



[C] x 4

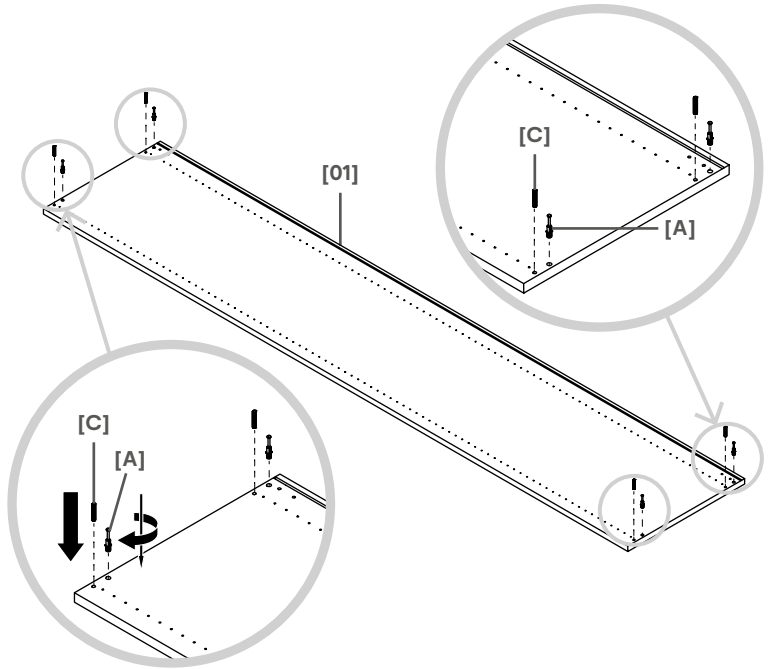

2B

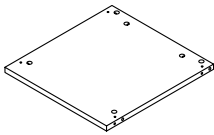

[02] x 1



[D] x 2



[K] x 1

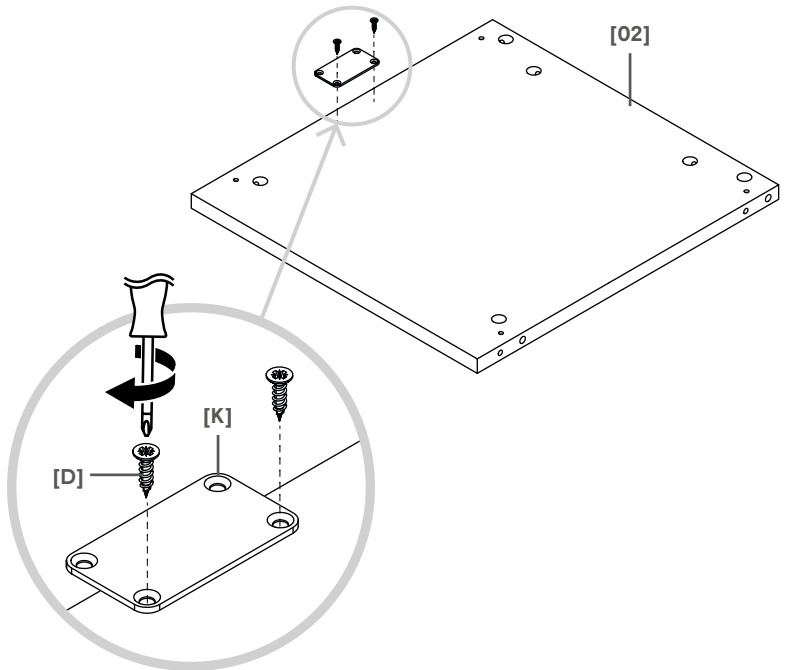



3B

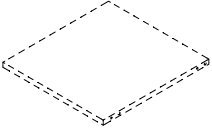

[03] x 1



[D] x 3

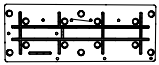

[M] x 1

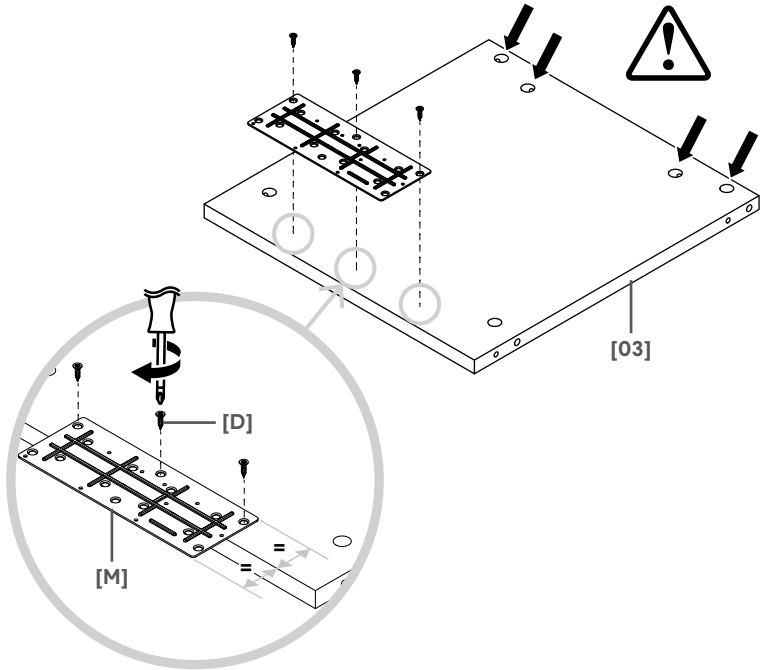

4B

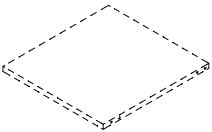

[03] x 1



[D] x 3

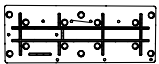

[M] x 1

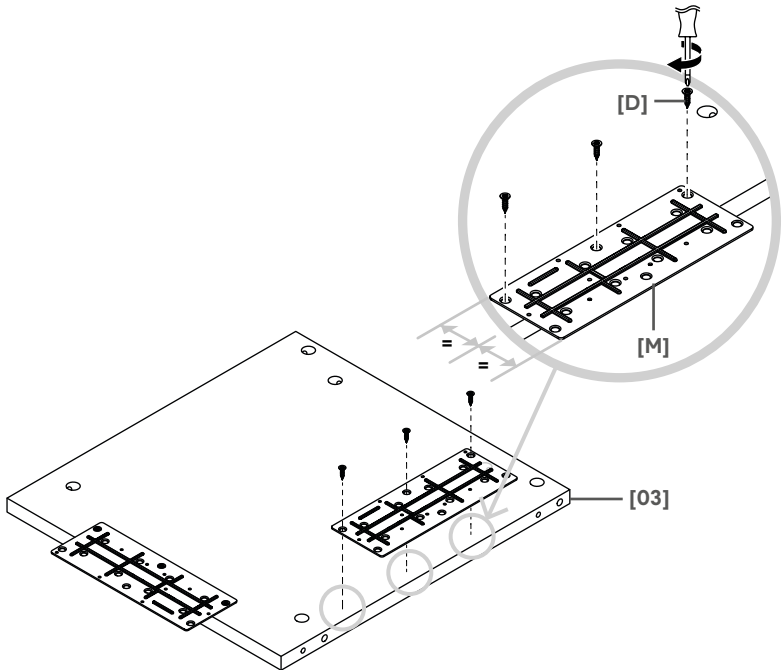



5B



[01] x 1

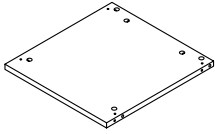

[02] x 1

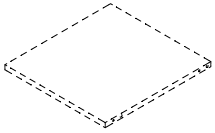

[03] x 1

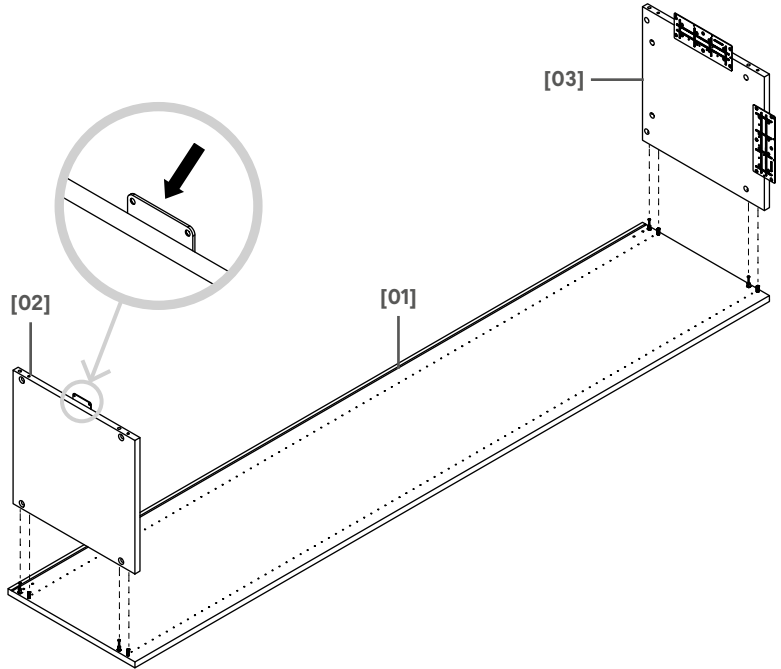

6B



[B] x 4

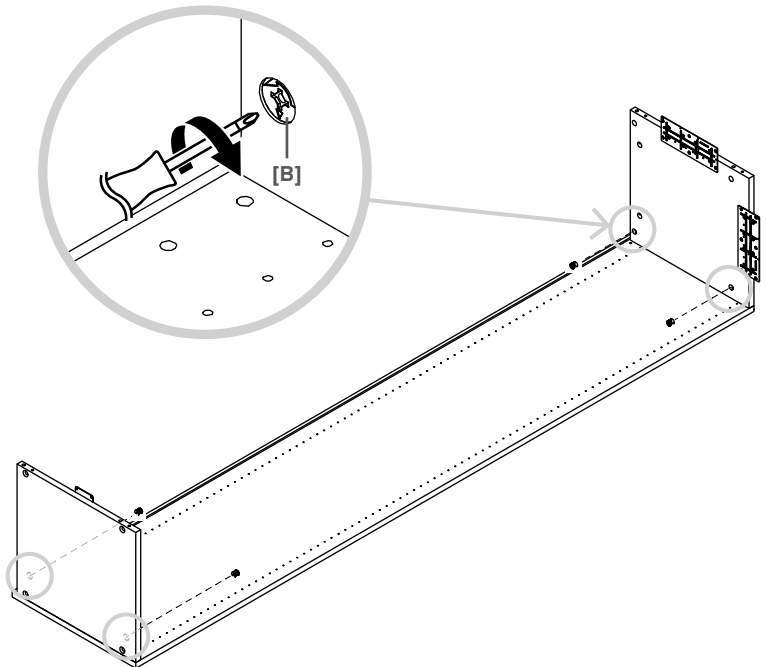



7B

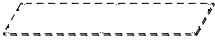

[04] x 1

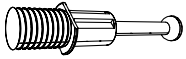

[A] x 4

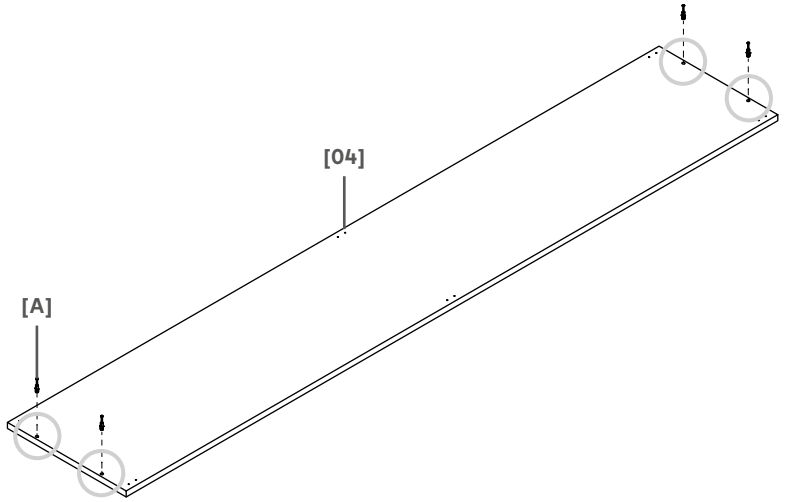

8B

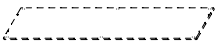

[04] x 1



[D] x 6



[K] x 3

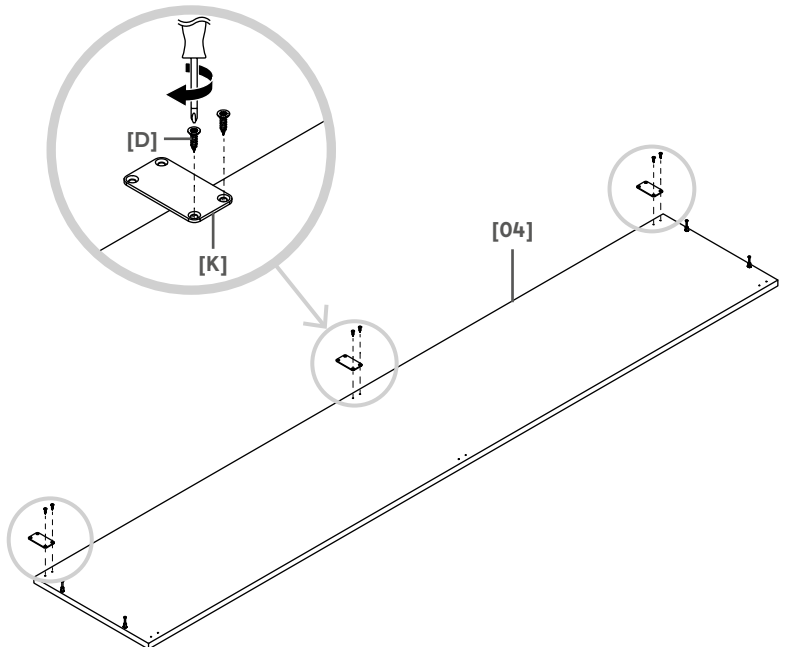



9B

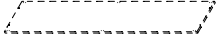

[04] x 1

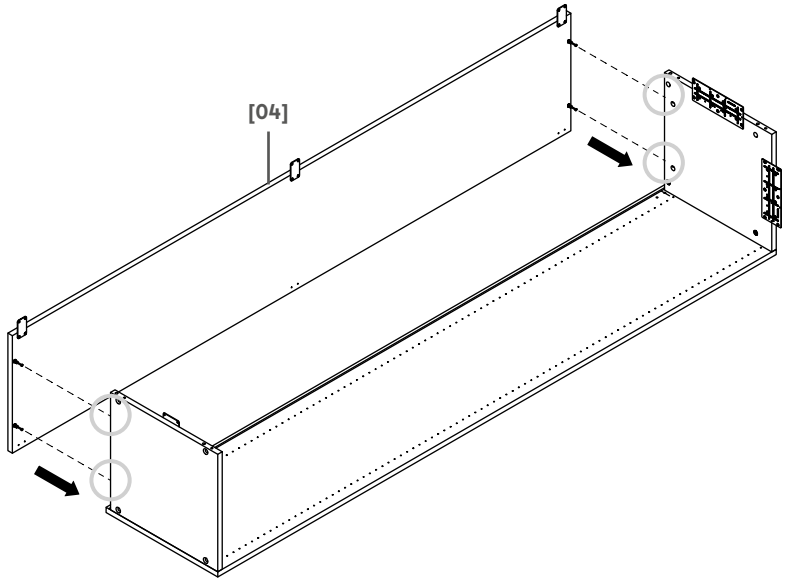

10B



[B] x 4

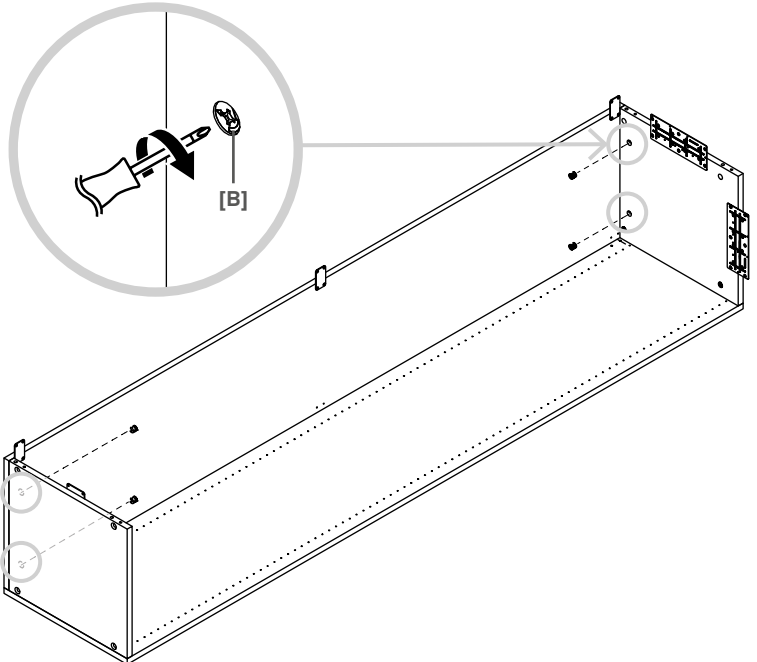



EN Assembly
PL Montaż
TR Montaj

FR Assemblage
RO Asamblare

11B



[D] x 6



[L] x 3

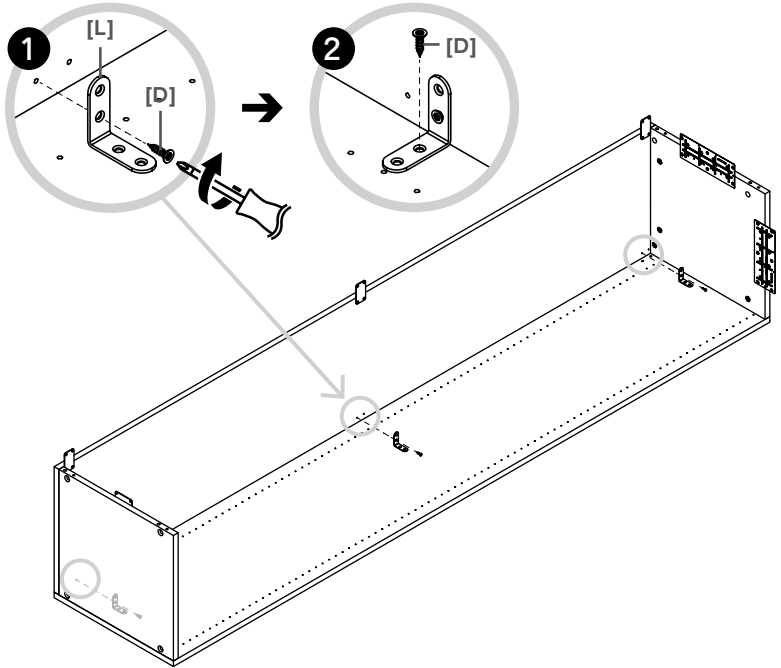

12B



[H] x 2



[I] x 2

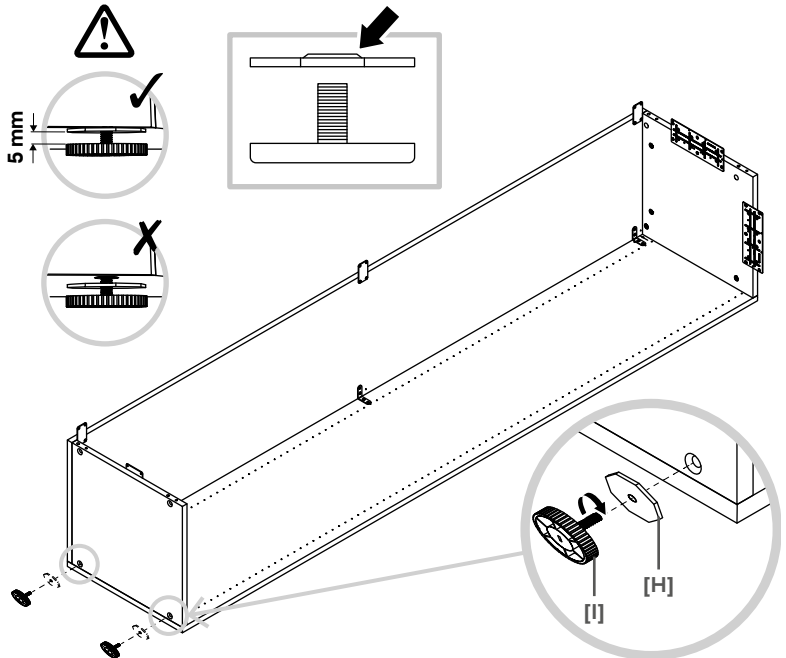



EN Assembly
PL Montaż
TR Montaj

FR Assemblage
RO Asamblare

34

13B

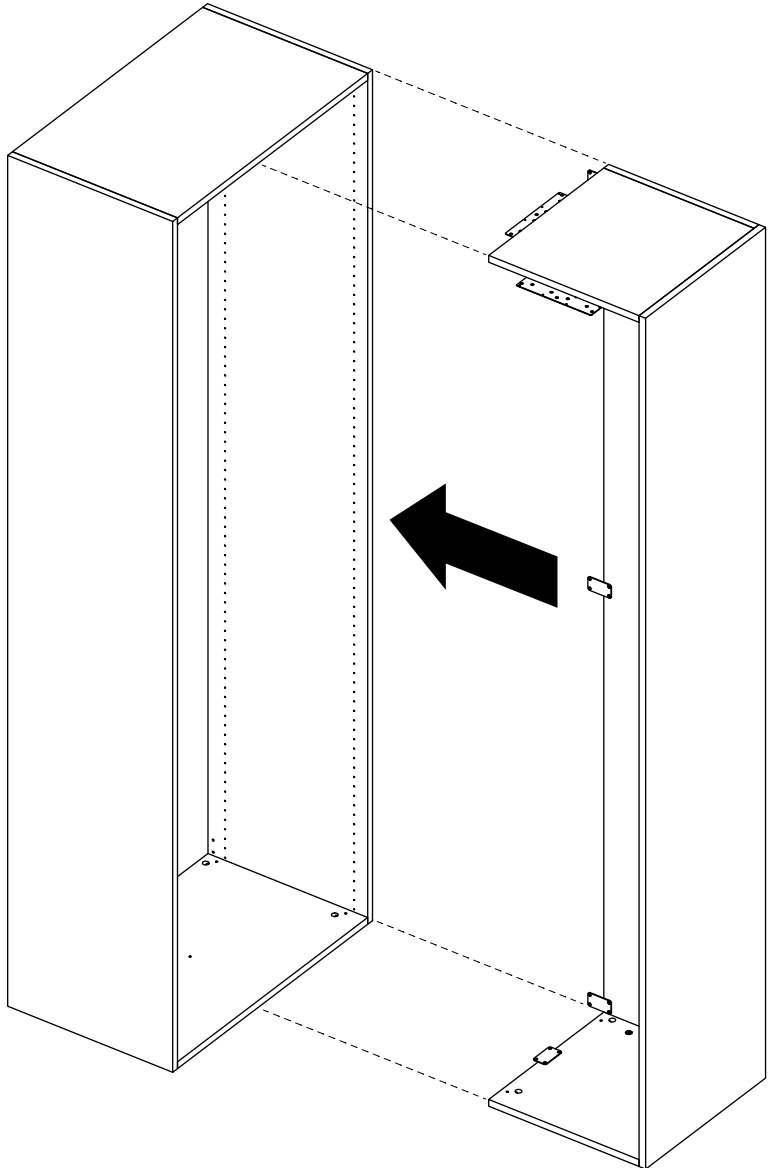



EN Assembly
PL Montaż
TR Montaj

FR Assemblage
RO Asamblare

35

14B



[D] x 8

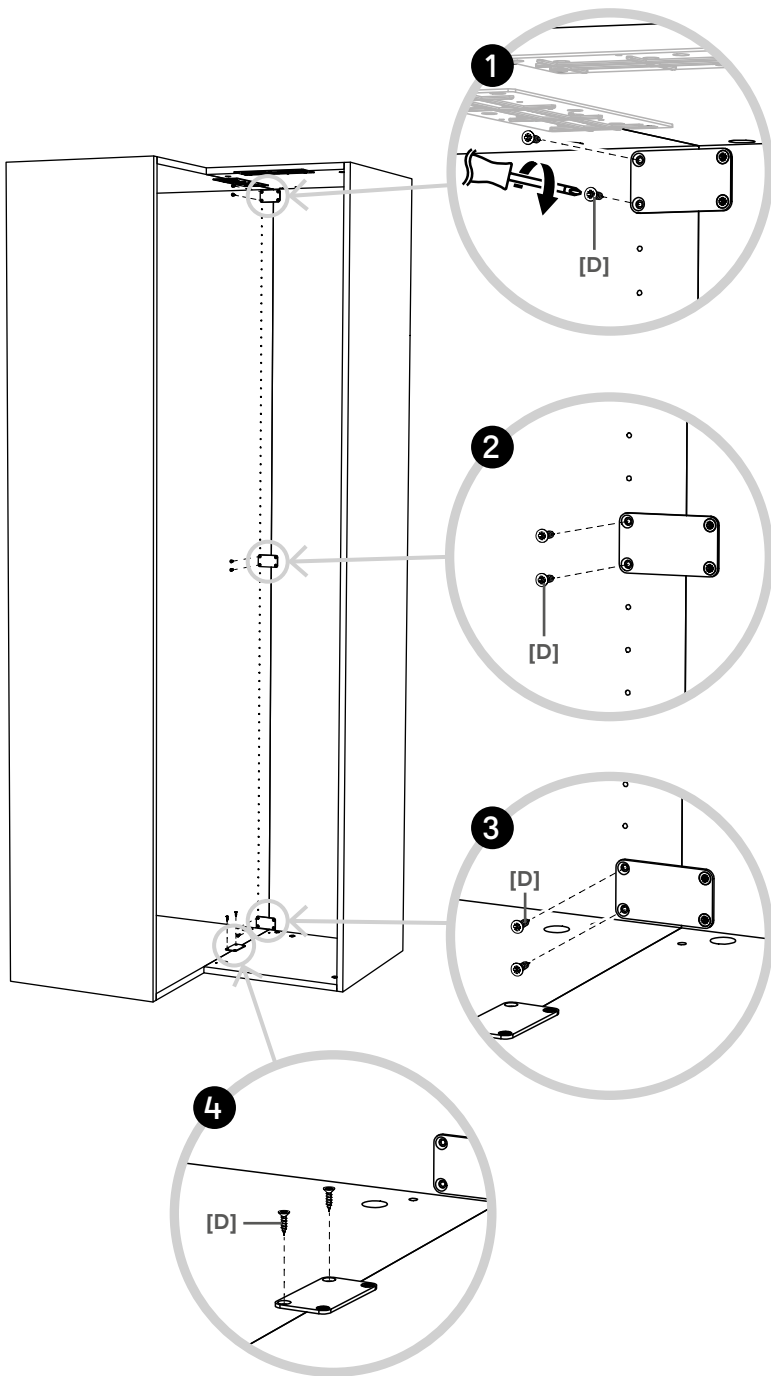



EN Assembly
PL Montaż
TR Montaj

FR Assemblage
RO Asamblare

15B

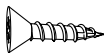

[D] x 3

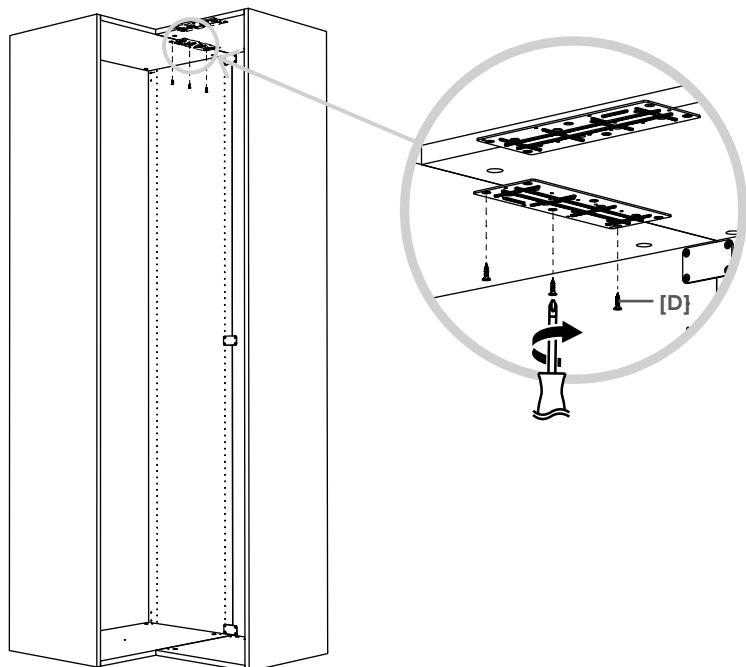

16B

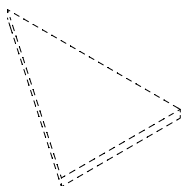

[O5] x 1

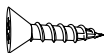

[D] x 3

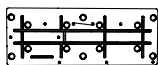

[M] x 1

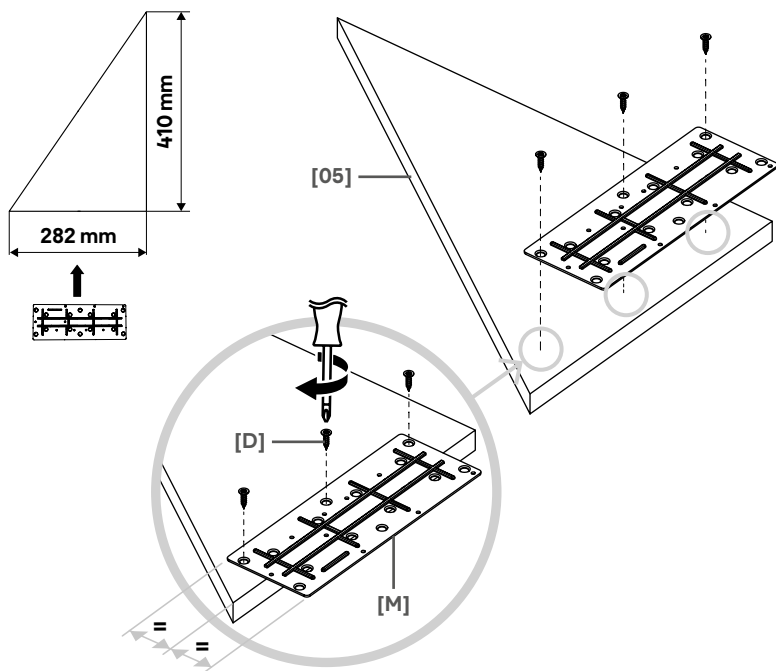



EN Assembly
PL Montaż
TR Montaj

FR Assemblage
RO Asamblare

37

17B

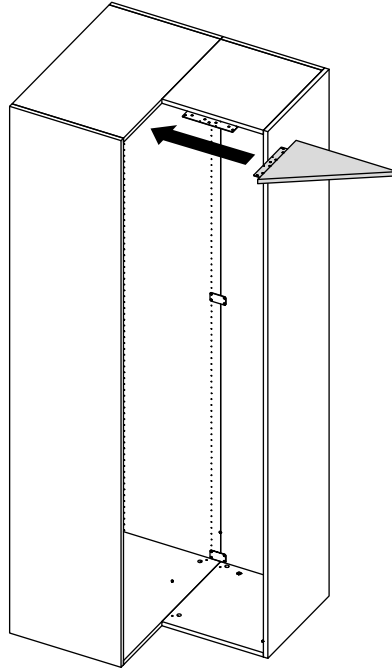

18B



[D] x 6

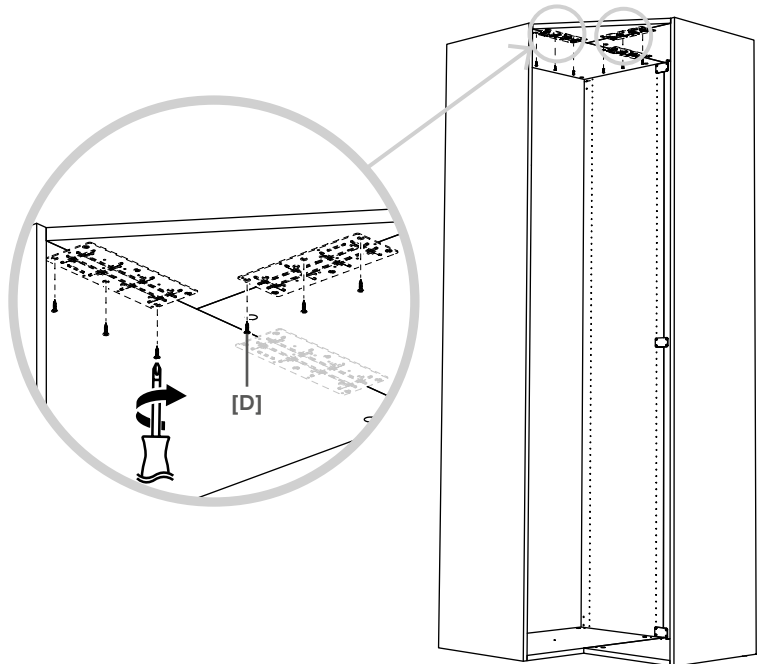



EN Assembly
PL Montaż
TR Montaj

FR Assemblage
RO Asamblare

19B



[J] x 1

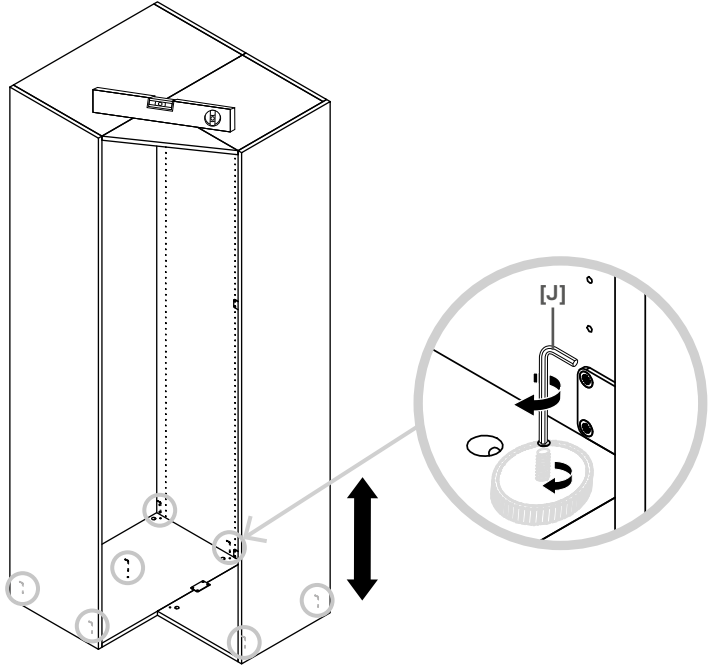

20B



[E] x 8

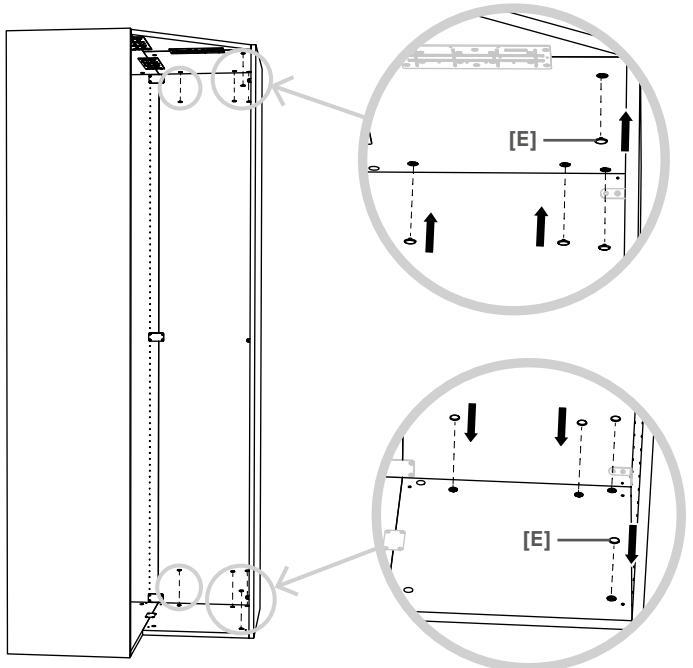



EN Assembly
PL Montaż
TR Montaj

FR Assemblage
RO Asamblare

21B



[F] x 4

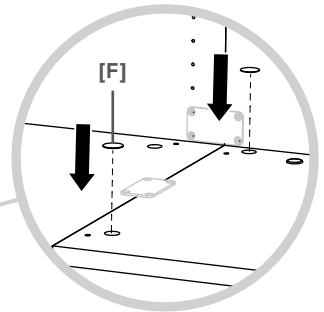
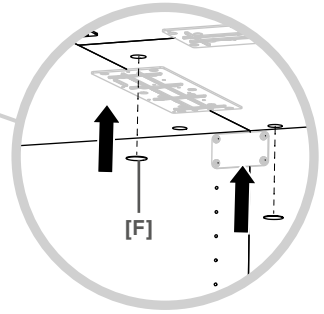
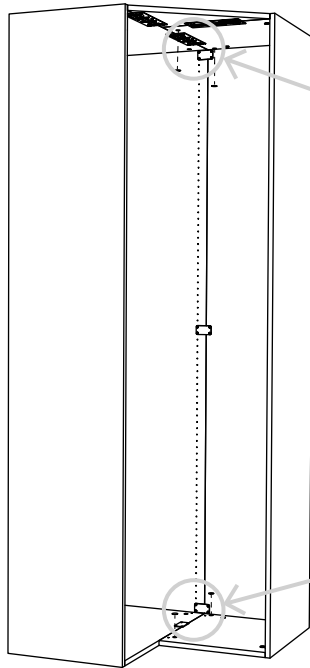

22B



[G] x 4

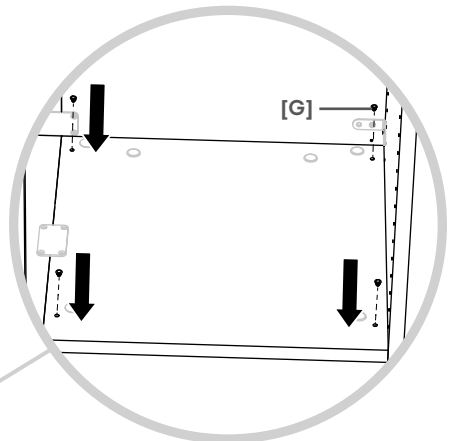
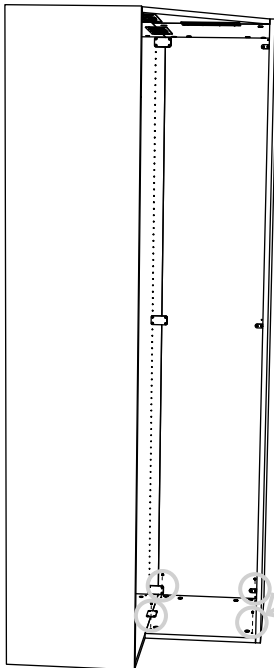



EN Assembly
PL Montaż
TR Montaj

FR Assemblage
RO Asamblare

40

23B

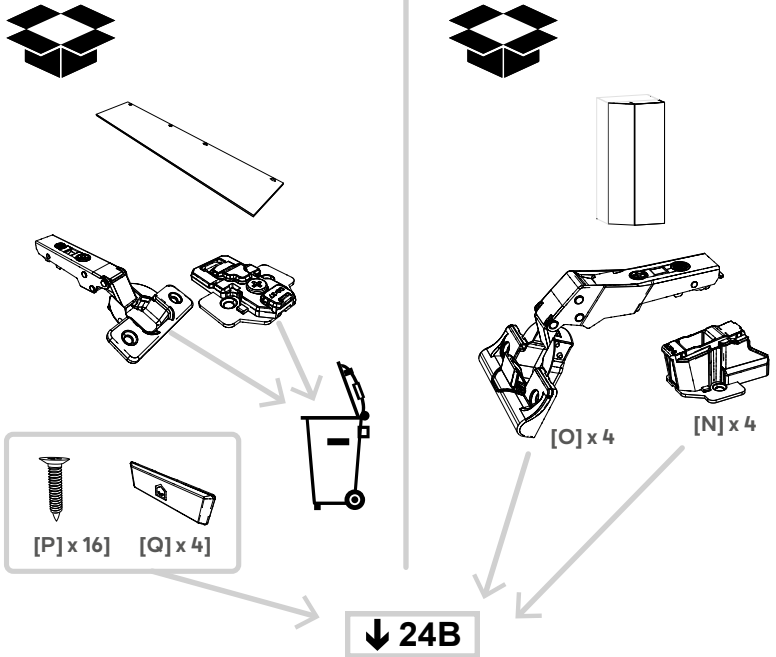

24B

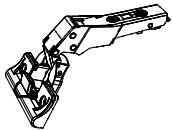
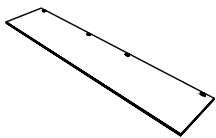

[O] x 4

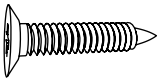

[P] x 8

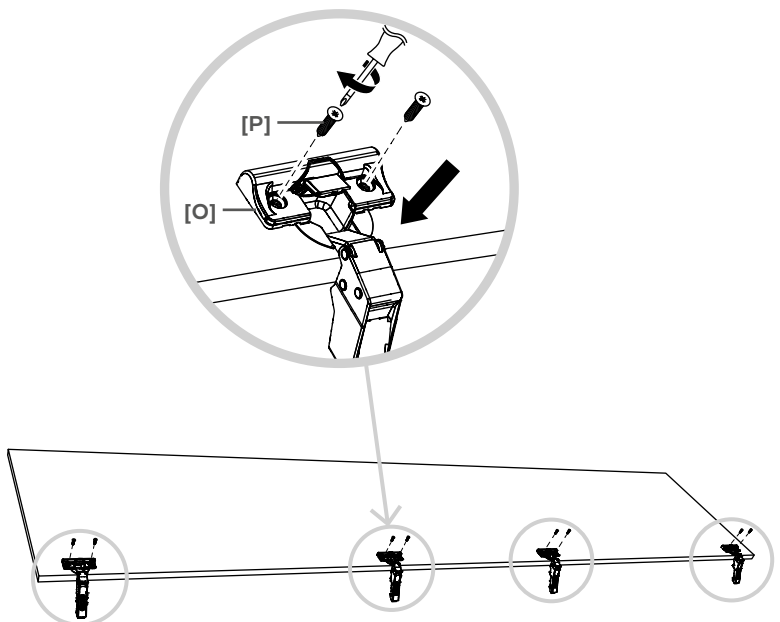



EN Assembly
PL Montaż
TR Montaj

FR Assemblage
RO Asamblare

25B



[N] x 4

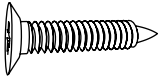

[P] x 8

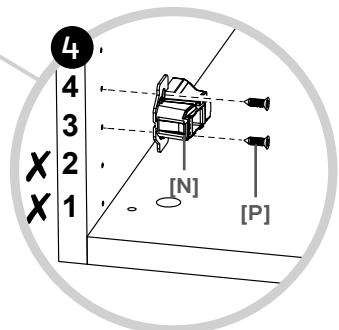
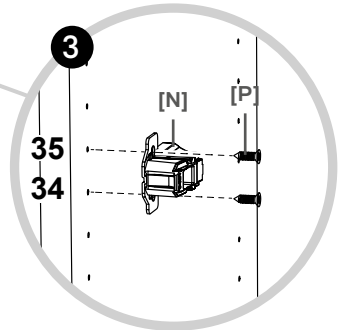
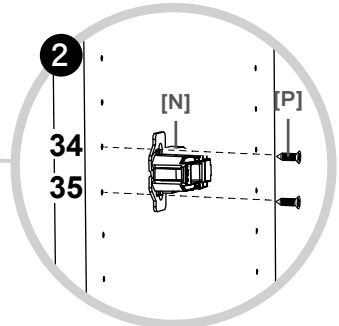
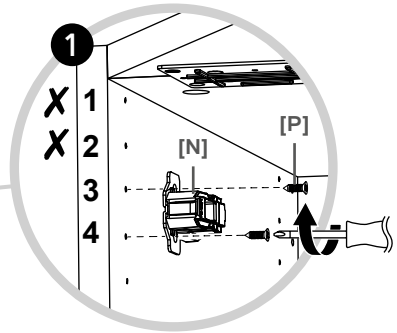
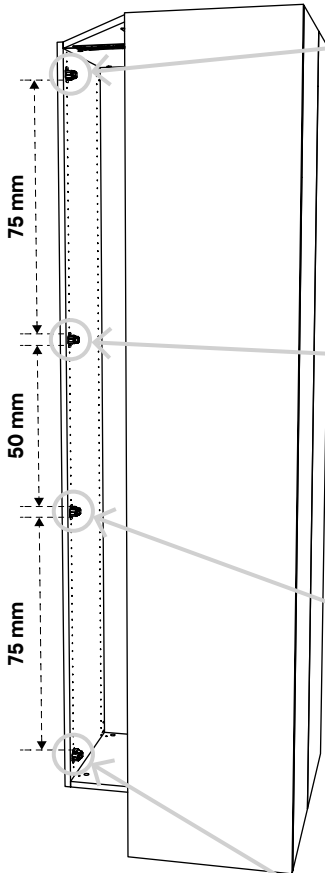



EN Assembly
PL Montaż
TR Montaj

FR Assemblage
RO Asamblare

42

26B

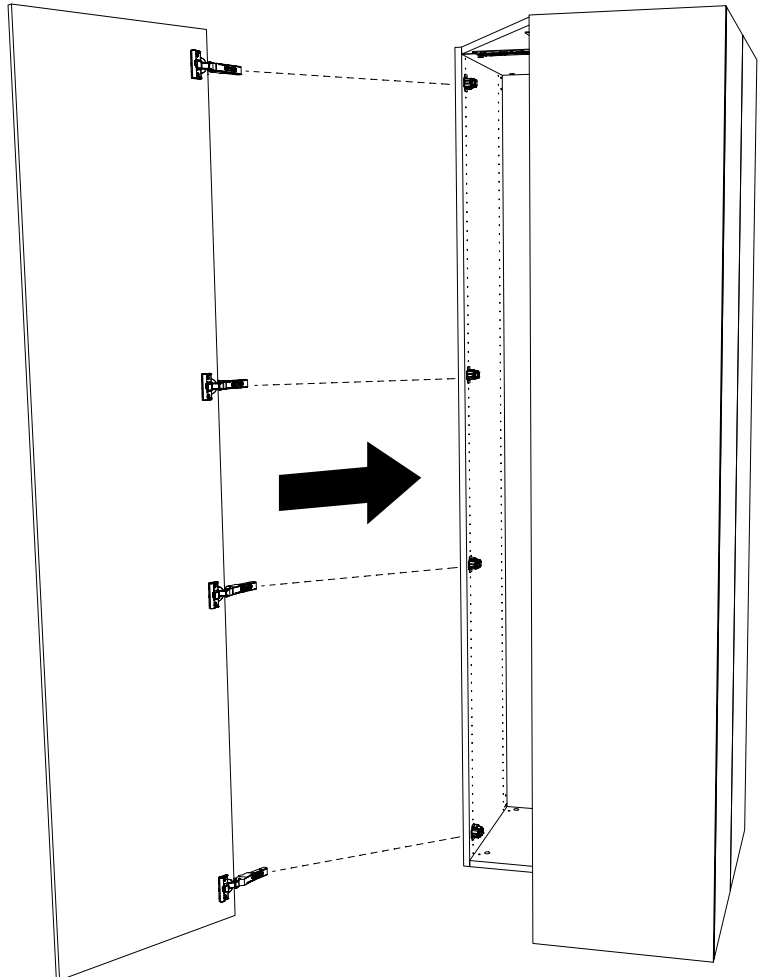
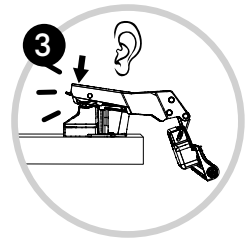
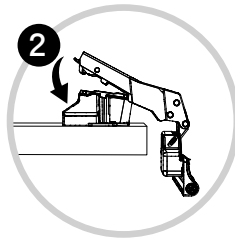
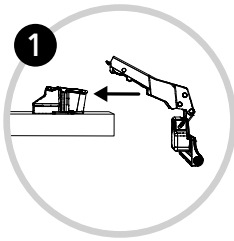



27

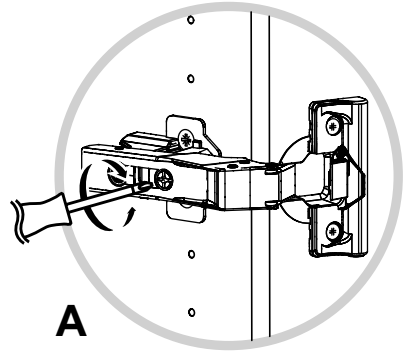
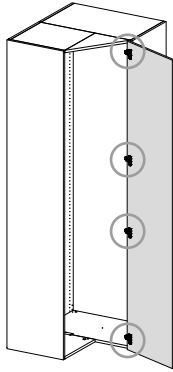

A

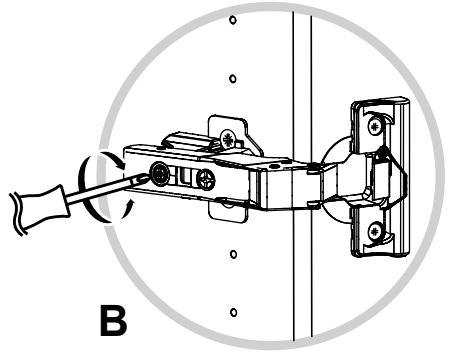
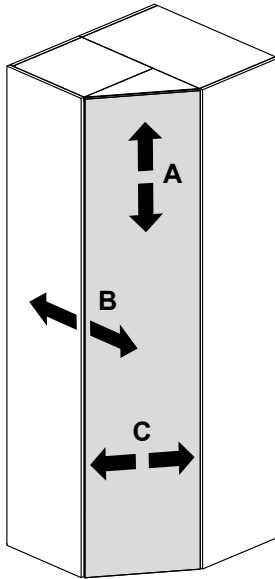

B

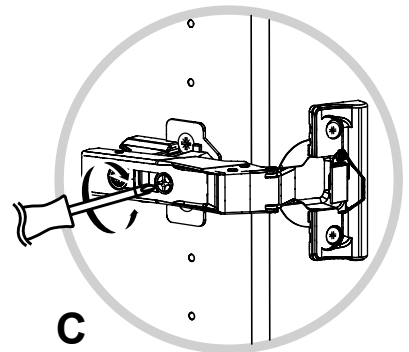

C



EN Assembly
PL Montaż
TR Montaj

FR Assemblage
RO Asamblare

28

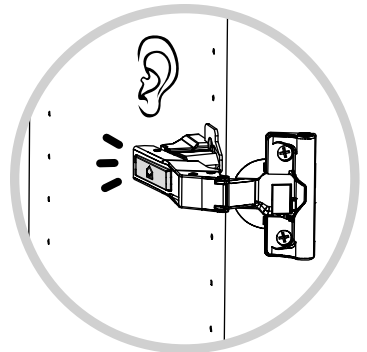
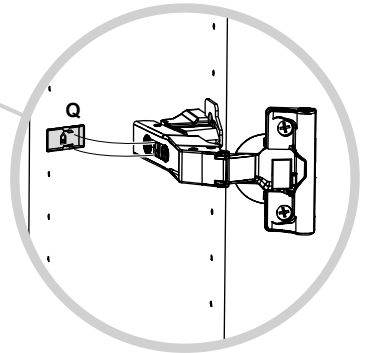
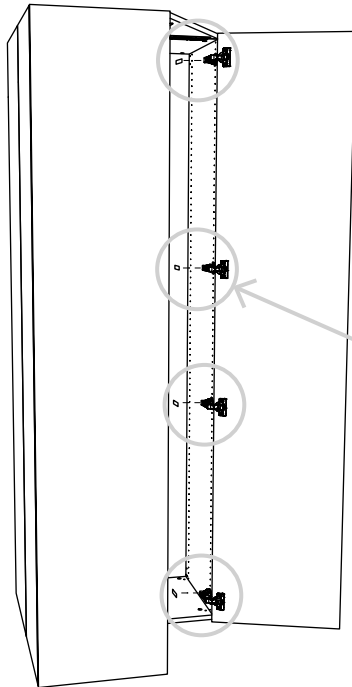

**Manufacturer • Fabricant • Producent •
Producător:**

UK Manufacturer:

Kingfisher International Products Limited,
1 Paddington Square, London, W2 1GG,
United Kingdom

EU Manufacturer:

Kingfisher International Products B.V.,
Rapenburgerstraat 175E,
1011 VM Amsterdam,
The Netherlands

EN www.diy.com

www.screwfix.com
www.screwfix.ie

**To view instruction manuals online,
visit www.kingfisher.com/products**

FR www.castorama.fr

www.bricodepot.fr
www.screwfix.fr

**Pour consulter les manuels d'instructions en
ligne, rendez-vous sur le site
www.kingfisher.com/products**

PL www.castorama.pl

**Aby zapoznać się z instrukcją obsługi online,
odwiedź stronę www.kingfisher.com/products**

RO www.bricodepot.ro

**Pentru a consulta manualele de instrucțiuni
online, vizitați www.kingfisher.com/products**

TR **İthalatçı Firma:**

KOÇTAŞ YAPI MARKETLERİ TİCARET A.Ş.
Sırrı Çelik Bulvarı Otokoç Blok No:9 Çekmeköy/
İstanbul 34788 Türkiye
Telefon: (90) 216 430 03 00
Faks: (90) 216 484 43 13
www.koctas.com.tr

**Kullanım kılavuzuna internet üzerinden ulaşmak
için www.kingfisher.com/products adresini
ziyaret edin**

Yetkili servis istasyonları ve yedek parça temini
için aşağıda yer alan Koçtaş Müşteri Hattı ve
Koçtaş GenelMüdürlük irtibat bilgilerinden
faydalanınız.

KOÇTAŞ MÜŞTERİ HİZMETLERİ

0850 209 50 50

AEEE Yönetmeliğine Uygundur

Menşei: Çin



**ÉLÉMENTS D'EMBALLAGE
À SÉPARER + NOTICE À
DÉPOSER DANS LE BAC
DE TRI**



FR
**Pensez à
donner ou recycler.**



Association

OU



Magasin

OU



Déchèterie