



HOW TO ASSEMBLE

MAJORCA™ 13x24 / 4x8

IMPORTANT!

Please read these instructions carefully before starting assembly.
Keep these instructions in a safe place for future reference.

www.canopia.com

A member of Palram Industries Ltd.

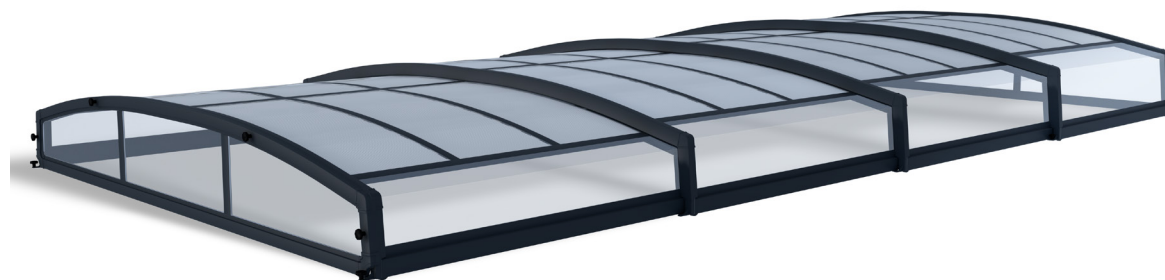

HAVE A CONCERN? WE CAN HELP.

Before returning your purchase:

Please take a look at our
"How to Assemble" video guide.
Scan the QR Code below or go to
canopia.shop/Assembly-Majorca

You didn't find what you
were looking for?
We can help at
canopia.shop/support

Still can't find what you
are looking for?
Please see next page for
local customer care.

HABEN SIE BEDENKEN? WIR KÖNNEN HELFEN.

Bevor Sie Ihren Kauf zurücksenden:

Schauen Sie sich bitte unsere
„Videoanleitung Zusammenbau“ an.
Scannen Sie den QR-Code unten
oder besuchen Sie
canopia.shop/Assembly-Majorca

Haben Sie nicht gefunden,
wonach Sie gesucht haben?
Unter canopia.shop/support
können wir helfen.

Sie haben noch nicht
gefunden wonach Sie suchen?
Auf der nächsten Seite
finden Sie den Kontakt zu
unserem lokalen Kundendienst.

TIENE ALGUNA INQUIETUD? PODEMOS AYUDARLE.

Antes de retornar su compra:

Por favor mire nuestro video de
montaje "How to Assemble".
Escanée el código QR abajo o
canopia.shop/Assembly-Majorca

No encontré lo que
estaba buscando?
Podemos ayudarle en
canopia.shop/support

Aún no encontré lo que buscaba?
Por favor vea en la siguiente
página el Servicio Local al Cliente.

UN SOUCI? UNE QUESTION? NOUS POUVONS VOUS AIDER.

Avant de renvoyer ce produit:

Jetez un coup d'oeil à notre
Vidéo d'Assemblage.
Scannez le code QR ci-dessous
ou rendez vous sur
canopia.shop/Assembly-Majorca

Vous n'avez pas trouvé
ce que vous cherchez ?
Nous pouvons vous aider sur
canopia.shop/support

Insatisfait/e ou sans réponse ?
Merci de contacter notre Service
Client local ci-dessous.





WE ARE HERE TO HELP

For general questions: canopia.com/contact-us

NORWAY • SWEDEN • ARGENTINA • GREECE • GREENLAND • ICELAND • ESTONIA • JAPAN • LATVIA • LITHUANIA
MAURITIUS • MEXICO • ROMANIA • RUSSIA • TURKEY • UZBEKISTAN • UKRAINE • SWAZILAND • KOREA

+972-4-848-6816 | customer.service@palram.com

USA	CANADA	HUNGARY • SLOVAKIA
877-627-8476 generalsupport@poly-tex.com	905-5646007 sales@footprintproducts.com	+420-493-523-523 servis@garland.cz
UNITED KINGDOM • IRELAND	GERMANY	NEW ZEALAND
01302-380775 customer.serviceUK@palram.com	0180-522-8778 customer.serviceDE@palram.com	0800 800 880 customer.service@palram.com
FRANCE • BELGIUM	ISRAEL	DENMARK
+33-169-791-094 customer.serviceFR@palram.com	04-848-6800 customer.service@palram.com	07-575 42 70 post@nshnordic.com
ITALY • NETHERLANDS • PORTUGAL • SPAIN	AUSTRIA • LUXEMBURG • LIECHTENSTEIN	SOUTH AFRICA
+33-169-791-094 customer.serviceFR@palram.com	+49-180-522-8778 customer.serviceDE@palram.com	011-397-7771 receptionza@palram.com
AUSTRALIA	AUSTRALIA - GREENHOUSES	CROATIA • SLOVENIA
03-9219-4444 salesvic@palram.com	03-9544-6-999 info@mazedistribution.com.au	0599-37-057 info@ms-viscom.com
CZECH REPUBLIC	SWITZERLAND	POLAND
0493-523-523 servis@garland.cz	062-287-33-77 info@ritter.ch	Infolinia: 801-011-929 22-349-93-36 kontakt@ogrodosfera.pl
CYPRUS	FINLAND	
0224-971-13 alpaco@alpacodomatica.com www.alpacodomatica.com	Neuvonta: 09-6866720 Tuki / Varaosat: 050-3715350 www.horizontenterprises.fi tuki@horizontenterprises.fi	

HAVE A CONCERN? WE CAN HELP.

Before returning your purchase:

Please take a look at our
"How to Assemble" video guide.
Scan the QR Code below or go to
canopia.shop/Assembly-Majorca

You didn't find what you
were looking for?
We can help at
canopia.shop/support

Still can't find what you
are looking for?
Please see next page for
local customer care.

HABEN SIE BEDENKEN? WIR KÖNNEN HELFEN.

Bevor Sie Ihren Kauf zurücksenden:

Schauen Sie sich bitte unsere
„Videoanleitung Zusammenbau“ an.
Scannen Sie den QR-Code unten
oder besuchen Sie
canopia.shop/Assembly-Majorca

Haben Sie nicht gefunden,
wonach Sie gesucht haben?
Unter canopia.shop/support
können wir helfen.

Sie haben noch nicht
gefunden wonach Sie suchen?
Auf der nächsten Seite
finden Sie den Kontakt zu
unserem lokalen Kundendienst.

TIENE ALGUNA INQUIETUD? PODEMOS AYUDARLE.

Antes de retornar su compra:

Por favor mire nuestro video de
montaje "How to Assemble".
Escanee el código QR abajo o
canopia.shop/Assembly-Majorca

No encontré lo que
estaba buscando?
Podemos ayudarle en
canopia.shop/support

Aún no encontré lo que buscaba?
Por favor vea en la siguiente
página el Servicio Local al Cliente.

UN SOUCI? UNE QUESTION? NOUS POUVONS VOUS AIDER.

Avant de renvoyer ce produit:

Jetez un coup d'oeil à notre
Vidéo d'Assemblage.
Scannez le code QR ci-dessous
ou rendez vous sur
canopia.shop/Assembly-Majorca

Vous n'avez pas trouvé
ce que vous cherchez ?
Nous pouvons vous aider sur
canopia.shop/support

Insatisfait/e ou sans réponse ?
Merci de contacter notre Service
Client local ci-dessous.



SAFETY ADVICE AND WARNINGS

- For safety purposes we strongly recommend the product to be assembled by at least 4 people.
- Some parts may have sharp edges. Please be careful when handling components.
- Do not leave sharp or blunt objects available for young children.
- Always wear gloves, eye protection, and long sleeves when assembling or performing any maintenance on your product.
- Do not attempt to assemble the product in windy or wet conditions.
- Do not attempt to assemble the product if you are tired, have taken drugs, medications or alcohol, or if you are prone to dizzy spells.
- Dispose of all plastic bags safely – keep them away from children’s reach.
- Keep children away from the assembly area.
- When using a stepladder or power tools, make sure that you are following the manufacturer’s safety advice.
- Do not allow anyone climb, stand or walk on the shelter.
- Do not hang or lay on the end product.
- Do not place heavy, sharp or protruding objects on the enclosure.
- Keep roof clear of snow, dirt & leaves.
- Heavy snow load on the roof can make it unsafe to stand below or nearby.
- In case of snow, fold your pool enclosure at the end of the pool.
- To comply with the tests carried out, the enclosure must be closed and lock when not in use.
- If color was scratched during assembly it can be fixed.
- In windy weather, the modules should not remain stored in the stacking position.
- The enclosure must be fixed to the ground in the closed position on the pool.
- This pool enclosure must be locked when not in use. A childproof lock is supplied by the company.
- This product should be solely used for pool covering.
- **Children near a swimming pool require your constant surveillance and must not be left alone.**
- **All access to the existing, for the leaned or attached covers, must be secured by the owner.**
- **The swimming pool may pose a danger to your children. Drowning has high potential to occur, if not paying special attention.**
- **Children near a swimming pool require your constant vigilance and your active supervision, even if they know how to swim.**
- **Learn lifesaving move.**
- **Safety is only ensured when the shelter, installed in accordance with the manufacturer’s/ distributor’s instructions is closed and locked.**
- **In the event of a malfunction which prevents the closure and the securing of the pool, or in the event of temporary unavailability of equipment, take all necessary precautions. Make sure to prevent access to the pool by young children until the shelter has been repaired.**
- **Keep and post first aid and local fire department numbers by the pool.**

CARE & MAINTENANCE

- In order to clean the product, use a mild detergent solution and rinse with cold clean water, using a soft cloth in order to prevent scratching.
- Do not use acetone, abrasive cleaners, or other special detergents to clean the panels.
- Clean the product once assembly is complete.

TOOLS & EQUIPMENT

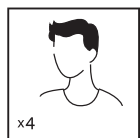

4 people needed



Microfiber Cloth

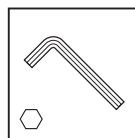

Allen Key / Hex Key
5 mm | 5/32"

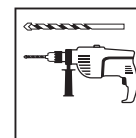

Electric Drill
With Drill Bit
12 mm | 15/32"

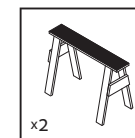

Trestle/ Saw horse



Wrench
13 mm | 1/2"

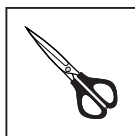

Scissors

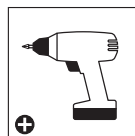

Cordless drill
Phillips head

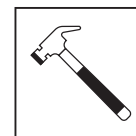

Hammer

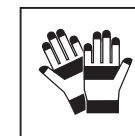

Work Gloves

BEFORE ASSEMBLY

- Choose your site carefully before beginning assembly.
- The ground surface must be perfectly flat and leveled and have a solid base such as concrete, asphalt, deck etc.
- Sort the parts and check against the content parts list.
- Parts should be laid out close at hand. Keep all small parts (screws etc.) in a bowl so they do not get lost.
- Please consult your local authorities if any permits are required prior to constructing the product.
- This product requires minimum of 0.5m surrounding the swimming pool.

IMPORTANT RECOMMENDATIONS AND GENERAL INFORMATION

- During assembly use a soft surface below the parts to avoid scratches and damages.
- It is imperative to change any damaged item or set of items as soon as possible.
- Use only parts supplied by Palram - Canopia.
- **Hardware:** stainless steel, aluminium and Nickel zinc coating screws.
- Internal angle brackets: stainless steel and aluminium.
- Aluminium structure.
- This product is painted based on QUALICOAT standard.
- Make sure the anchoring ground holes are clean with no dirt.
- Please read these instructions carefully before you start to assemble this product .
- Please carry out the steps in the order set out in these instructions.
- Keep these instructions in a safe place for future reference.
- **Please Note:** Anchoring this product to the ground is essential to its stability and rigidity. It is required to complete this stage in order for your warranty to be valid.
- Tighten all screws at the end of assembly.

DURING ASSEMBLY

- During assembly, you will encounter different icons for different products. Please see below for more information:



- During assembly you will encounter the information icon, please refer to the relevant assembly step for additional comments and assistance.



- You may use silicone lubricant spray on the frame in order to help you slide the panels into the profiles. Do not spray the Polycarbonate panels themselves.



- Use a rubber mallet if necessary.

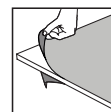

- Make sure you remove covering plastic film from both sides of the panel.

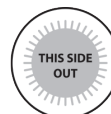

- All panels with the stamped words "THIS SIDE OUT" must be facing out to achieve full UV protection. Remove plastic sticker as panels are locked in place.

CONSEILS DE SECURITE ET AVERTISSEMENTS

- Pour des raisons de sécurité, nous recommandons vivement que le produit soit assemblé par au moins 4 personnes.
- Certaines pièces présentent des bords métalliques. Veuillez manipuler les composants avec précaution. Portez des gants, des chaussures et des lunettes de sécurité tout au long de l'assemblage.
- N'essayez pas d'assembler le produit en cas de vent ou de conditions humides.
- N'essayez pas d'assembler le produit si vous êtes fatigué, avez pris des médicaments ou consommé de l'alcool, ou si vous êtes enclin aux vertiges.
- Jetez précautionneusement tous les sacs plastiques – tenez-les hors de portée des enfants.
- Tenez les enfants à distance de la zone de montage.
- Si vous utilisez un escabeau ou des outils électriques, assurez-vous de respecter les consignes de sécurité du fabricant.
- Ne laissez personne marcher sur l'abri.
- Ne pas accrocher ni poser sur le produit final.
- Ne placez pas d'objets lourds, tranchants ou saillants sur l'abri.
- Éliminez la neige, la terre et les feuilles du toit et des gouttières.
- Une lourde charge de neige sur le toit peut rendre dangereux le fait de se tenir debout en dessous ou à proximité.
- Pour se conformer aux tests effectués, l'enceinte doit être fermée et verrouillée lorsqu'elle n'est pas utilisée.
- L'enceinte doit être fermée et verrouillée lorsqu'elle n'est pas utilisée.
- Si la couleur a été rayée pendant l'assemblage, elle peut être réparée.
- En cas de neige, pliez votre abri de piscine au bout de la piscine.
- Par temps venteux, les modules ne doivent pas rester stockés en position d'empilage.
- L'abri doit être fixé au sol en position fermée sur la piscine.
- Cet abri piscine doit absolument être verrouillé lorsqu'il n'est pas utilisé. Une sécurité enfant est fournie par entreprise.
- Ce produit ne peut pas remplacer la surveillance des parents sur les enfants.
- Ce produit ne doit être utilisé que pour les couvertures de piscine.
- Ne laissez pas d'objet coupant ou contondant à disposition des jeunes enfants
- **Les enfants près d'une piscine exigent votre surveillance constante et ne doivent pas être laissés seuls.**
- **Les accès de l'existant, pour les abris adossés ou accolés, doivent être sécurisés par le propriétaire.**
- **La piscine peut constituer un danger grave pour vos enfants. Une noyade est très vite arrivée. Des enfants près d'une piscine réclament votre constante vigilance et votre surveillance active, même s'ils savent nager.**
- **Apprenez les gestes qui sauvent.**
- **Attention la sécurité n'est assurée que lorsque l'abri, installé selon les instructions du fabricant/distributeur est fermé et verrouillé.**
- **Lors d'un constat de dysfonctionnement empêchant la fermeture et la sécurisation du bassin ou en cas d'indisponibilité temporaire de l'équipement, prendre toutes les mesures afin d'empêcher de l'accès du bassin aux jeunes enfants et ce, jusqu'à la réparation de l'abri.**
- **mémoriser et afficher près de la piscine les numéros de premiers secours :**
 - pompiers : (18 pour la France ou 112 depuis un téléphone portable) ;
 - SAMU : (15 pour la France) ;
 - Centre antipoison

ENTRETIEN & MAINTENANCE

- Pour nettoyer votre produit, utilisez un chiffon doux et rincez à l'eau claire et froide.
- N'utilisez pas d'acétone, de nettoyants abrasifs, ou autres détergents spéciaux pour nettoyer les panneaux.
- Nettoyez le produit une fois le montage terminé.

OUTILS ET ÉQUIPEMENT

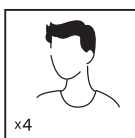

x4

- Nécessite 4 personnes



- Chiffon microfibre

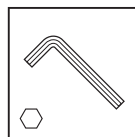

- Clé Allen 5 mm | 5/32"

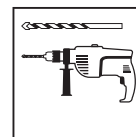

- Perceuse filaire avec foret 12 mm | 15/32"

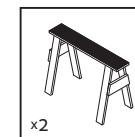

x2

- Tréteaux

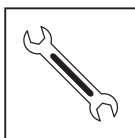

- Clé 13 mm | 1/2"



- Ciseaux

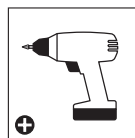

- Perceuse - Tête Phillips



- Marteau



- Gants de travail

AVANT L'ASSEMBLAGE

- Choisissez votre site avec soin avant de commencer l'assemblage.
- La surface du sol doit être parfaitement plate et nivelée et avoir une base solide telle que comme le béton, l'asphalte, le pont, etc.
- Ordonnez les pièces et vérifiez-les avec la liste des pièces contenues.
- Les pièces doivent être disposées à portée de main. Rangez toutes les petites pièces (vis, etc.) dans un bol pour ne pas les égarer.
- Veuillez consulter les autorités locales au cas où des permis sont nécessaires pour la construction du produit.
- Ce produit nécessite un minimum de 0,5 m autour de la piscine.

RECOMMANDATIONS IMPORTANTES
ET INFORMATIONS GÉNÉRALES

- Pendant le montage, placez une surface souple sous les pièces pour éviter de les érafler ou de les endommager.
- Il est impératif de changer tout article ou ensemble d'articles endommagé dès que possible.
- N'utilisez que des pièces fournies par Palram - Canopia.
- Quincaillerie: vis de revêtement en acier inoxydable, aluminium et nickel zinc.
- Équerres internes: acier inoxydable et aluminium.
- Structure en aluminium.
- Ce produit est peint sur la base de la norme QUALICOAT.
- Assurez-vous que les trous d'ancrage au sol sont propres et sans saleté.
- Veuillez lire attentivement ces instructions avant de débiter le montage du produit.
- Veuillez suivre les étapes dans l'ordre indiqué dans ces instructions.
- Conservez ces instructions en lieu sûr pour référence ultérieure.
- **Veuillez noter :** Cette étape d'ancrage du produit au sol est essentielle à sa stabilité et à sa rigidité, e est de plus nécessaire pour assurer la validité de votre garantie.
- Serrez toutes les vis à la fin de l'assemblage.

DURANT L'ASSEMBLAGE

- Lors du montage, vous trouverez différentes icônes correspondant à différents produits. Pour de plus amples informations, veuillez vous référer à ce qui suit:



- Pendant le montage, vous verrez l'icône d'information, veuillez-vous référer à la phase de montage correspondante pour des commentaires et une assistance supplémentaires.



- Vous pouvez utiliser un spray de lubrifiant pour silicone afin de vous aider à glisser les panneaux dans les profilés. Ne pulvériser pas les panneaux.



- Utilisez un maillet en caoutchouc si nécessaire.

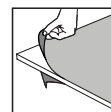

- Assurez-vous de retirer le film plastique couvrant des deux côtés du panneau.

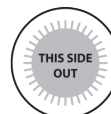

- Tous les panneaux estampillés "THIS SIDE OUT" doivent être orientés vers l'extérieur pour assurer une protection UV intégrale. Retirez les stickers en plastique quand les panneaux sont verrouillés et bien en place.

PFLEGE- UND SICHERHEITSHINWEISE

- Aus Sicherheitsgründen empfehlen wir, das Produkt nicht alleine zusammenzubauen.
- Einige Teile besitzen Kanten aus Metall. Seien Sie vorsichtig, wenn Sie diese Teile zusammenbauen. Tragen Sie während des Aufbaus immer Handschuhe, Schuhe und Schutzbrillen.
- Bitte folgen Sie den in diesem Handbuch aufgeführten Anweisungen.
- Lassen Sie keine scharfen oder stumpfen Gegenstände für kleine Kinder erreichbar.
- Sortieren Sie die Teile und überprüfen Sie Sie gegen den Inhalt der Liste.
- Aus Sicherheitsgründen empfehlen wir, das Produkt nicht alleine zusammenzubauen.
- Versuchen Sie nicht, den das Produkt bei windigen oder feuchten Wetterverhältnissen zusammenzubauen.
- Entsorgen Sie die Plastikbeutel vorschriftsgemäss – und achten Sie darauf, dass sie nicht in Reichweite von Kindern kommen.
- Halten Sie das Dach frei von Schnee, Dreck und Blättern.
- Versuchen Sie nicht, den das Produkt aufzubauen, wenn Sie müde sind, Drogen, Medikamente oder Alkohol zu sich genommen haben oder zu Schwindelanfällen neigen.
- Wenn die Farbe während der Montage zerkratzt wurde, kann sie fixiert werden.
- Wenn Sie eine Stufenleiter oder Elektrowerkzeuge benutzen, achten Sie darauf, die Sicherheitshinweise des Herstellers zu befolgen.
- Erlauben Sie niemandem, auf die Verdeckung zu klettern, oder darauf zu stehen oder zu gehen.
- Grosse Mengen von Schnee auf dem Dach können den produkt beschädigen und dazu führen, dass es nicht mehr sicher ist, unter oder neben ihm zu stehen.
- Damit die durchgeführten Tests zu erfüllt werden, muss das Gehäuse geschlossen und verriegelt sein, wenn es nicht verwendet wird.
- Das Gehäuse muss geschlossen und verriegelt sein, wenn es nicht verwendet wird.
- Bei Schnee klappen Sie Ihre Poolüberdachung am Ende des Pools zusammen.
- Bei windigem Wetter sollten die Module nicht gestapelt aufbewahrt werden.
- Die Schutzüberdachung muss am Boden befestigt werden, der Pool muss währenddessen geschlossen sein.
- Diese Poolüberdachung muss verschlossen sein, wenn sie nicht verwendet wird. Ein kindersicheres Schloss wird von der Firma mitgeliefert.
- Dieses Produkt kann die Überwachung der Kinder seitens der Eltern nicht ersetzen.
- Dieses Produkt sollte ausschließlich zur Poolabdeckung verwendet werden.
- **Kinder in der Nähe eines Swimmingpools bedürfen ständiger Überwachung und dürfen nicht allein gelassen werden.**
- **Jeder Zugang zu den vorhandenen, für die angelehnten oder befestigten Abdeckungen, muss vom Eigentümer gesichert werden.**
- **Das Schwimmbecken kann eine Gefahr für Ihre Kinder darstellen. Das Risiko des Ertrinkens ist hoch, wenn auf die Kinder nicht geachtet wird.**
- **Kinder, die sich in der Nähe eines Schwimmbeckens aufhalten, benötigen Ihre ständige Wachsamkeit und aktive Aufsicht, selbst wenn sie schwimmen können.**
- **LEBENSRETTENDE BEWEGUNG LERNEN.**
- **DIE SICHERHEIT IST NUR GEWÄHRLEISTET, WENN DIE ABDECKUNG, GEMÄSS DEN ANWEISUNGEN DES.**
- **Herstellers/Händlers installiert wurde, geschlossen und verriegelt ist.**
- **Im Falle einer Funktionsstörung, die das Schließen und Sichern des Schwimmbeckens verhindert, oder bei vorübergehender Nichtverfügbarkeit dieser Ausrüstung, sind alle erforderlichen Sicherheitsvorkehrungen zu treffen. Stellen Sie sicher, dass der Zugang von Kleinkindern zum Schwimmbecken, bis repariert verhindert wird.**
- **Bewahren Sie die Nummern für Erste Hilfe und die örtliche Feuerwehr am Schwimmbecken auf.**
- **Hinweis: Der Schnee muss von den Dachstrukturen entfernt werden, wenn die angesammelte Schneehöhe 40 cm (1'4") überschreitet.**

PFLEGE & WARTUNG

- Säubern Sie das Produkt nach dem Aufbau.
- Wenn Ihr Produkt gereinigt werden muss, verwenden Sie ein weiches Tuch und spülen Sie es mit kaltem, klarem Wasser ab.
- Verwenden Sie für die Reinigung der Paneele kein Azeton, keine Scheuermittel oder andere spezielle Reinigungsmittel.

WERKZEUGE & AUSTRÜSTUNG



4 Personen erforderlich



Mikrofaser Tuch

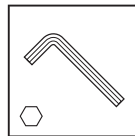

Inbusschlüssel / Sechskantschlüssel 5 mm | 5/32"

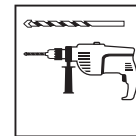

Bohrmaschine mit Bohrer 12 mm | 15/32"

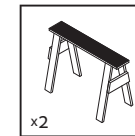

Bock/ Sägebock



Schraubenschlüssel 13 mm | 1/2"

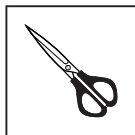

Schere

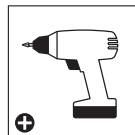

Akkubohrer - Kreuzschlitzaufsatz

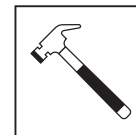

Hammer

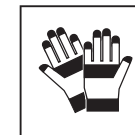

Arbeitshandschuhe

VOR DEM ZUSAMMENBAU

- Wählen Sie Ihren Standort sorgfältig, bevor Sie mit dem Aufbau beginnen.
- Der Untergrund muss vollkommen flach und eben sein und einen festen Untergrund haben, wie Beton, Asphalt, Fliesen etc.
- Sortieren Sie die Teile und prüfen, ob alle Teile, die auf der Inhaltsliste stehen erhalten sind. Die Teile sollten in Ihrer unmittelbarer Nähe liegen.
- Bewahren Sie alle Kleinteile (Schrauben etc.) in einer Schüssel auf damit sie nicht verloren gehen.
- **Hinweis:** Verwenden Sie nur die in der Inhaltsliste angeführten Teile, es können eventuell überschüssige Teile finden.
- Bitte wenden Sie sich an Ihre Kommunalbehörde, falls der Aufbau des the product eine Genehmigung benötigen sollte.
- Dieses Produkt benötigt ein Bereich von mindestens 0,5 m um den Pool herum.

WICHTIGE HINWEISE UND ALLGEMEINE INFORMATION

- Es ist unbedingt erforderlich, beschädigte Teile so schnell wie möglich auszuwechseln
- Verwenden Sie nur von Palram - Canopia gelieferte Teile.
- **Hardware:** Edelstahl, Aluminium und Nickel-Zink beschichtete Schrauben.
- Innenwinkel: Edelstahl und Aluminium.
- Aluminiumstruktur.
- Die Lackierung dieses Produkt basiert auf dem QUALICOAT-Standard.
- Stellen Sie sicher, dass die Löcher für die Verankerung sauber und schmutzfrei sind.
- Bitte lesen Sie diese Anleitung aufmerksam durch, bevor Sie mit der Montage dieses Produktes beginnen.
- Bitte führen Sie die einzelnen Schritte in der in dieser Anleitung angegebenen Reihenfolge durch.
- Bewahren Sie diese Anleitung für späteren Gebrauch sicher auf.
- **Bitte beachten:** Die Verankerung dieses Produkts im Untergrund ist wesentlich für seine Stabilität und Festigkeit. Sie ist unablässlich, um diesen Arbeitsschritt zu beenden, damit Ihre Garantie gültig bleibt.
- Ziehen Sie alle Schrauben nach dem Abschluss der Montage an.

WÄHREND DER MONTAGE

- Während der Montage werden Sie verschiedene Symbole für unterschiedliche Produkte sehen. Weitere Informationen finden Sie unten:



- Während der Montage begegnet Ihnen das Informationssymbol, weitere Hinweise und Hilfestellungen finden Sie auf der Seite "WICHTIGE MONTAGESCHRITTE".



- Sie können Silikonschmierspray auf den Rahmen sprühen, um das Einschieben der Platten in die Profile zu erleichtern. Besprühen Sie nicht die Platten.



- Nehmen Sie – falls nötig – einen Gummihammer zur Hilfe.

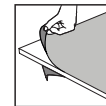

- Sie die abdeckende Kunststoffolie von beiden Seiten der Verkleidung entfernen.



- Alle mit den Worten "THIS SIDE OUT" versehenen Platten müssen nach außen zeigen, um den vollen UV-Schutz zu gewährleisten. Entfernen Sie die Aufkleber, sobald die Platten montiert sind.

CONSEJOS DE SEGURIDAD Y ADVERTENCIAS

- Por razones de seguridad, recomendamos encarecidamente que el producto sea ensamblado por al menos 4 personas.
- Algunas piezas pueden tener bordes afilados. Tenga cuidado al manipularlas.
- No deje objetos contundentes o afilados al alcance de los niños pequeños.
- Utilice siempre guantes, protección para los ojos y mangas largas cuando ensamble o realice cualquier tipo de mantenimiento en su producto.
- No intente montar el invernadero en días de viento o días con humedad.
- No intente montar este producto si usted está cansado, ha tomado drogas o alcohol o si usted es propenso a ataques de mareo.
- Disponga todas las bolsas plásticas en lugar seguro - guárdelas fuera del alcance de niños.
- Mantenga a los niños fuera del área de montaje.
- Al usar una escalera plegable o herramientas eléctricas asegúrese de que sigue las instrucciones de seguridad de los fabricantes.
- No permita que nadie se suba, se pare o camine sobre la cubierta telescópica.
- No se cuelgue ni se acueste sobre la cubierta telescópica.
- No coloque objetos pesados, afilados o que sobresalgan en la cubierta.
- Mantenga el techo de la cubierta libre de nieve, suciedad y hojas.
- Una alta carga de nieve en el techo de la cubierta puede hacer que no sea seguro permanecer debajo o cerca.
- En caso de nevada, pliegue la cubierta de la piscina al final de la misma.
- Para cumplir con las pruebas realizadas, la carcasa debe estar cerrada y bloqueada cuando no se utilice.
- Si la capa de pintura se rayó durante la instalación, se puede reparar.
- En caso de viento, los módulos no deben almacenarse en posición de apilado.
- La cubierta debe estar fijada al suelo cuando esté cerrada sobre la piscina.
- Esta cubierta de piscina debe estar cerrada con llave cuando no se utilice. La empresa suministra un candado a prueba de niños.
- Este producto sólo debe utilizarse para cubrir piscinas.
- **Los niños que estén cerca de una piscina deben estar supervisados en todo momento y no deben quedarse solos.**
- **Cualquier acceso a las cubiertas, entreabiertas o adosadas, debe ser asegurado por el propietario.**
- **La piscina puede suponer un peligro para sus hijos. El peligro de ahogarse es grande si no se tiene especial cuidado.**
- **Los niños que están cerca de una piscina requieren su vigilancia constante y su supervisión activa, incluso si saben nadar.**
- **Aprenda primeros auxilios, para mayor seguridad.**
- **La seguridad sólo está garantizada si la cubierta, instalada de acuerdo con las instrucciones del fabricante/distribuidor, está cerrada con llave.**
- **En caso de una avería que impida cerrar y asegurar la piscina, o en caso de que la cubierta no este disponible de forma temporal, tome todas las precauciones necesarias. Asegúrese de impedir el acceso de los niños pequeños a la piscina hasta que la cubierta telescópica haya sido reparada.**
- **Mantenga y coloque junto a la piscina los números de emergencias y de los bomberos locales.**

CUIDADOS & MANTENIMIENTO

- Para limpiar el producto, use un trapo suave y enjuague con agua limpia y fría.
- NO use acetona, limpiadores abrasivos u otros detergentes especiales para limpiar los paneles transparentes.
- Limpie el producto una vez terminado el montaje.

HERRAMIENTAS Y EQUIPOS

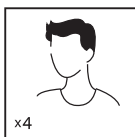

Se necesitan
4 personas



Paño de microfibra

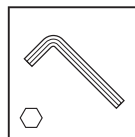

Llave Allen /
Llave hexagonal
5 mm | 5/32"

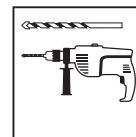

Taladro eléctrico con
broca o mecha
12 mm | 15/32"

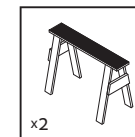

Caballete

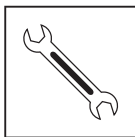

Llave
13 mm | 1/2"



Tijeras

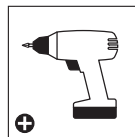

Taladro inalámbrico:
cabeza Philips



Martillo



Guantes de trabajo

ANTES DEL MONTAJE

- Elija con cuidado su ubicación antes de comenzar el ensamblaje.
- El suelo debe estar perfectamente plano y nivelado. Además debe tener una base sólida como hormigón, concreto, deck, etc.
- Extraiga todas las piezas de componentes de sus embalajes. Ordene las piezas y compruebe que están todas usando la lista de contenidos.
- Las piezas deberían colocarse cerca y tenerlas a mano.
Ponga las piezas pequeñas (p. ej. tornillos) en un bol para no perderlas.
- Consulte las limitaciones, requisitos, permisos y a las autoridades locales para la construcción de este cobertizo de jardín.
- Este producto requiere una distancia mínima de 0,5 m alrededor de la piscina.

RECOMENDACIONES IMPORTANTES E INFORMACIÓN GENERAL

- Durante el montaje, ponga algo suave por debajo de las piezas, para evitar que se rayen o estropeen.
- Es esencial sustituir los elementos o grupos de elementos dañados lo antes posible.
- Utilice únicamente las piezas suministradas por Palram, Canopia.
- **Herrajes:** tornillos de acero inoxidable, aluminio y con recubrimiento de níquel-cinc.
- Soportes angulares internos: de acero inoxidable y aluminio.
- Estructura de aluminio.
- Este producto fue pintado según la norma QUALICOAT.
- Asegúrese de que los orificios de anclaje al suelo estén limpios y sin suciedad.
- Le rogamos lea con atención las siguientes instrucciones antes de empezar a montar este producto.
- Siga los distintos pasos en el mismo orden de las instrucciones.
- Guarde las instrucciones en un lugar seguro para poder consultarlas en el futuro.
- **Nota:** Anclar este producto al suelo es esencial para su estabilidad y rigidez.
Es necesario completar esta fase para que su garantía sea válida.
- Apriete todos los tornillos una vez esté completado el montaje

DURANTE EL MONTAJE

- Durante el montaje, se encontrará con diferentes iconos. Para obtener más información, consulte lo siguiente:



- Cuando encuentre el ícono de información, por favor lea con cuidado dicho paso con comentarios y asistencia adicionales.



- Puede utilizar spray lubricante de silicona para facilitar el deslizamiento de los paneles en los contornos. No ponga spray en los paneles.



- Use un martillo de goma si hiciere falta.

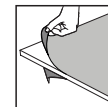

- Asegúrese de quitar la película plástica que cubre ambos lados del panel.



- Todos los paneles que tengan estampado LADO EXTERIOR (THIS SIDE OUT) deben mirar hacia fuera para ofrecer una protección UV completa. Quite la pegatina de plástico una vez los paneles se enganchen en su sitio.

RADY OHĽADNE STAROSTLIVOSTI A BEZPEČNOSTNÁ RADA

- Z dôvodu bezpečnosti výrazne odporúčame, aby výrobok montovali aspoň 4 ľudia.
- Niektoré časti majú kovové hrany. Pri zaobchádzaní s časťami buďte opatrní.
- Nenechávajte ostré alebo tupé predmety pre malé deti.
- Počas montáže vždy noste rukavice, topánky a bezpečnostné okuliare.
- Nesnažte sa altánok zmontovať počas veterného počasia alebo vlhka.
- Nepokúšajte sa o montáž altánku, ak ste unavený, užili ste lieky, drogy alebo alkohol, alebo ak máte sklon k závratom.
- Bezpečne odstráňte všetky plastové obaly – udrzte ich mimo dosahu malých detí.
- Udržujte deti mimo oblasti montáže.
- Pri používaní schodkového rebríka alebo elektrického náradia sa ubezpečte, že nasledujete bezpečnostné pokyny výrobcu.
- Nedovoľte nikomu liezť, stáť alebo kráčať po prístrešku.
- O opory neopierajte ťažké predmety.
- Ak je na streche veľa ťažkého snehu, môže byť nebezpečné stáť či už pod ňou alebo v jej blízkosti.
- Pokiaľ bola farba poškodená počas montáže, môže byť fixovaná.
- Aby sa dodržali vykonané skúšky, musí byť zastrešenie zatvorené a uzamknuté, ak sa nepoužíva.
- Zastrešenie musí byť zatvorené a uzamknuté, ak sa nepoužíva.
- V prípade sneženia sklopte zastrešenie bazéna na konci bazéna.
- Za veterného počasia moduly nesmú zostať uložené v stohovacej polohe.
- Prístrešok musí byť pripevnený k zemi v zatvorenej polohe na bazéne.
- Zastrešenie bazén musí byť uzamknuté, keď sa nepoužíva. Spoločnosť dodáva detskú poisťku.
- Tento produkt nemôže nahradiť dozor rodičov nad deťmi.
- Tento produkt sa smie používať výlučne na zakrytie bazéna.
- Deti v blízkosti bazéna musia byť pod vašim neustálym dozorom a nesmú zostať samé.
- Celý prístup k existujúcim nakloneným alebo pripevneným krytom musí byť zabezpečený vlastníkom.
- Plavecký bazén môže predstavovať nebezpečenstvo pre vaše deti. Ak nevenujete zvláštnu pozornosť, má veľký potenciál utopenia.
- Deti v blízkosti bazéna vyžadujú vašu neustálu bdelosť a aktívny dohľad, aj keď vedia plávať.
- Naučte sa záchranu života.
- Bezpečnosť je zaistená iba vtedy, keď je prístrešok nainštalovaný v súlade s pokynmi výrobcu / distribútora zatvorený a uzamknutý.
- V prípade poruchy, ktorá bráni uzavretiu a zaisteniu bazéna, alebo v prípade dočasnej nedostupnosti zariadenia, urobte všetky potrebné preventívne opatrenia. Určite tomu zabráňte.
- prístup malých detí k bazénu, kým sa neopraví prístrešok.
- Uložte a zverejnite čísla prvej pomoci a čísla miestnych hasičov pri bazéne.

POKYNY NA ČISTENIE

- Keď je potrebné výrobok vyčistiť, použite mäkkú handričku a opláchnite studenou čistou vodou.
- Na čistenie panelov nepoužívajte acetón, abrazívne čističe alebo iné špeciálne čistiace prostriedky.
- Po ukončení montáže vyčistite výrobok.

NÁSTROJE A ZARIADENIE

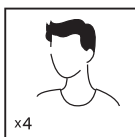

x4

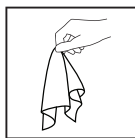
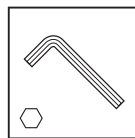
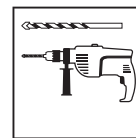
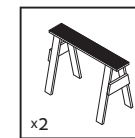
 4 dve osoby

 Utierka z mikrovlákna

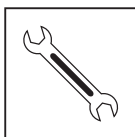
 Imbusový kľúč / šesťhranný kľúč 5 mm | 5/32"

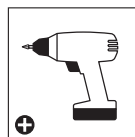
 Elektrická vŕtačka s vrtákom 12 mm | 15/32"

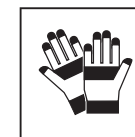
x2

 Kozlíček / Koza na rezanie dreva

 Nastaviteľný kľúč 13 mm | 1/2"

 Nožnice

 Akumulátorová vŕtačka - krížová hlava

 Kladivo

 Pracovné rukavice

PRED MONTÁŽOU

- Miesto montáže si opatrne vyberte skôr, než s montážou začnete.
- Povrch zeme musí byť dokonale rovný a musí mať pevnú základňu, napríklad betón, asfalt, plošinu, atď.
- Zoradte si všetky časti a porovnajte ich so zoznam častí.
- Súčiastky si rozložte tak, aby ste ich mali poruke. Malé súčiastky (šróby, atď.) dajte do misky, aby sa nestratili.
- Prosím, poraďte sa so svojím miestnym orgánom prípadné povolenie je potrebné vystavať zápojom.
- Tento produkt vyžaduje minimálny priestor okolo bazéna 0,5 m.

DÔLEŽITÉ ODPORÚČANIA

- Počas montáže použite pod časťami mäkký povrch, aby ste sa vyhlili poškrabaniu a poškodeniu.
- Je nevyhnutné vymeniť poškodenú položku alebo súpravu položiek čo možno najskôr
- Používajte iba diely dodávané spoločnosťou Palram - Canopia.
- **Vybavenie:** skrutky s povrchovou úpravou z nehrdzavejúcej ocele, hliníka a zmesi nikla a zinku.
- Konzoly vnútorných uhlov: nehrdzavejúca oceľ a hliník.
- Hliníková konštrukcia.
- Tento produkt je lakovaný podľa normy QUALICOAT.
- Uistite sa, že kotviace otvory v zemi sú čisté a bez nečistôt.
- Pred začatím montáže tohto výrobku si, prosím, dôkladne prečítajte tieto pokyny.
- Skôr, než začnete s montážou výrobku, si dôkladne prečítajte tieto pokyny.
- Kroky vykonávajte v poradí uvedenom v týchto pokynoch.
- Pokyny si odložte na bezpečné miesto, aby ste ich mohli v budúcnosti znova použiť.
- **Prosím všimnite si!** Ukotvenie tohto výrobku na zem, je potrebné pre jeho stabilitu a tuhosť. Vyžaduje sa na dokončenie tejto fázy, aby platila záruka.
- Po skončení montáže utiahnite všetky skrutky.

POČAS MONTÁŽE

- Pri montáži sa stretnete s rôznymi ikonami pre rôzne výrobky. Ďalšie informácie nájdete nižšie:



- Pri montáži sa stretnete s informačným symbolom, pozrite sa do príslušného montážneho kroku pre ďalšie pripomienky a pomoc.



- Môžete použiť silikónový lubrikačný sprej pri zasúvaní panelov do profilov. Nestriekajte na panely.



- V prípade potreby použite gumové kladivo.

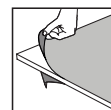

- Táto ikona označuje, že montér sa má nachádzať vo vnútri výrobku.

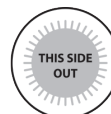

- Všetky panely s označením "THIS SIDE OUT" musia byť obrátené smerom von, aby sa vytvorila úplná ochrana proti UV žiareniu. Odstráňte plastovú nálepku, pretože panely sú zablokované na mieste.

BIZTONSÁGI TANÁCSOK ÉS KEZELÉSI

- Biztonsági okokból javasoljuk, hogy a terméket legalább 4 ember szerelje össze.
- Egyes részek fémszegélyekkel rendelkeznek. Kérjük, legyen óvatos az alkatrészekkel való munka során. Mindig viseljen kesztyűt, cipőt és védőszemüveget az összeszerelés során.
- Ne kísérelje meg a termék szeles, vagy nedves körülmények között összeszerelni.
- Ne hagyjon éles vagy tompa tárgyakat a kisgyermek számára.
- Ne próbálja meg összeszerelni a termék, ha fáradt, ha kábítószert fogyasztott, ha gyógyszert vett be, vagy alkoholt fogyasztott, vagy ha hajlamos a szédülésre.
- Az összes műanyag zacskót óvatosan távolítsa el - tartsa ezeket távol a kisgyermekektől.
- Tartsa távol a gyermekeket az összeszerelési területtől.
- Ha létrát, vagy elektromos kéziszerszámokat használ, ügyeljen arra, hogy mindig kövesse azon gyártók biztonsági előírásait.
- Ne engedje, hogy bárki másszon, álljon vagy járjon a menedékházon.
- Nehéz tárgyakat nem szabad a pilléreknek támasztani.
- A tetőn lévő nehéz hó miatt nem biztonságos a tető alatt és a közelében állni.
- Ha az összeszerelés során megkarcolódik a festés, az a későbbiekben javítható.
- Az elvégzett teszteknek megfelelően a medencefedést csukni és zárni kell, amikor az nincs használatban.
- A medencefedést csukni és zárni kell, amikor az nincs használatban.
- Hó esetén hajtsa le a medencefedést a medence végéig.
- Szeles időben a modulokat tilos egymásra rakott helyzetben hagyni.
- A medencefedést a medence zárt állapotában kell a talajhoz rögzíteni.
- Ezt a medencefedést zárni kell, amikor használaton kívül van, gyerekzárát a cég biztosít.
- Ez a termék nem pótolja a gyerekek szülői felügyeletét.
- Ez a termék kizárólag medence befedésére használható.
- Az úszómedence közelében lévő gyerekekre állandóan felügyelni kell, tilos őket magukra hagyni.
- **A meglévő, a hajlított vagy rögzített burkolatokhoz való minden hozzáférést a tulajdonosnak kell biztosítania.**
- **Az uszoda veszélyt jelenthet gyermekeire. A fulladás nagy eséllyel fordulhat elő, ha nem fordítanak különös figyelmet.**
- **Az uszoda közelében lévő gyermekek folyamatos éberséget és aktív felügyeletet igényelnek, még ha tudnak is úszni.**
- **Ismerje meg az életmentő mozdulatot.**
- **A biztonság csak akkor biztosított, ha a gyártó / forgalmazó utasításainak megfelelően telepített menedéket bezárják és reteszelik.**
- **Olyan meghibásodás esetén, amely megakadályozza a medence bezárását és rögzítését, vagy ha a berendezés ideiglenesen nem érhető el, tegyen meg minden szükséges óvintézkedést. Ügyeljen arra, hogy megakadályozza.**
- **kisgyermekek hozzáférhetnek a medencéhez, amíg a menedéket meg nem javítják.**
- **Az elsősegély és a helyi tűzoltóság számát tartsa és tegye a medence mellé.**

TISZTÍTÁSI ÚTMUTATÓ

- Ha a terméket meg kell tisztítani, használjon puha ruhát, és öblítse le hideg tiszta vízzel.
- A panelek tisztításához ne használjon acetont, súrolószereket, vagy egyéb speciális tisztítószerket.
- A terméket csak a felszerelést követően tisztítsa meg.

SZERSZÁMOK ÉS KÉSZÜLÉKEK

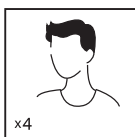

x4

- Az összeszereléshez 4 emberre van szükség

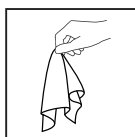

- Mikroszálas kendő

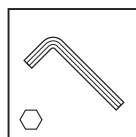

- Imbuszkulcs 5 mm | 5/32"

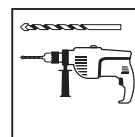

- Elektromos fúró, fúrószárral 12 mm | 15/32"

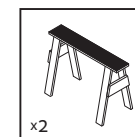

x2

- Fűrészbak

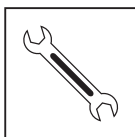

- Csavarkulcs 13 mm | 1/2"

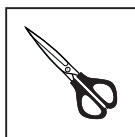

- Olló

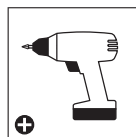

- Akkumulátoros fúró, Philips szárral (bittel)



- Kalapács



- Védőkesztyű

ELŐKÉSZÜLET AZ ÖSSZESZERELÉSHEZ

- Mielőtt megkezdene az összeszerelést, gondosan válassza meg annak helyét.
- A alapnak tökéletesen síknak és egyenletesnek, valamint szilárdnak kell lennie, például beton, aszfalt, hajópadló stb.
- Ellenőrizze az alkatrészeket a tartalomjegyzéket alapján.
- Az alkatrészeket lehetőleg a közelben helyezze el. Tartsa a kis alkatrészeket (csavarokat stb.) egy tálban, hogy ne vesszenek el.
- Kérjük, forduljon a helyi hatósághoz, ha engedélyköteles az termék felépítése.
- A termék szereléséhez legalább 0,5 m szabad hely szükséges a medence körül.

FONTOS AJÁNLÁSOK

- Az összeszerelés során használjon valamilyen puha borítást a talajon, hogy elkerülje az alkatrészek megkarcolódását, vagy egyéb károkat.
- Sérült alkatrész vagy alkatrész készlet mihamarabbi cseréje létfontosságú.
- Csak a Palram - Canopia által szállított alkatrészeket használjon fel.
- Fémrészek: rozsdamentes acél, alumínium és nikkel-cink bevonatú csavarok.
- Belső sarokbilincsek: rozsdamentes acél és alumínium.
- Alumínium szerkezet.
- Ennek a terméknek a festése a QUALICOAT szabvány alapján készült.
- Ügyeljen arra, hogy a talajon a rögzítésre szolgáló furatok piszoktól mentesek legyenek.
- A termék összeállítása előtt kérjük, olvassa át alaposan ezeket az utasításokat.
- A lépéseket az útmutatónak megfelelő sorrendben végezze el.
- Tartsa meg ezt az útmutatót egy biztonságos helyen, hogy később is használhassa.
- **Kérjük, vegye figyelembe:** A termék rögzítése a talajhoz elengedhetetlen annak stabilitásához és merevségéhez.
- Ezt a jótállás érvényesítése érdekében is el kell végezni.
- Az összeszerelés végén szorítson meg minden csavart még egyszer.

A SZERELÉS SORÁN

- Az összeszerelés során a különböző termékeknek különböző ikonokkal fog találkozni. További információkat az alábbiakban talál:



- Ha az információs ikont látja, nézzen utána a hozzá tartozó összeállítási lépésnek, valamint a további megjegyzéseknek és segítségnek.



- Az oldaltábláknak a szelvényekve csúsztatásakor használhat szilikon sprayt. Ne permetezze a paneleket.



- Ha szükséges, használjon gumikalapácsot.

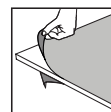

- Ne felejtse el eltávolítani a burkoló műanyag fóliát a panel mindkét oldaláról.

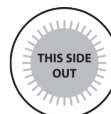

- A teljes UV-védelem biztosításához minden, a "THIS SIDE OUT" ("ezzel az oldallal kifelé") felirattal megjelölt panelnek kifelé kell néznie. Amint a paneleket a helyükre rögzítette, húzza le róluk a műanyag matricákat.

BEZPEČNOSTNÍ RADA

- Z bezpečnostních důvodů Vám důrazně doporučujeme, aby produkt montovaly alespoň 4 osoby.
- Některé součásti mají kovové hrany. Při manipulaci buďte proto opatrní.
- Během montáže používejte ochranné rukavice, obuv a bezpečnostní brýle.
- Nenechávejte ostré nebo tupé předměty pro malé děti.
- Nepokoušejte se provádět montáž produkt za větrného nebo deštivého počasí.
- Nepokoušejte se provádět montáž produkt, jestliže jste unavení, požíli jste drogy, léčiva nebo alkohol, nebo pokud máte sklon k závratím.
- Všechny plastové sáčky nebo tašky odkládejte bezpečná místa – přechovávejte je mimo dosah dětí.
- Nepouštějte děti na montážní pracoviště.
- Budete-li používat žebřík nebo nástroje s mechanickým pohonem, zajistěte, abyste postupovali podle bezpečnostních doporučení výrobce.
- O stejné tyče neopírejte žádné těžké předměty.
- Nedovolte nikomu šplhat, stát nebo kráčet po útluku.
- Střechu a okapy udržujte bez sněhu, nečistoty a listí.
- Silné zatížení sněhem na střeše může být nebezpečné když stojíte pod střešou nebo v její blízkosti.
- Hvis farve blev ridset under montage, kan den løses.
- Aby byla zajištěna shoda s provedenými testy, zastřešení musí být v době, kdy se nepoužívá, zavřené a uzamknuté.
- V době, kdy se nepoužívá, musí být zastřešení zavřené a uzamknuté.
- V době, kdy sněží, je zastřešení třeba umístit ve složené poloze na konci bazénu.
- Za větrného počasí by moduly neměly zůstat naskládané jeden na druhém.
- Po umístění v zavřené poloze nad bazénem musí být přístřešek připevněn k zemi.
- Toto bazénové zastřešení je nutno uzamykat v době, kdy se nepoužívá.
- Výrobce dodává dětskou pojistku zámku.
- Tento výrobek nelze považovat za náhradu dohledu rodičů nad dětmi.
- Tento výrobek by měl být používán výhradně k zakrývání bazénů.
- Děti zdržující se v blízkosti bazénu vyžadují váš neustálý dohled a nesmějí zůstat o samotě
- Veškerý přístup ke stávajícím nakloněným nebo připojeným krytům musí být zajištěn vlastníkem.
- Plavecký bazén může představovat nebezpečí pro vaše děti. Pokud nevenujete zvláštní pozornost, má velký potenciál utonutí.
- Děti u bazénu vyžadují vaši neustálou bdělost a váš aktivní dohled, i když umí plavat.
- Naučte se zachránit život.
- Bezpečnost je zajištěna pouze tehdy, když je přístřešek instalovaný podle pokynů výrobce / distributora uzavřen a uzamčen.
- V případě poruchy, která brání uzavření a zajištění bazénu, nebo v případě dočasné nedostupnosti zařízení, proveďte veškerá nezbytná opatření. Nezapomeňte tomu zabránit
- přístup malých dětí do bazénu, dokud nebude přístřešek opraven.
- Uchovávejte a zveřejňujte čísla první pomoci a čísla místních hasičů u bazénu.

NÁVOD K ČIŠTĚNÍ

- Když je třeba výrobek vyčistit, použijte měkký hadřík a opláchněte studenou čistou vodou..
- K čištění panelů nepoužívejte aceton, drhnoucí čisticí prostředky, ani jiné speciální odmašťovací prostředky.
- Po dokončení montáže očistěte produkt.

NÁSTROJE A ZAŘÍZENÍ

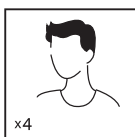

x4

- Potřebné 4 osoby

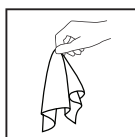

- Utěrka z mikrovlákna

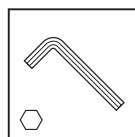

- Imbusový klíč / šestihřanný klíč 5 mm | 5/32"

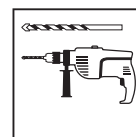

- Elektrická vrtačka s vrtákem 12 mm | 15/32"

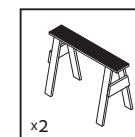

x2

- Kozlíček / Koza na řezání dřeva

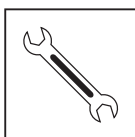

- Klíč 13 mm | 1/2"



- Nůžky

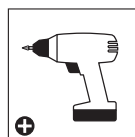

- Akumulátorová vrtačka - křížová hlava

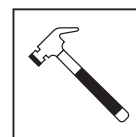

- Kladivo



- Pracovní rukavice

ŠROUBOVÁK S KŘÍŽOVOU HLAVOU

- Před montáží si pečlivě zvolte umístění.
- Povrch země musí být dokonale plochý a vyrovnaný a mít pevnou základnu, jako je beton, asfalt, apod.
- Třídte součásti a zkontrolujte je podle seznamu obsahu dílů.
- Součásti by měly být umístěné na dosah ruky. Udržujte všechny malé součástky (šrouby, atd.) v misce proto, aby se neztratily.
- Obratťe se prosím na místní orgány, pokud jsou před výstavbou požadována jakákoliv povolení pro produkt.
- Tento výrobek vyžaduje minimální volnou vzdálenost 0,5 m okolo bazénu.

DŮLEŽITÁ DOPORUČENÍ

- Při montáží podložte součásti něčím s měkkým povrchem, abyste zamezili vzniku škrábanců a poškození.
- Jakýkoli díl nebo jakoukoli sadu dílů je v případě potřeby naprosto nezbytné co nejdříve vyměnit.
- Používejte pouze díly dodávané společností Palram - Canopia.
- **Montážní díly:** šrouby z nerezavějící oceli, hliníku a oceli opatřené nikl-zinkovým povlakem.
- Vnitřní úhlové držáky: nerezavějící ocel a hliník.
- Hliníková konstrukce.
- Tento výrobek je opatřen nátěrem podle normy QUALICOAT.
- Ujistěte se, že kotvicí otvory, které jsou připraveny v zemi, jsou přístupné a neobsahují nečistoty.
- Než zahájíte montáž tohoto produktu, přečtěte si prosím pozorně tento návod.
- Všechny kroky prosím proveďte v pořadí uvedeném v tomto návodu.
- Tento návod si uschovejte na bezpečném místě pro budoucí potřebu.
- **Upozornění:** Ukotvení tohoto produktu k zemi je nezbytné pro jeho stabilitu a pevnost. Aby byla vaše záruka platná, je nutné dokončit tento krok.
- Na konci montáže utáhněte všechny šrouby.

POZNÁMKY BĚHEM MONTÁŽE

- Při montáži se setkáte s různými ikonami u různých produktů. Další informace naleznete níže:



- Když narazíte na informační ikonu, podívejte se prosím na příslušný montážní krok na doplňující komentáře a rady.



- Můžete použít silikonový lubrikační sprej, aby vám panely sklouzly lépe do profilů. Nesprejujte na panely.



- Použijte gumovou paličku, pokud je to nutné.

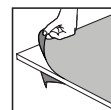

- Ujistěte se, že jste z obou stran panelu odstranili krycí plastovou fólii.

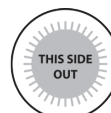

- Vezměte prosím na vědomí, že panely instalujete stranou s ochranou proti UV záření ven (označeno "THIS SIDE OUT"). Odstraňte plastovou nálepku, když panely budou na místě.



IMPORTANT ASSEMBLY STEPS

When encountering this information icon during assembly, please refer the relevant assembly step for important additional comments.

- Step 2:** In diagrams a, b, c use profiles from **step 1**.
- Step 93:** Child safety “Push ‘n Lock” system.
- Steps 95+97:** In **Drawing b** part **#9212** should be locked by pushing and screwing.
- Steps 95+97:** Clean and dry the profile with a cloth before attaching the “warning label” as shown in **Drawing c**. The label marks the locking area for child safety.
- Step 98:** Do not anchor the product to the ground before completing steps **95 + 97**.
The screws and masonry anchors supplied with the kit are suitable for concrete fixing only.
Please consult customer service regarding which fasteners are suitable for other surfaces types (not supplied).
- Step 99:** In **Drawing c** part **#9488** should be locked by pushing and screwing.



PRINCIPALES ÉTAPES D'ASSEMBLAGE

Lorsque vous rencontrez cette icône d'information pendant l'assemblage, veuillez vous référer à l'étape d'assemblage correspondante pour d'autres commentaires importants.

- Étape 2:** Dans les **diagrammes a, b, c**, utilisez les profils de **l'étape 1**.
- Étape 93:** Système de sécurité enfant “Push'n'Lock”.
- Étapes 95+97:** Sur le **Diagramme b**, la pièce **#9212** doit être fixée en la poussant et la vissant.
- Étapes 95+97:** Nettoyez et séchez le profilé avec un chiffon avant de coller “l'étiquette de sécurité” comme montré dans le **Diagramme c**. L'étiquette indique la zone de verrouillage pour sécurité enfant.
- Étape 98:** N'ancrez pas le produit au sol avant d'avoir terminé les étapes **95 + 97**.
Les vis et les chevilles pour maçonnerie fournies avec le kit ne conviennent que pour fixer du béton.
Veuillez consulter service clients pour savoir quelles fixations sont adaptées aux terrasses en bois (non fournis).
- Étape 99:** Sur le **Diagramme c**, la pièce **#9488** doit être fixée en la poussant et la vissant.



WICHTIGE MONTAGESCHRITTE

Wenn Sie bei der Montage auf dieses Informationssymbol stoßen, finden Sie im jeweiligen Montageschritt wichtige Zusatzhinweise.

- Schritt 2:** Verwenden Sie in den Diagrammen a, b, c Profile aus **Schritt 1**.
- Schritt 93:** Kindersicherung "Push 'n Lock"-System.
- Schritte 95+97:** In **Diagramm b** sollte Teil **Nr. 9212** durch Drücken und Schrauben befestigt werden
- Schritte 95+97:** Reinigen und trocknen Sie das Profil mit einem Tuch, bevor Sie das in Abbildung **Diagramm c** "Warnschild" anbringen. Das Warnschild markiert den Verriegelungsbereich für die Kindersicherung.
- Schritt 98:** Verankern Sie das Produkt solange nicht am Boden, bis Sie **Schritte 95 + 97** ausgeführt haben.
Die mit dem Bausatz gelieferten Schrauben und Maueranker sind nur für die Befestigung auf Beton.
Bitte fragen Sie einen Kundendienst, welche Befestigungsmittel für andere Untergründe geeignet sind (nicht im Lieferumfang enthalten).
- Schritt 99:** In **Diagramm c** sollte Teil **Nr. 9488** durch Drücken und Schrauben befestigt werden.



PASOS DE MONTAJE IMPORTANTES

Al encontrar este icono de información durante el montaje, consulte el paso de montaje correspondiente para obtener importantes comentarios adicionales.

- Paso 2:** En los diagramas a, b, c se utilizan las reseñas del **paso 1**.
- Paso 93:** Sistema de seguridad para niños "Empujar y bloquear".
- Pasos 95+97:** En el **dibujo b** la pieza **#9212** debe bloquearse empujando y atornillando.
- Pasos 95+97:** Limpie y seque el perfil con un paño antes de colocar la "etiqueta de advertencia" como se muestra en el **dibujo c**.
La etiqueta marca la zona de cierre para la seguridad los niños.
- Paso 98:** No ancle el producto al suelo hasta que haya realizado los **pasos 95 + 97**.
Los tornillos y anclajes de pared suministrados con el kit sólo son adecuados para la fijación de hormigón.
Pregunte a Servicio al Cliente qué elementos de fijación son adecuados para otro tipo superficie (no incluidos).
- Paso 99:** En el **dibujo c**, la pieza **#9488** debe bloquearse empujando y atornillando.



DÔLEŽITÉ MONTÁŽNE KROKY

Keď sa počas montáže stretnete s touto informačnou ikonou, ďalšie dôležité poznámky nájdete v príslušnom montážnom kroku.

- Krok 2:** V diagramoch a, b, c použite profily z **kroku 1**.
- Krok 93:** Bezpečnosť detí „Systém Push 'n Lock“ (stlačte a uzamknite).
- krokov 95+97:** V **diagrame b** by sa mala časť **#9212** zaistiť zatlačením a zaskrutkovaním.
- krokov 95+97:** Pred nalepením „výstražného štítku“ podľa **diagrame c** profil očistite a osušte. Štítok označuje oblasť uzamknutia kvôli bezpečnosti detí.
- Krok 98:** Pred vykonaním krokov **95 + 97**, výrobok neukotvujte do zeme. Skrutky a kotvy do muriva dodávané so súpravou sú vhodné iba na pripevnenie k betónu. Poradte sa s zákaznícky servis o tom, ktoré upevňovacie prvky sú vhodné pre iné typy povrchov (nie sú súčasťou balenia).
- Krok 99:** V **diagrame c** by sa mala časť **#9488** zaistiť zatlačením a zaskrutkovaním



FONTOS ÖSSZESZERELÉSI LÉPÉSEK

Amikor összeszerelés során ezzel az információs ikonnal találkozik, úgy kérjük, olvassa el a vonatkozó összeszerelési lépést a további fontos megjegyzésekkel kapcsolatban.

- 2. lépés:** Az a, b, c ábrákon az **1. lépés** profiljait használja.
- 93. lépés:** Push 'n Lock" rendszer, a gyermekek biztonságáért.
- 95.+97. lépés:** A **b)** ábrán a **9212**-es elemet csavarozás közben nyomva kell rögzíteni.
- 95.+97. lépés:** A "figyelmeztető címke" felhelyezése előtt tisztítsa és szárítsa meg a profilt ruhával, amint azt **a c)** ábra is mutatja. Ez a címke jelöli a lezárás területét a gyermekek biztonsága érdekében.
- 98. lépés:** Ne rögzítse a terméket a **földre a 95. + 97.** lépés végrehajtása előtt. A készlethez mellékelte csavarok és alapzati horgonyok csak betonra történő rögzítésre alkalmasak. Kérjük, konzultáljon egy ügyfélszolgálatot arról, hogy mely rögzítőelemek alkalmasak más típusú felületekhez (nem tartozék).
- 99. lépés:** A **c)** ábrán a **9488**-as elemet csavarozás közben nyomva kell rögzíteni.



DŮLEŽITÉ MONTÁŽNÍ KROKY

Když se během montáže setkáte s touto informační ikonou, další důležité poznámky najdete v příslušném montážním kroku.

- Krok 2:** V diagramech a, b, c použijte profily z **kroku 1**.
- Krok 93:** Dětská pojistka „Push‘ n Lock“ metoda.
- kroků 95+97:** V **diagramu b** by měla být část # **9212** zajištěna zatlačením a přišroubováním.
- kroků 95+97:** Před připevněním „výstražného štítku“ profil očistěte a osušte hadříkem, jak je znázorněno na **diagramu c**. Štítek označuje místo uzamčení pro bezpečnost dětí
- Krok 98:** Nekotvěte výrobek před dokončením **kroků 95 + 97**. Šrouby a kotvy do zdiva dodávané se sadou jsou vhodné pouze pro připevnění k betonu. Poradte se prosím s službou zákazníkům, které spojovací prvky jsou vhodné pro jiné typy povrchů (nejsou součástí dodávky).
- Krok 99:** V **diagramu c** by měla být část # **9488** zajištěna zatlačením a zašroubováním.



HOW TO ASSEMBLE

MAJORCA™ 13x24 / 4x8

IMPORTANT!

Please read these instructions carefully before starting assembly.
Keep these instructions in a safe place for future reference.

www.canopia.com

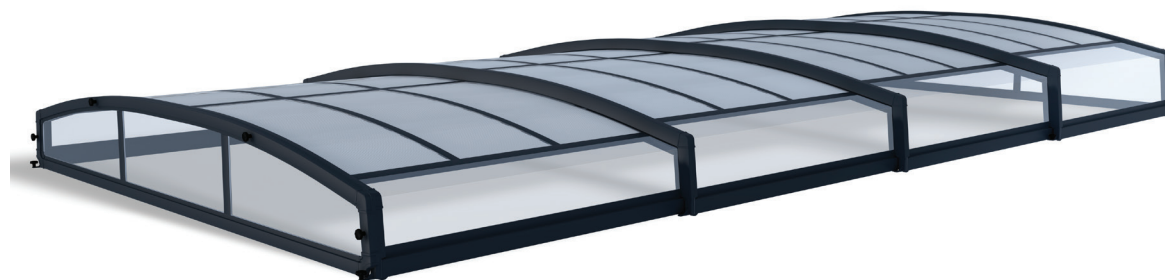

A member of Palram Industries Ltd.



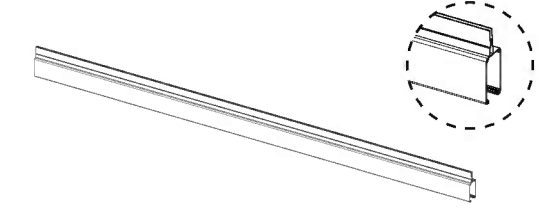
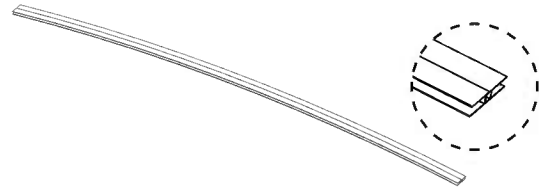
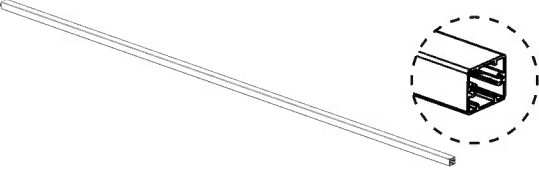
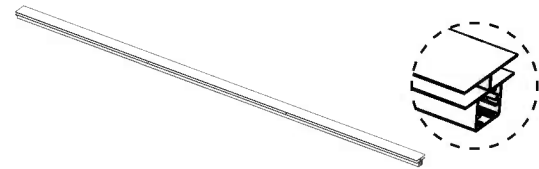
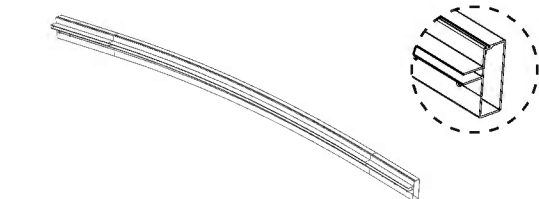
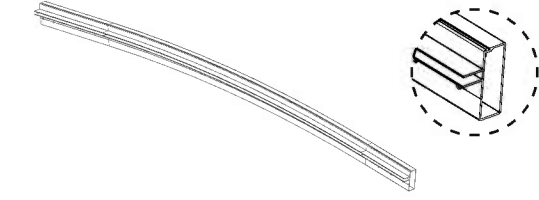

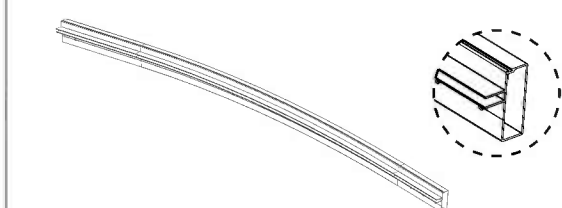
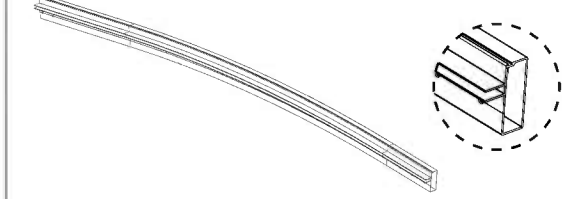
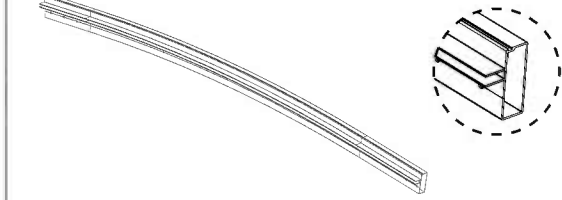
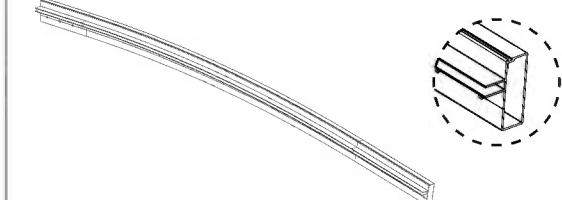
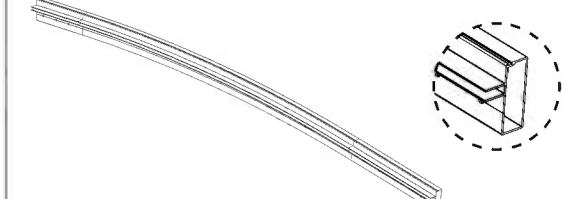
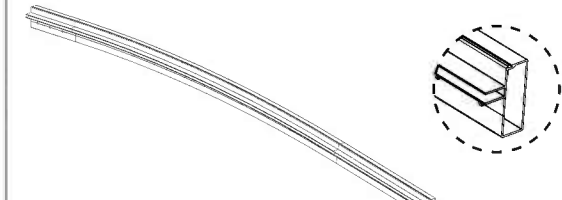
Contents

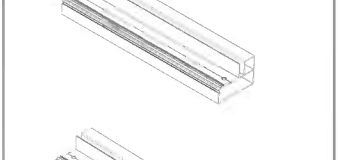
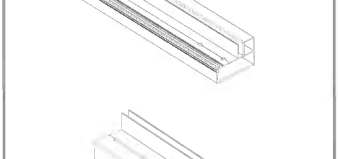
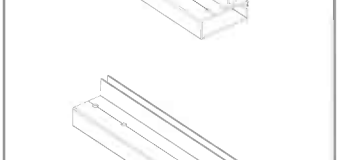
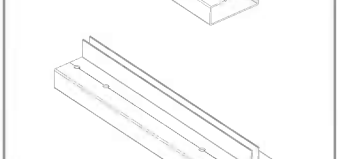
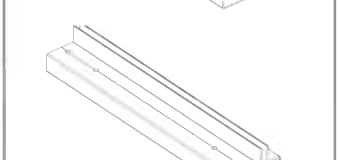

Item		Qty.
9086		8
9051		16
9052		16
9053		12
9054		1
9055		1

Item		Qty.
9056		1
9057		1
9058		1
9059		1
9060		1
9061		1

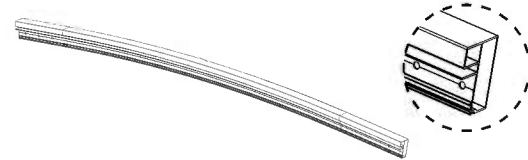
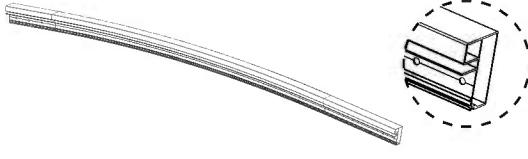
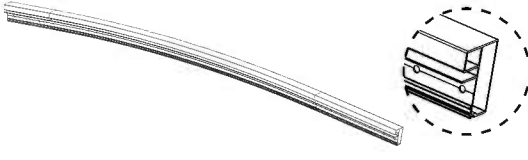
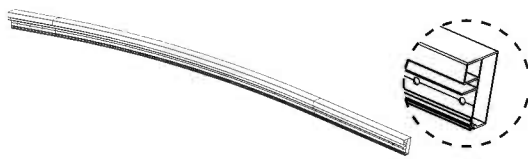
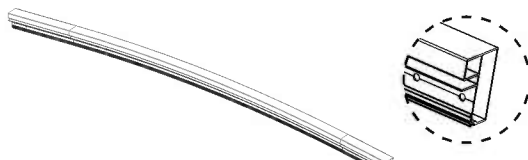
Item		Qty.
9078		2
9079		2
9080		2
9081		2
9062		2
9063		2
9064		2
9065		2

Contents

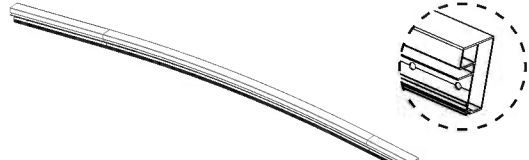
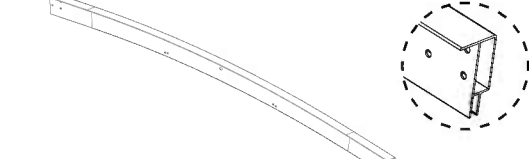
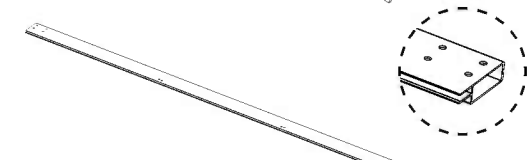
Item		Qty.
9070		1
9071		1
9072		1
9073		1
9074		1
9075		1
9076		1

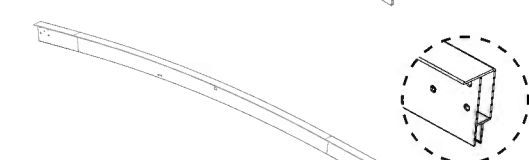
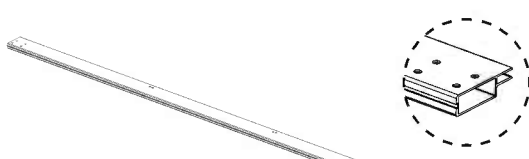

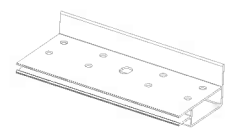
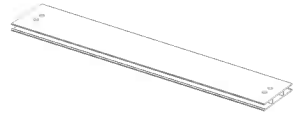
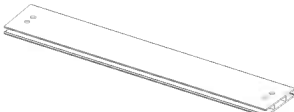
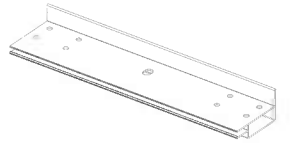
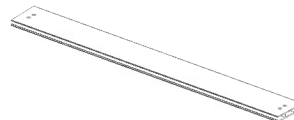
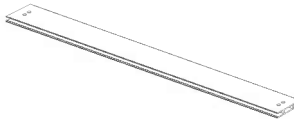
Item		Qty.
9077		1
9199		2
9205		2
9201		1
9202		1
9206		2

Item		Qty.
9203		2
9207		1
9208		1
9204		2
9209		1
9210		1

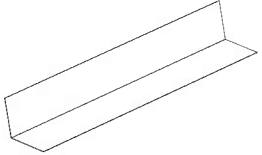
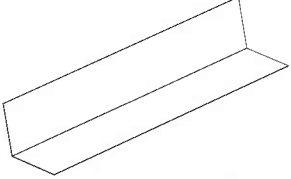
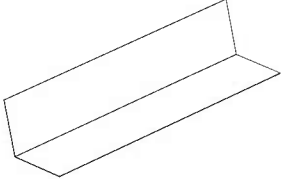
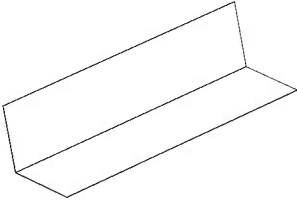
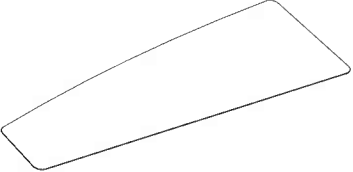
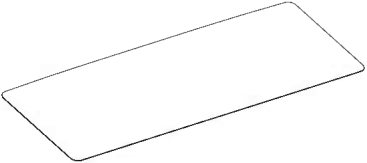
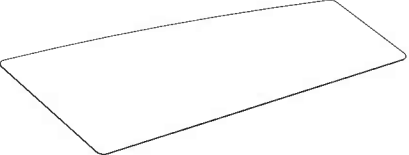

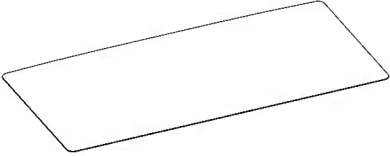
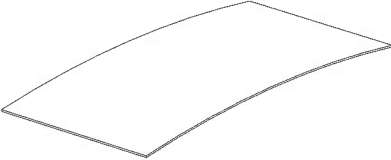
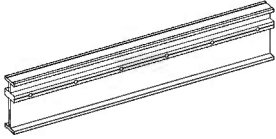
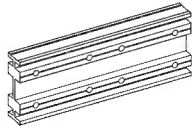
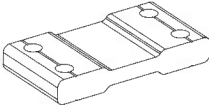
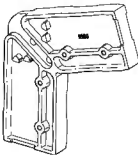
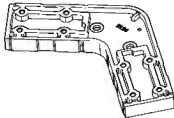
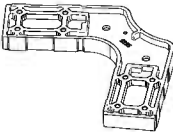

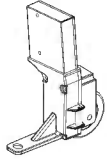
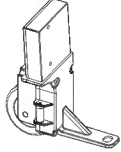
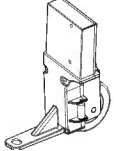

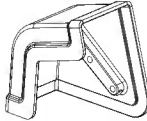
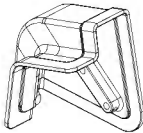
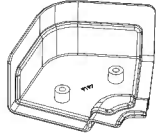
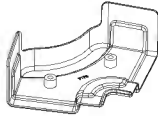
Contents

Item		Qty.
9175		2
9176		2
9177		2
9178		2
9179		2
9180		1
9181		2

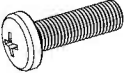
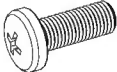

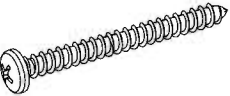
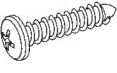
Item		Qty.
9182		1
9174		24
9185		8
9193		4
9196		8
9186		16
9194		4
9195		4

Item		Qty.
9191		4
9192		4
9189		4
9190		4
9187		8
9188		8
9197		4
9198		4

Contents

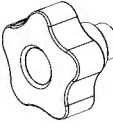
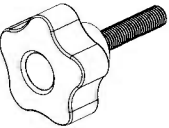
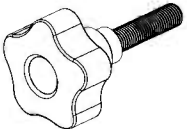
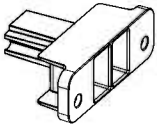
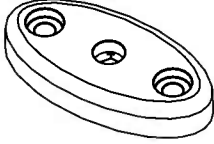
Item		Qty.
9066		144 (+14)
9067		128 (+12)
9068		48 (+4)
9069		64 (+6)
9082		224 (+20)
9083		48 (+4)
9084		8
9489		10 (+1)
9490		10 (+1)

Item		Qty.
9211		4
9212		4
9213		8
9488		2
9183		56 (+2)
9184		8

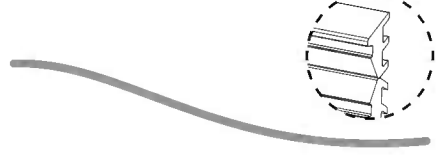
Item		Qty.
8349		8
9085		30
8348		17
8479		1
9710	<div data-bbox="1675 1090 2011 1241" style="border: 1px solid black; padding: 5px;"> <p> MAJORCA™ - Pool Enclosure Abri de Piscine Télescopique LOCKED ACCESS = SECURITY ACCÈS VERROUILLÉ = SÉCURITÉ Serial Number / N ° DE LOT : 0001 </p> </div>	4 (+1)

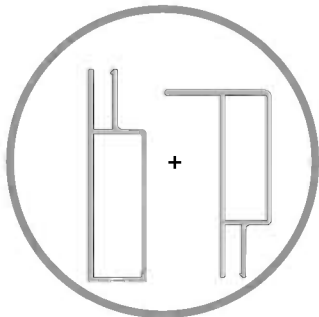
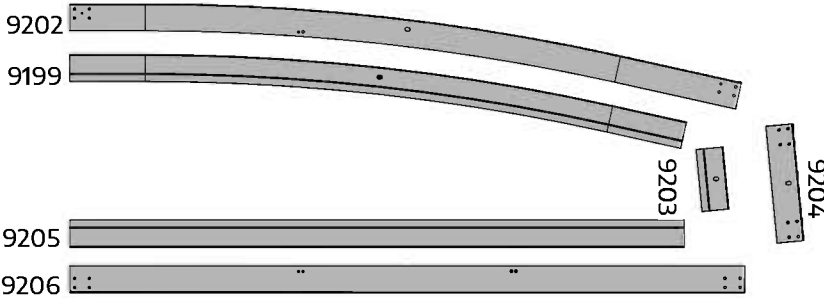
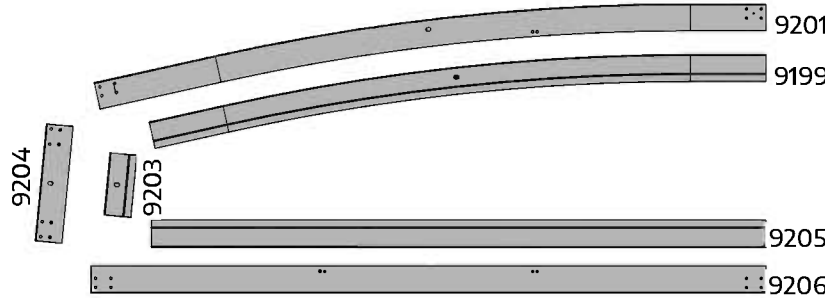
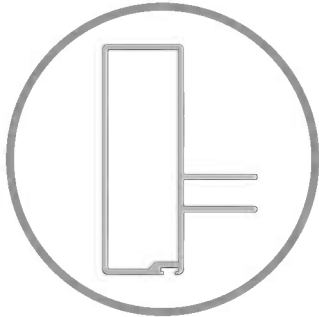
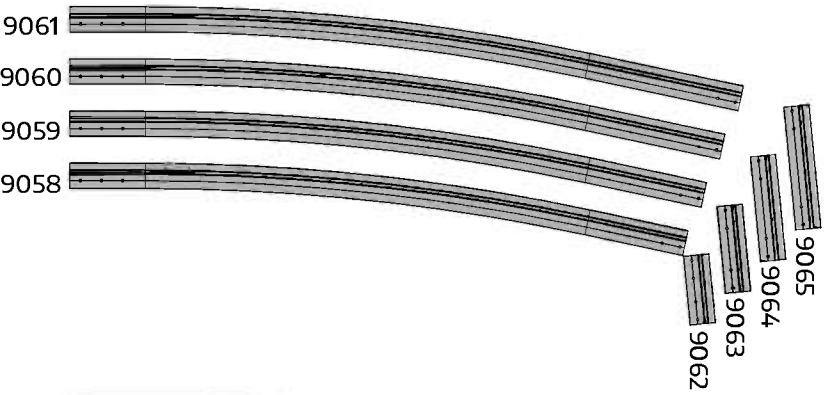
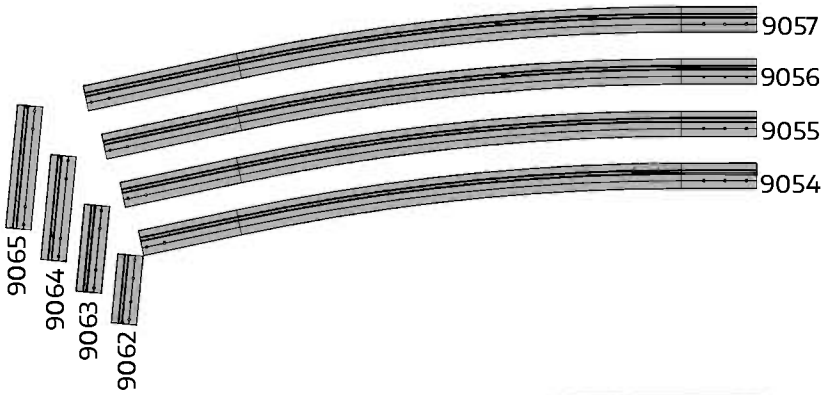
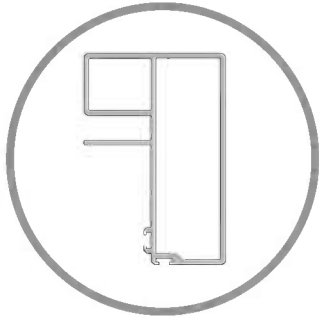
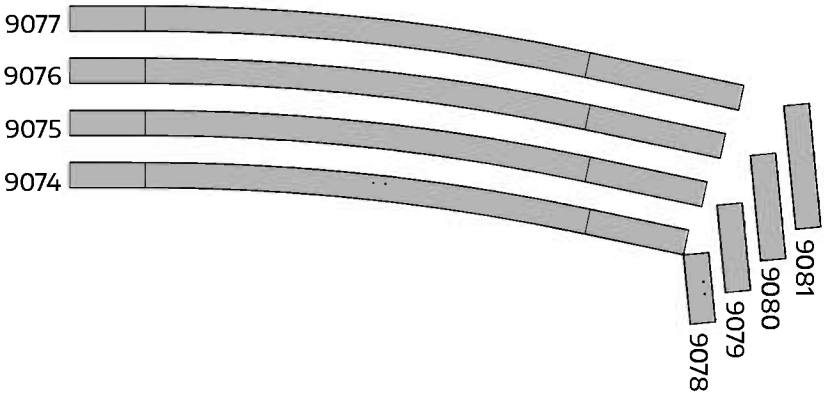
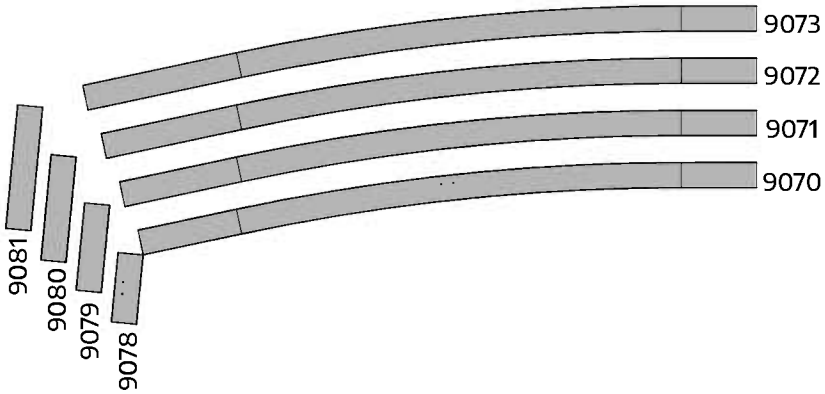
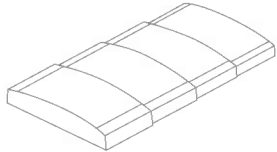

2



in diagrams **a, b, c** use profiles from step 1

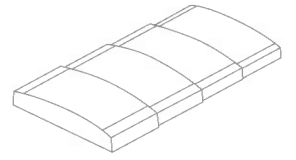

8349



..... 8

9085

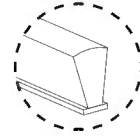

..... 30

9083

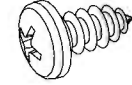

..... 16

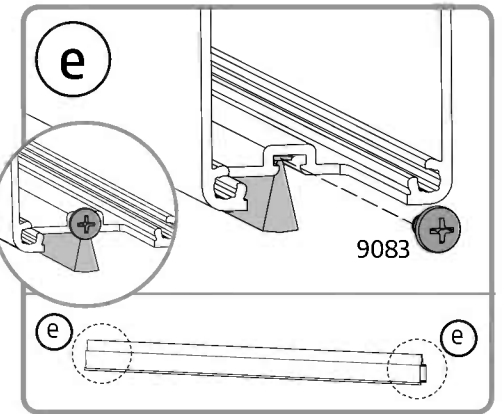
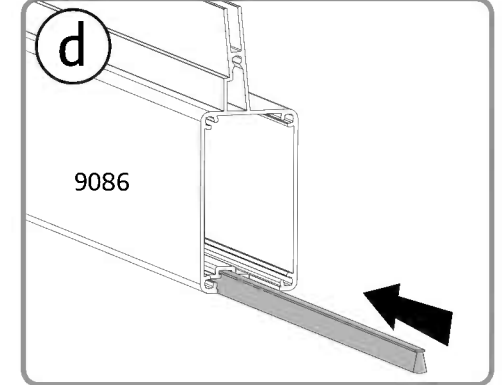
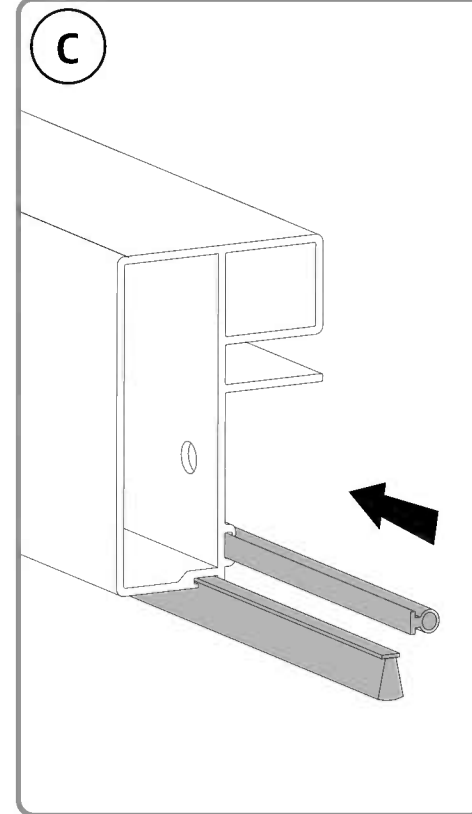
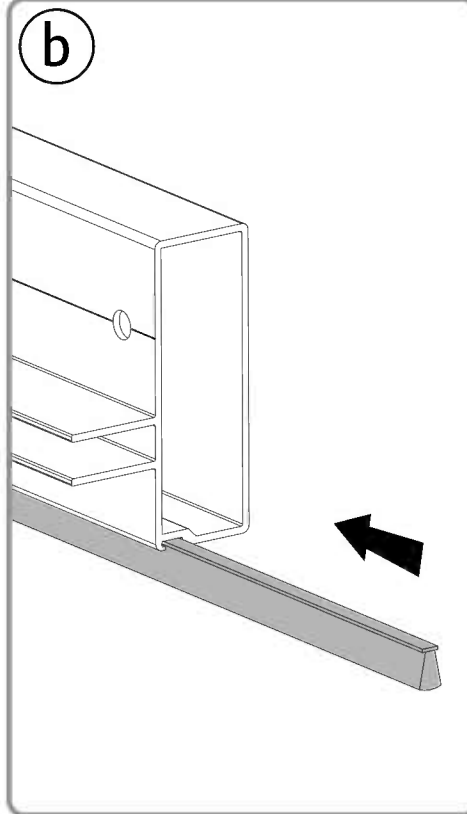
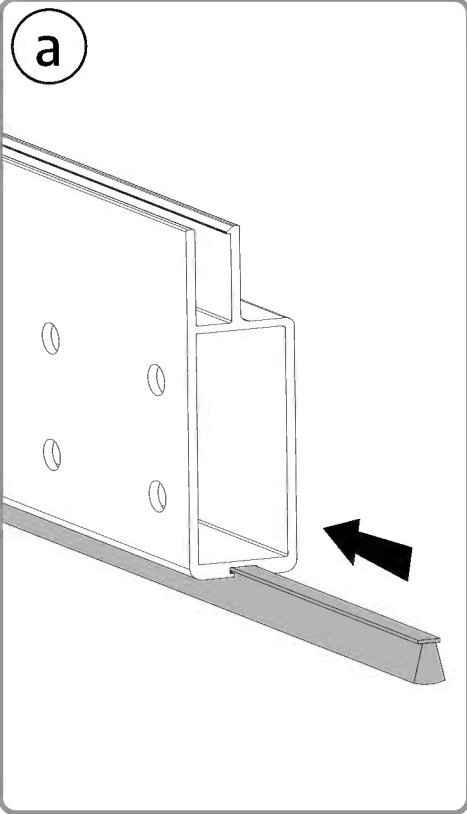

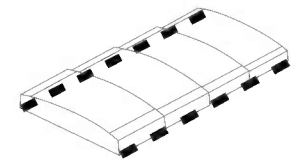

- 9086 8
- 9069 64
- 9190 4
- 9192 4
- 9191 4
- 9189 4

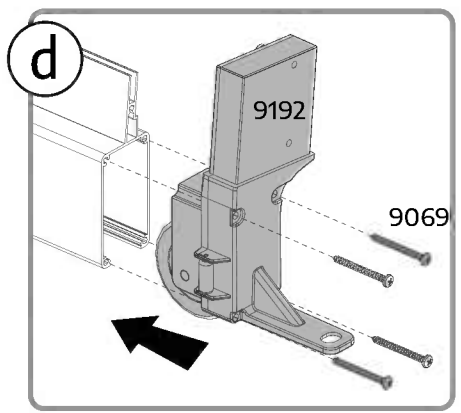
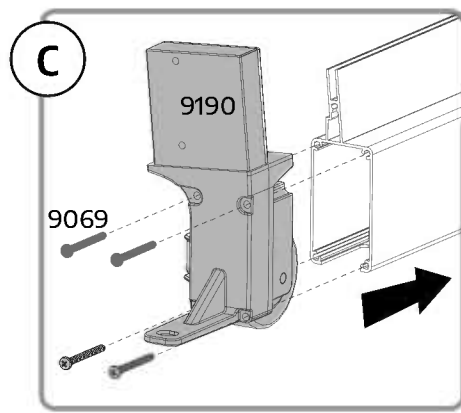
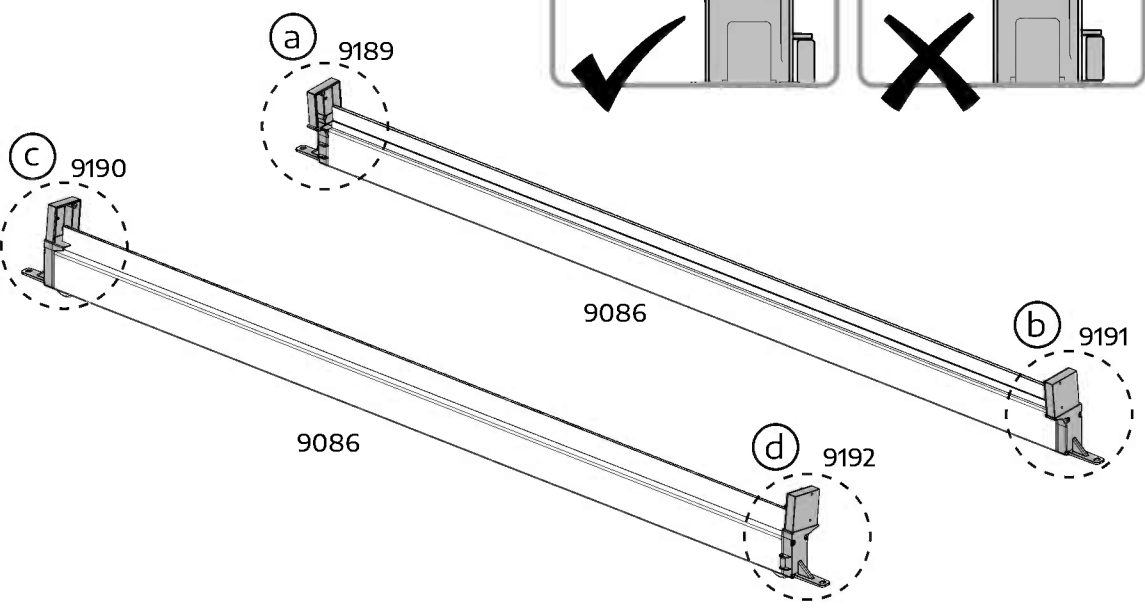
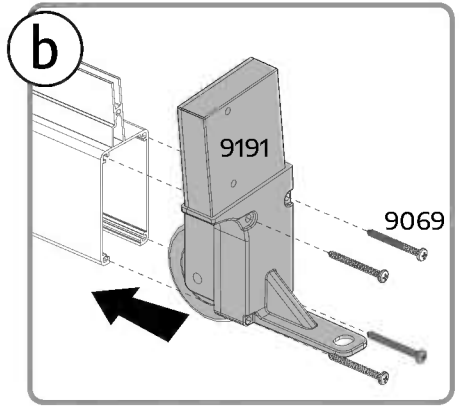
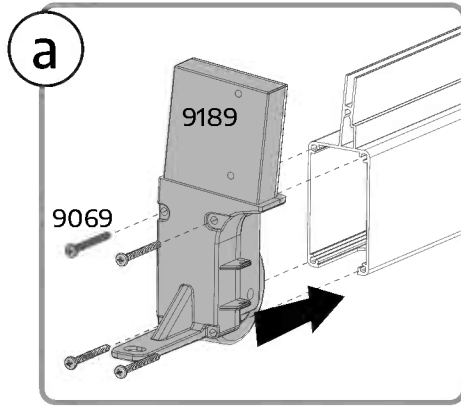
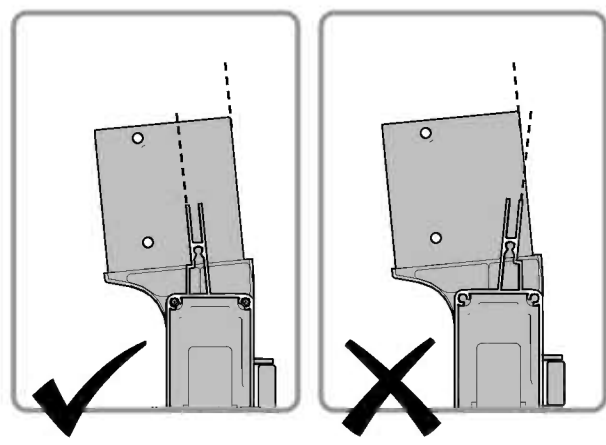

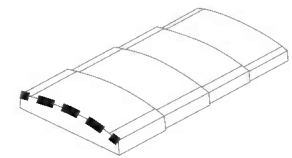

9057 1 9185 1 9066 2

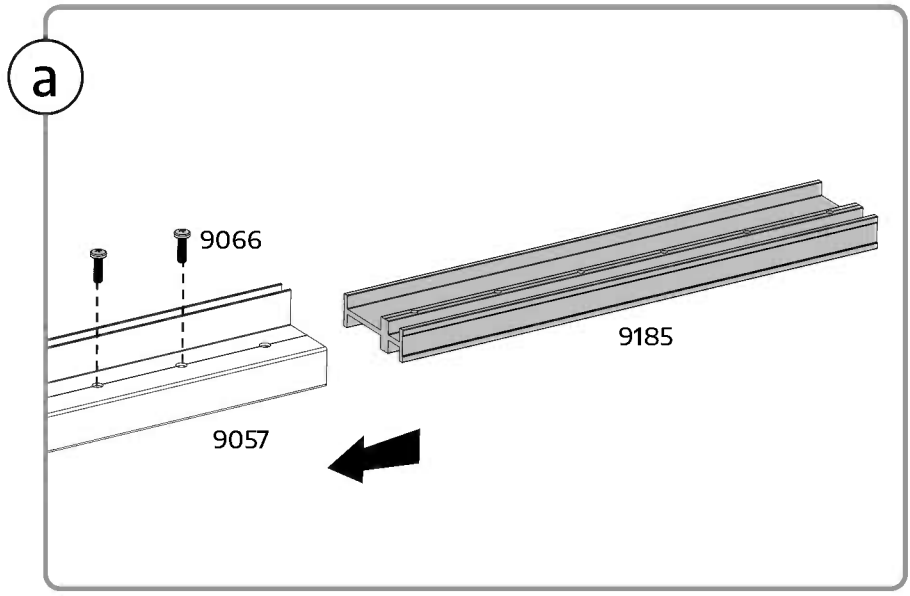
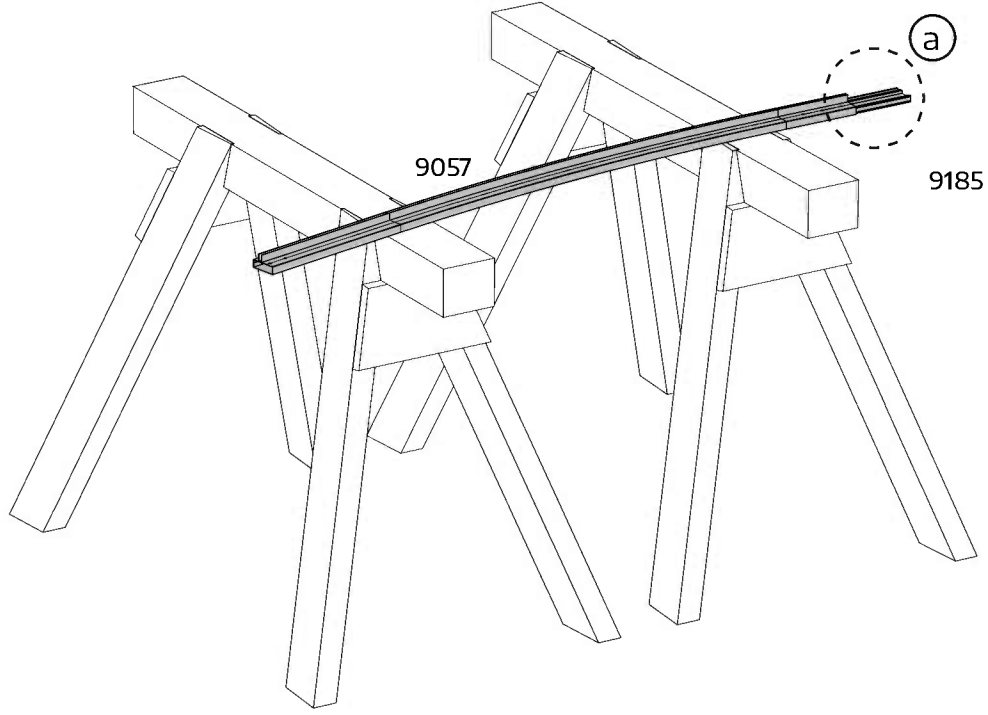
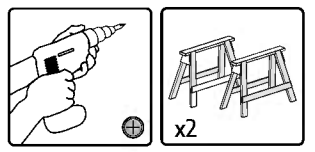

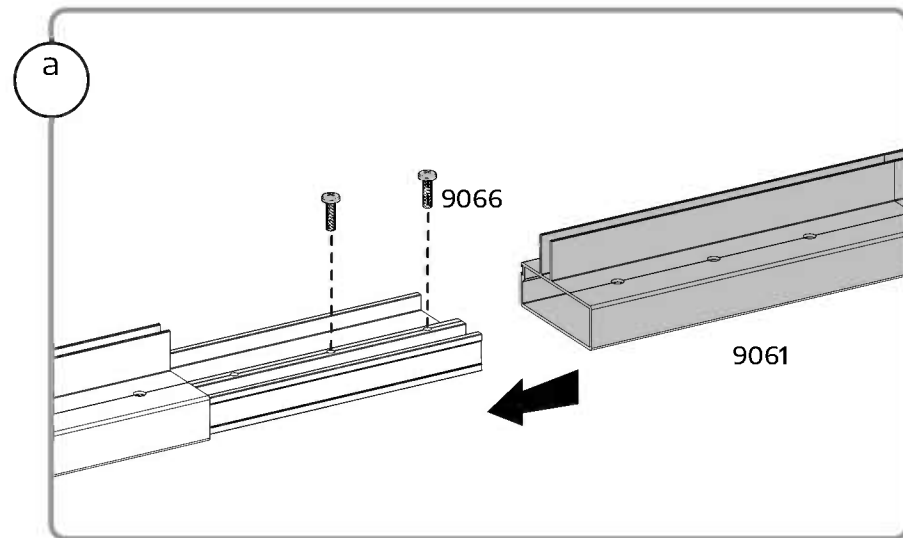
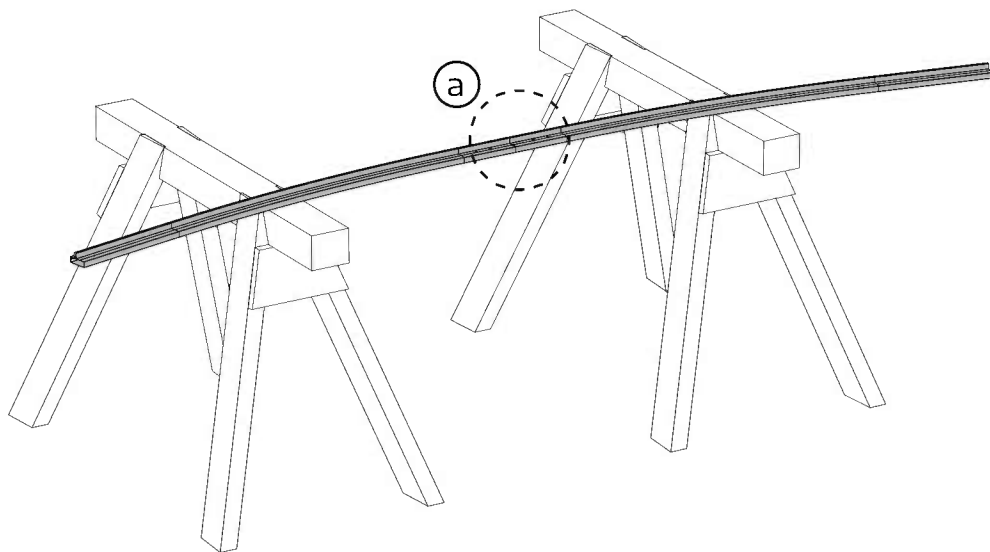
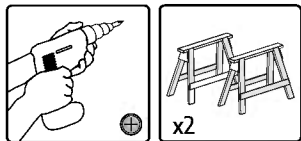
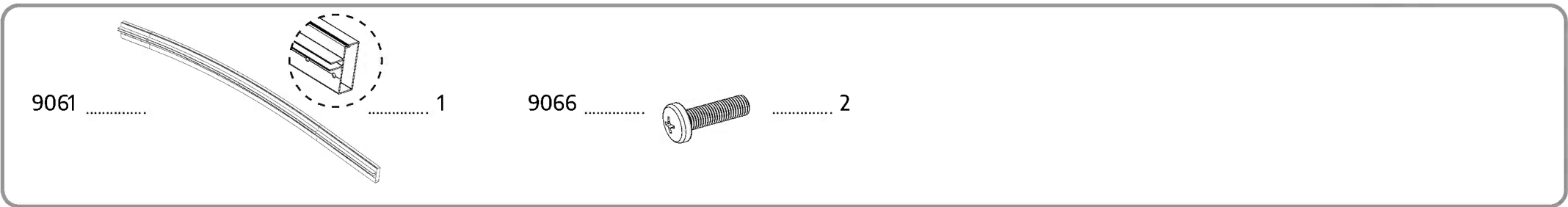
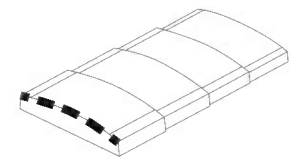

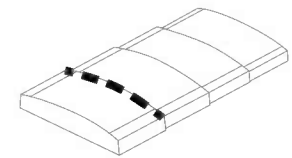

9073 1 9185 1 9066 2

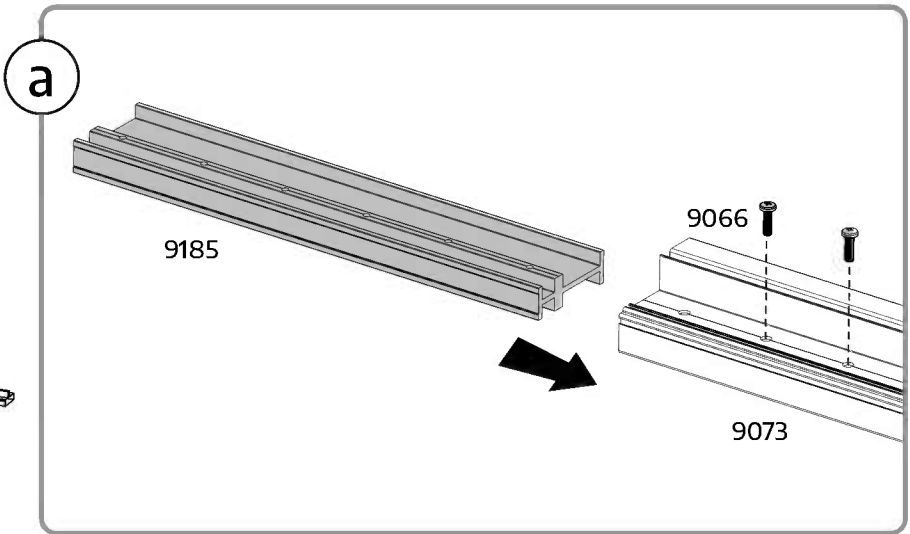
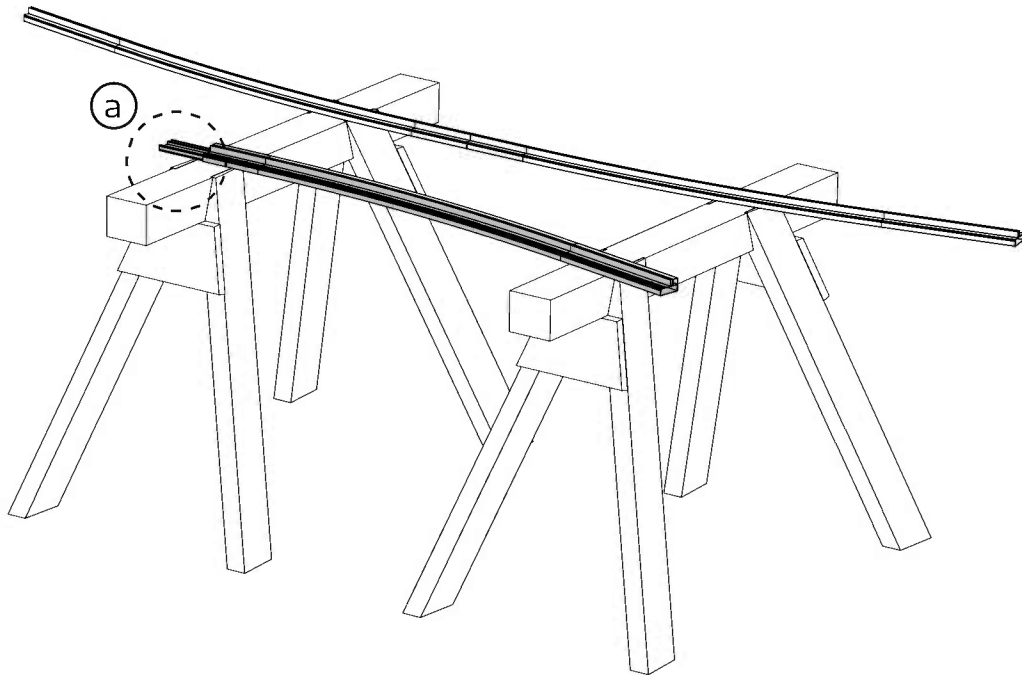
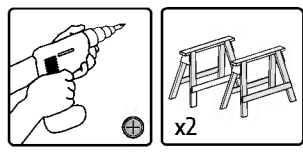

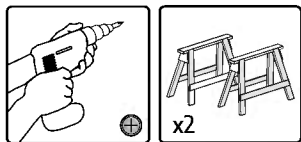
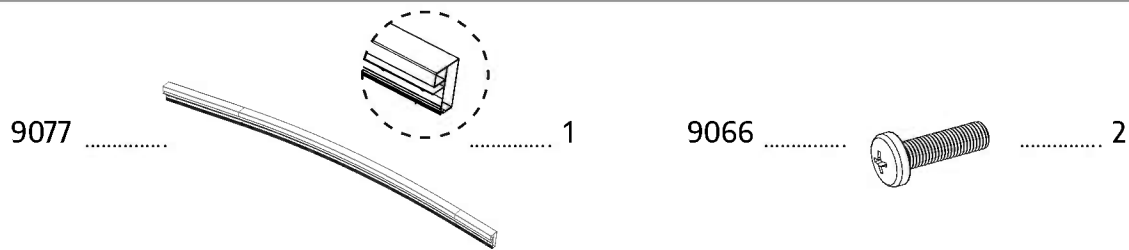
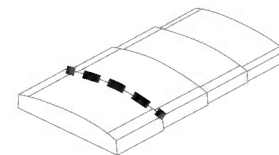

x2

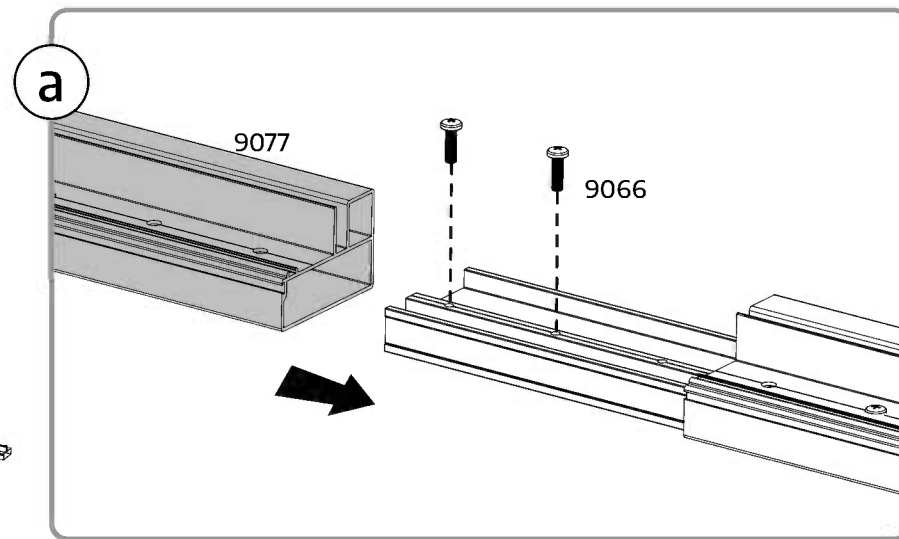
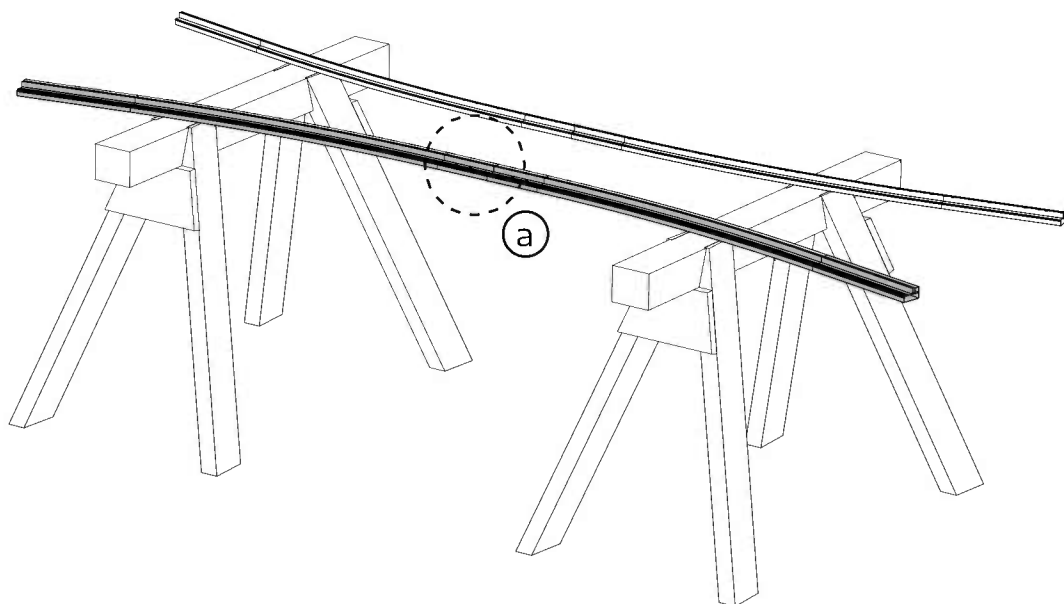

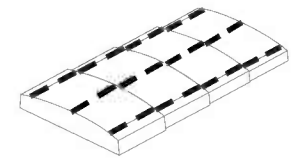

9053 12 9183 24 9082 48

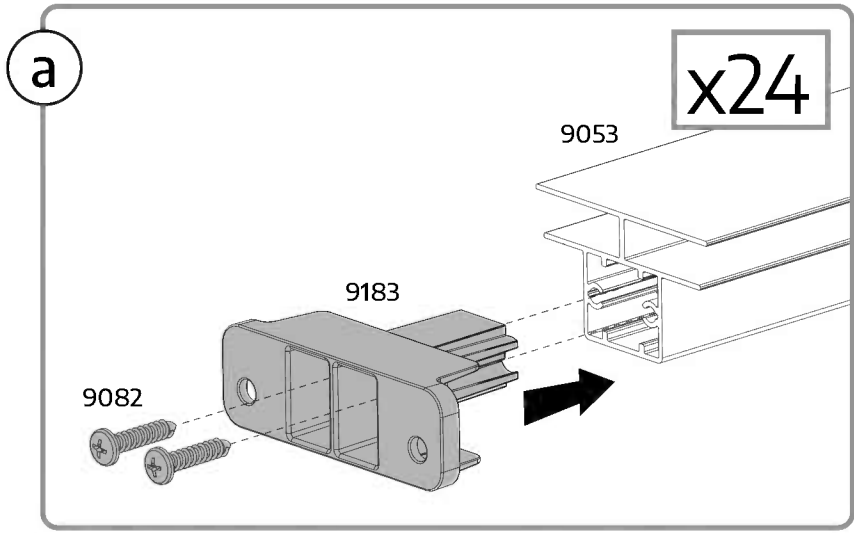
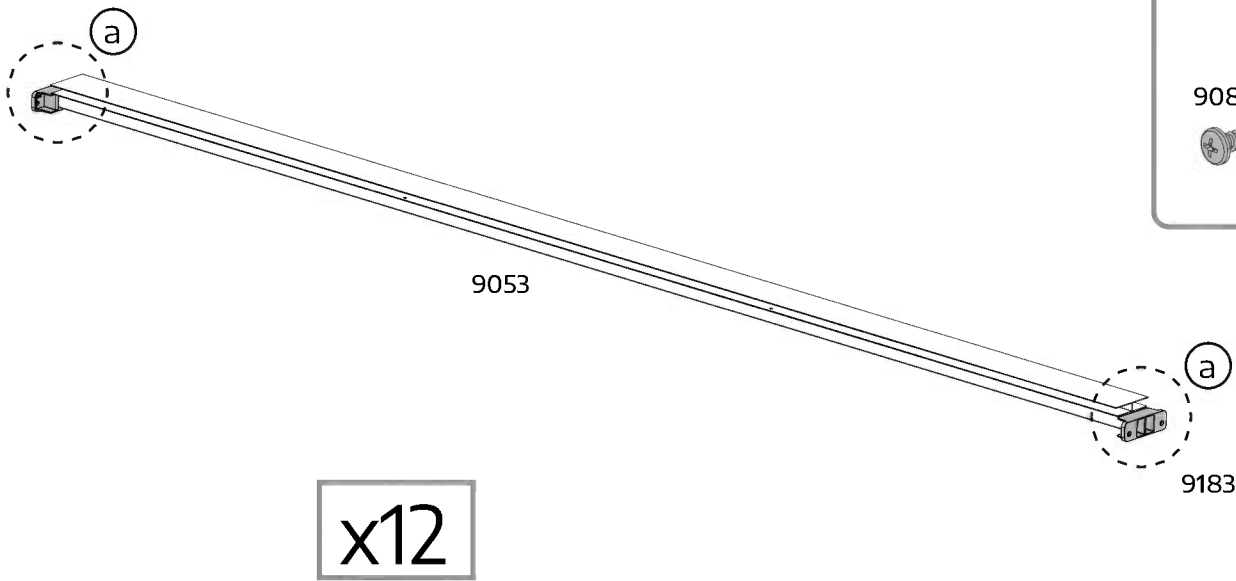
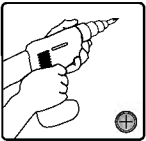

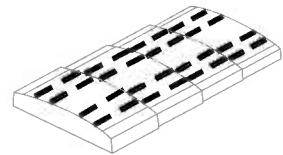

9052 16 9183 32 9082 64

a

9052

9183

x12

a

9082

9183

9052

x32

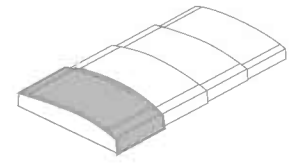

9066 4

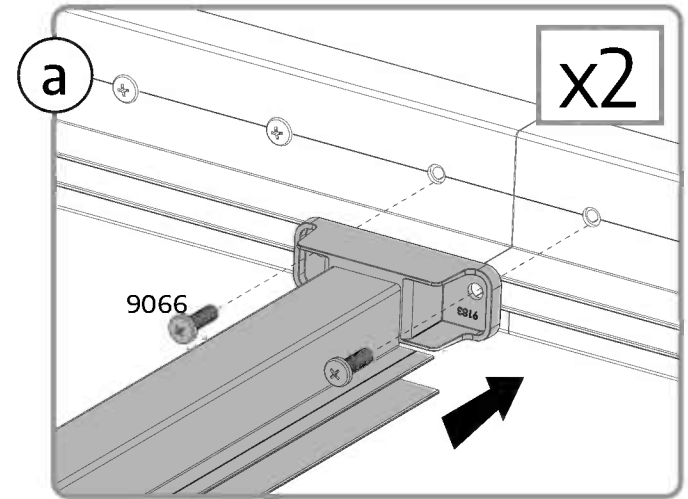
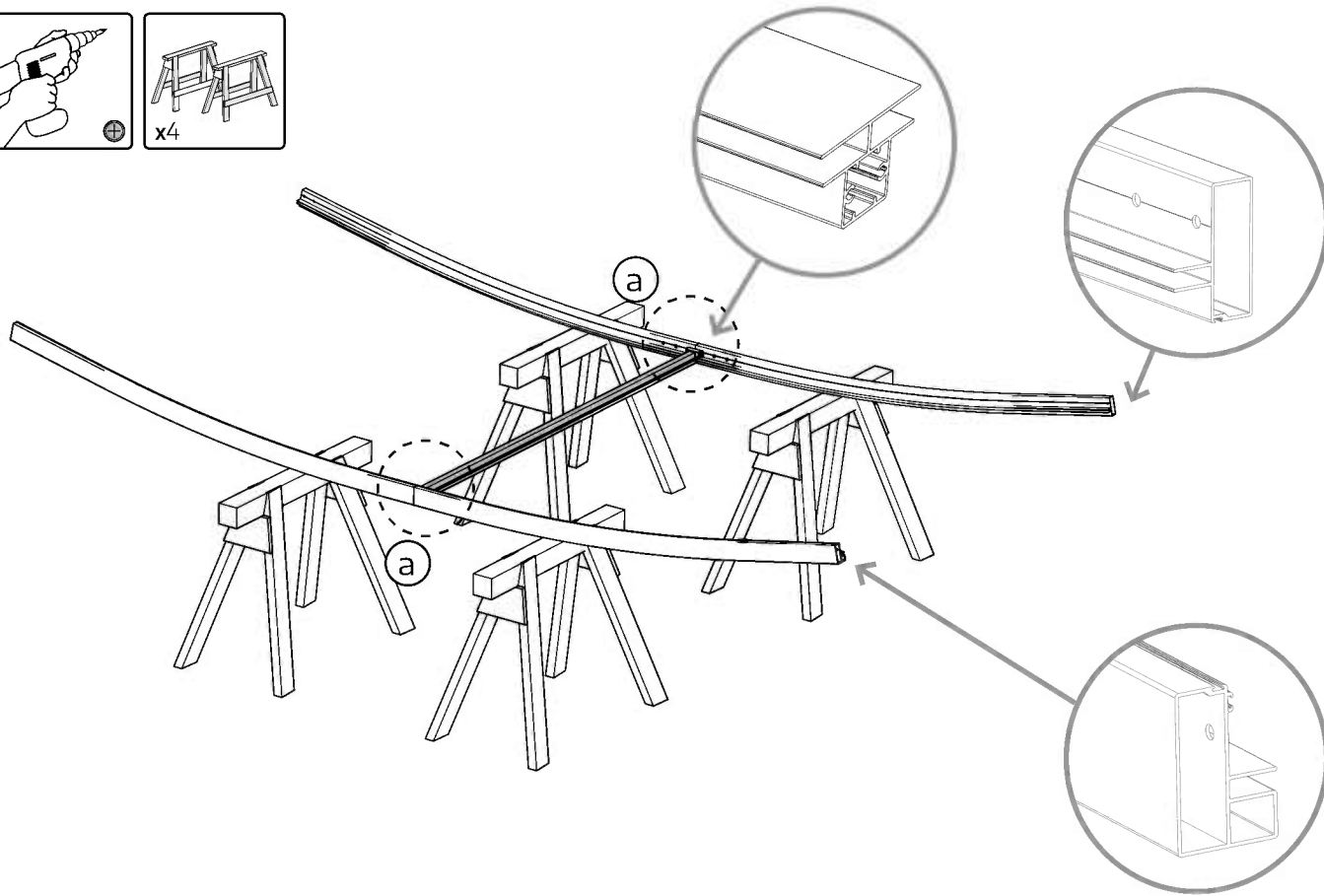
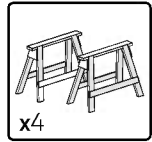
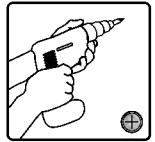
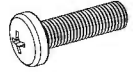

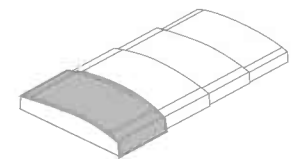

9082 16

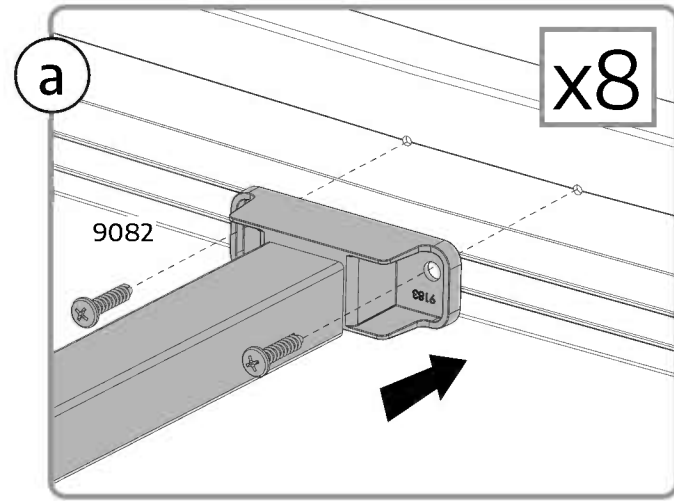
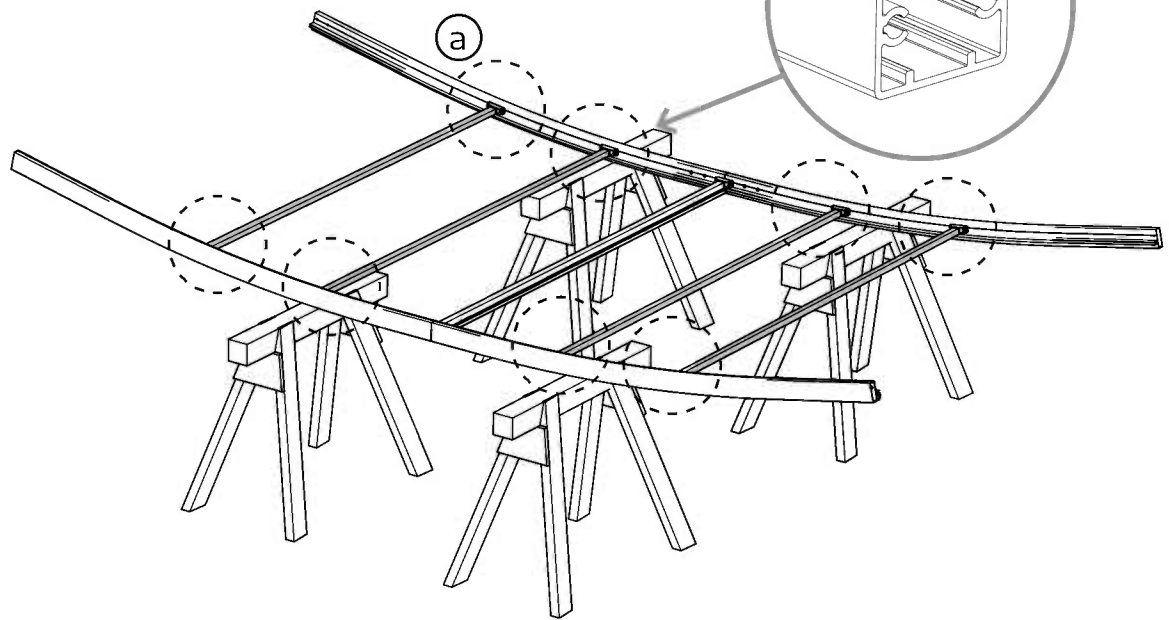
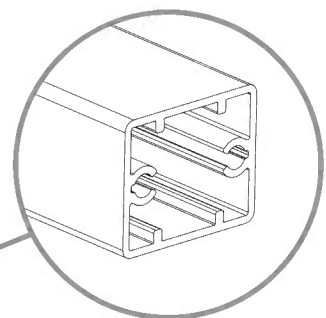
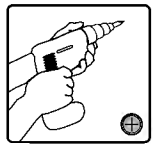
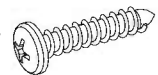

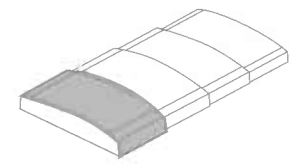

9051 4 9083 4

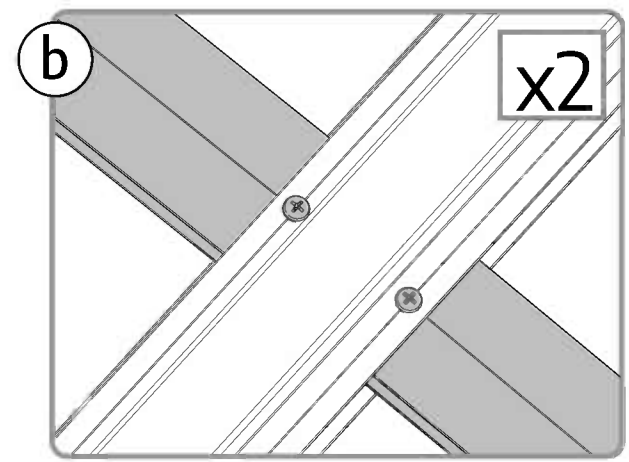
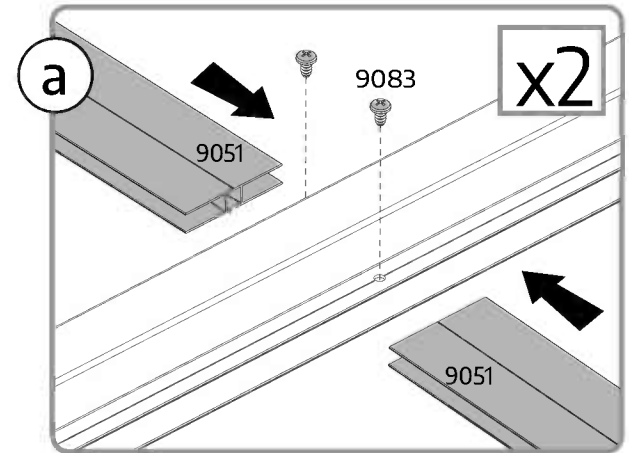
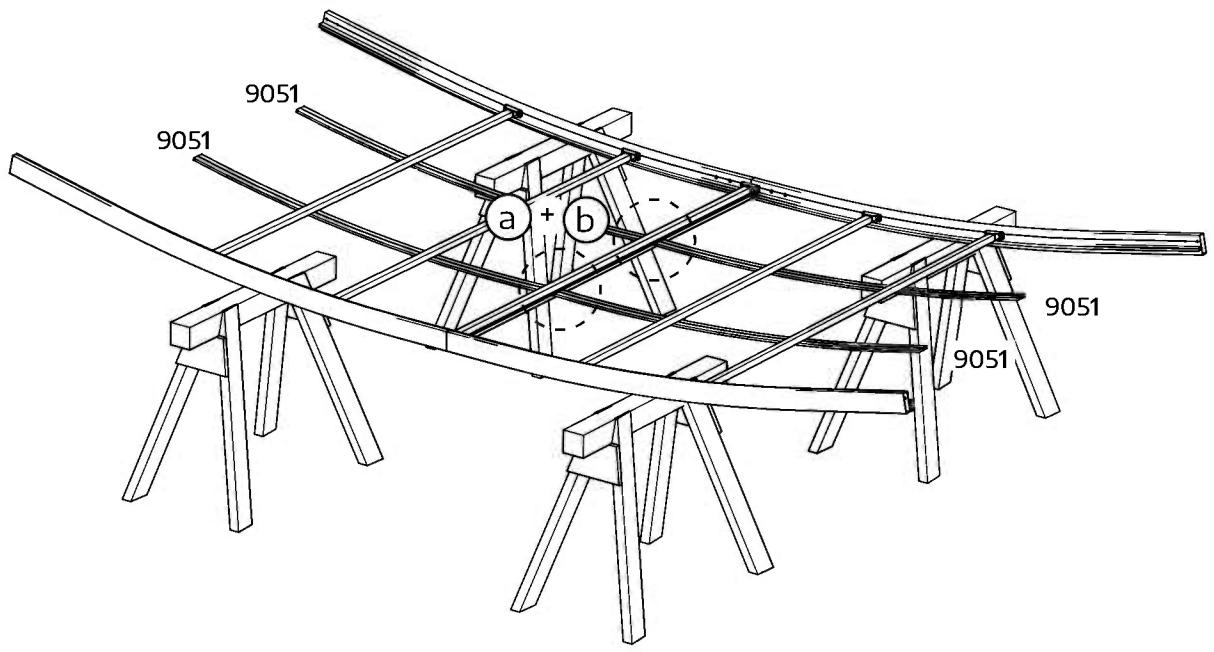
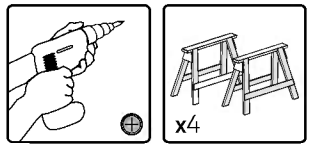

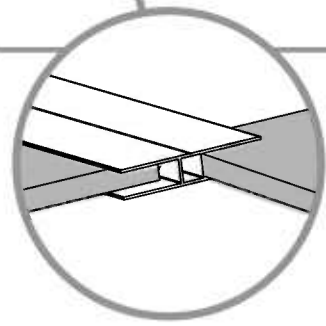
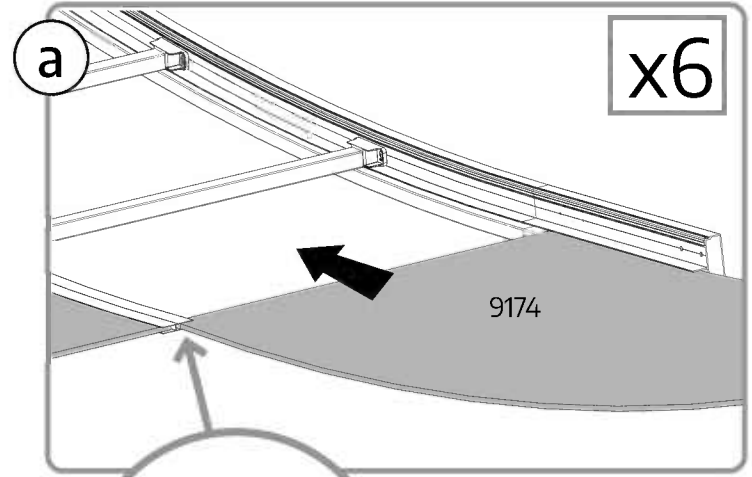
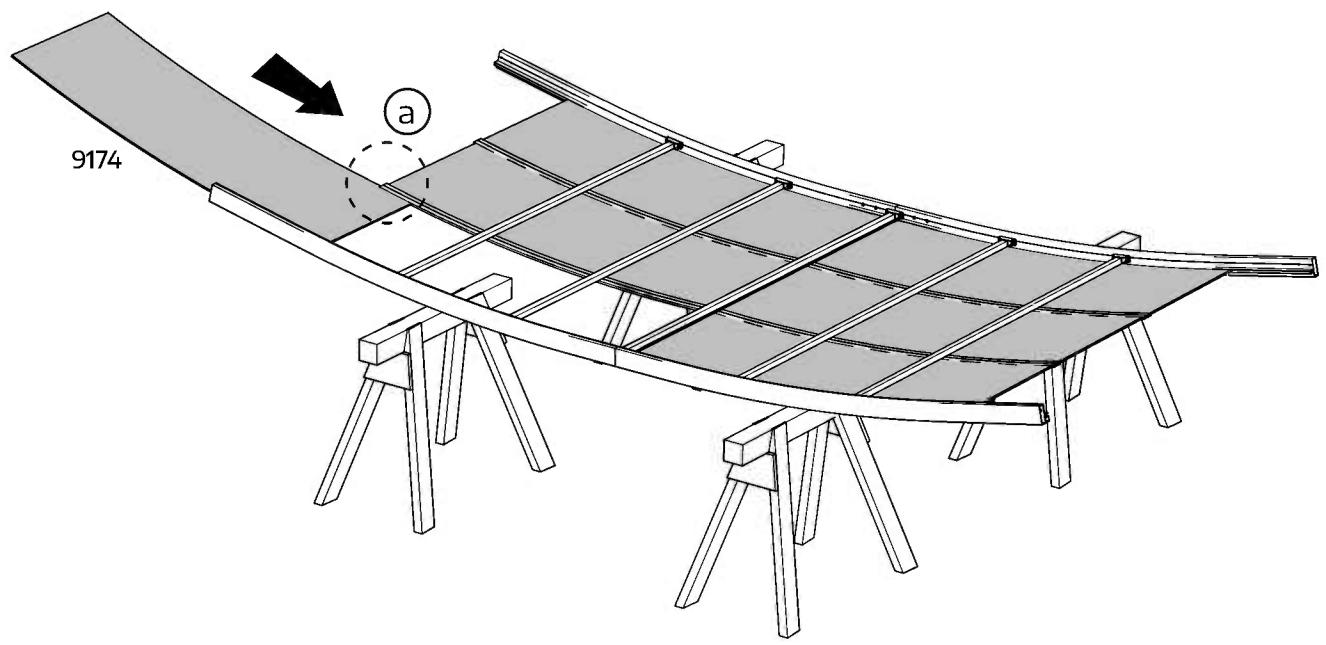
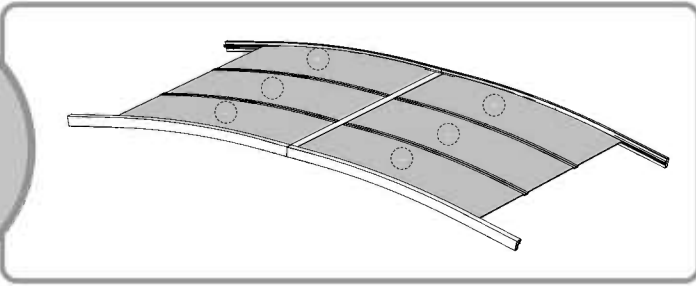
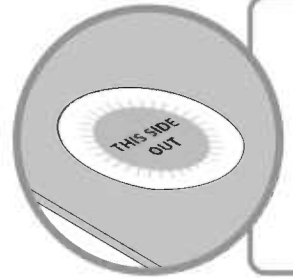
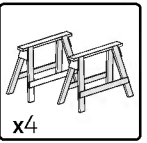
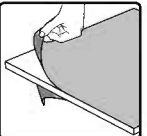
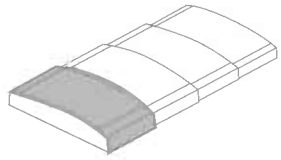

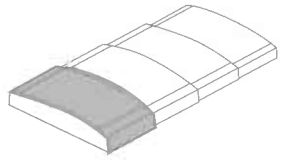

9082 8

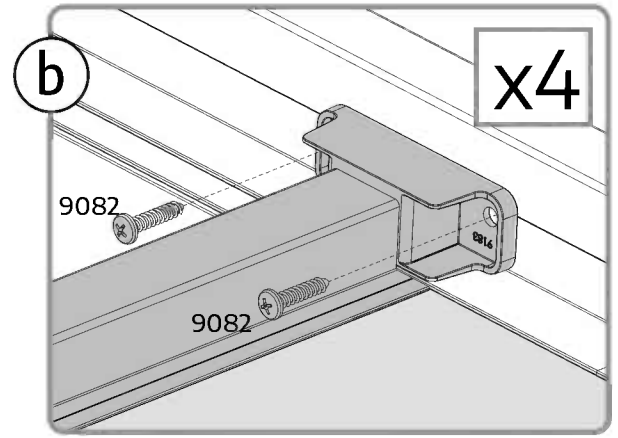
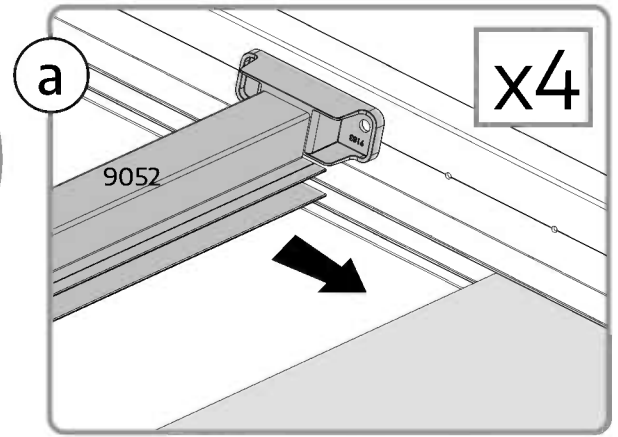
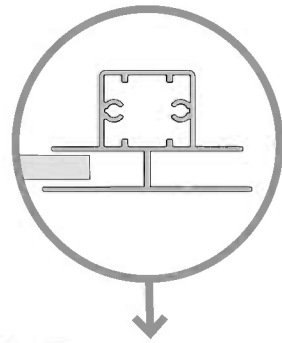
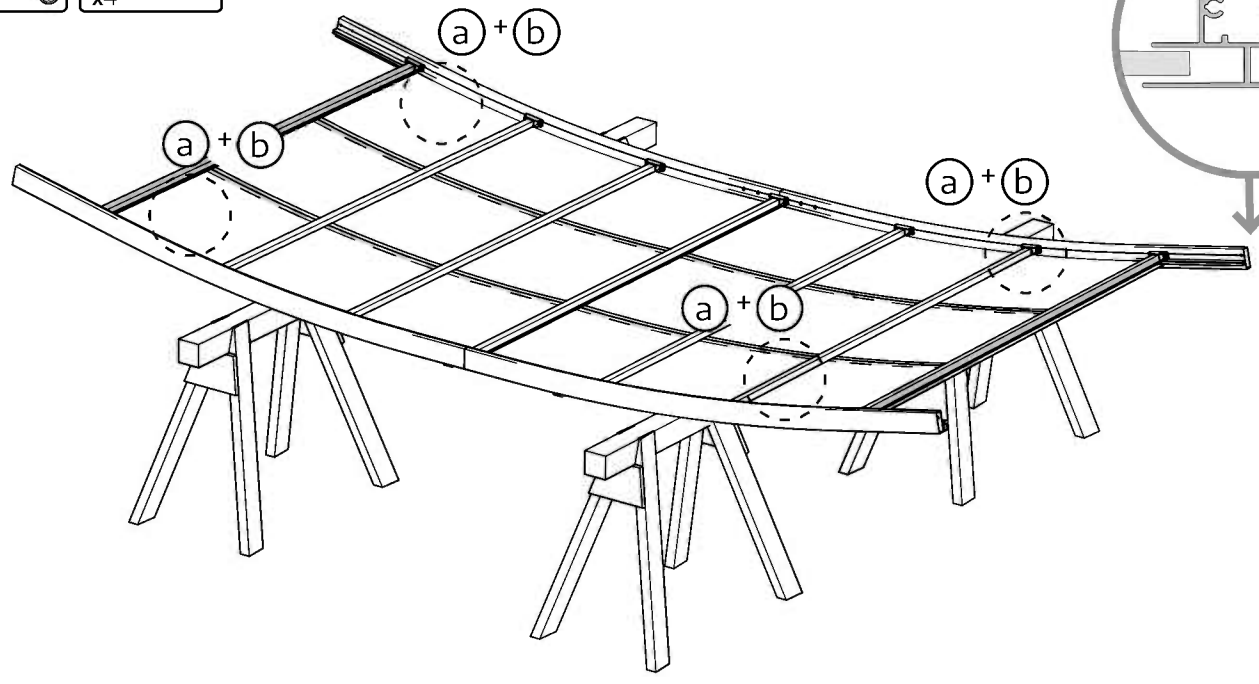
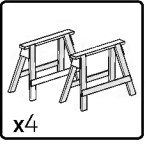
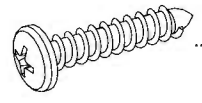

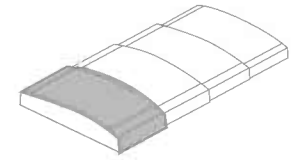

9083 4

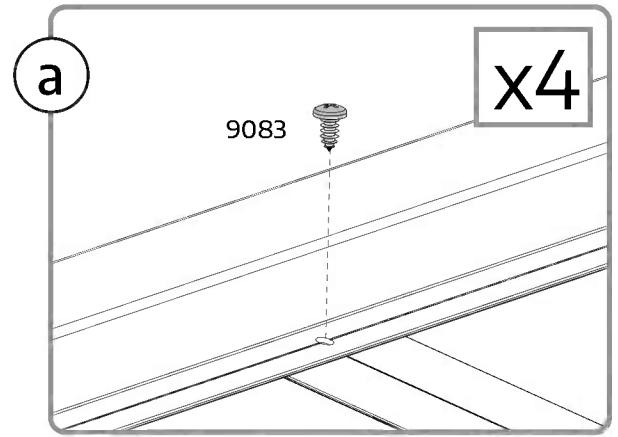
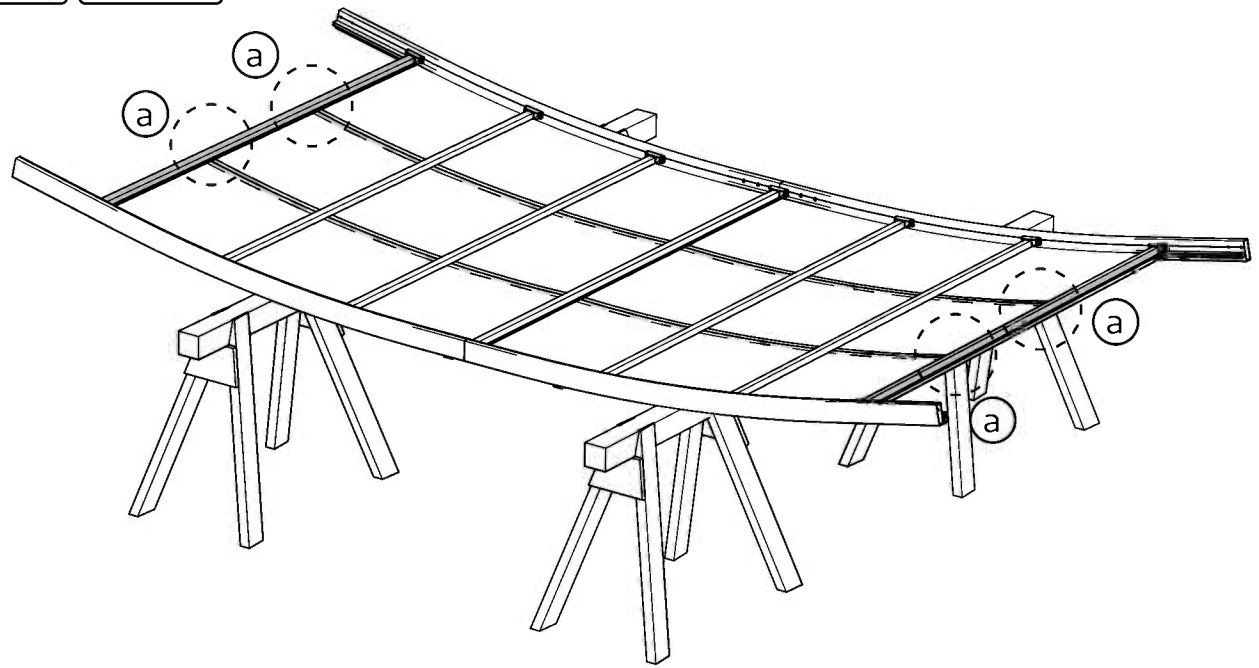
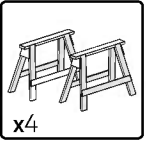
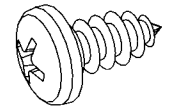

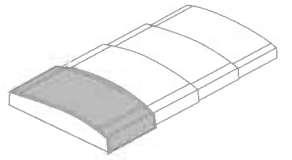

9178 2

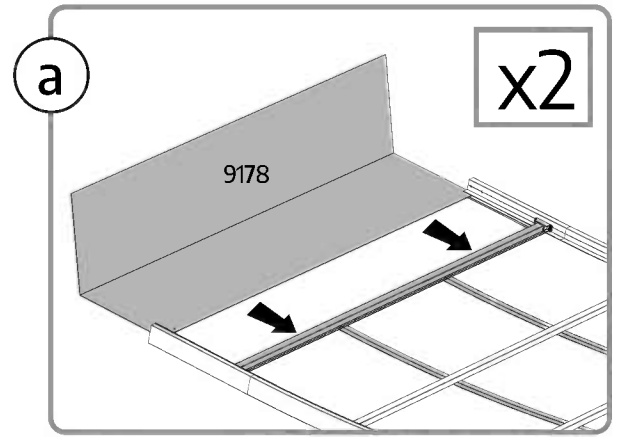
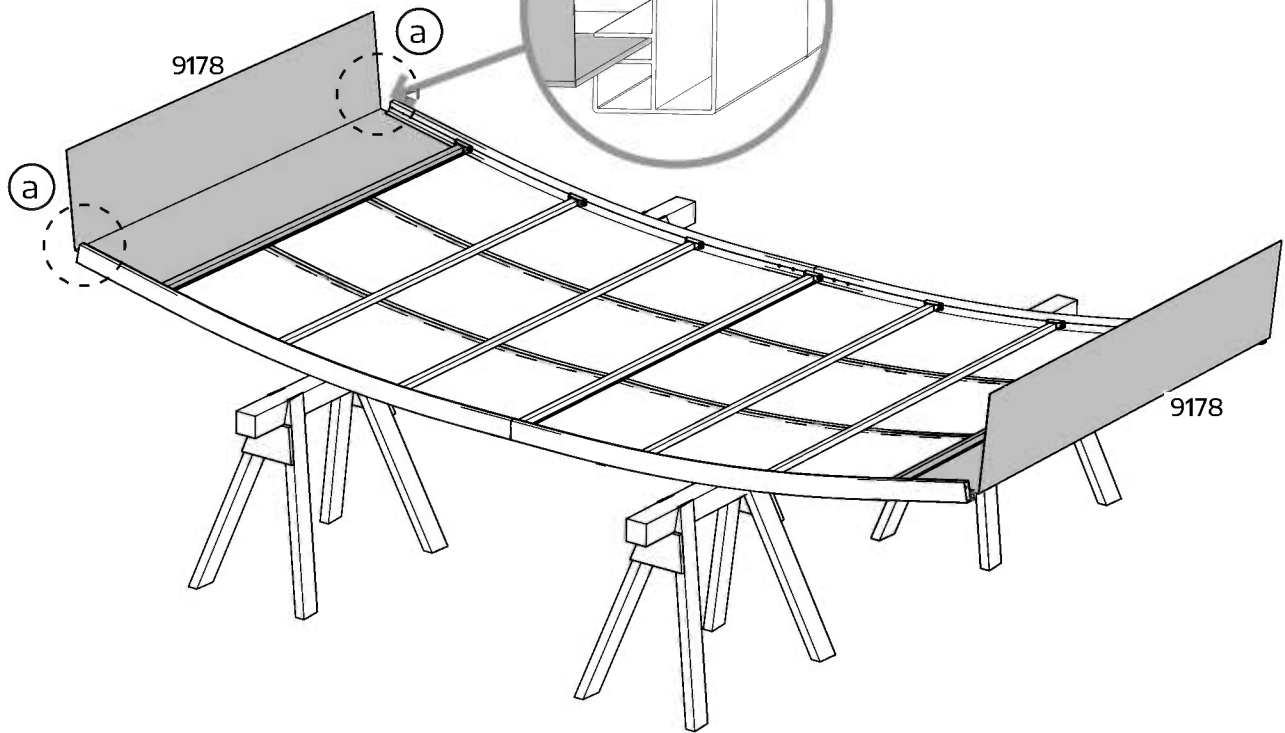
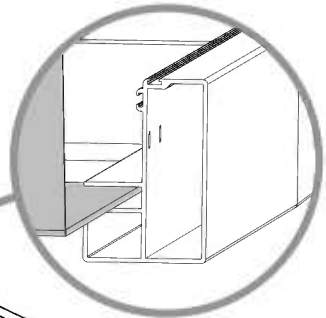
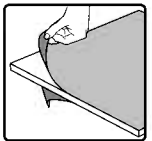
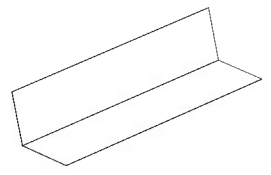

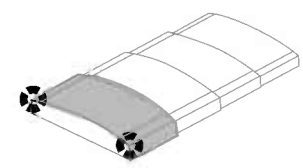

9186 2 9188 2 9067 4

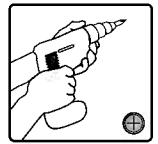

x2

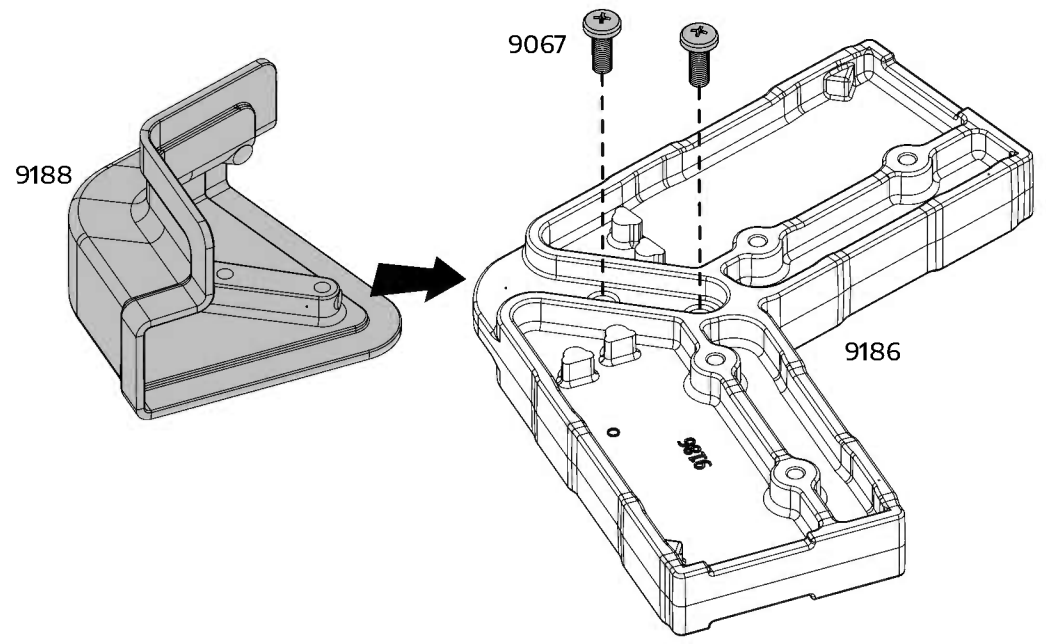

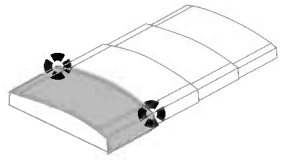

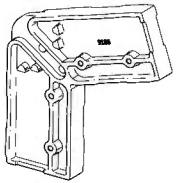
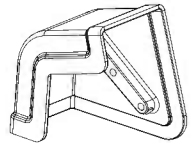
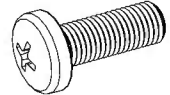
- 9186 2 9187 2 9067 4
- 
- 
- 

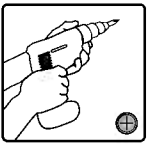

x2

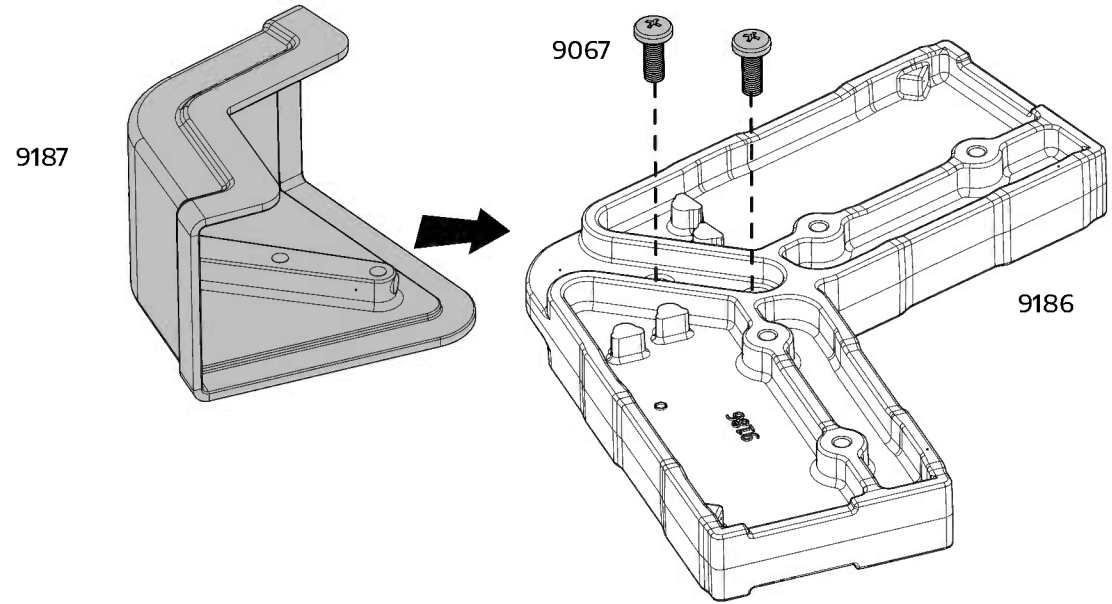

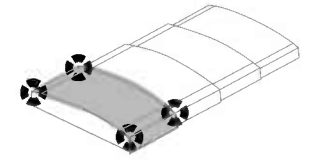

9066 8

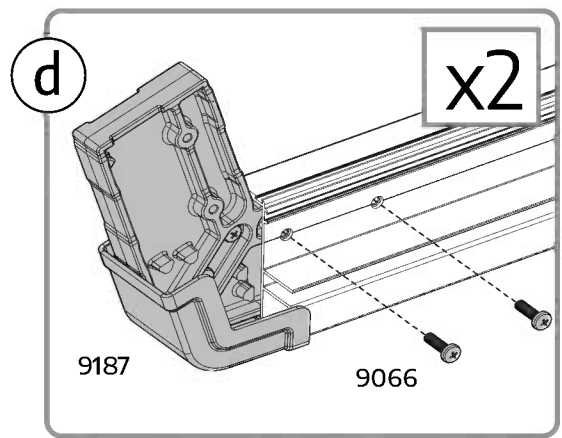
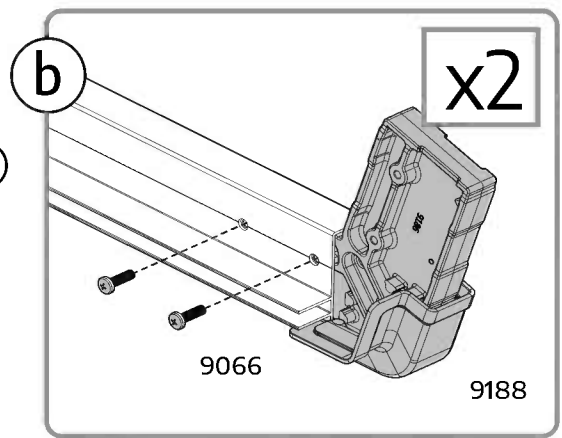
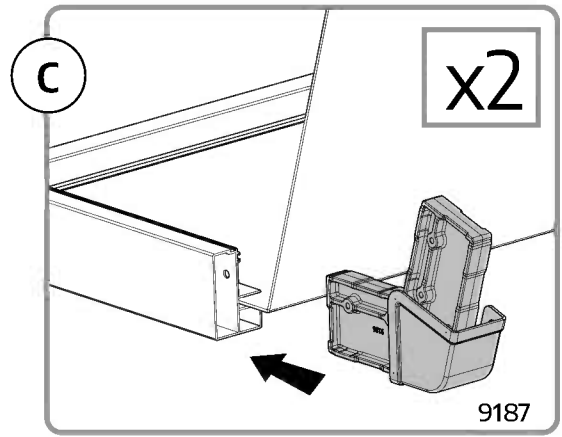
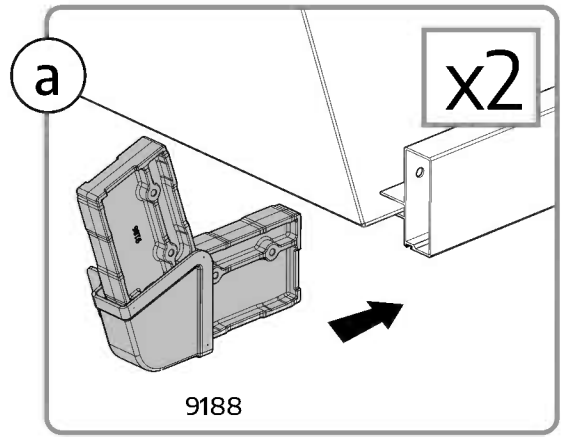
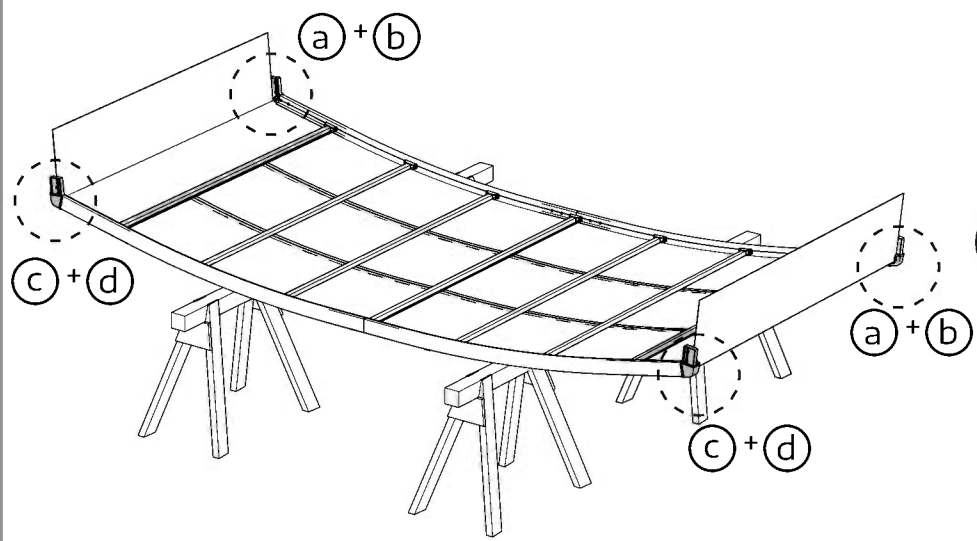
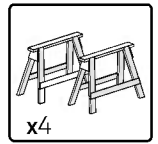
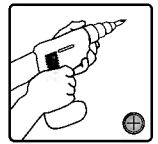
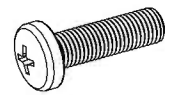

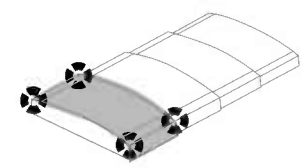

- 9065 2 9081 2 9066 8
-

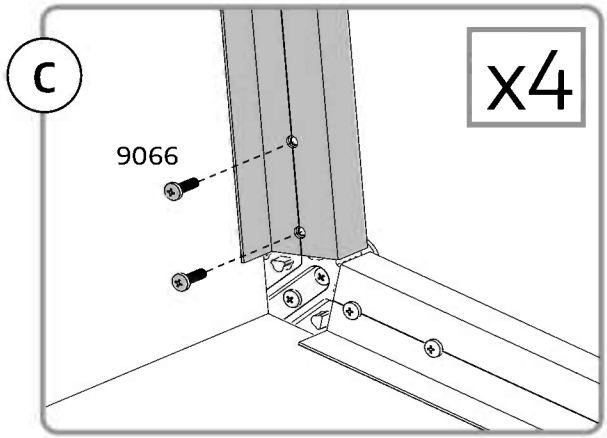
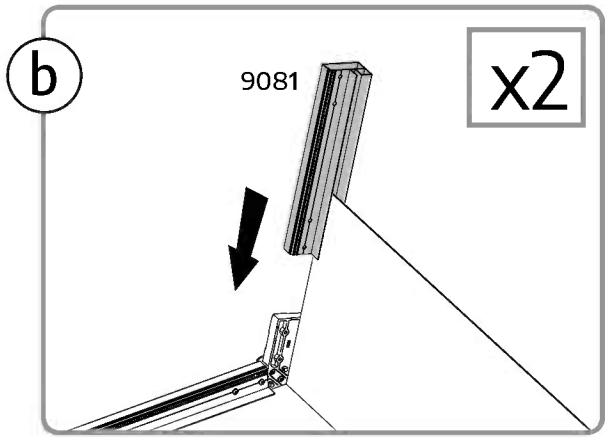
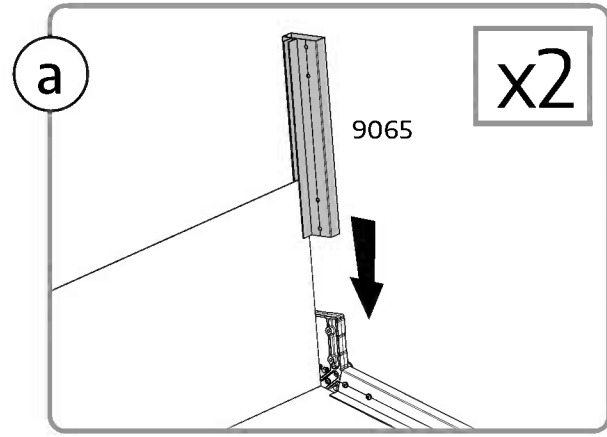
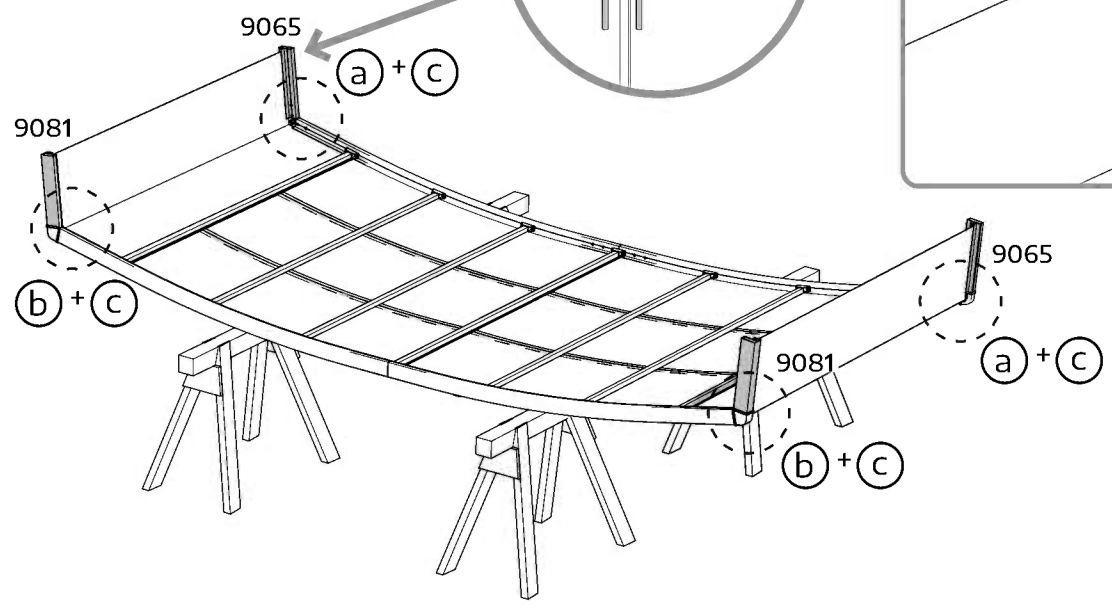
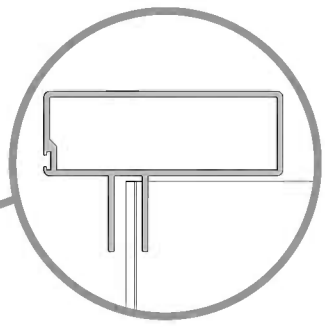
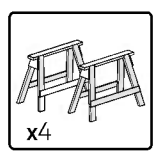
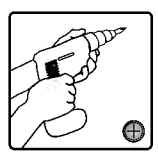

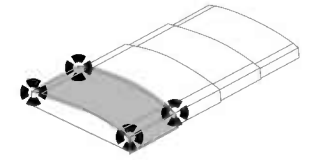

9066 8

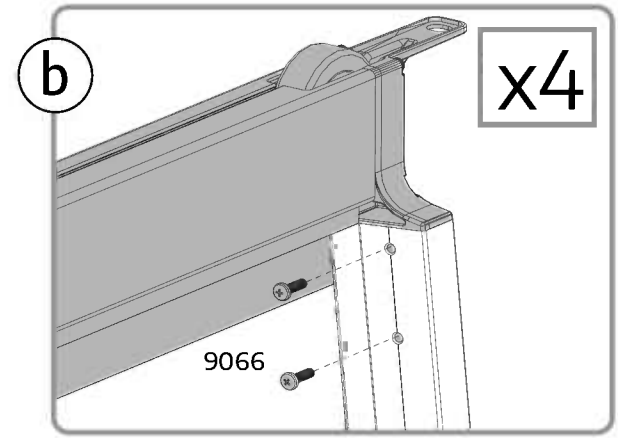
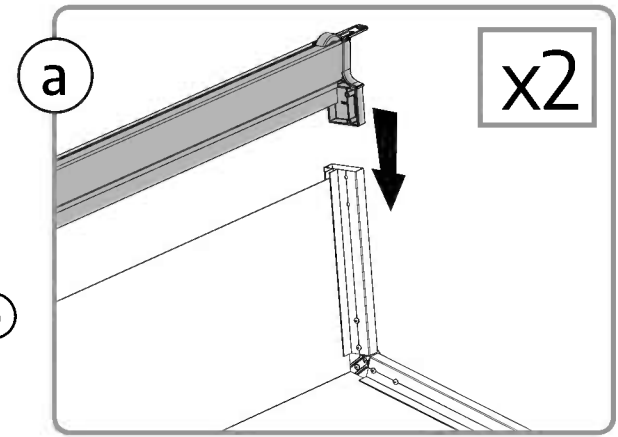
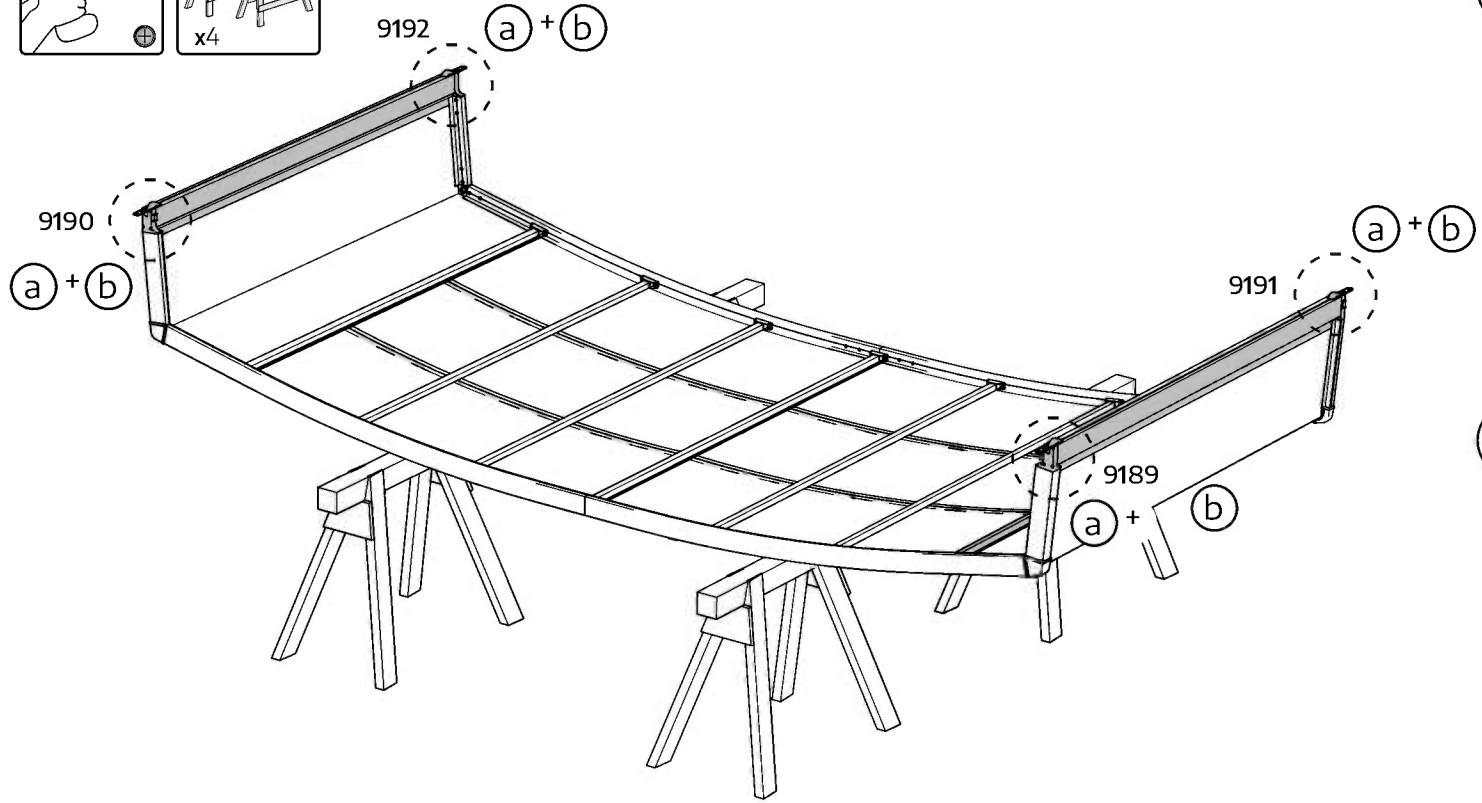
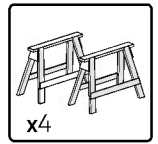
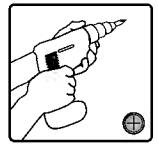
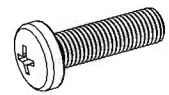

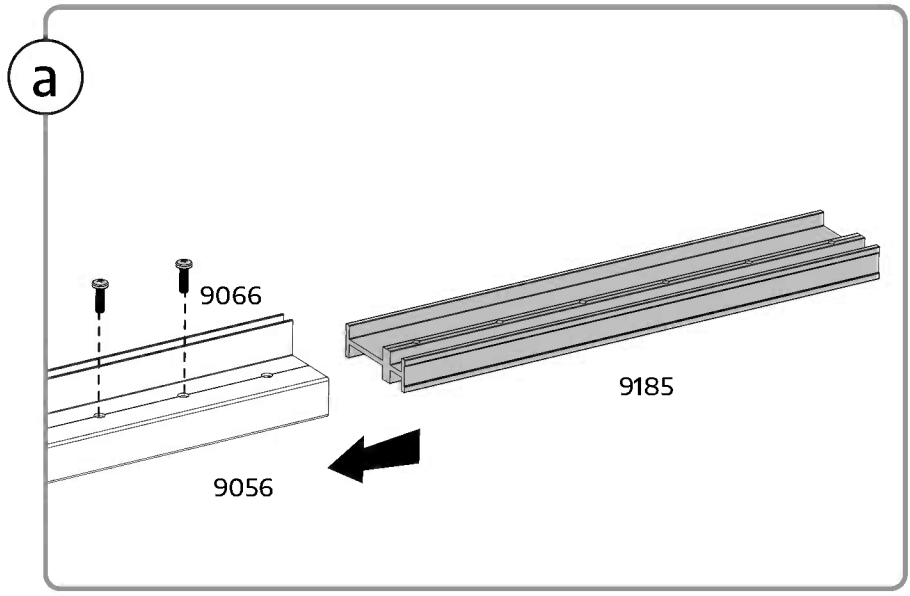
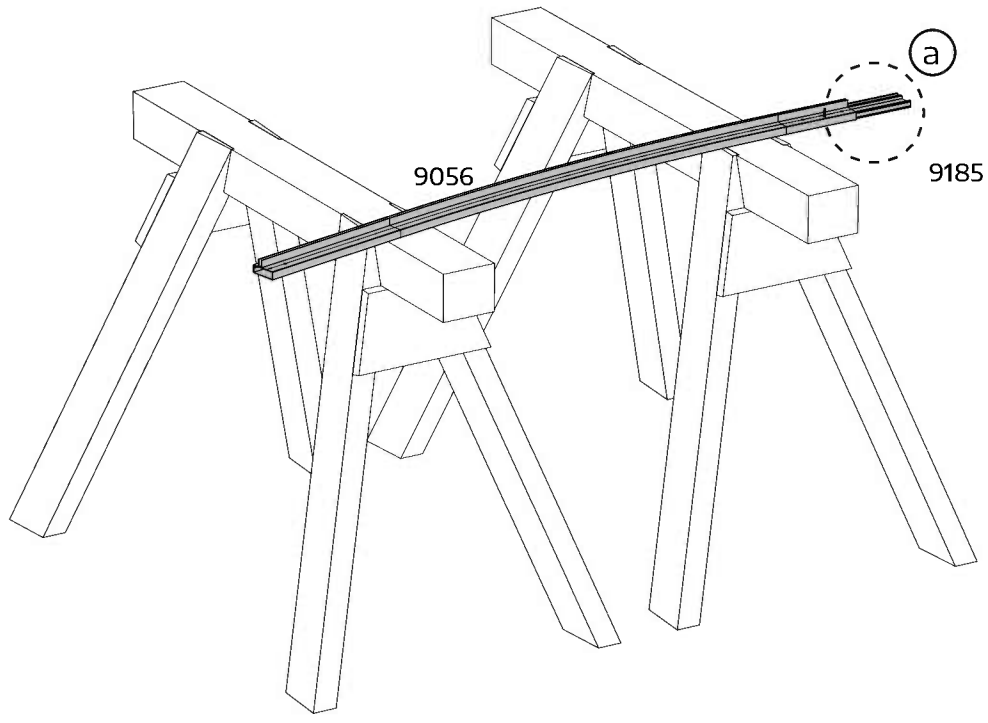
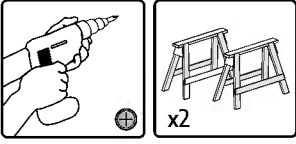
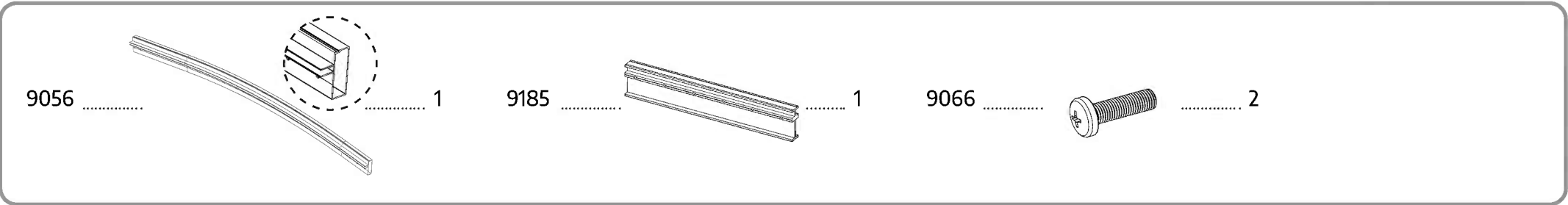
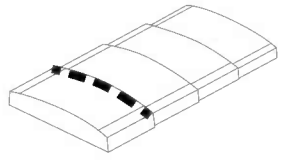

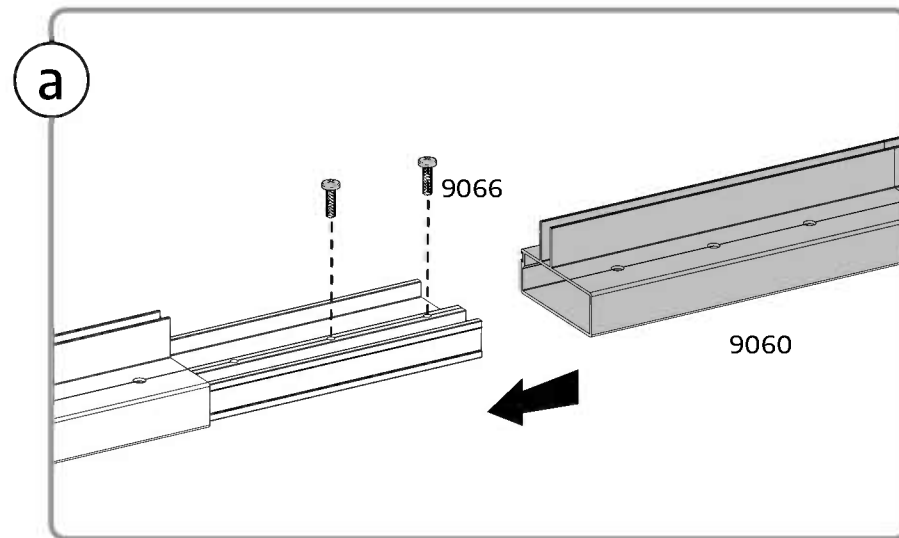
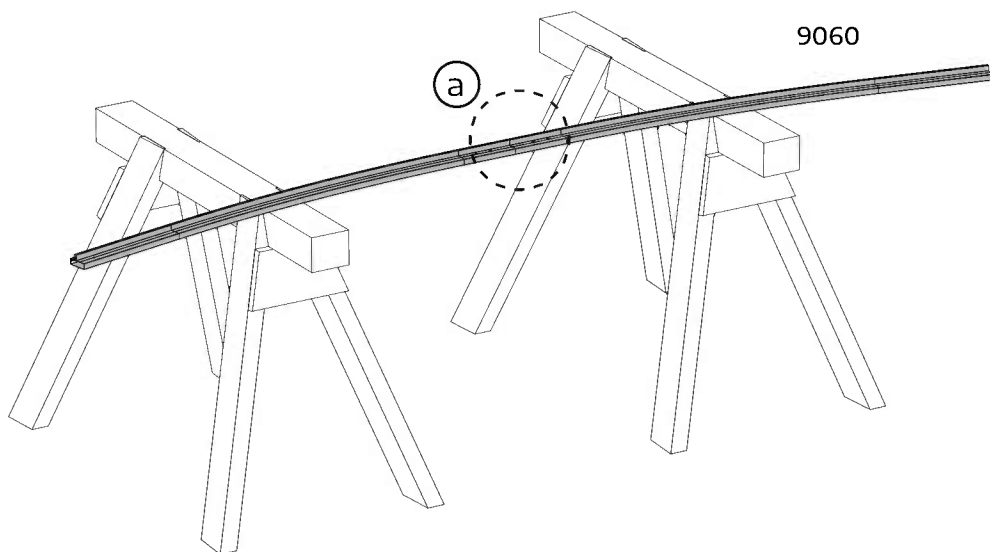
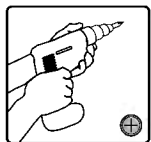
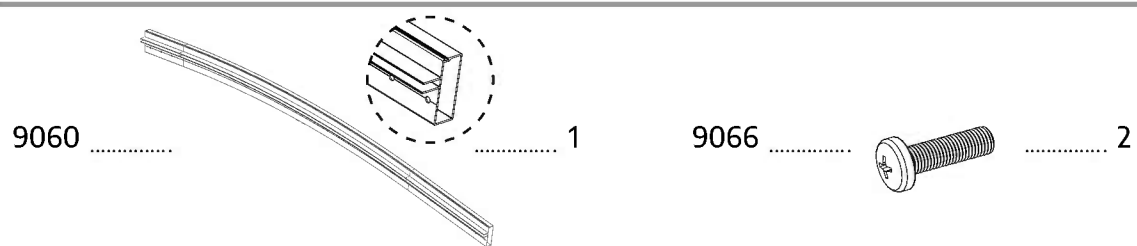
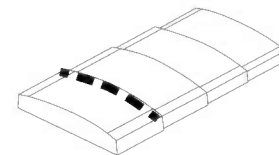

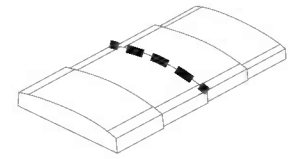

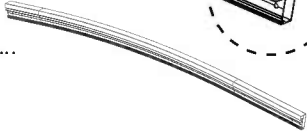
9072  1

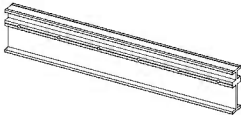
9185  1

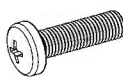
9066  2

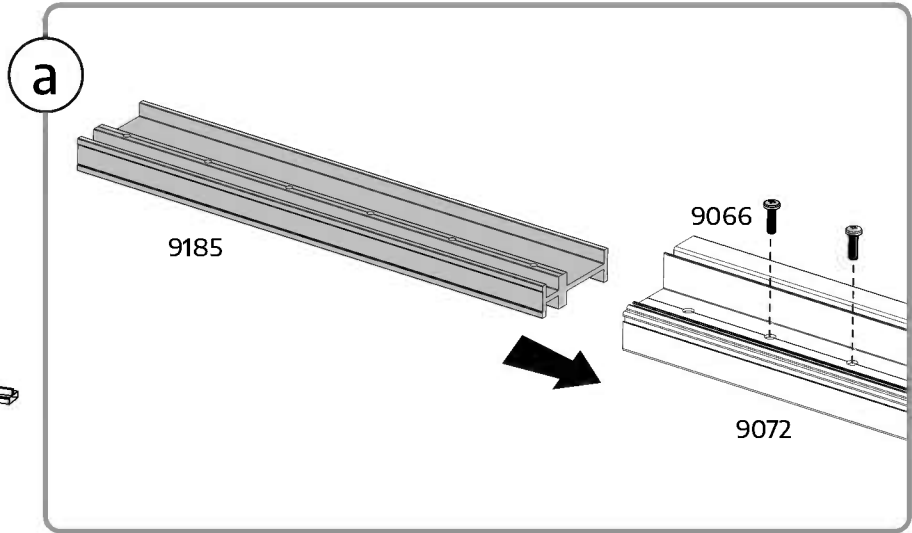
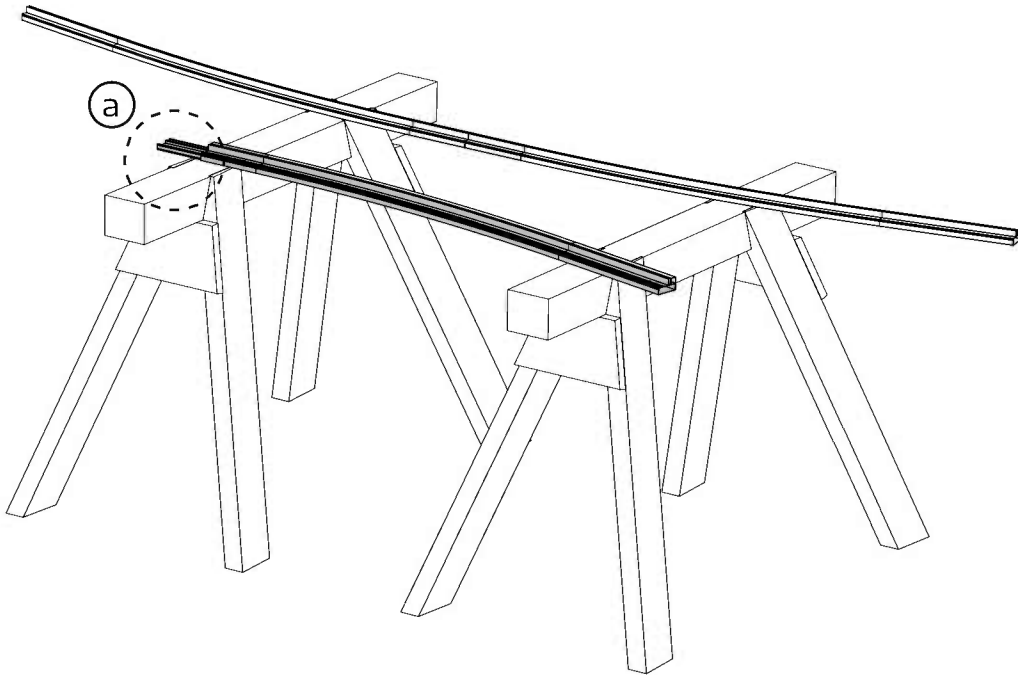
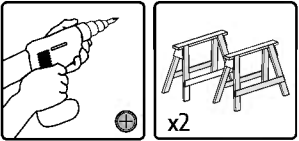

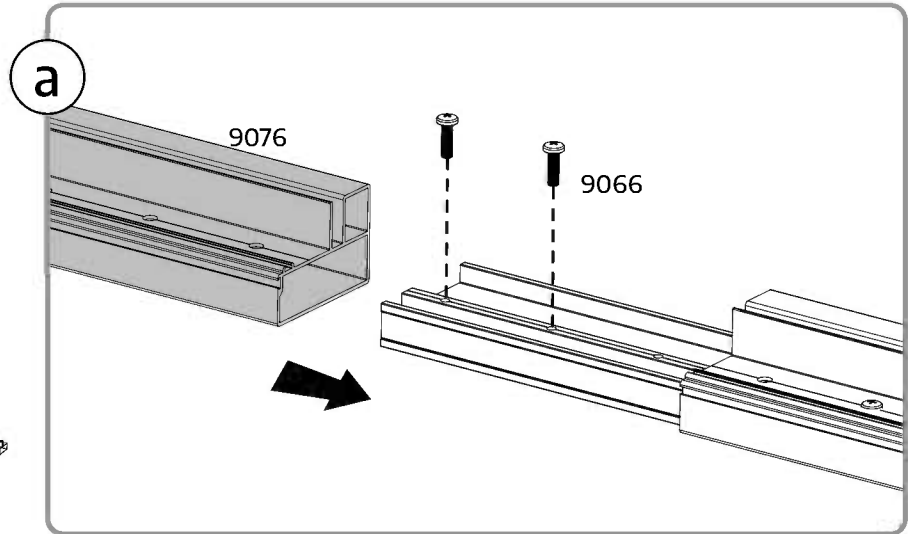
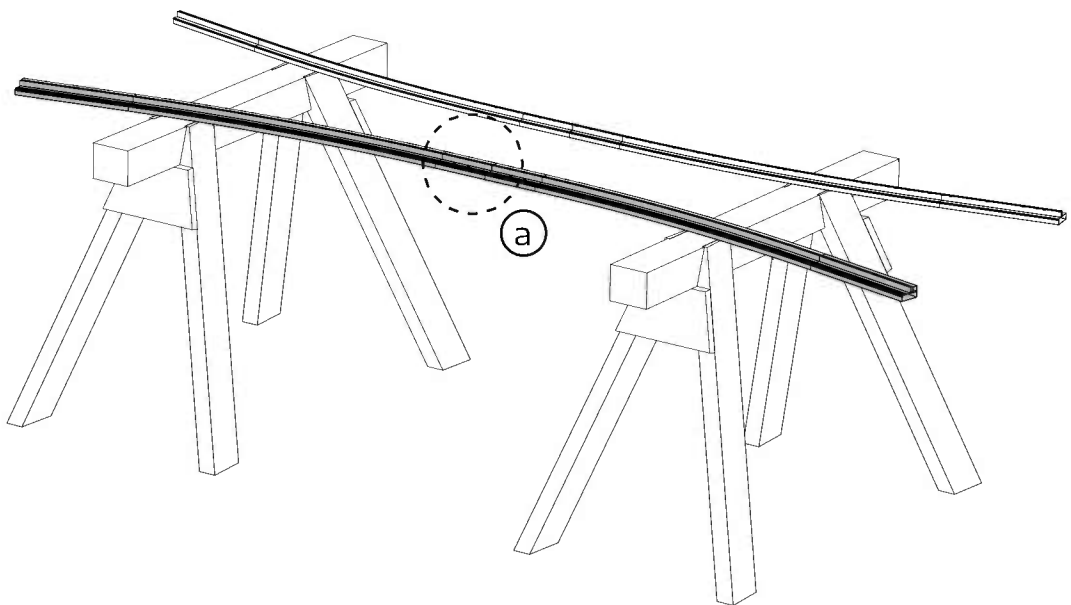
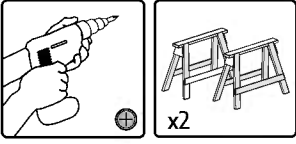
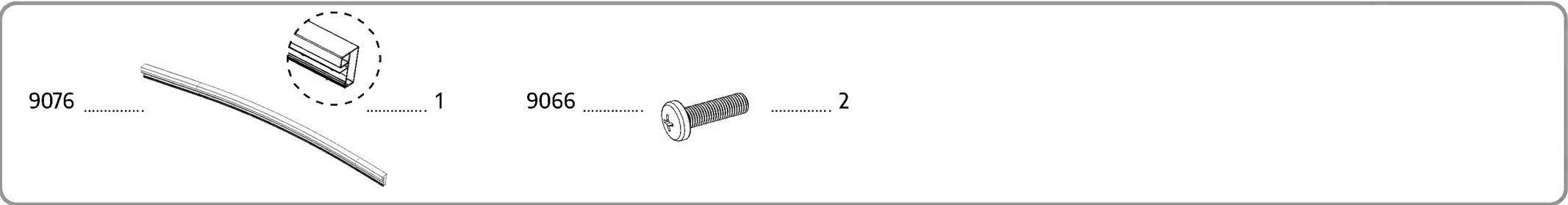
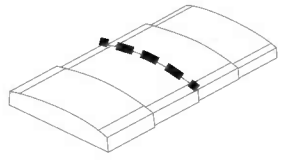

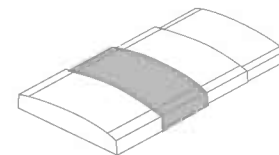

9066 4

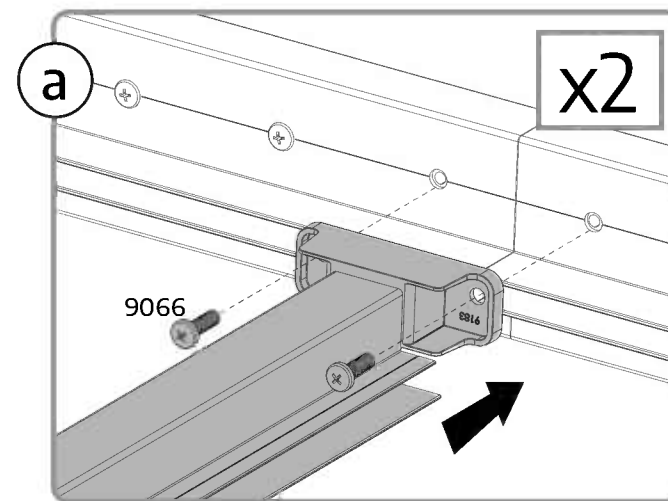
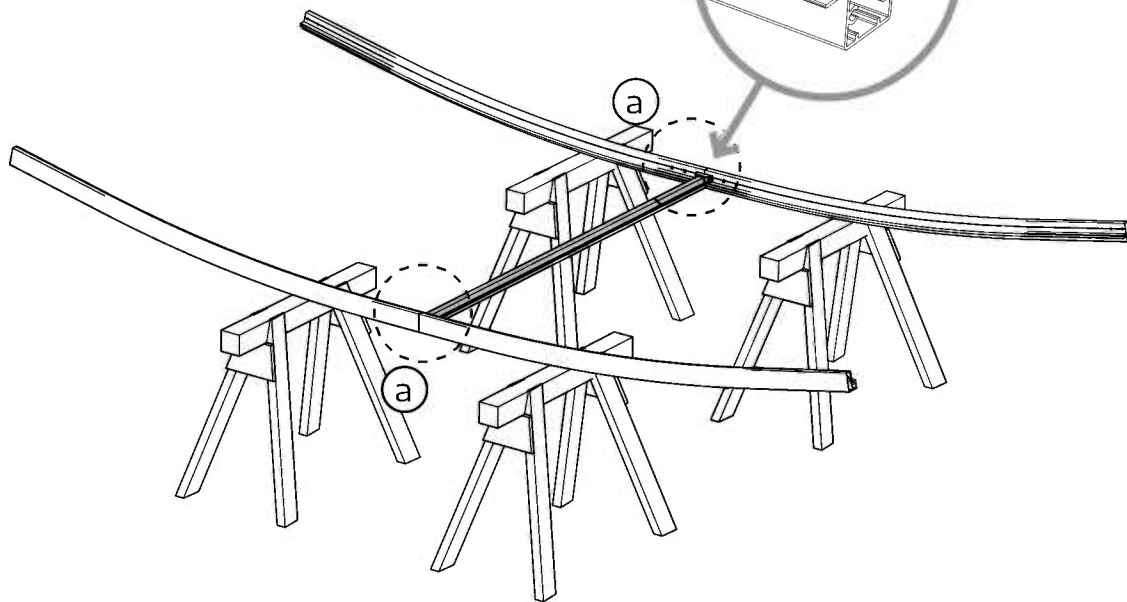
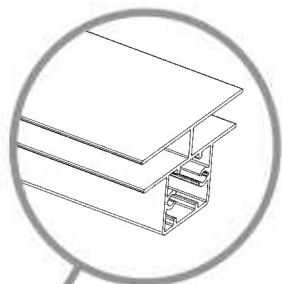
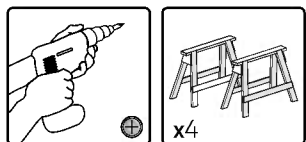
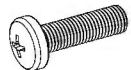

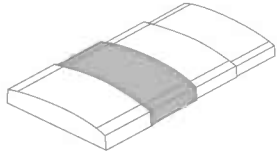

9082 16

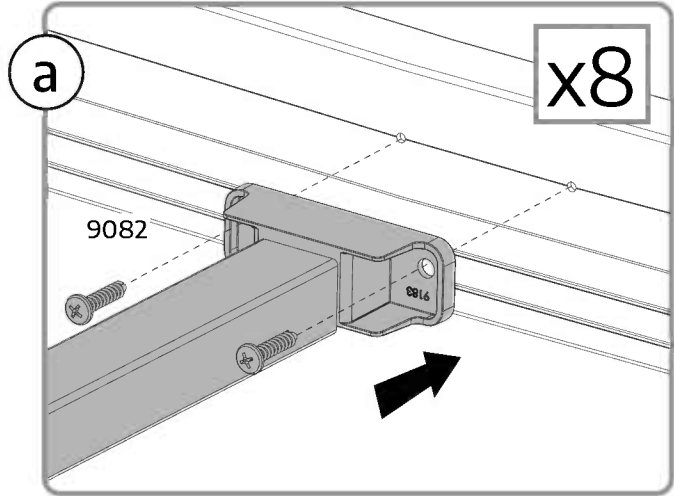
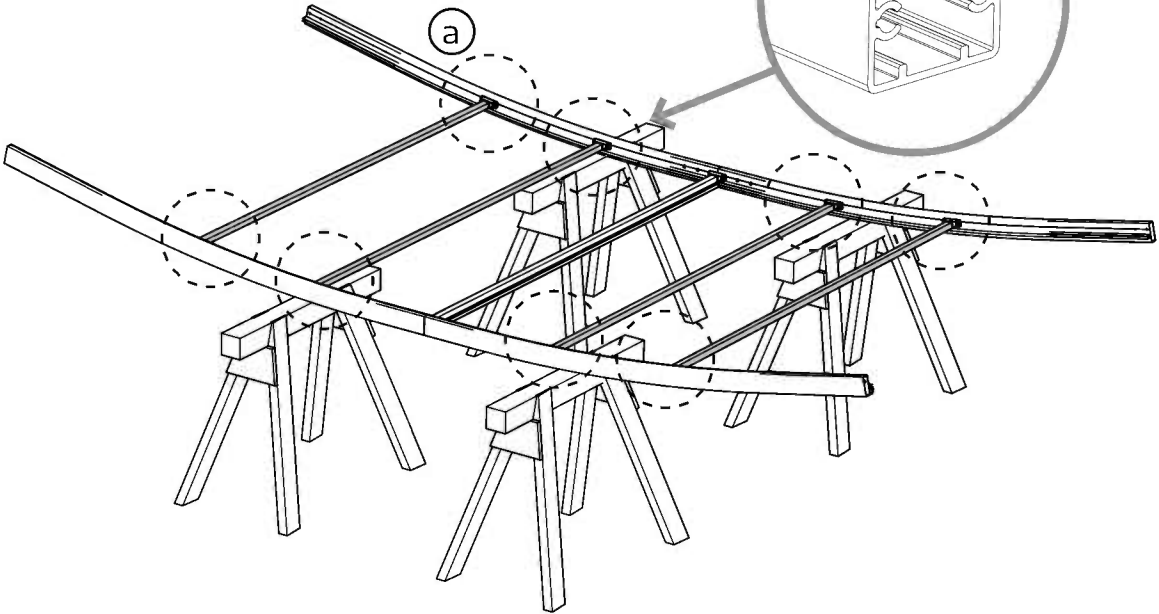
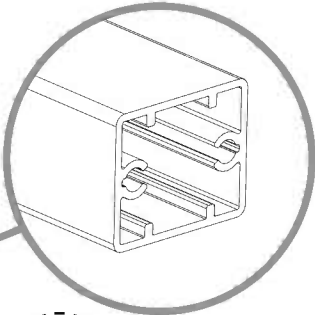
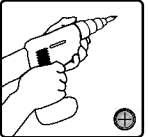
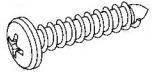

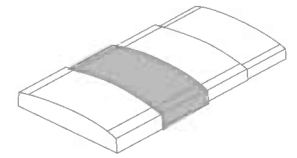

9051 4 9083 4

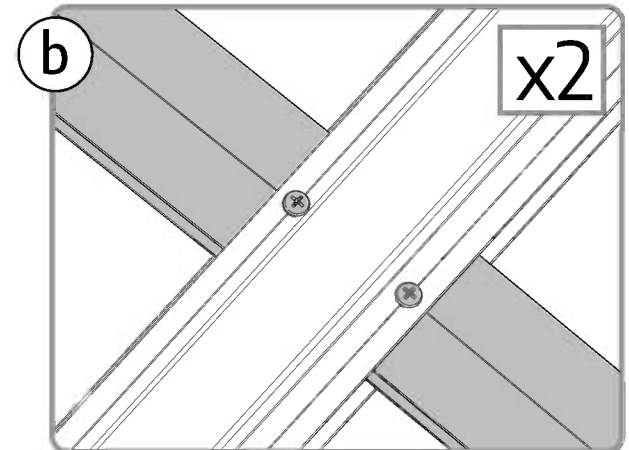
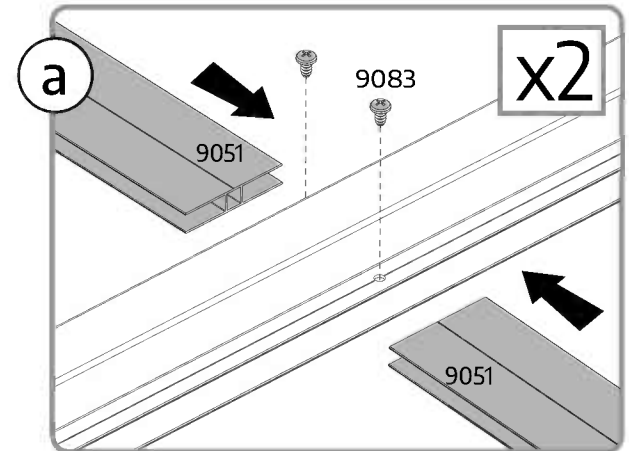
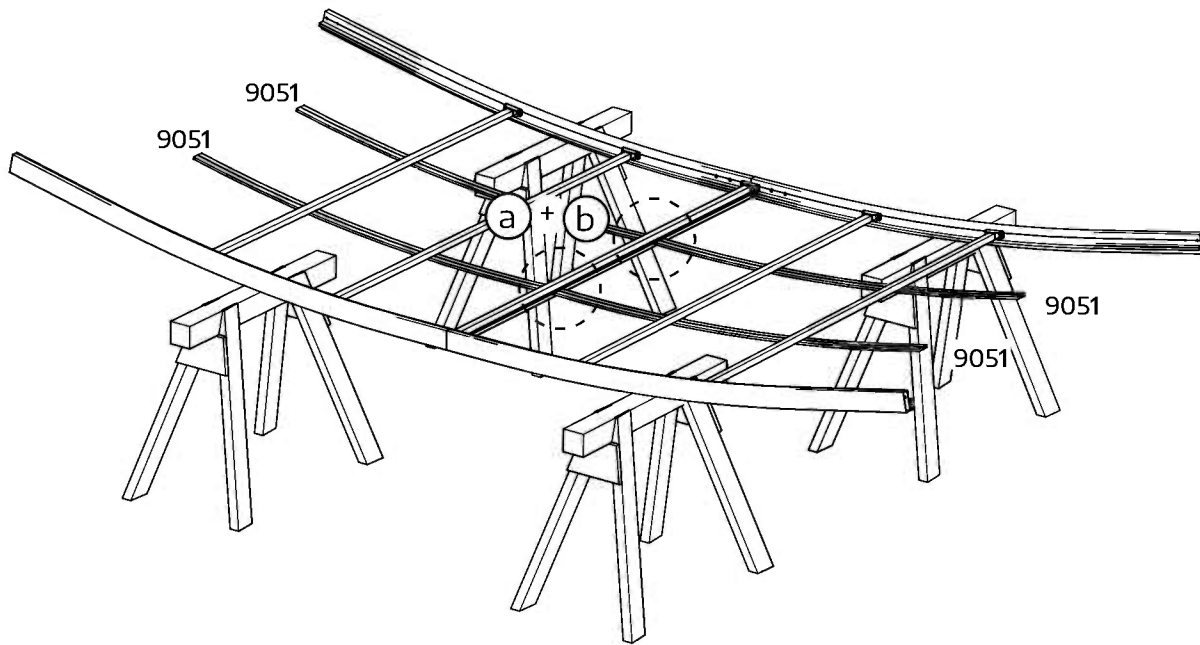
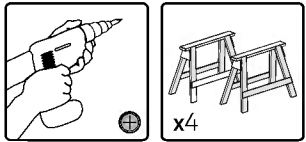

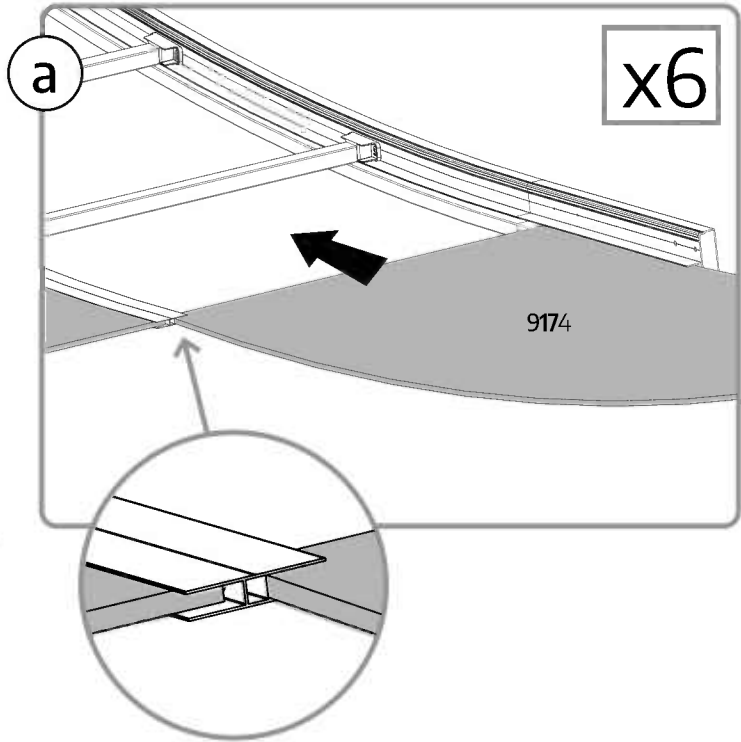
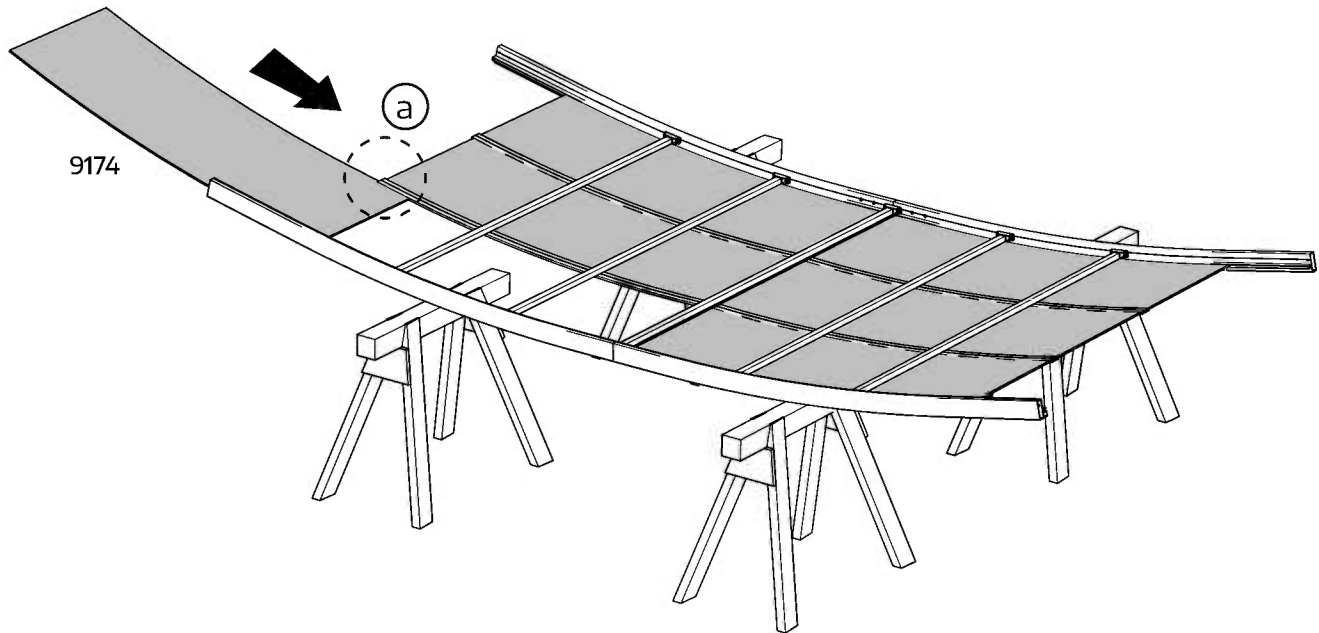
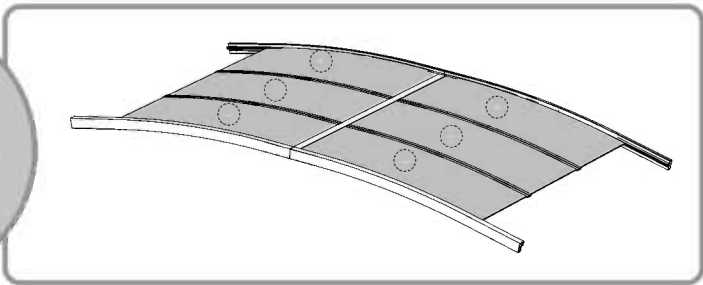
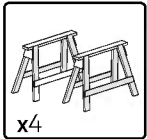
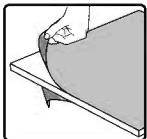
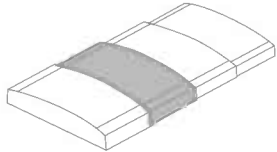

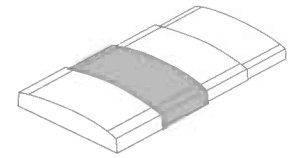

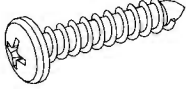
9082  8

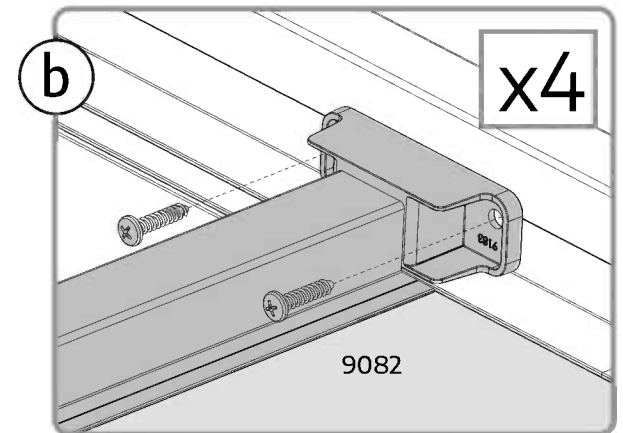
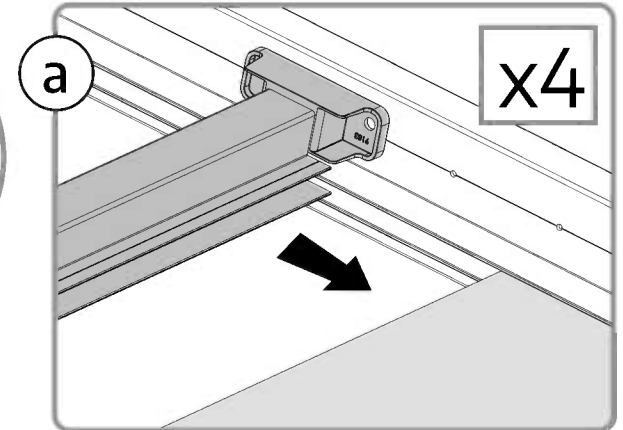
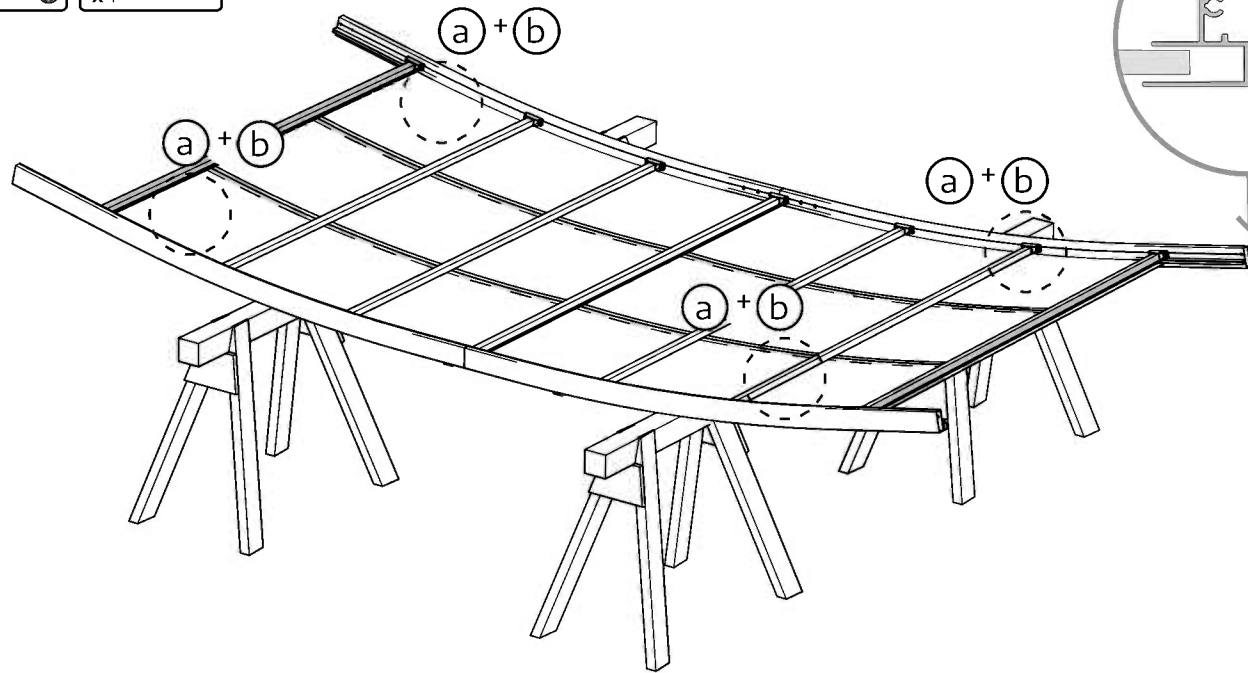
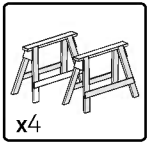
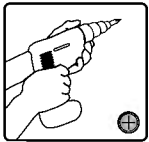

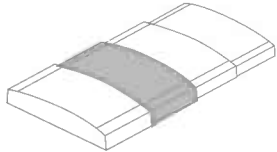

9083 4

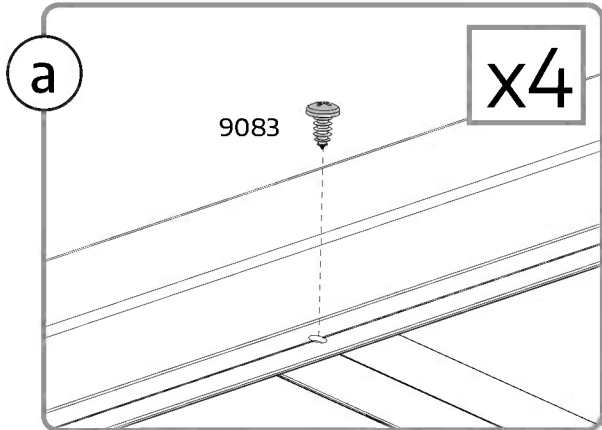
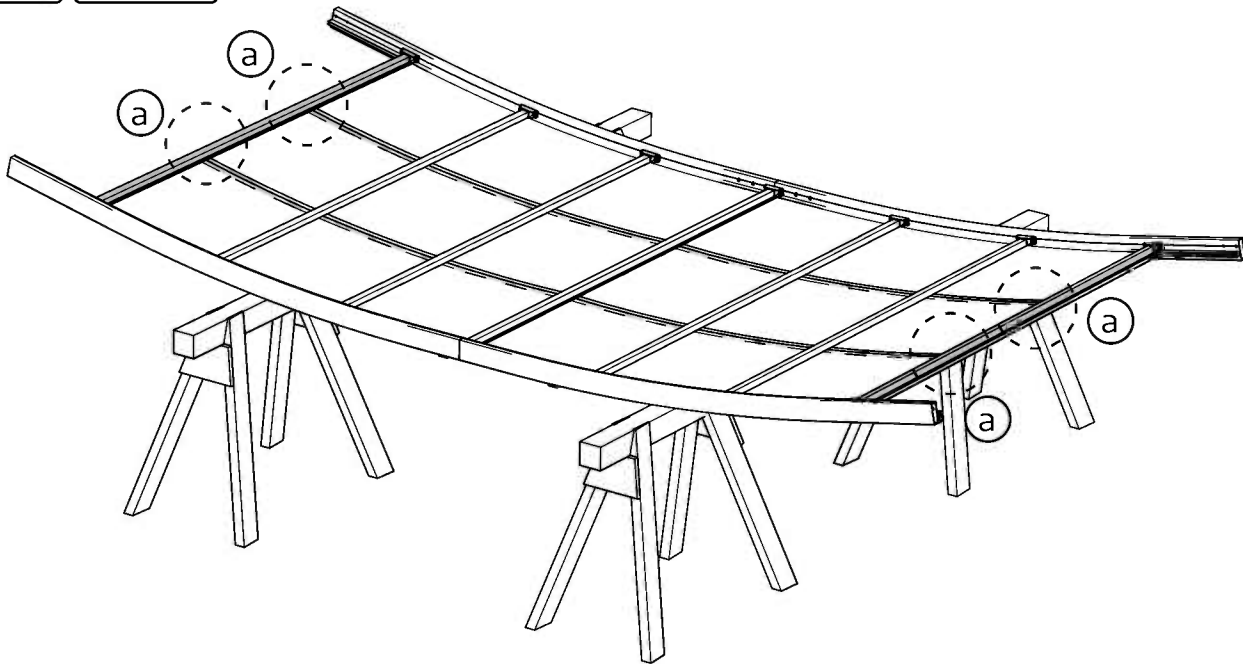
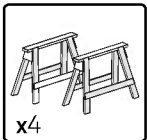
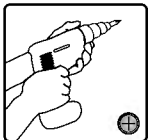
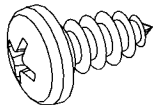

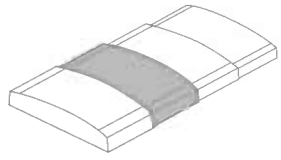

9177 2

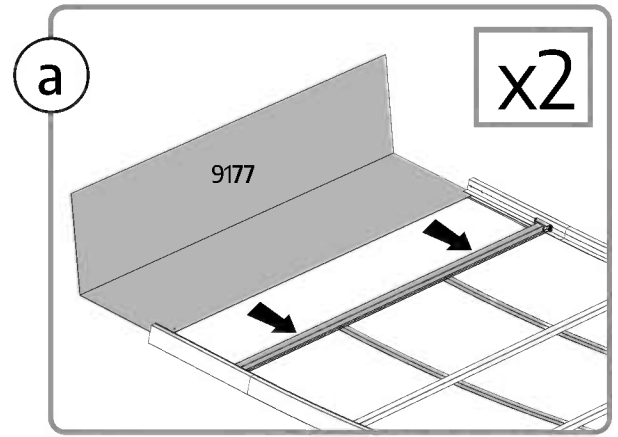
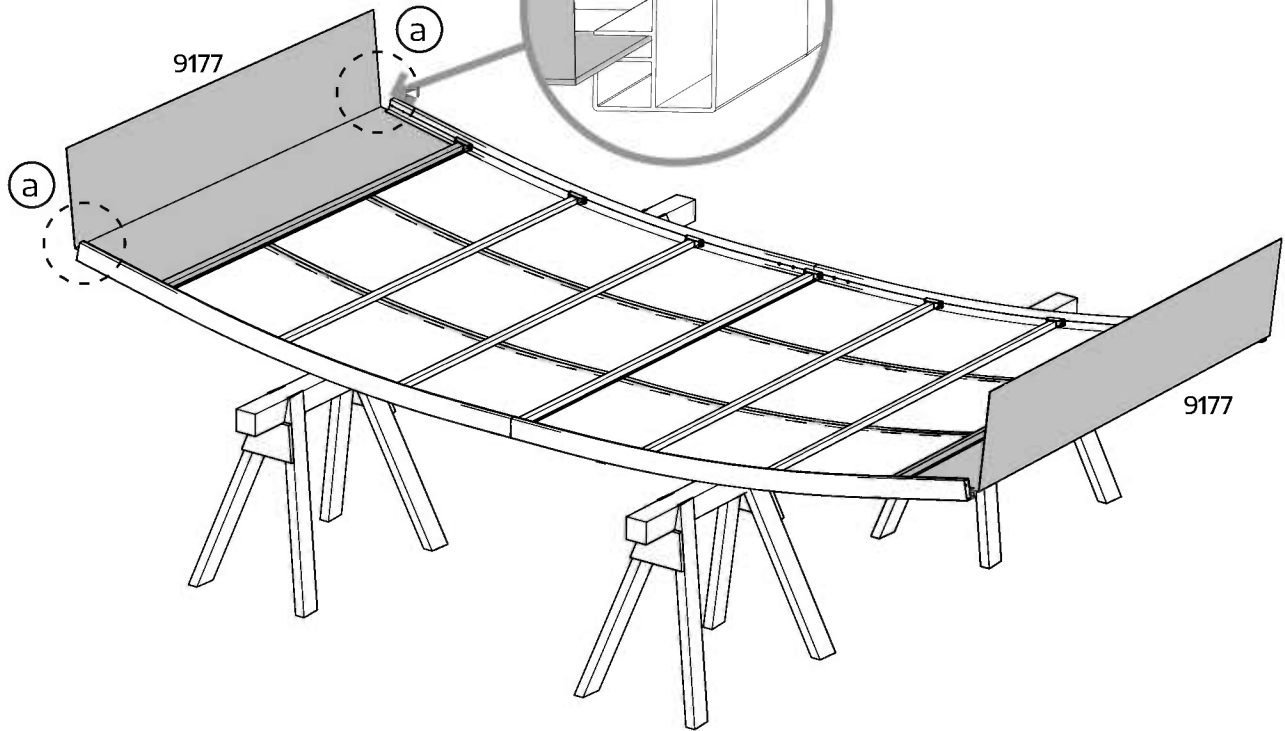
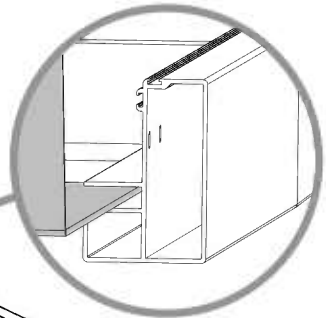
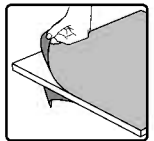
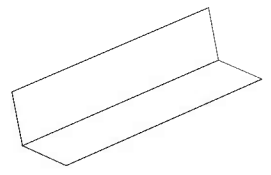

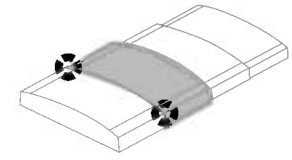

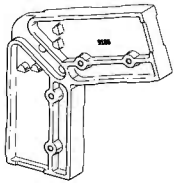
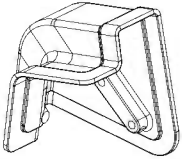
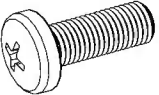
- 9186 2 9188 2 9067 4
- 
- 
- 

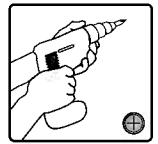

x2

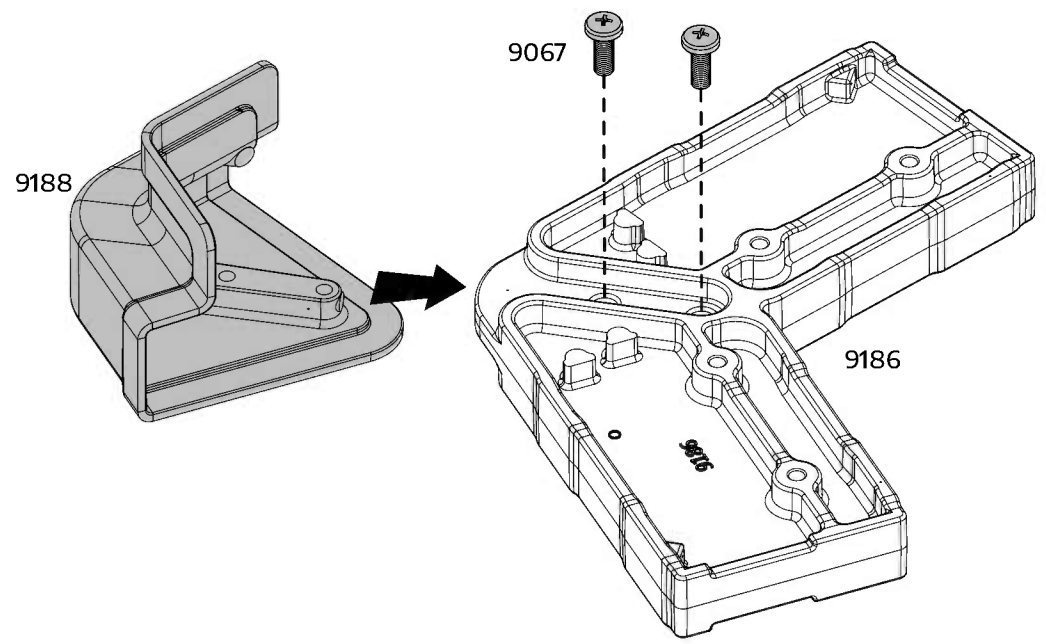

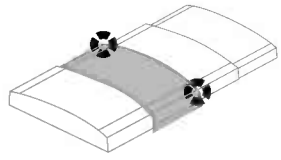

- 9186 2 9187 2 9067 4
-
- A parts list diagram showing three components: 9186 (a large L-shaped bracket), 9187 (a smaller L-shaped bracket), and 9067 (a screw). Each component is accompanied by a small illustration and a quantity of 2, 2, and 4 respectively.

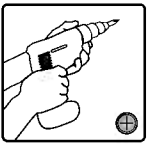

x2

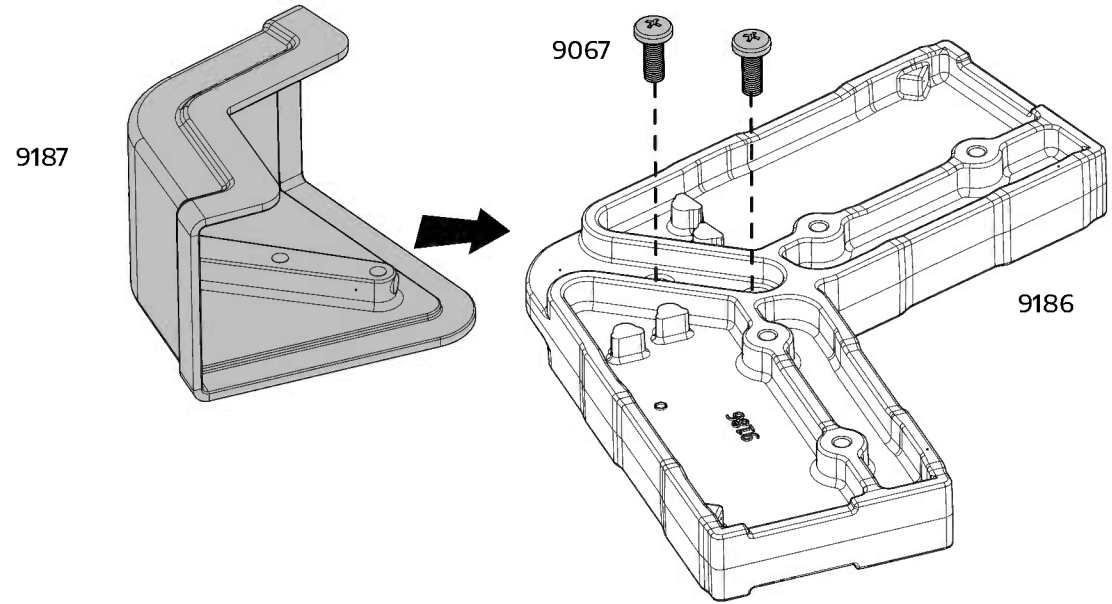

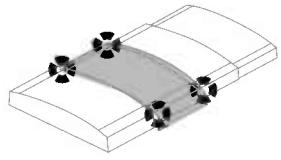

9066 8

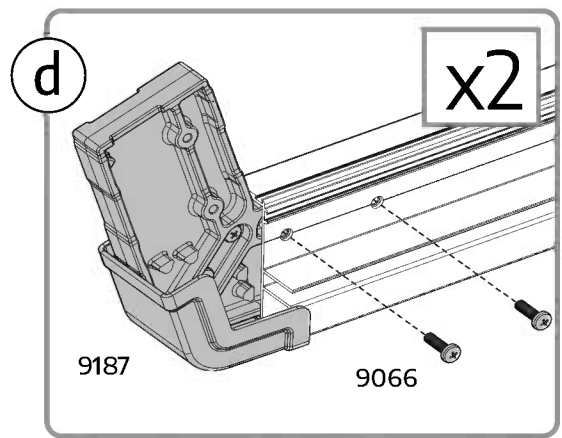
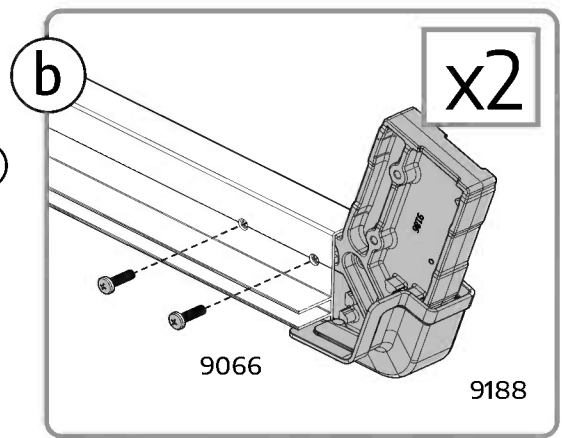
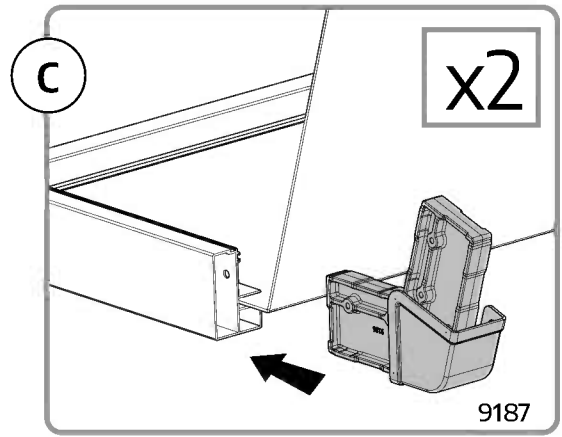
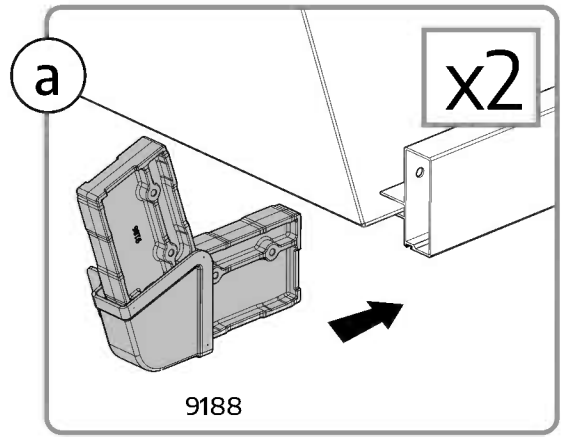
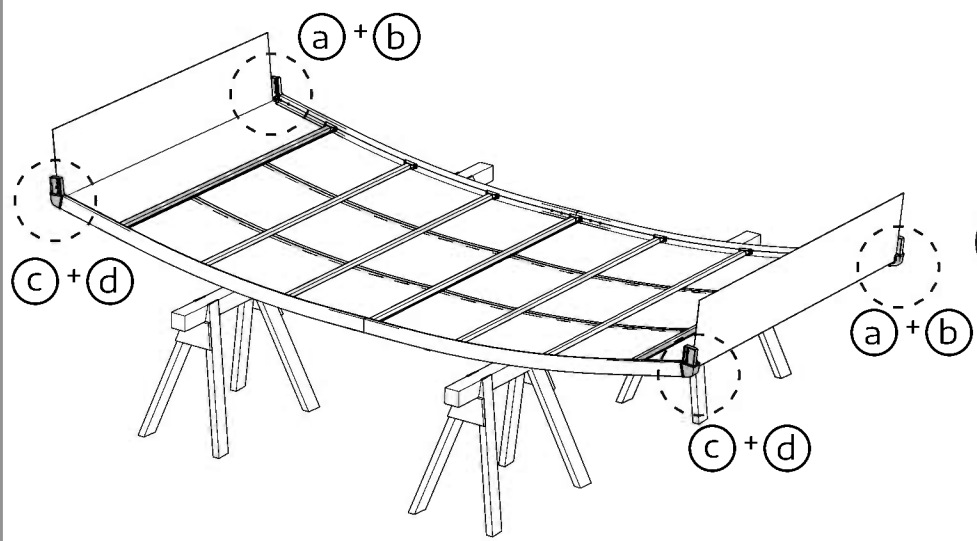
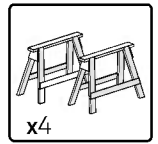
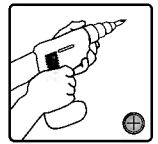
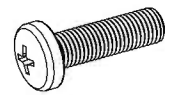

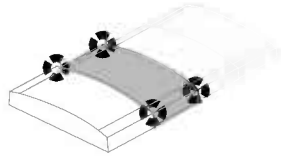

- 9064 2
- 9080 2
- 9066 8

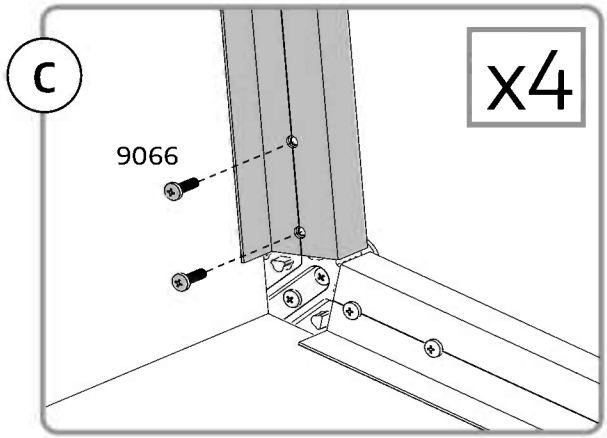
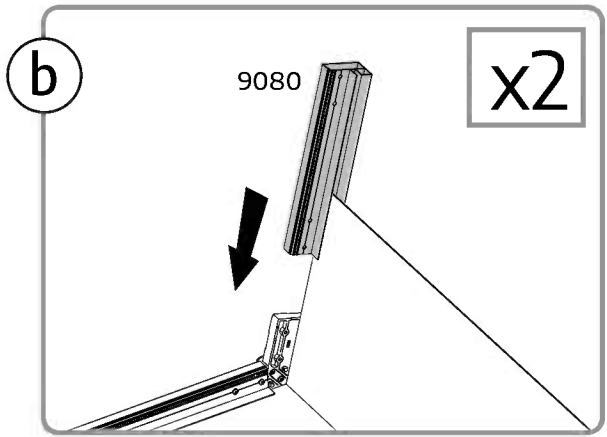
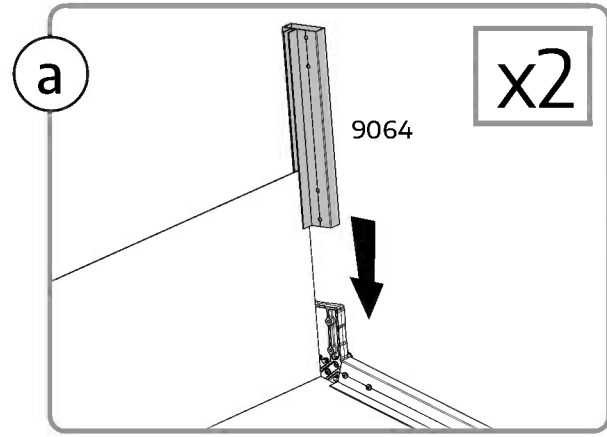
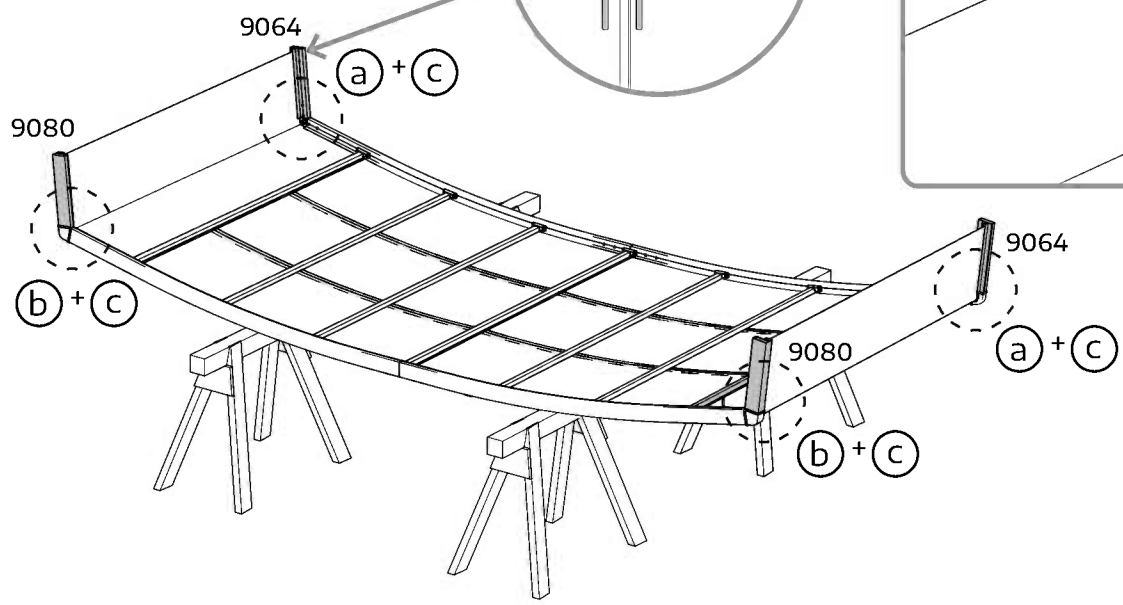
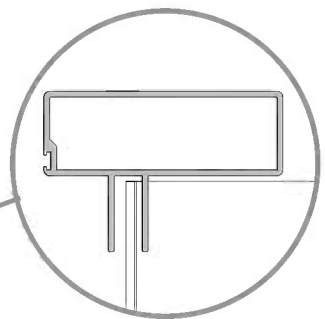
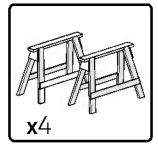
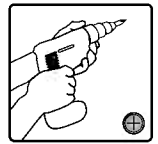

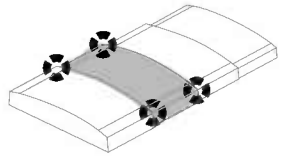

9066 8

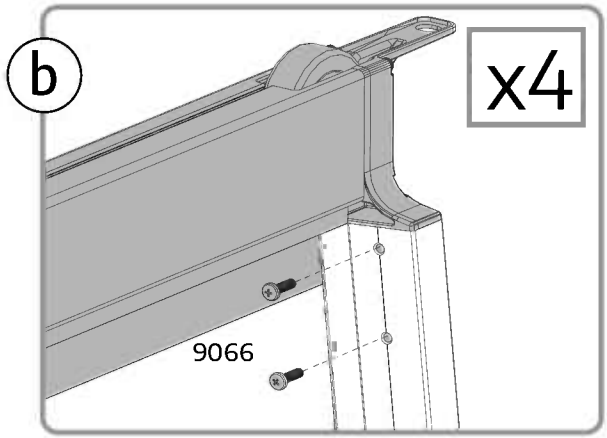
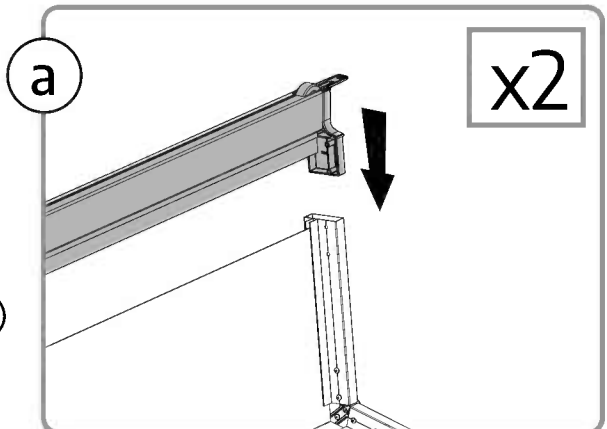
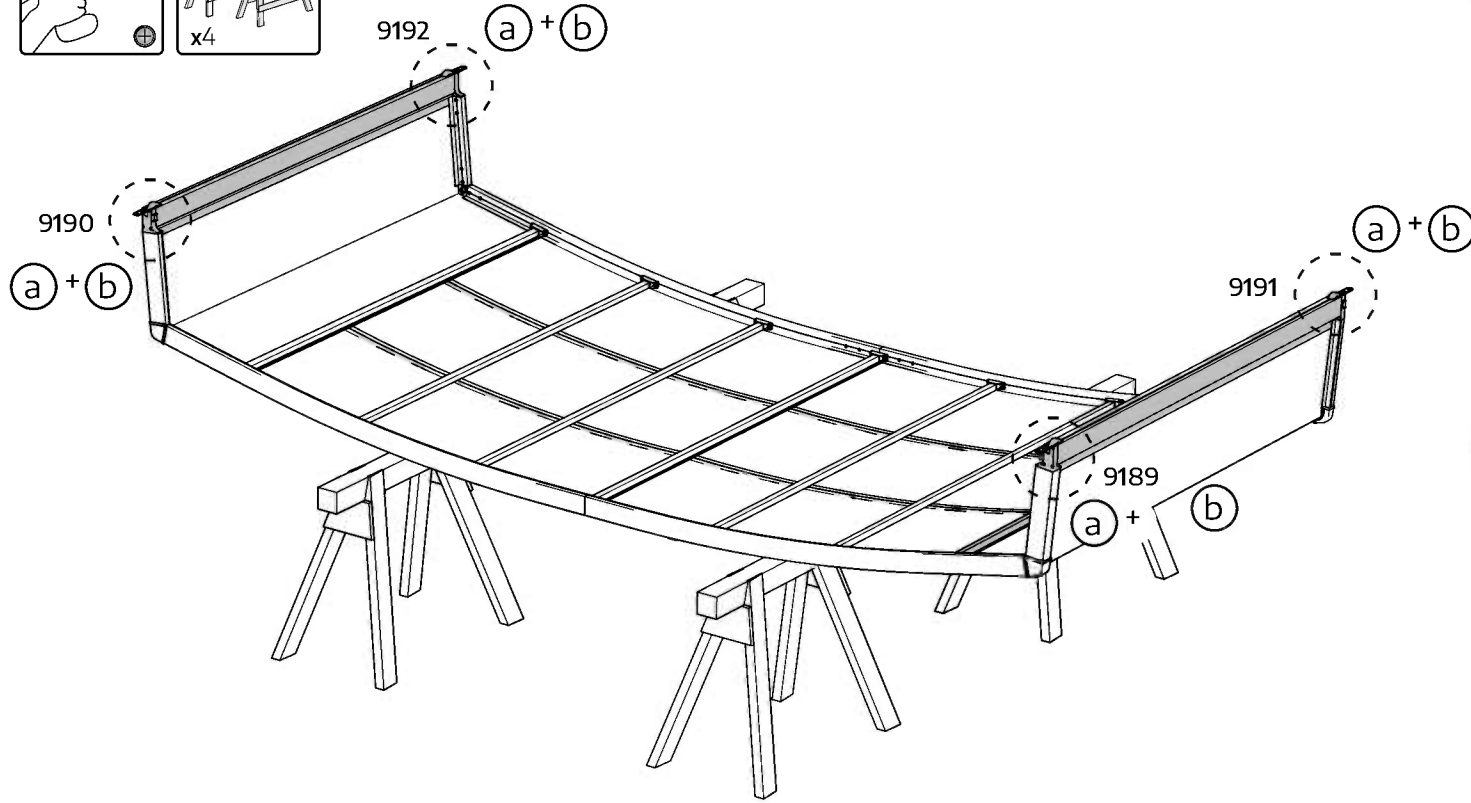
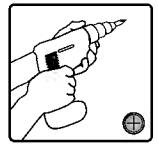
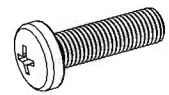

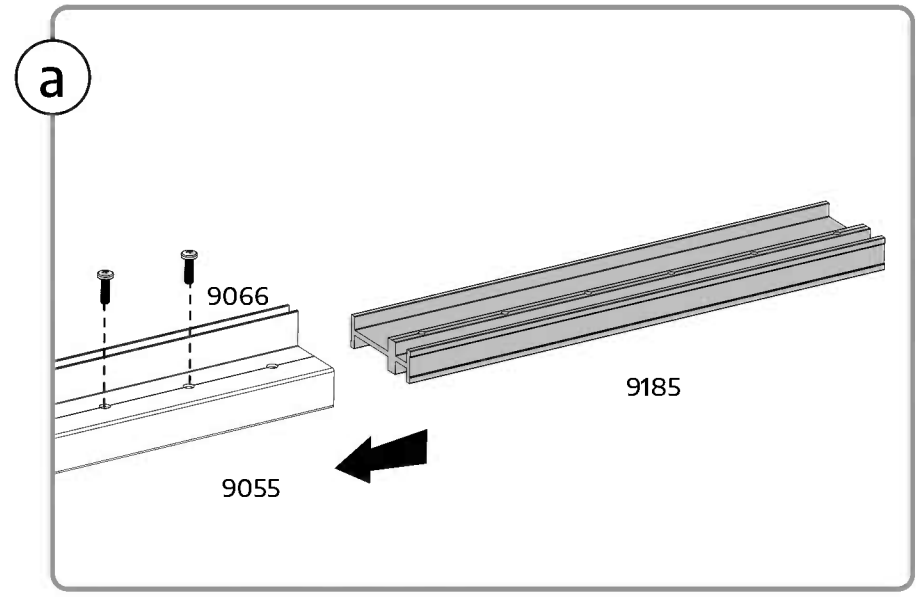
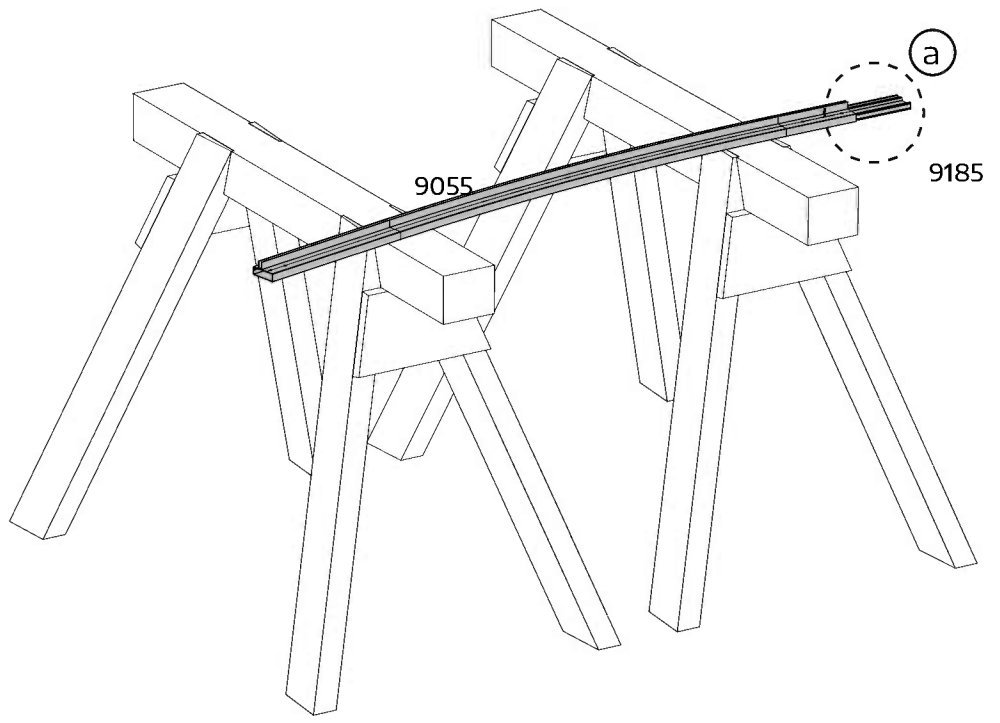
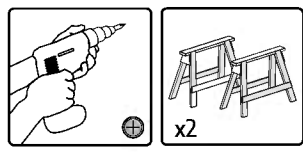
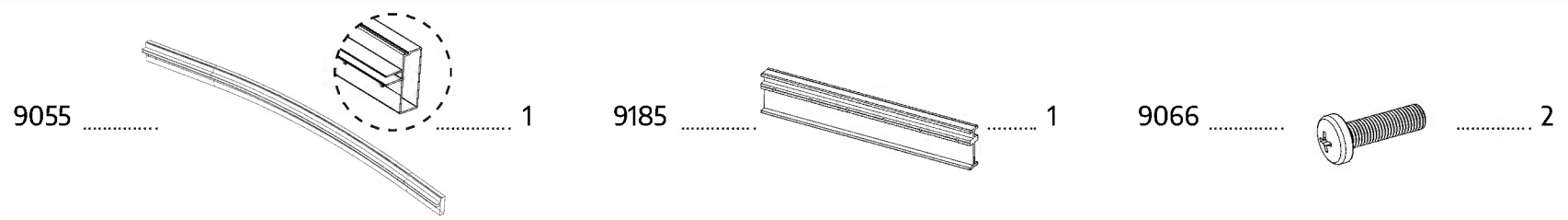
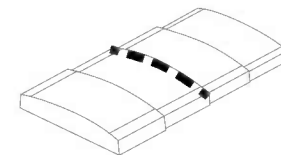

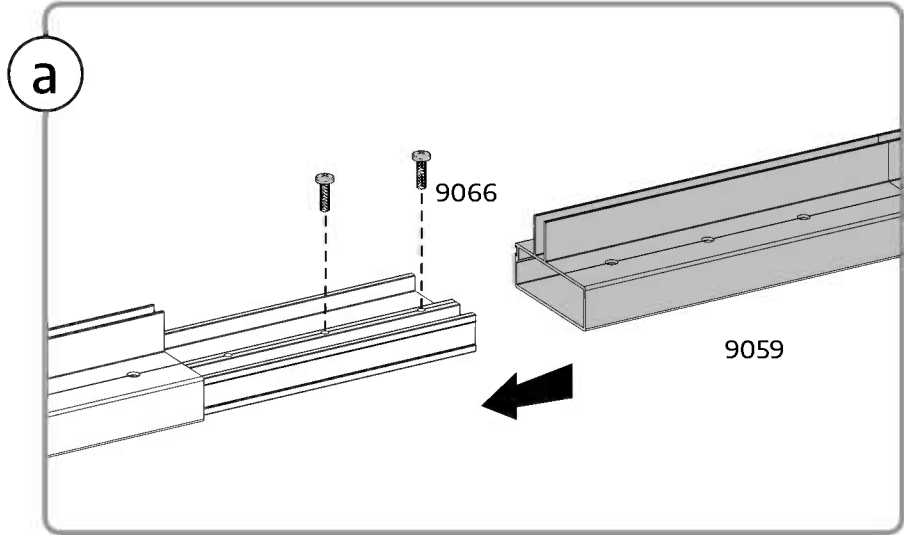
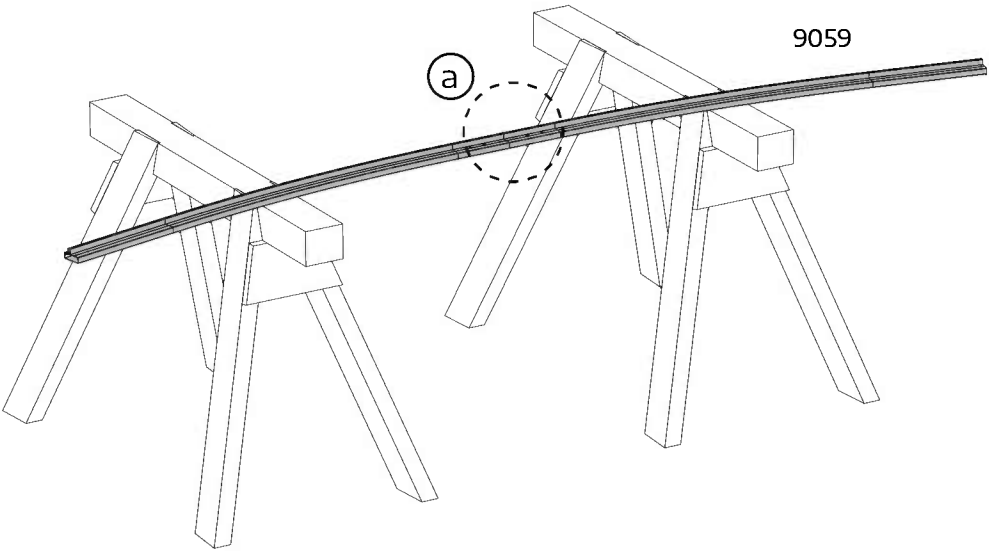
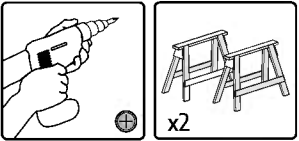
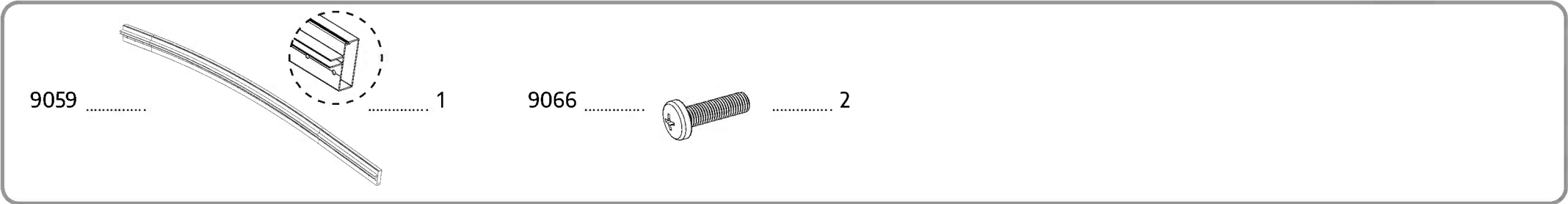
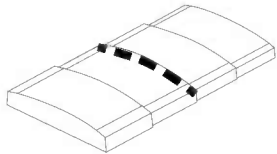

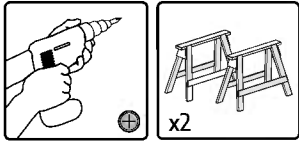
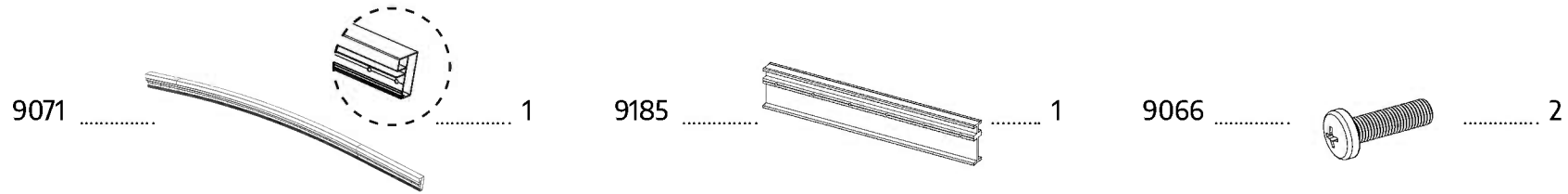
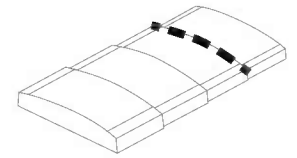

x2

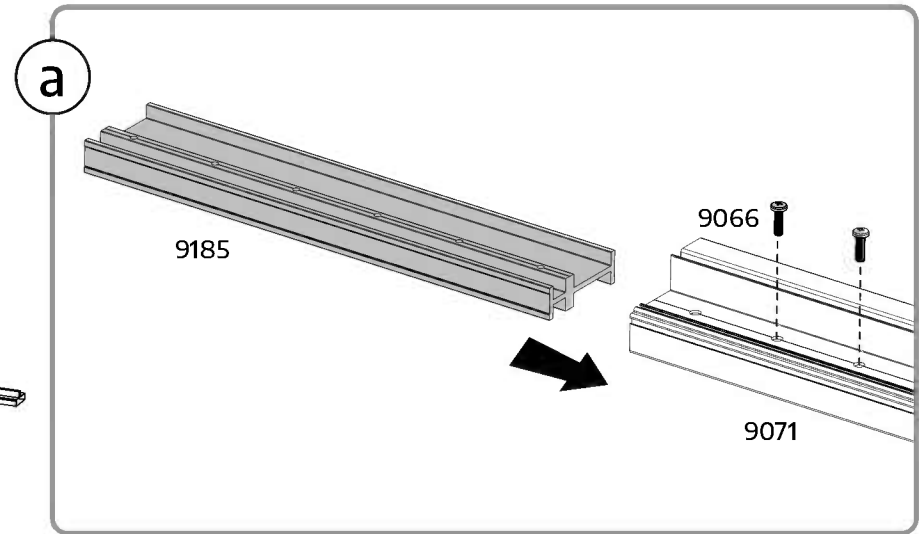
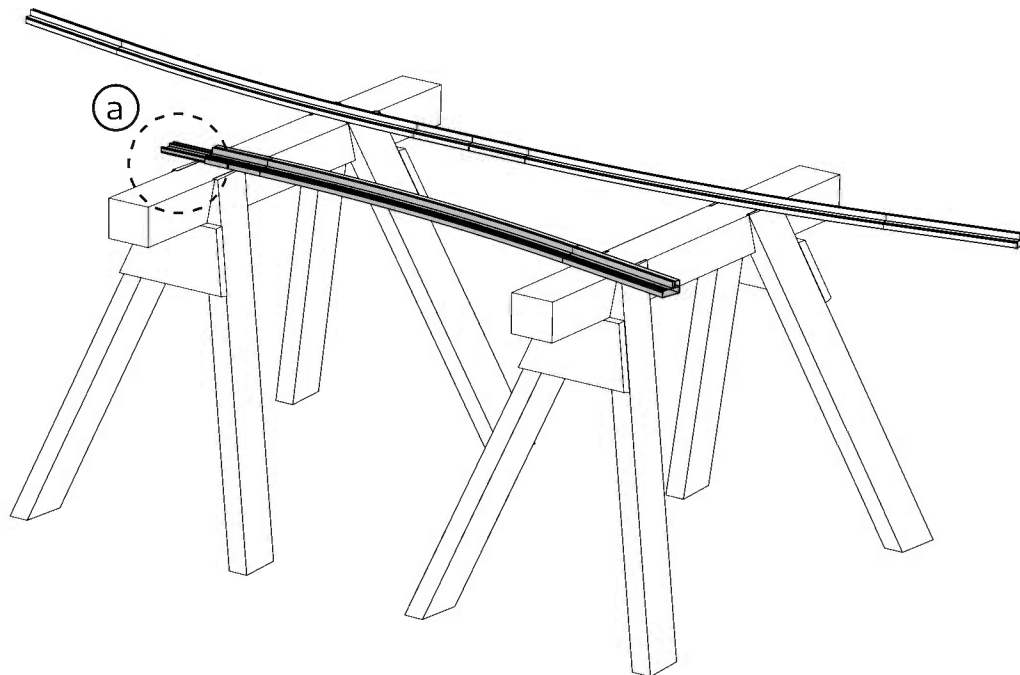

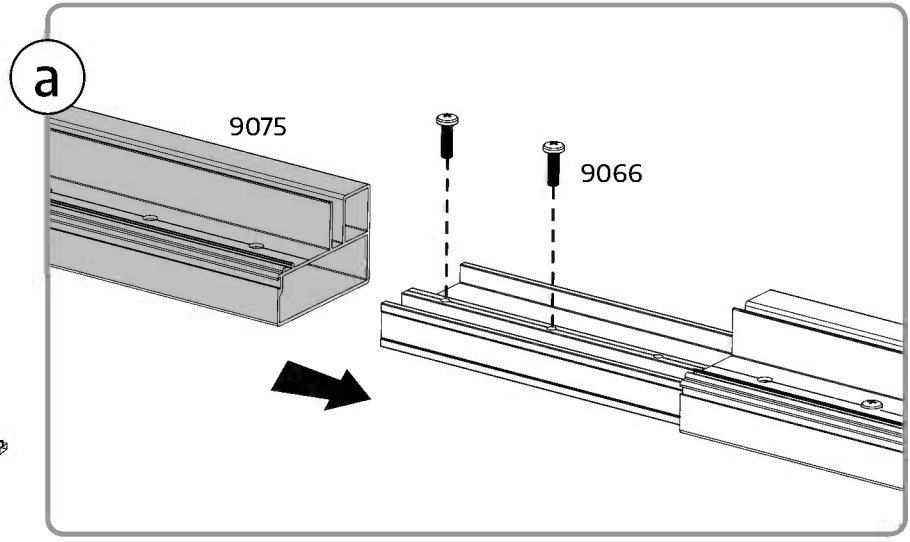
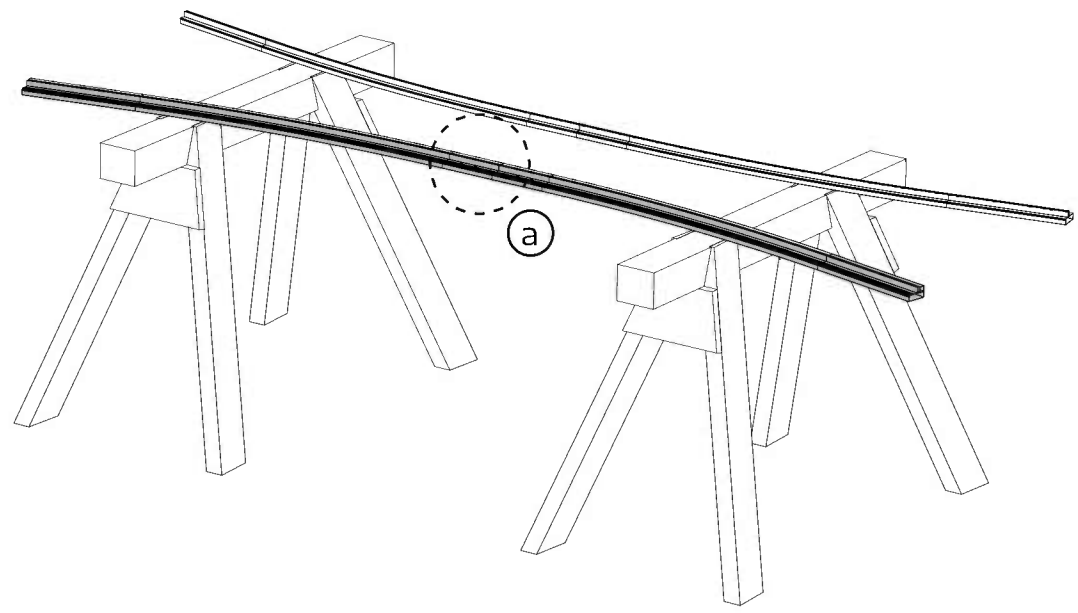
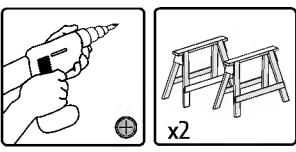
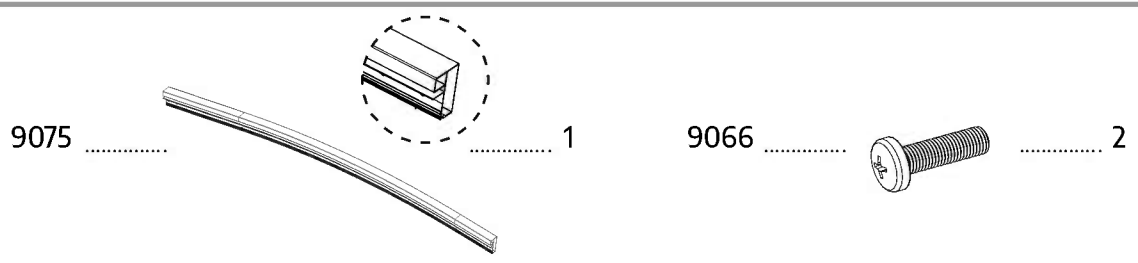
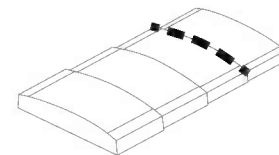

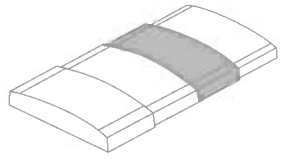

9066 4

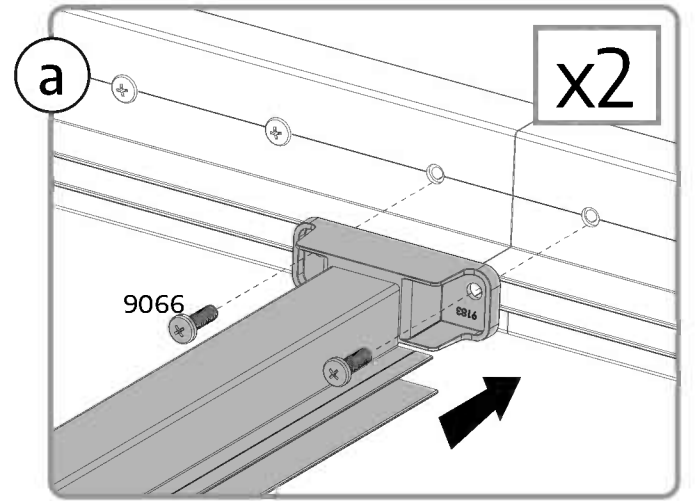
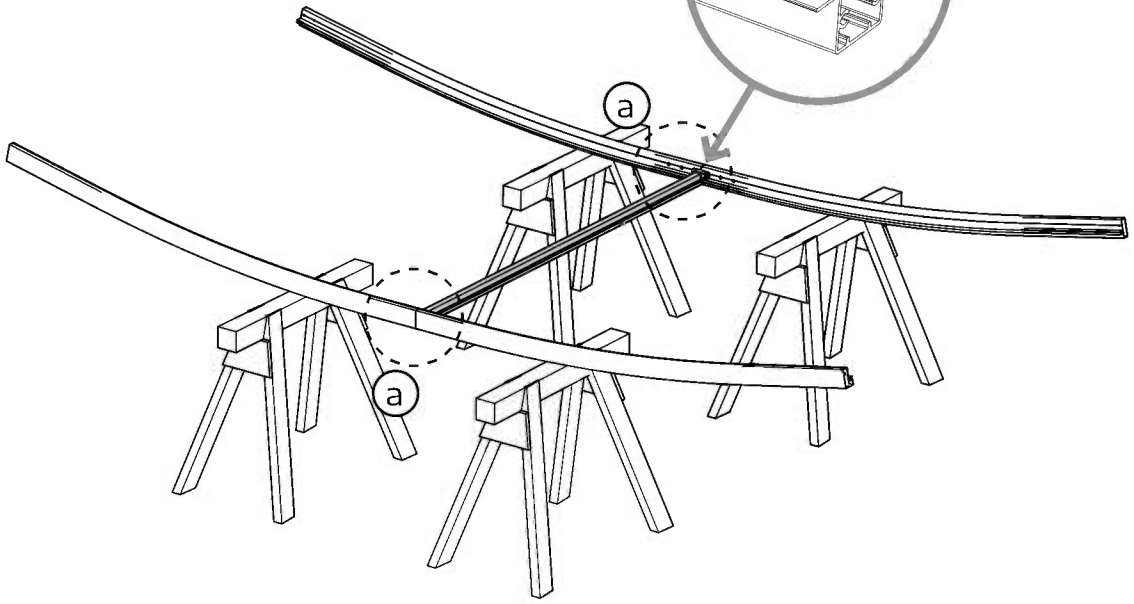
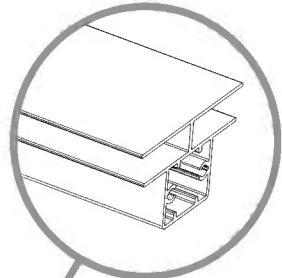
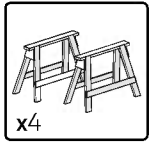
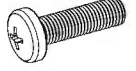

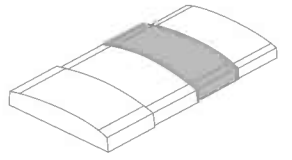

9082 16

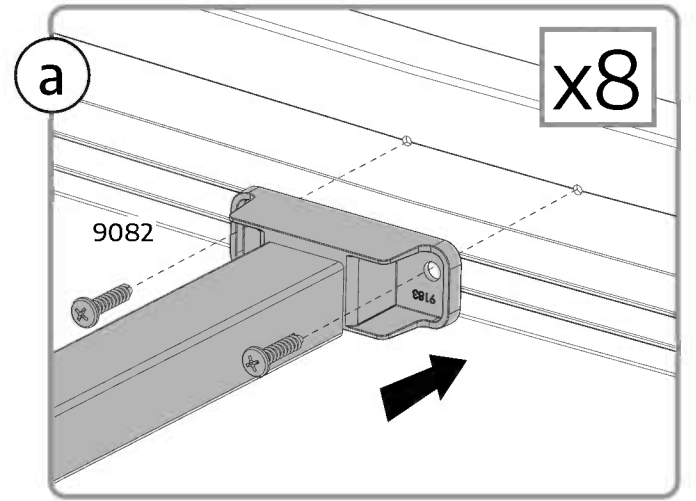
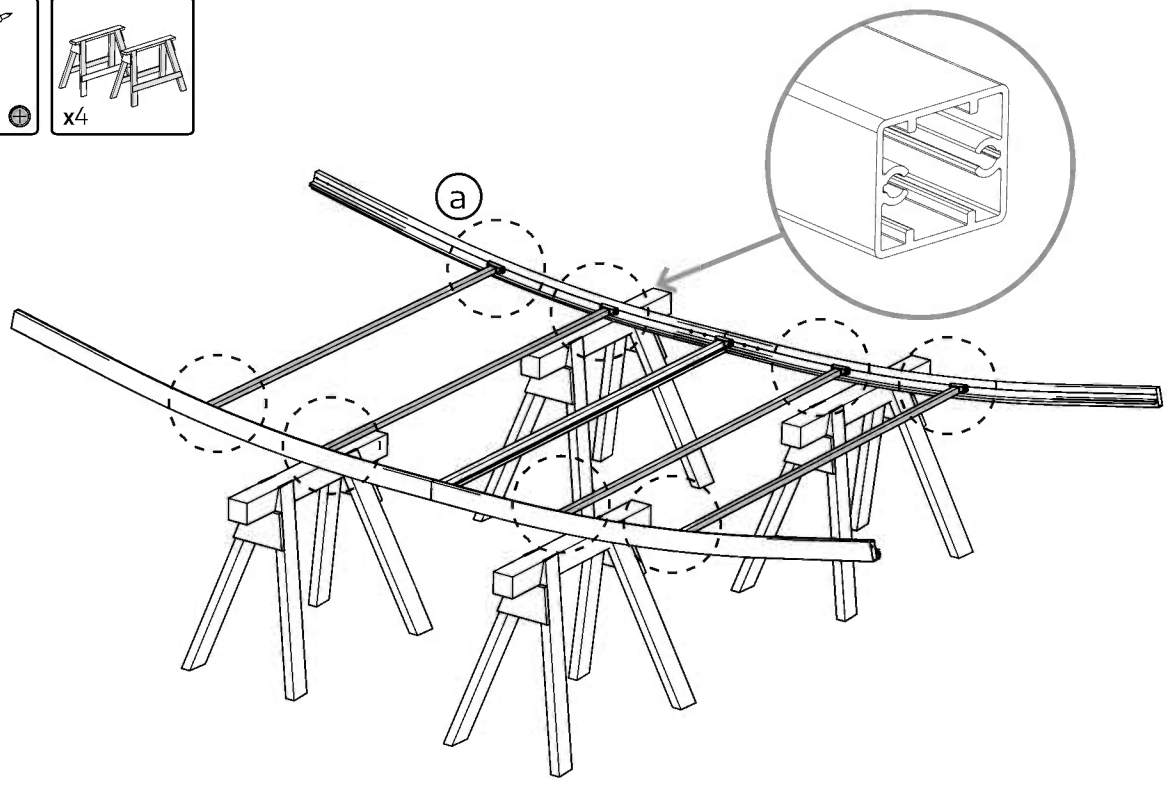
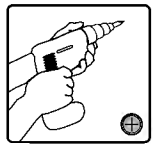
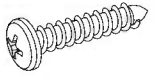

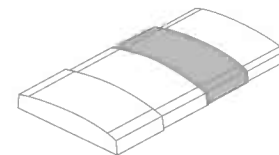

- 9051 4
- 9083 4

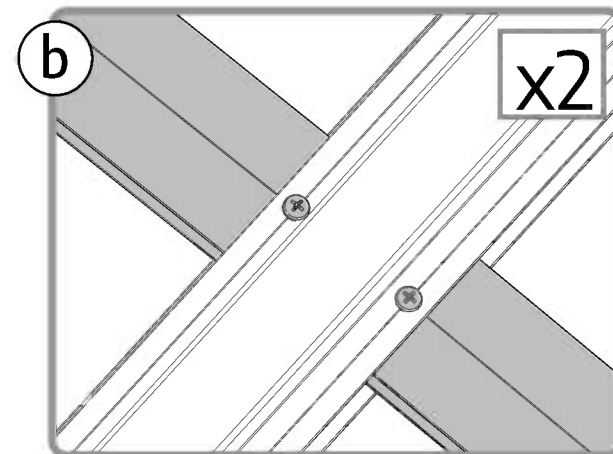
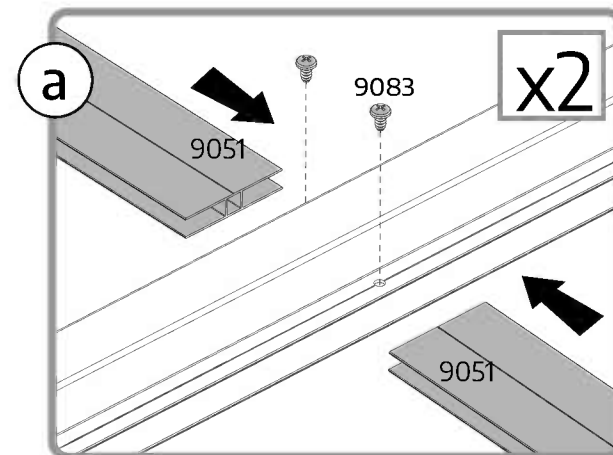
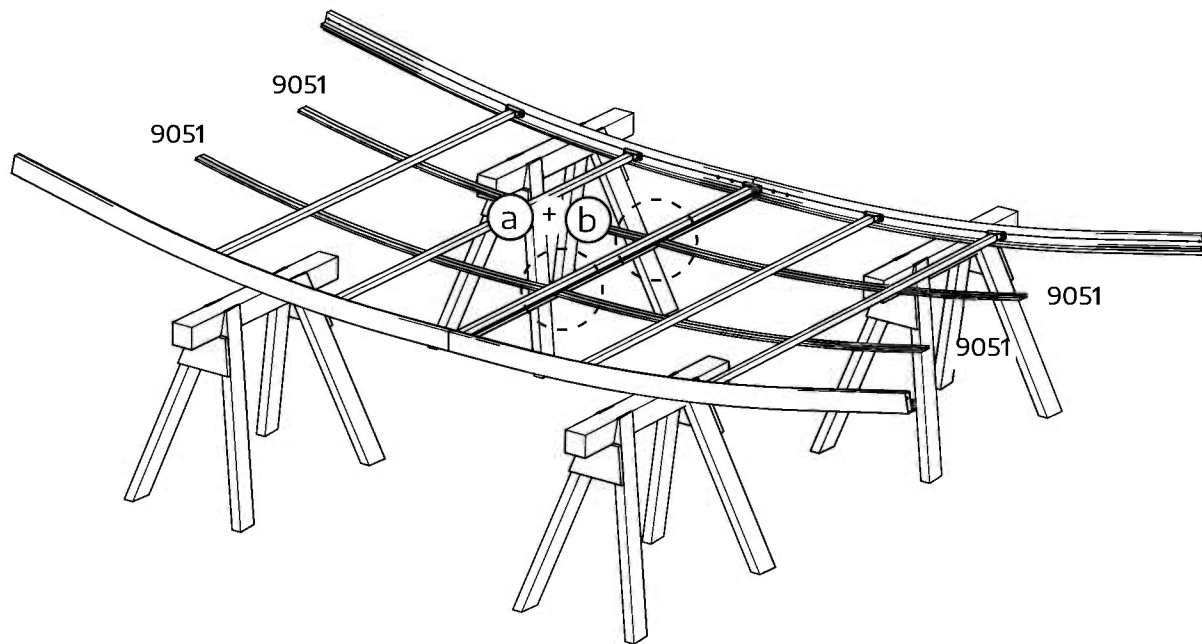
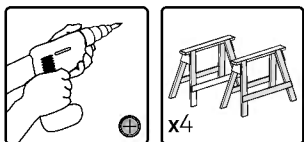

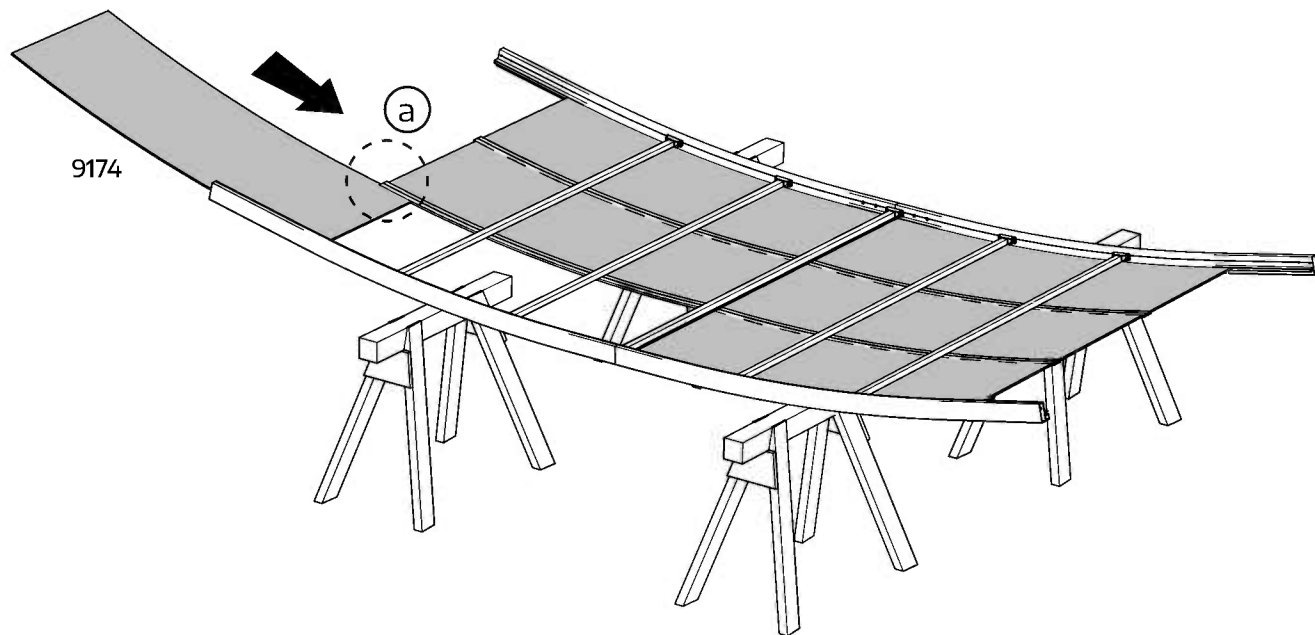
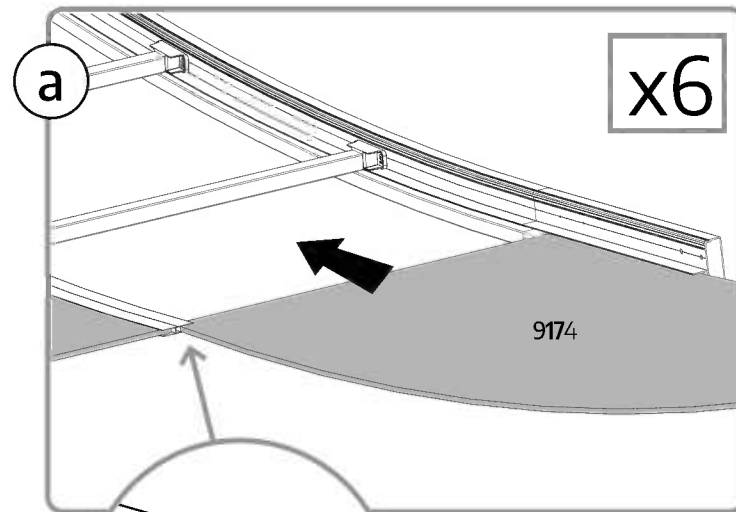
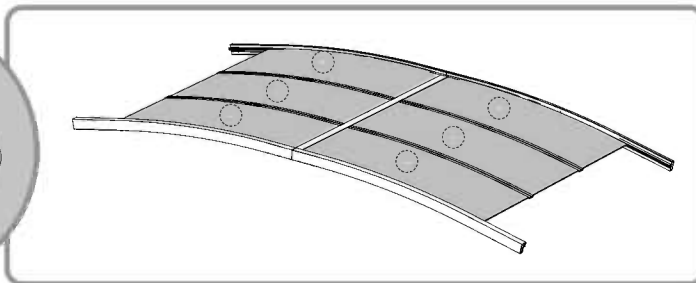
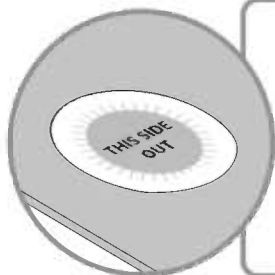
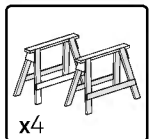
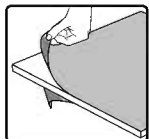
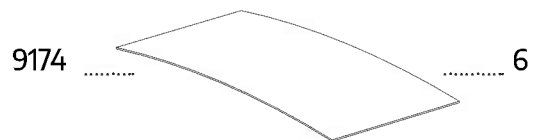
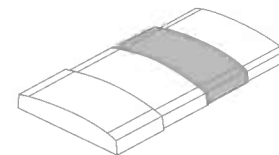

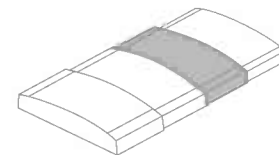

9082 8

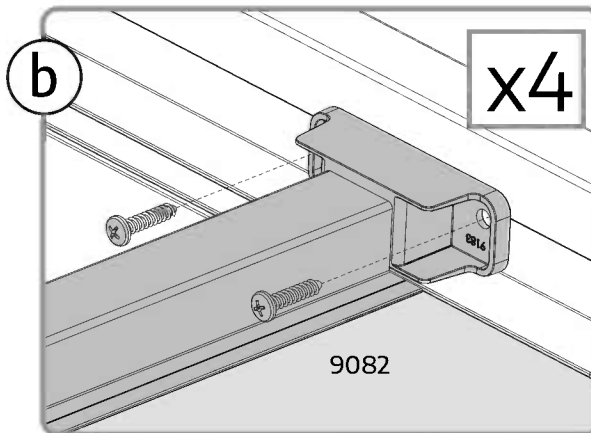
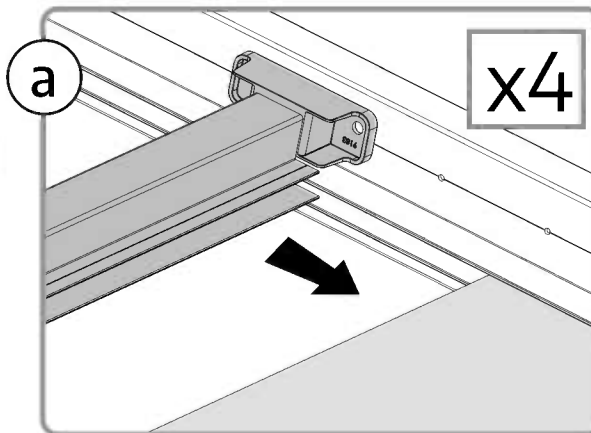
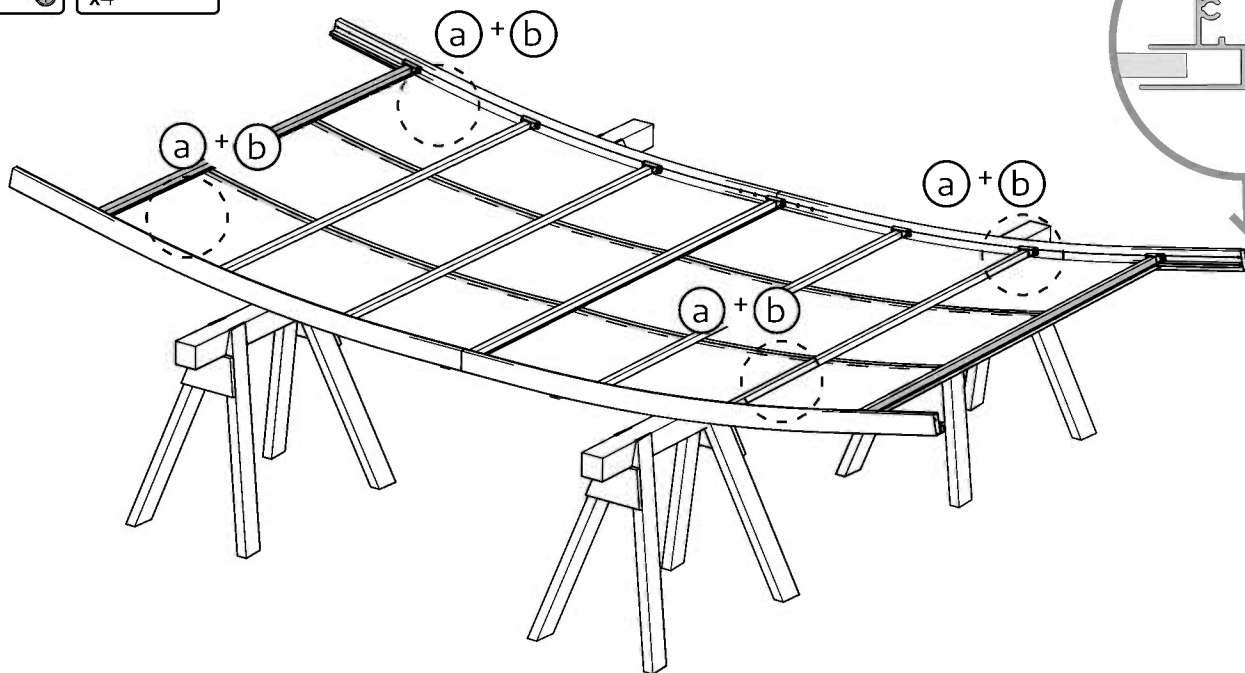
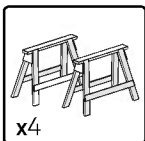
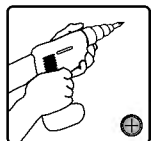
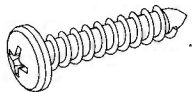

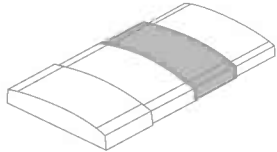

9083 4

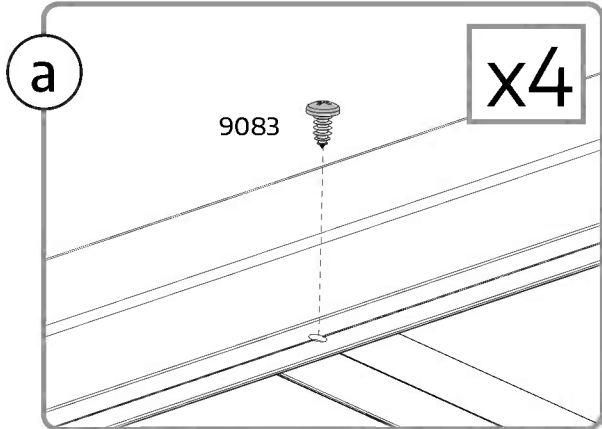
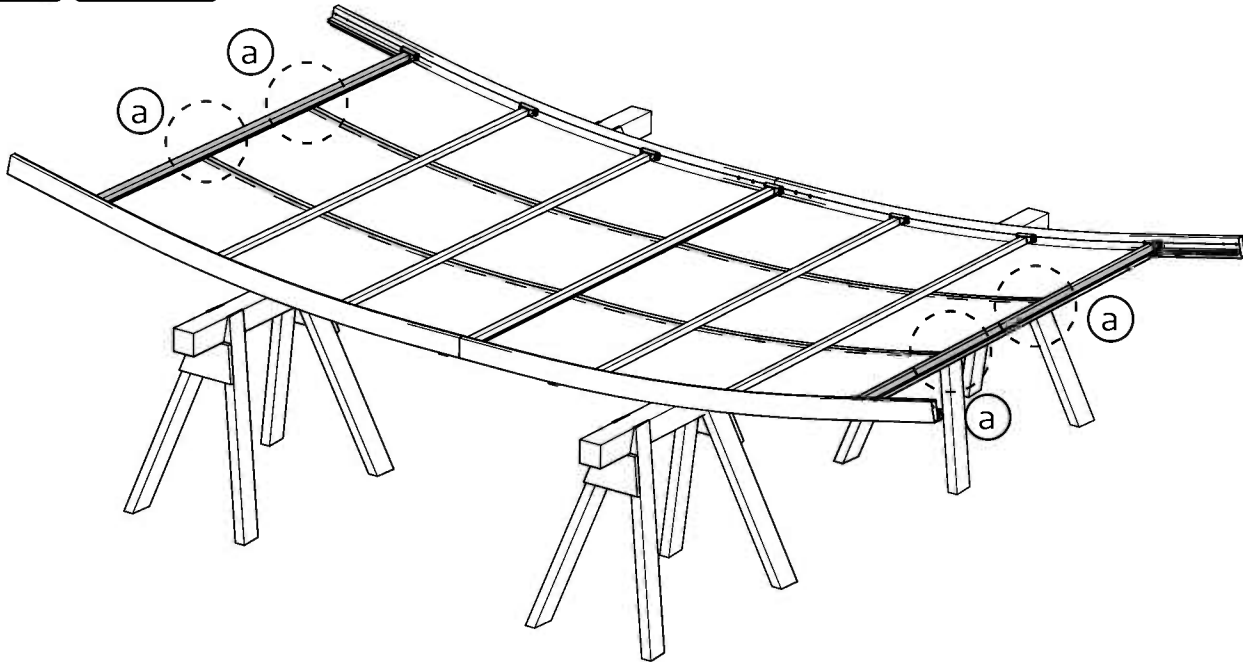
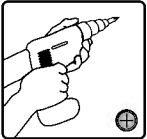
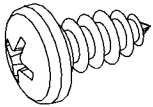

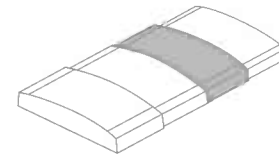

9176 2

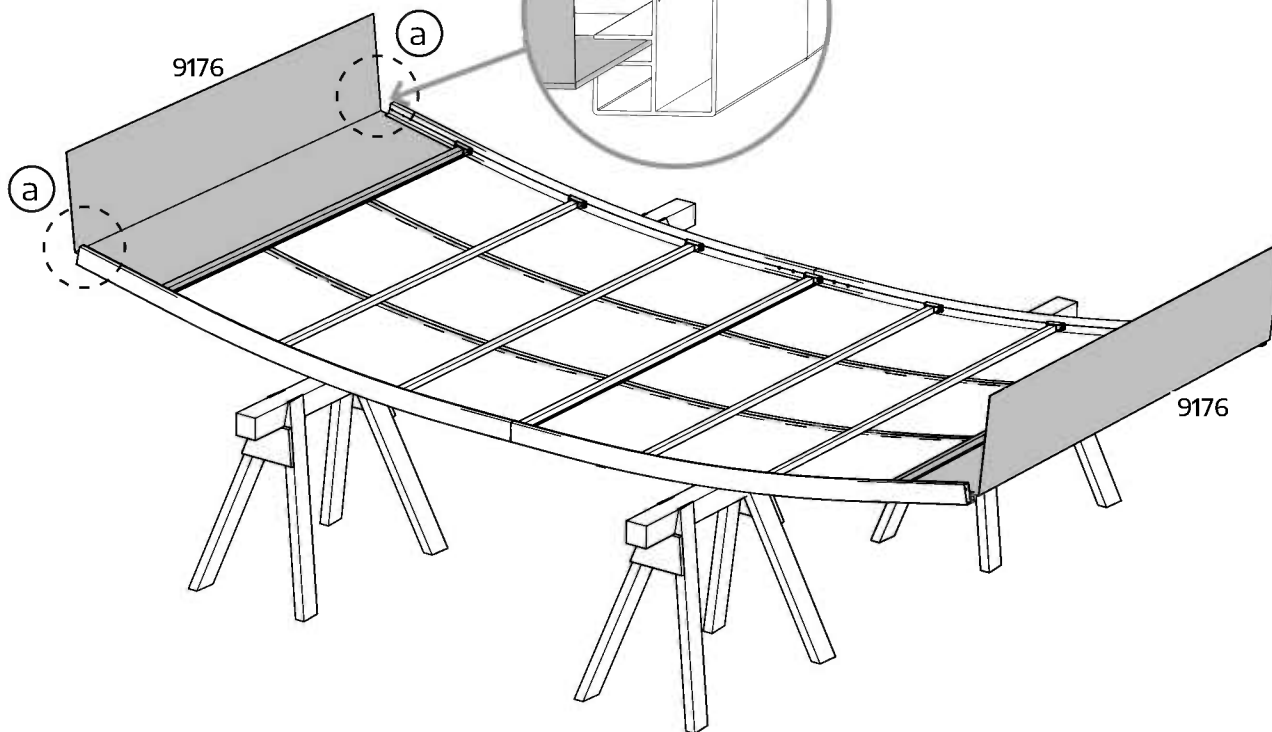
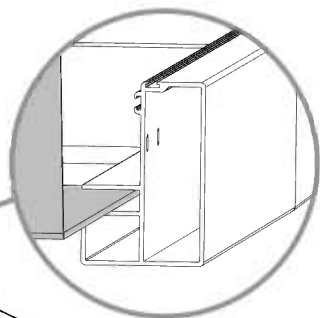
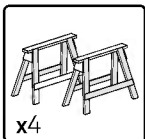
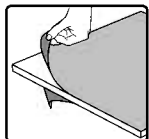
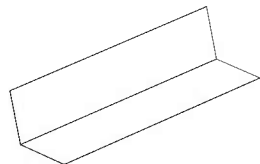

a

x2

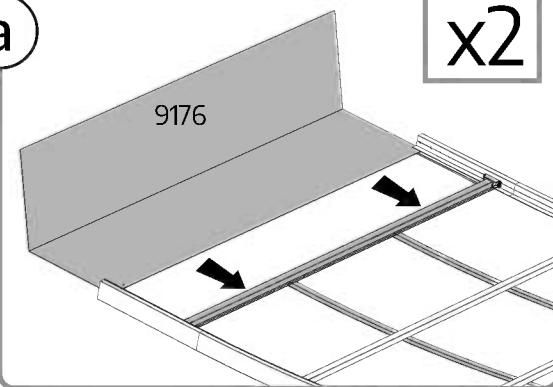

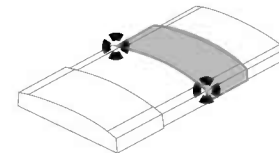

- 9186 2 9188 2 9067 4
-
- A parts list diagram showing three items: 9186, 9188, and 9067. 9186 is a large L-shaped plastic component. 9188 is a smaller L-shaped plastic component. 9067 is a screw with a Phillips head and a hexagonal base.

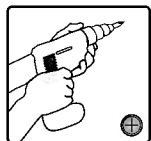

x2

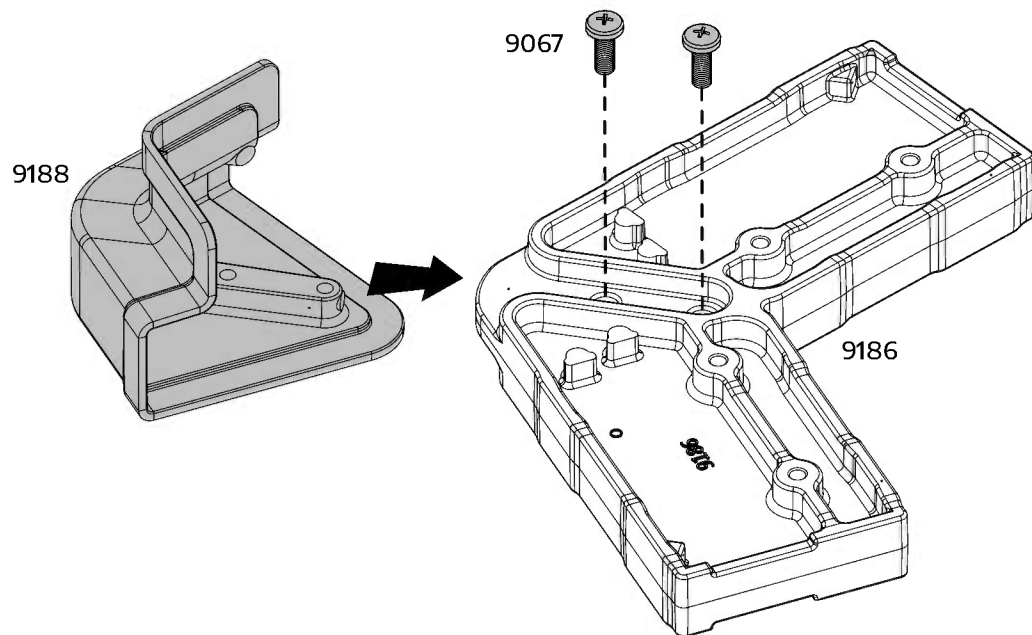

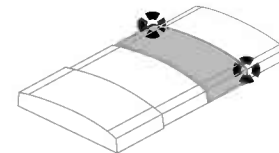

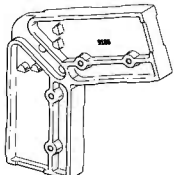
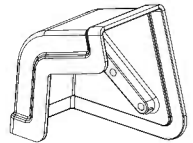
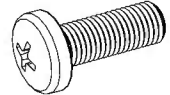
- 9186 2 9187 2 9067 4
- 
- 
- 

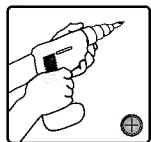

x2

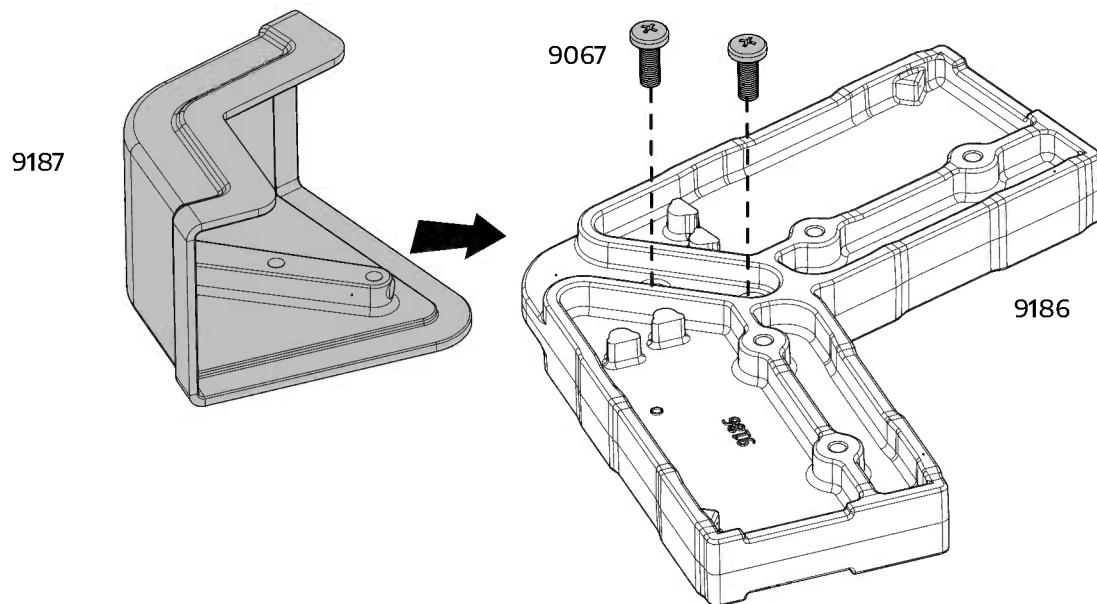

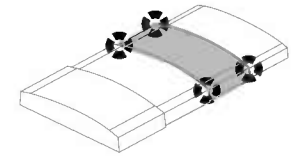

9066 8

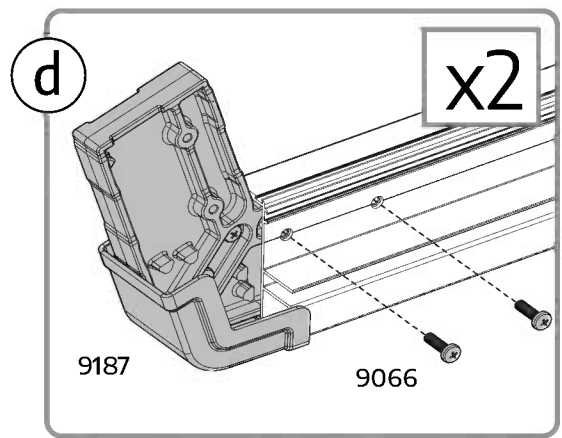
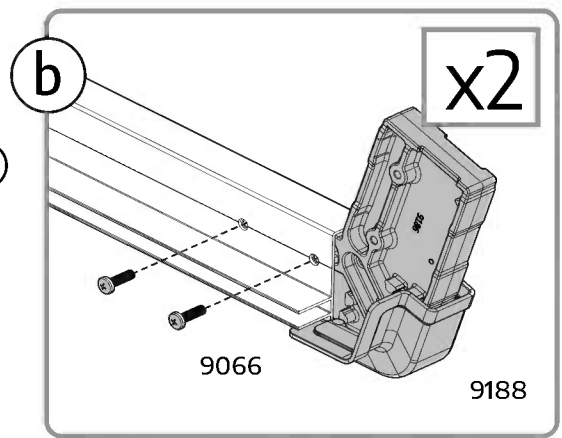
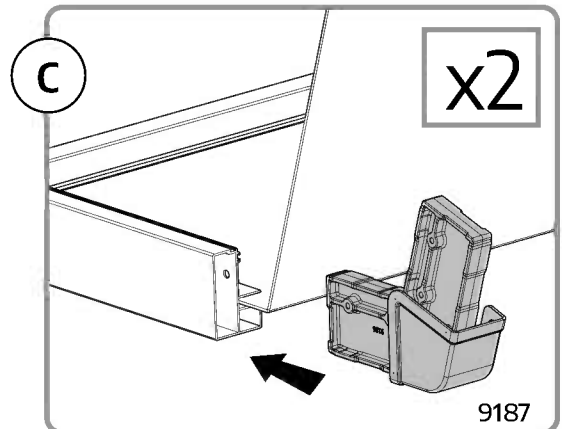
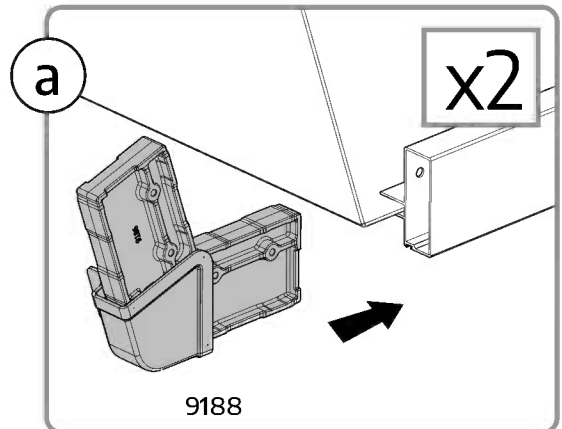
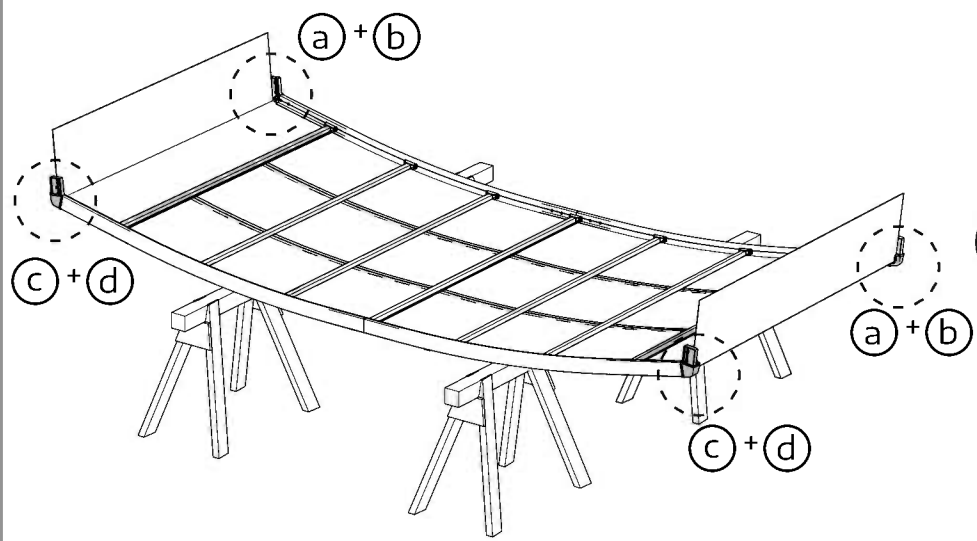
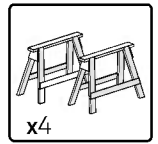
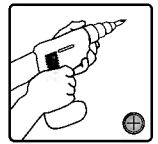
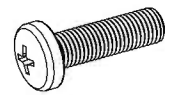

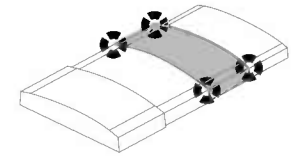

- 9063 2 9079 2 9066 8
-

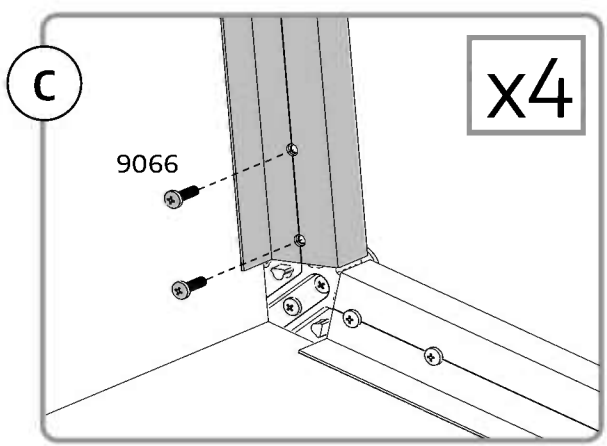
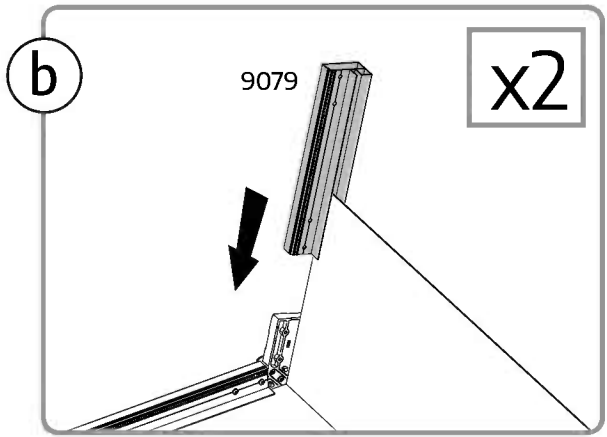
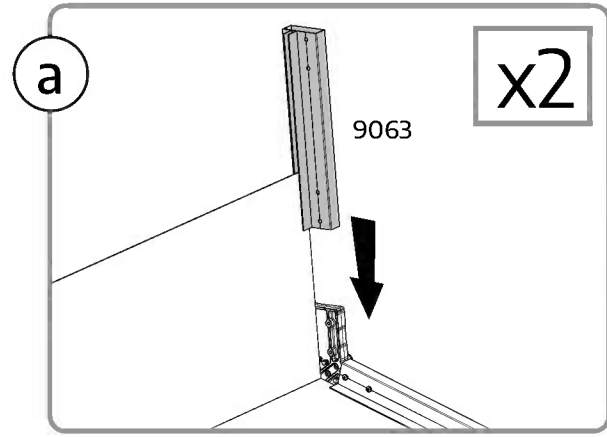
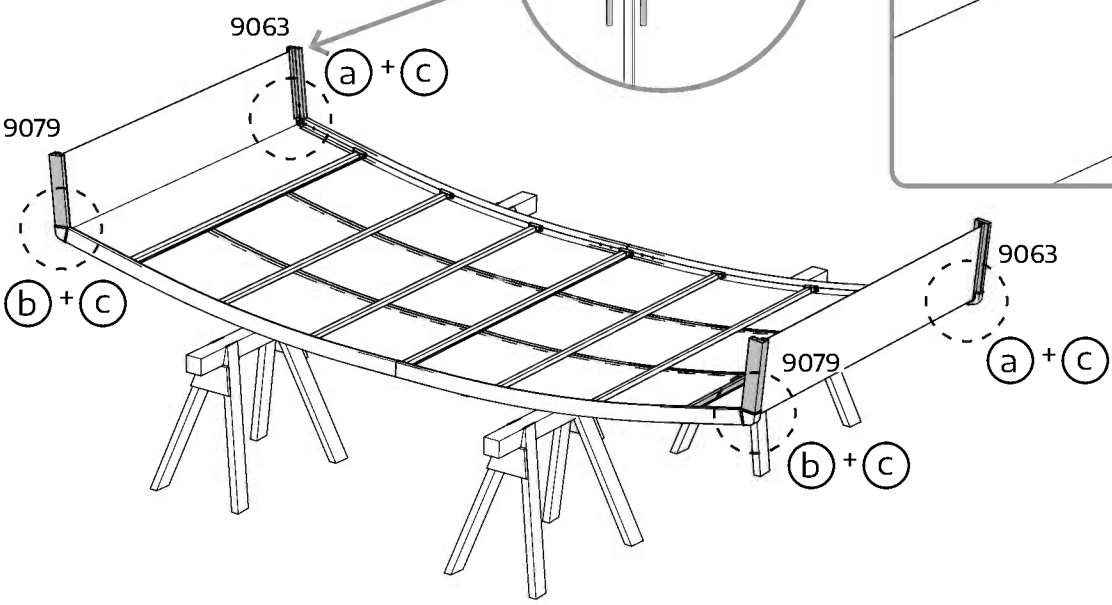
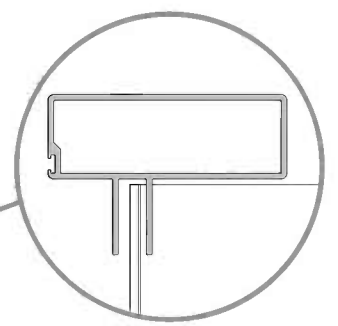
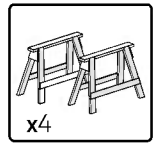
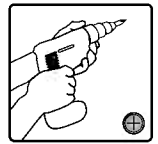

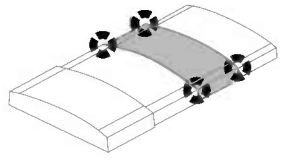

9066 8

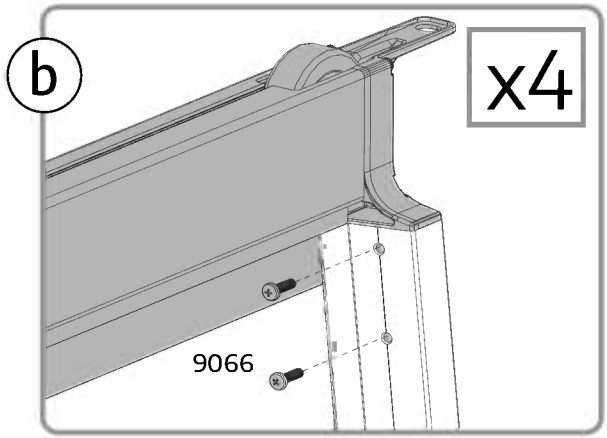
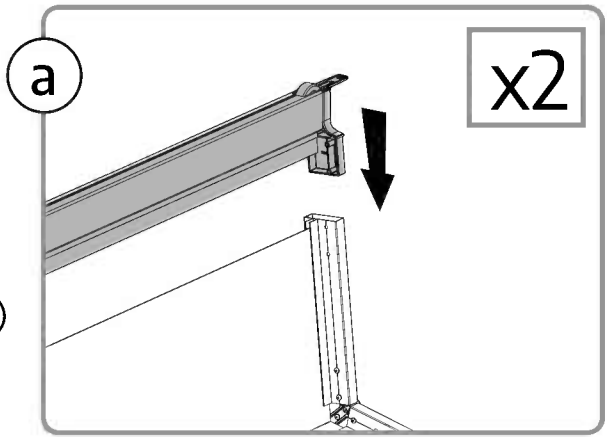
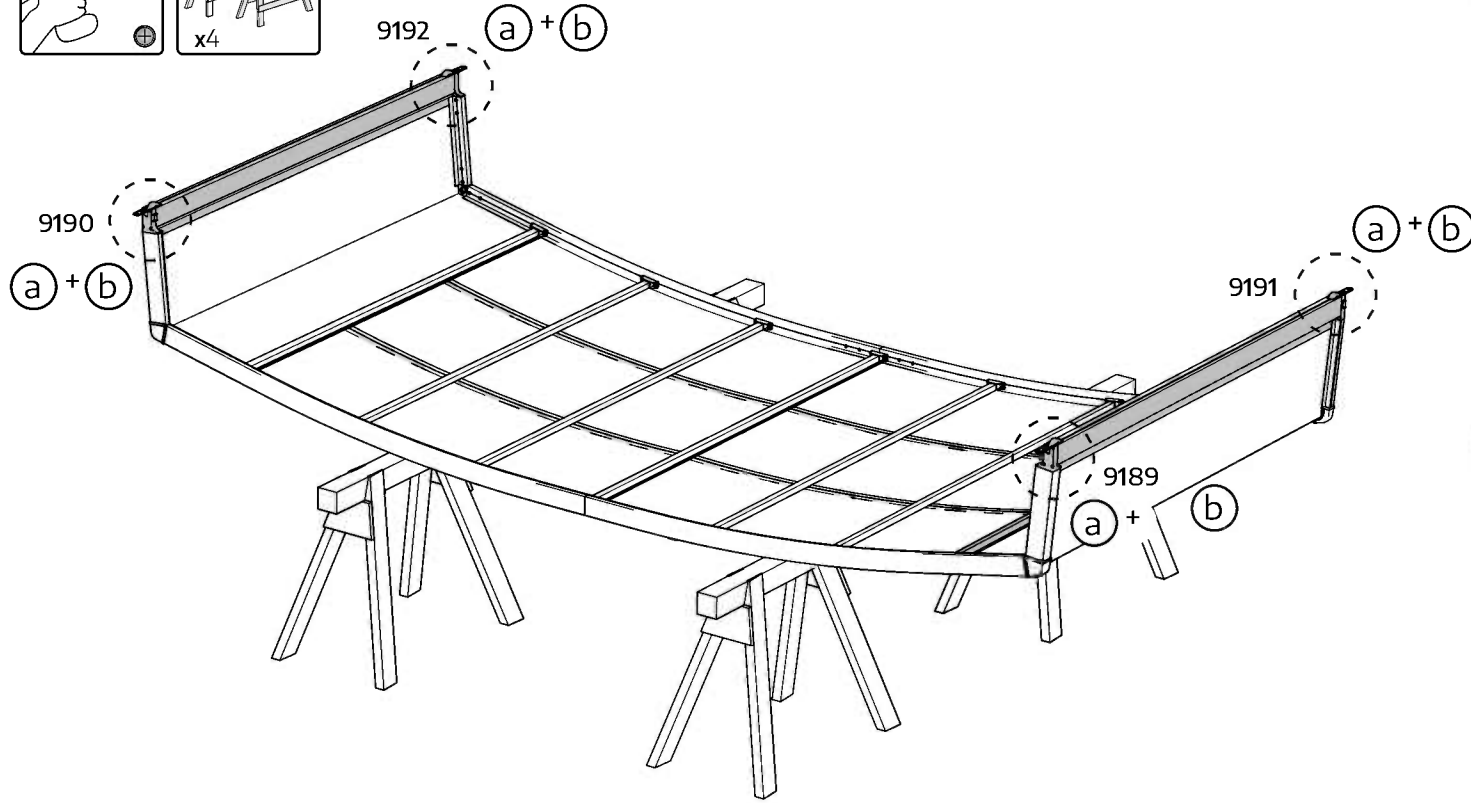
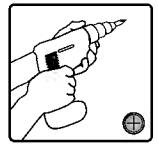
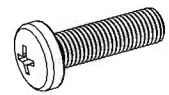

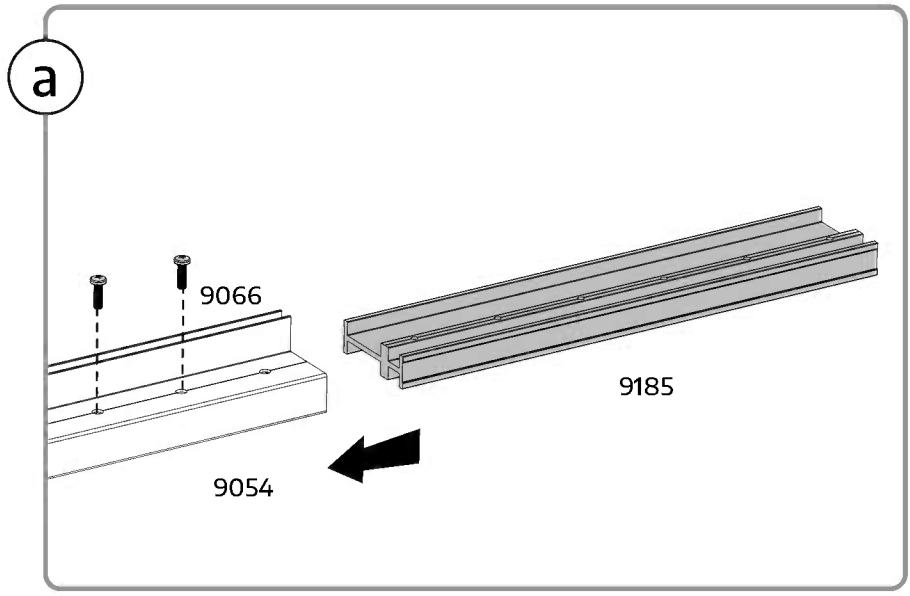
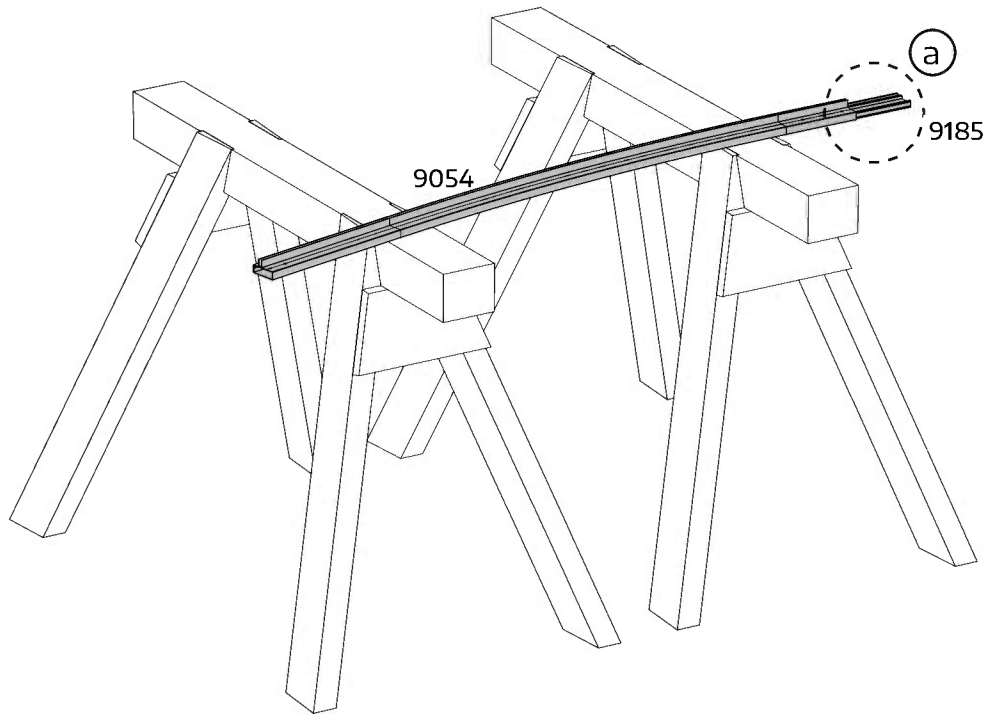
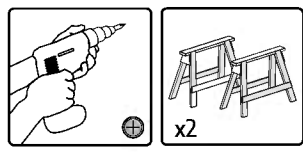
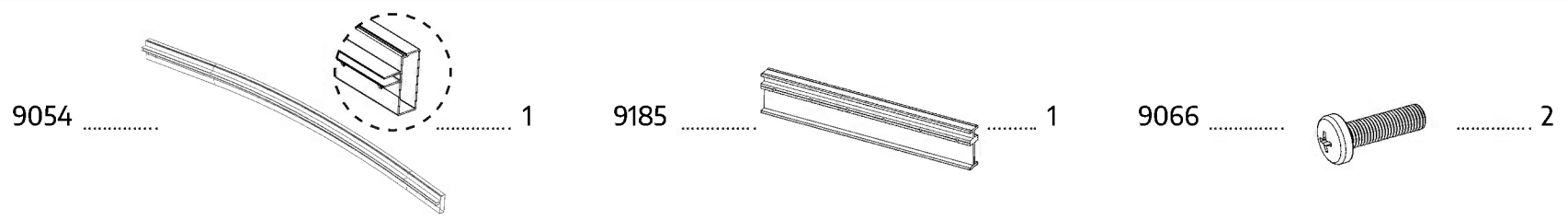
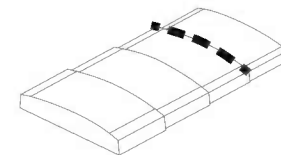

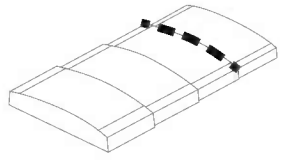

9058 1 9066 2

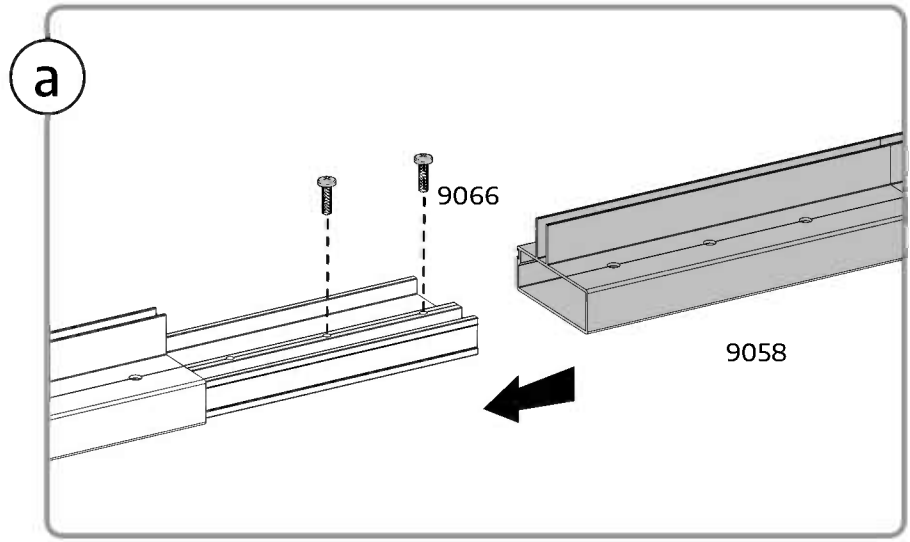
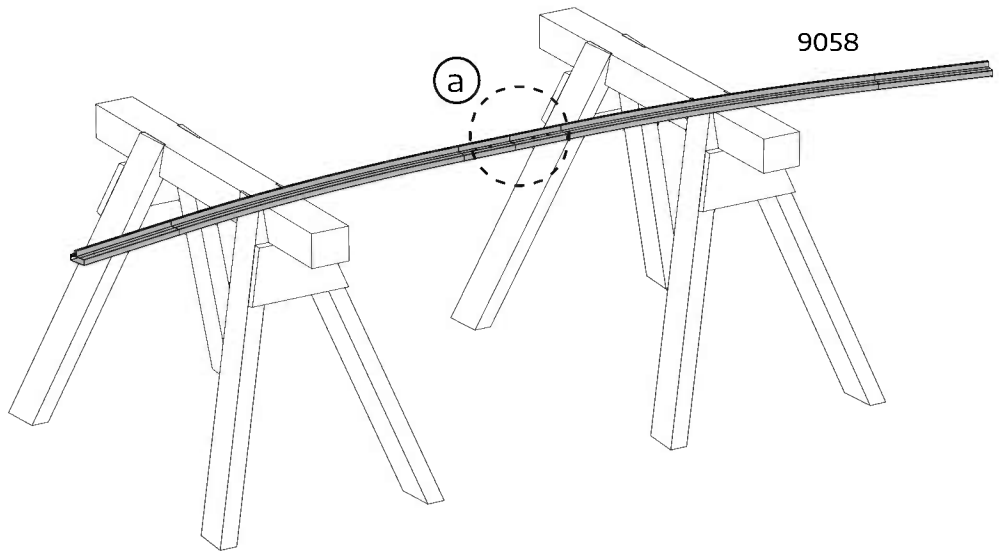
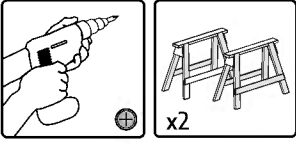

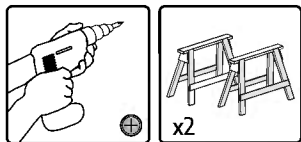
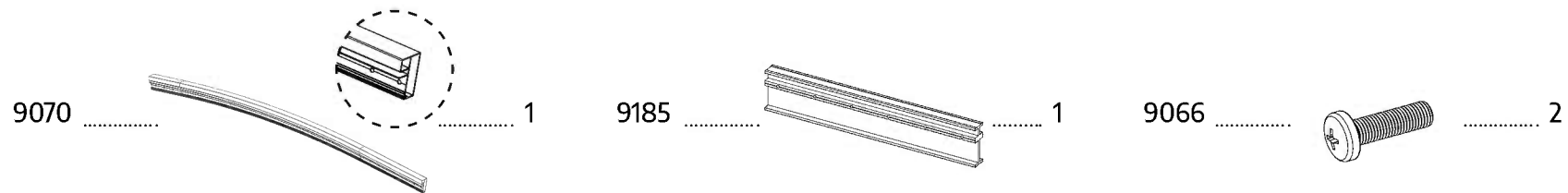
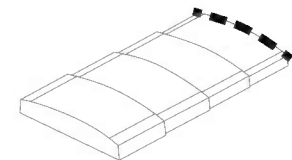

x2

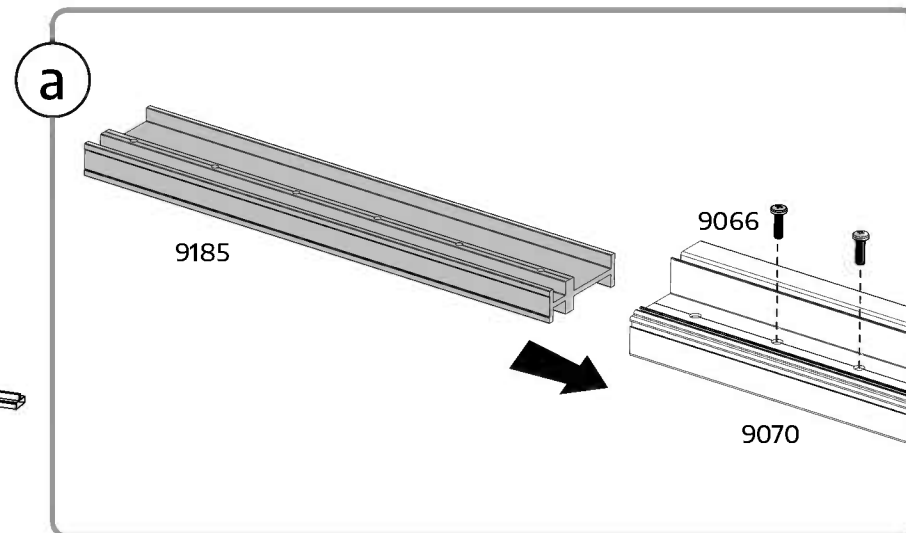
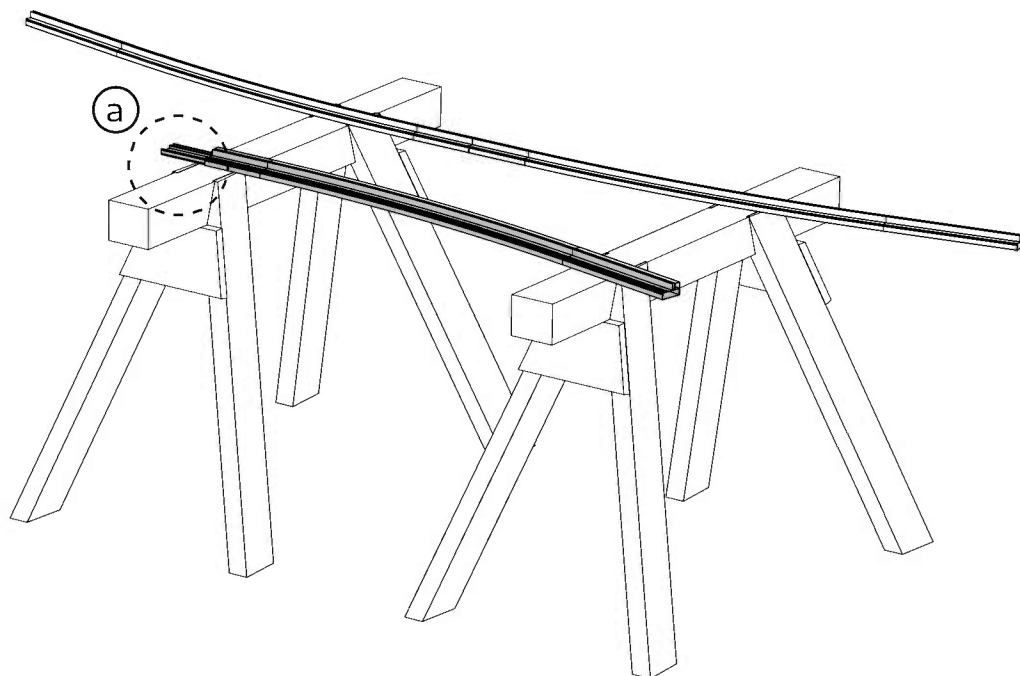

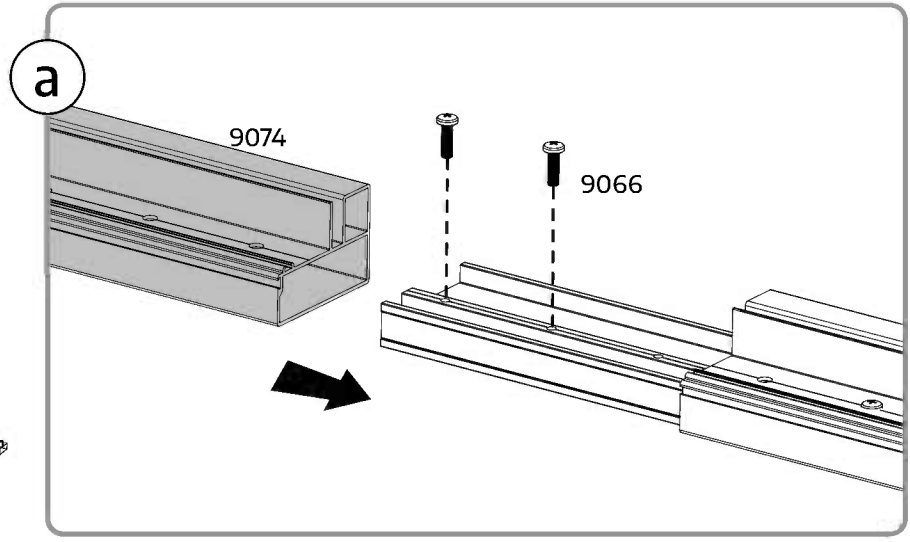
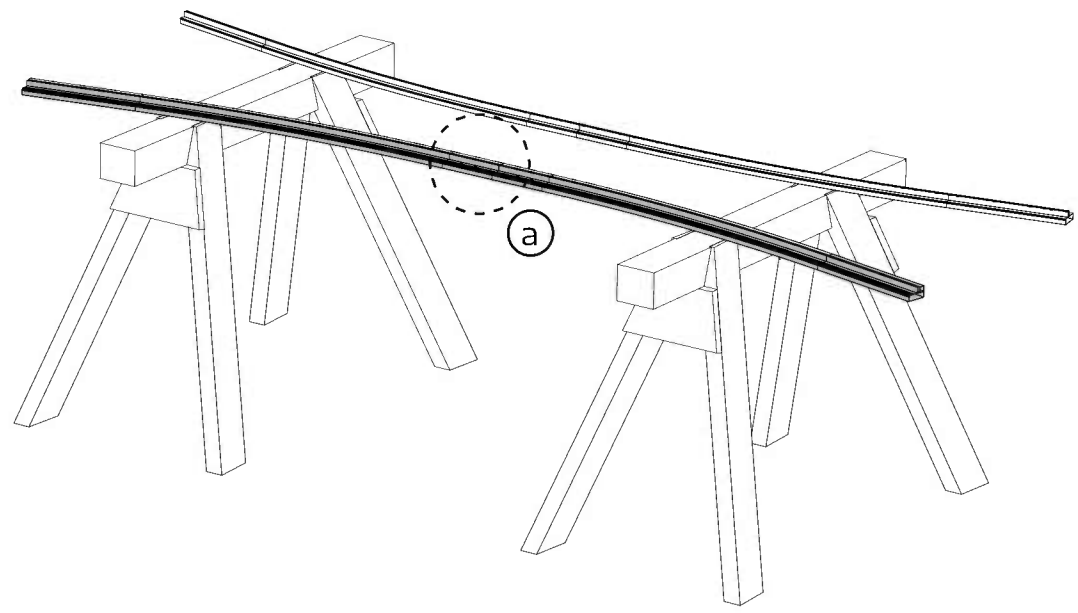
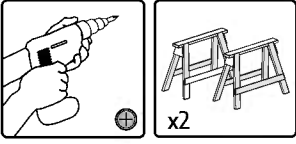
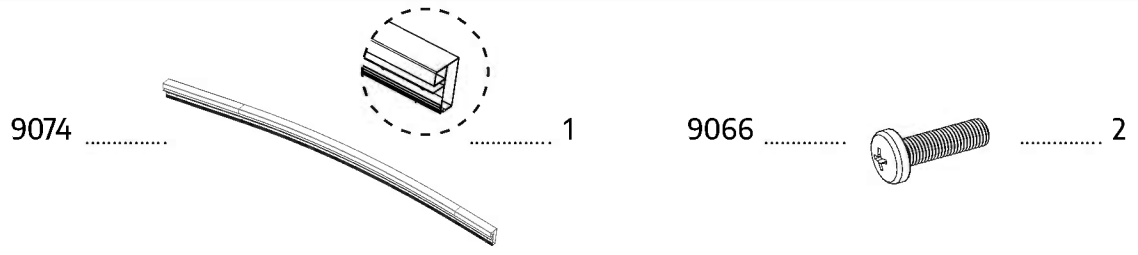
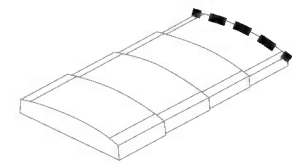

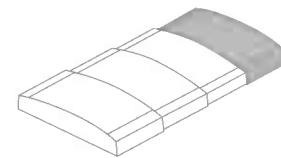

9066 4

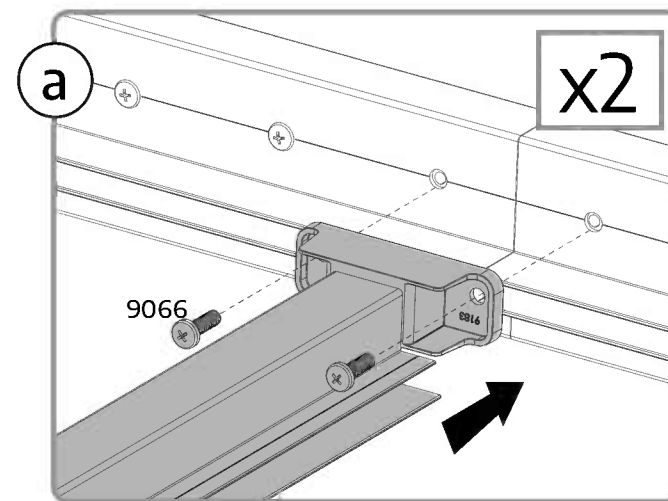
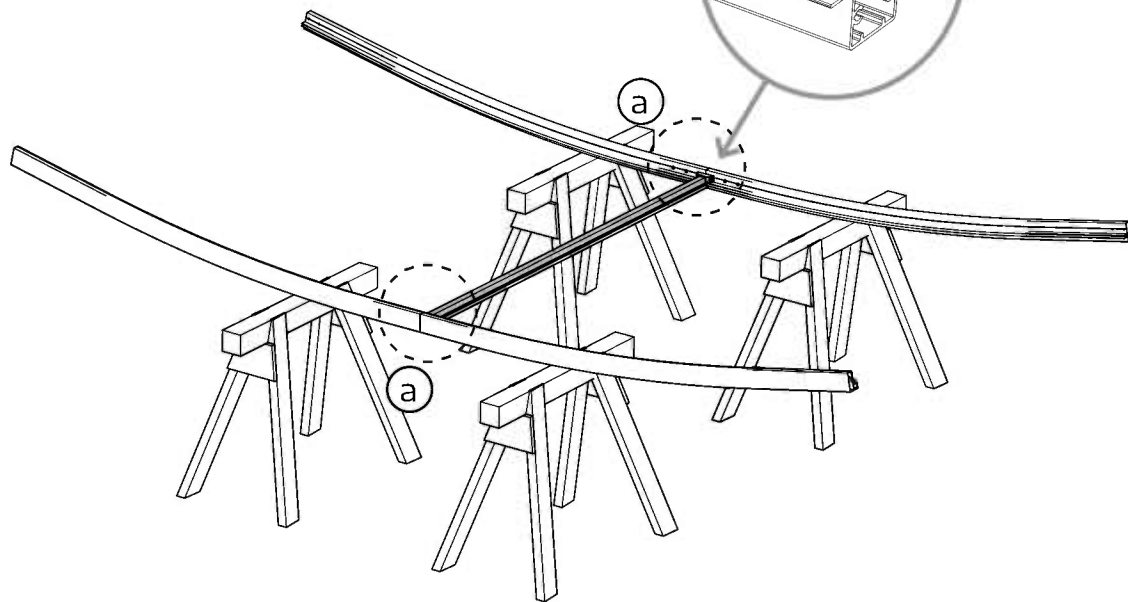
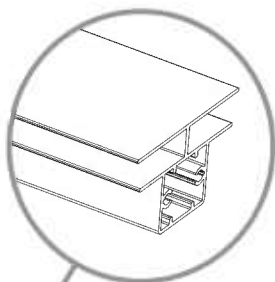
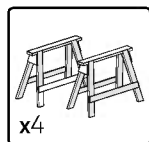
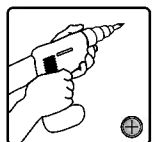
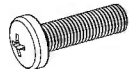

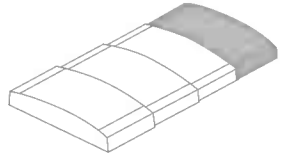

9082 16

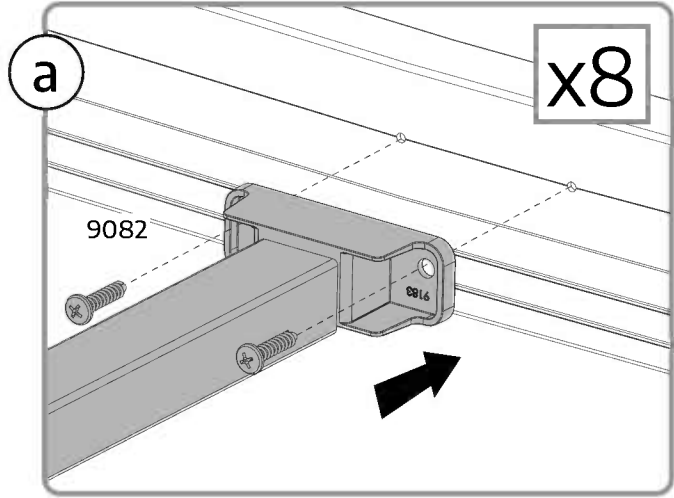
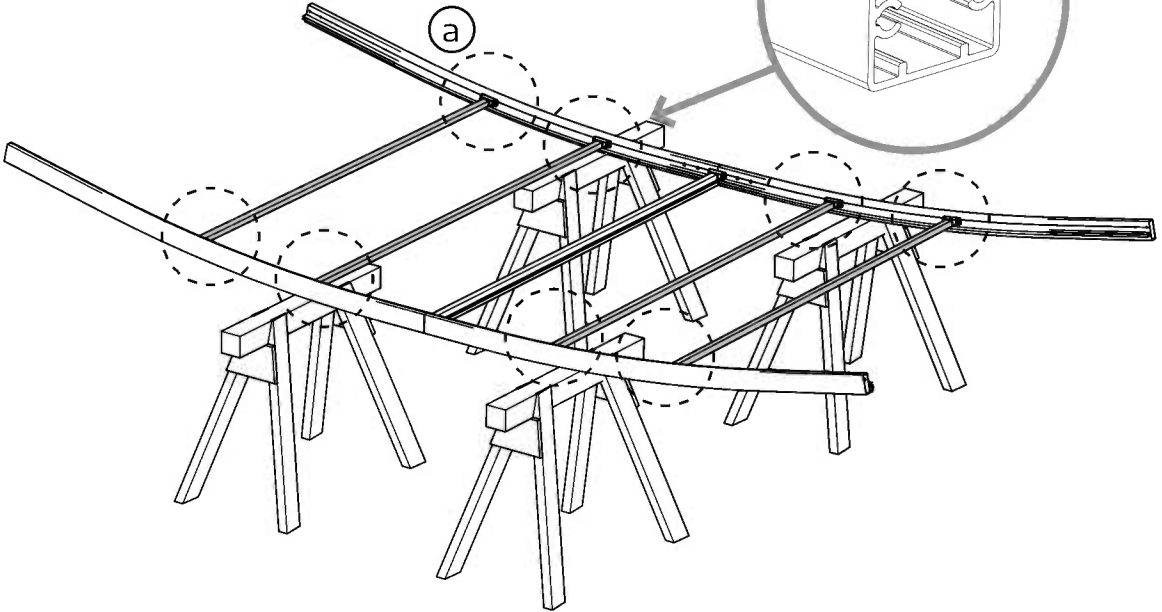
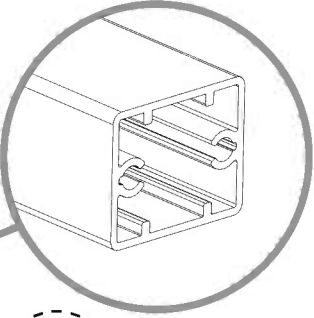
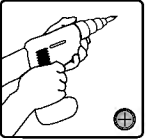
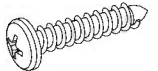

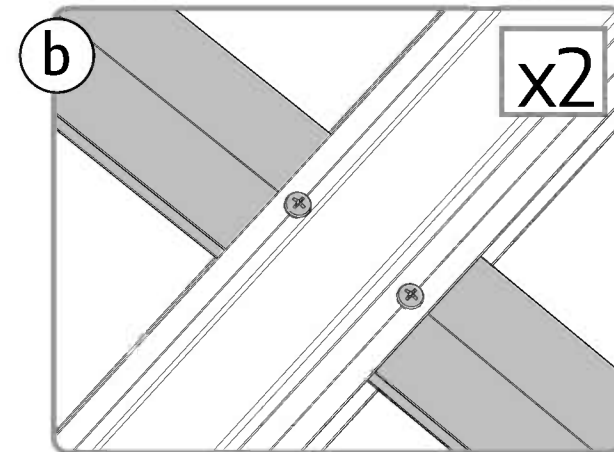
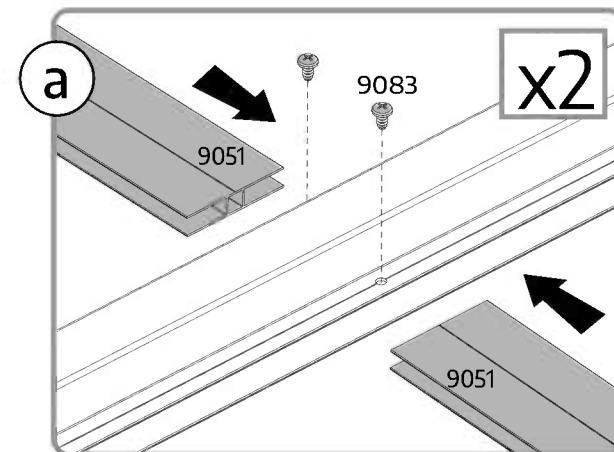
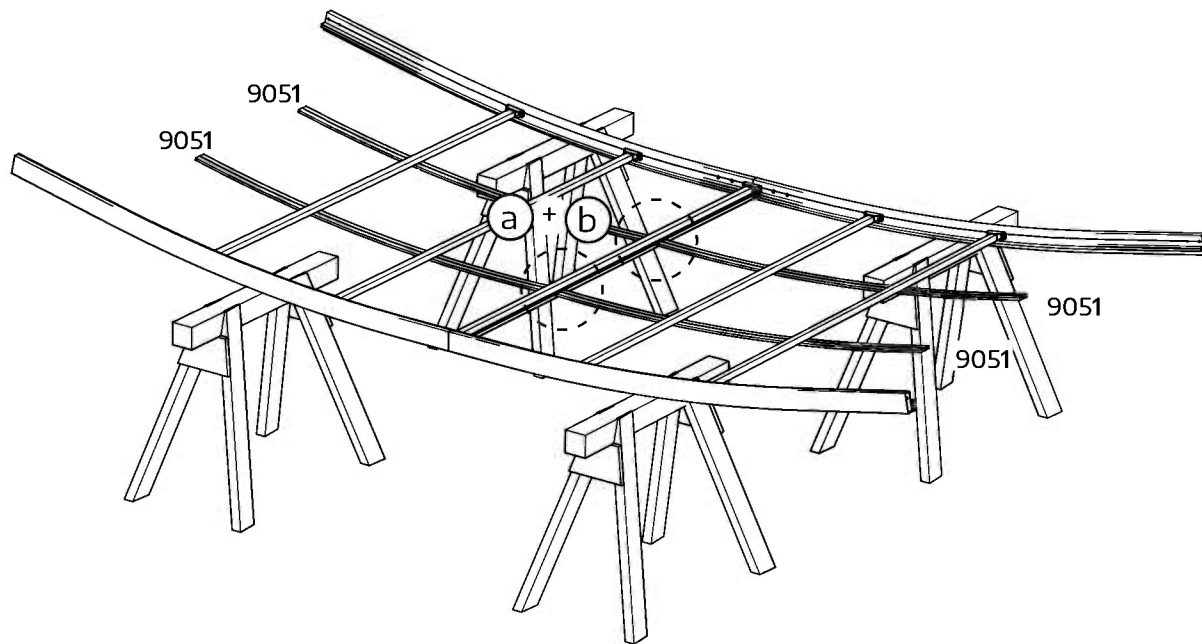
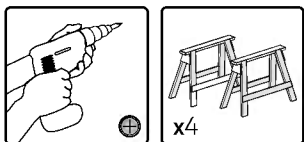
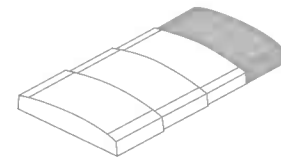

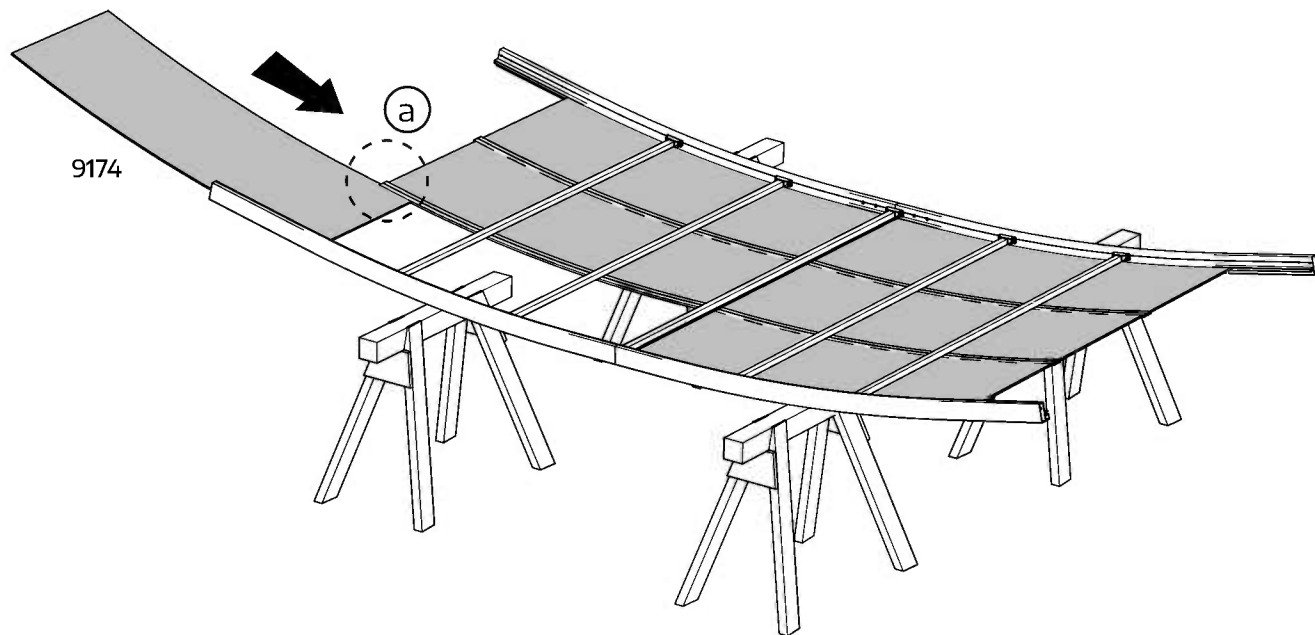
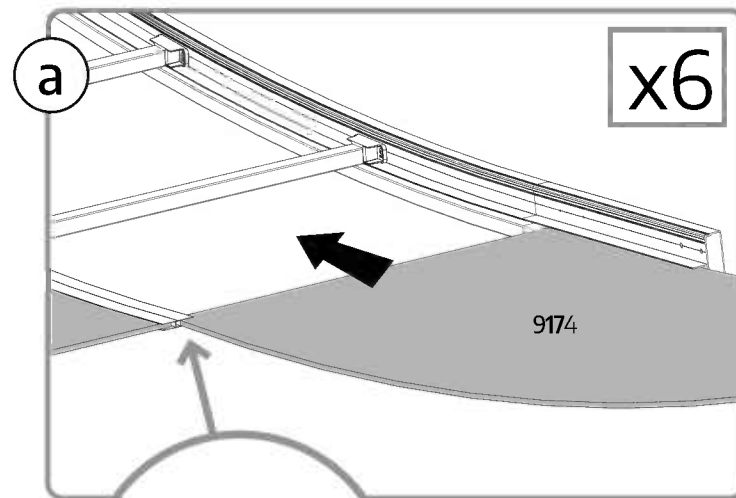
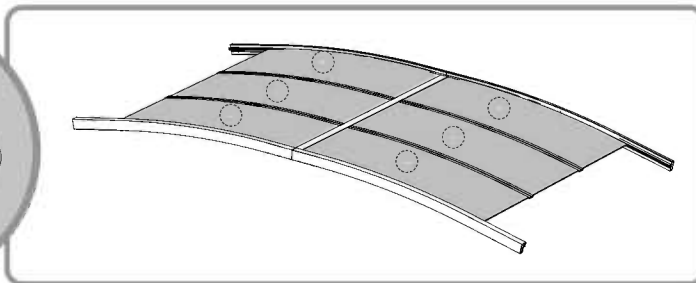
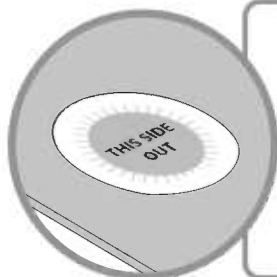
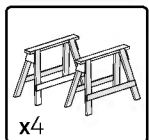
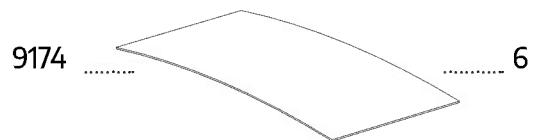
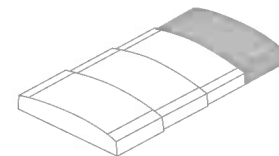

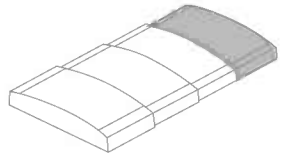

9082 8

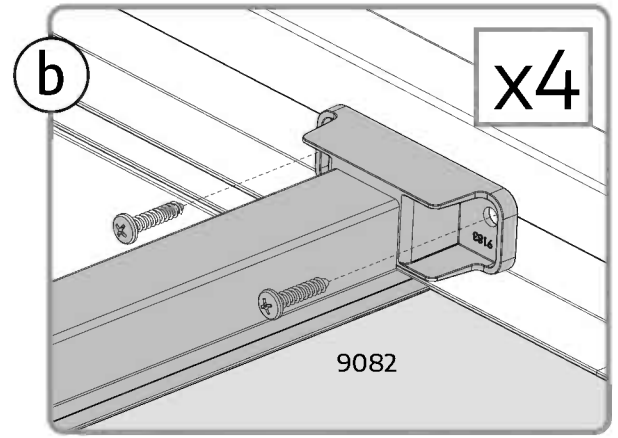
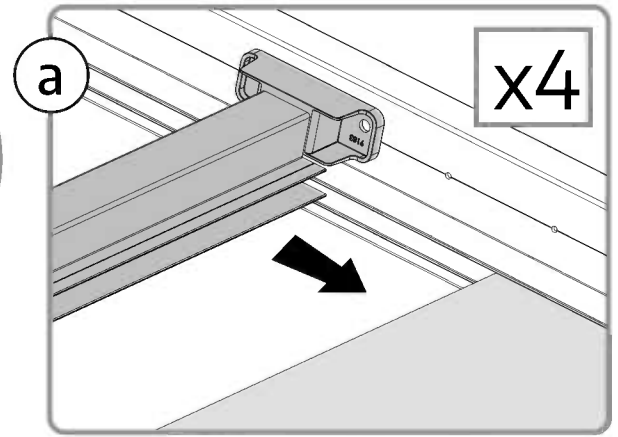
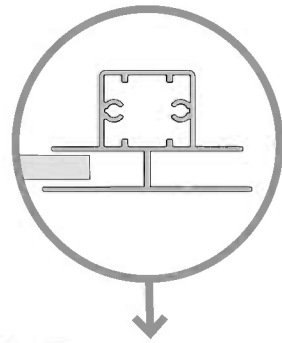
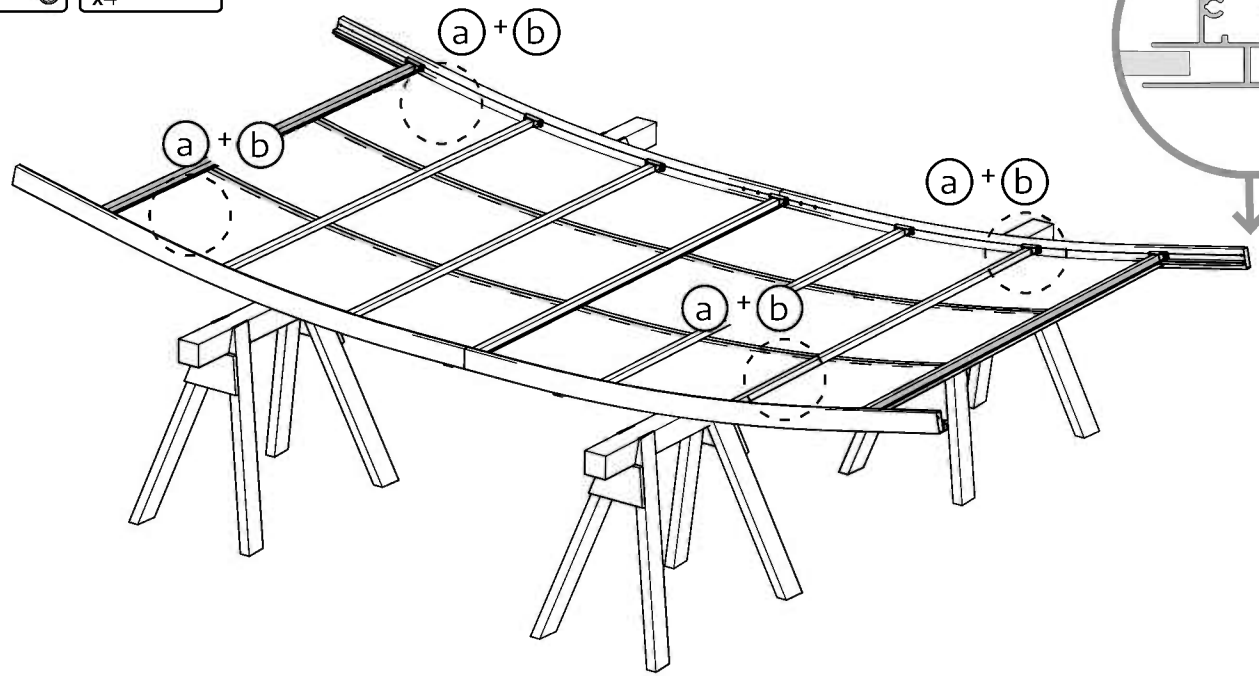
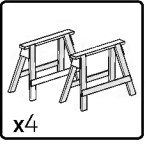
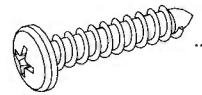

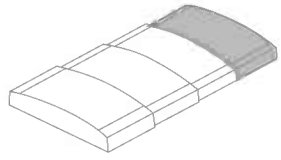

9083 4

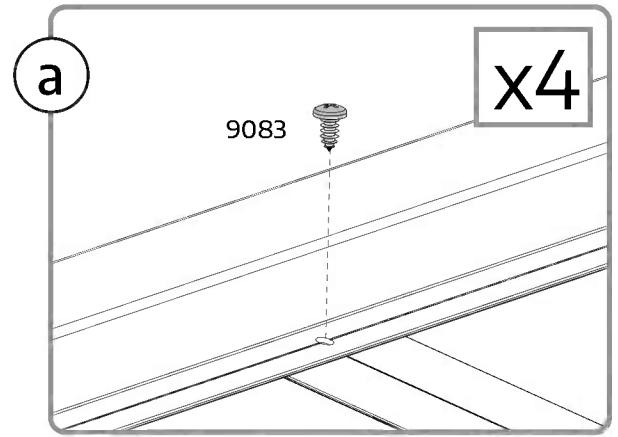
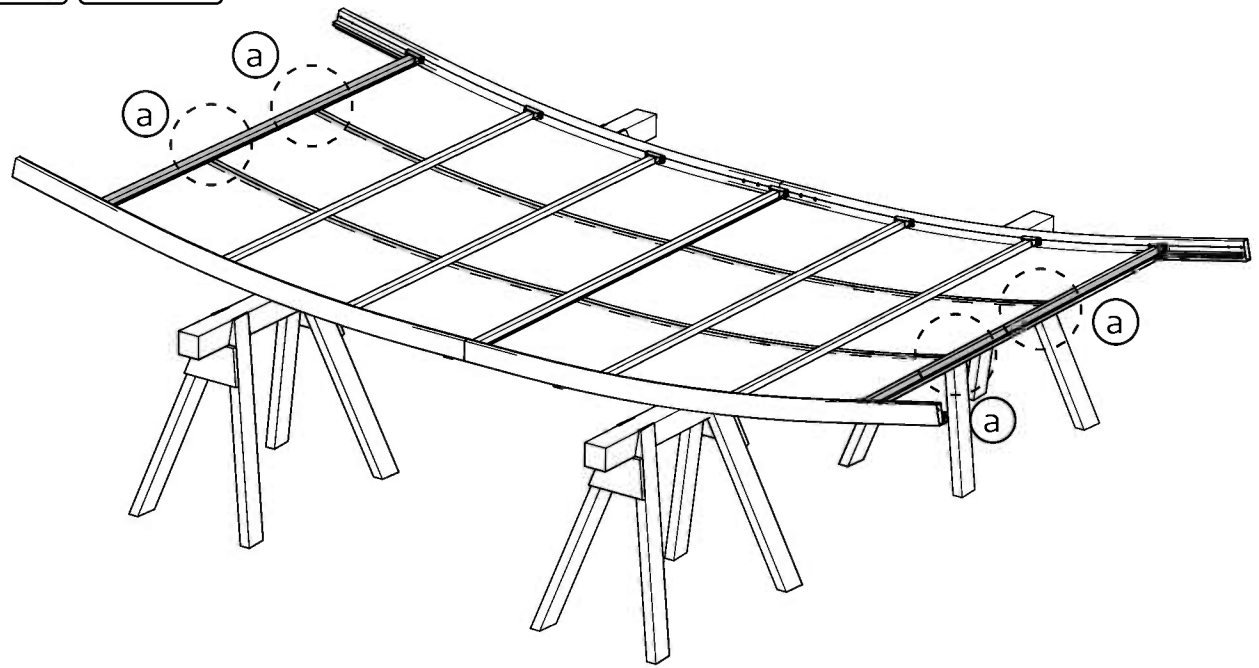
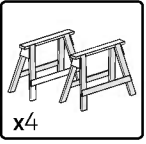
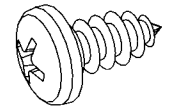

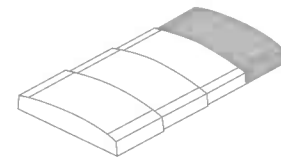

9175 2

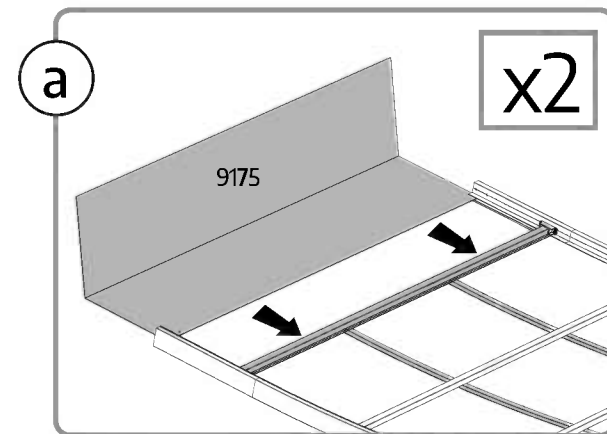
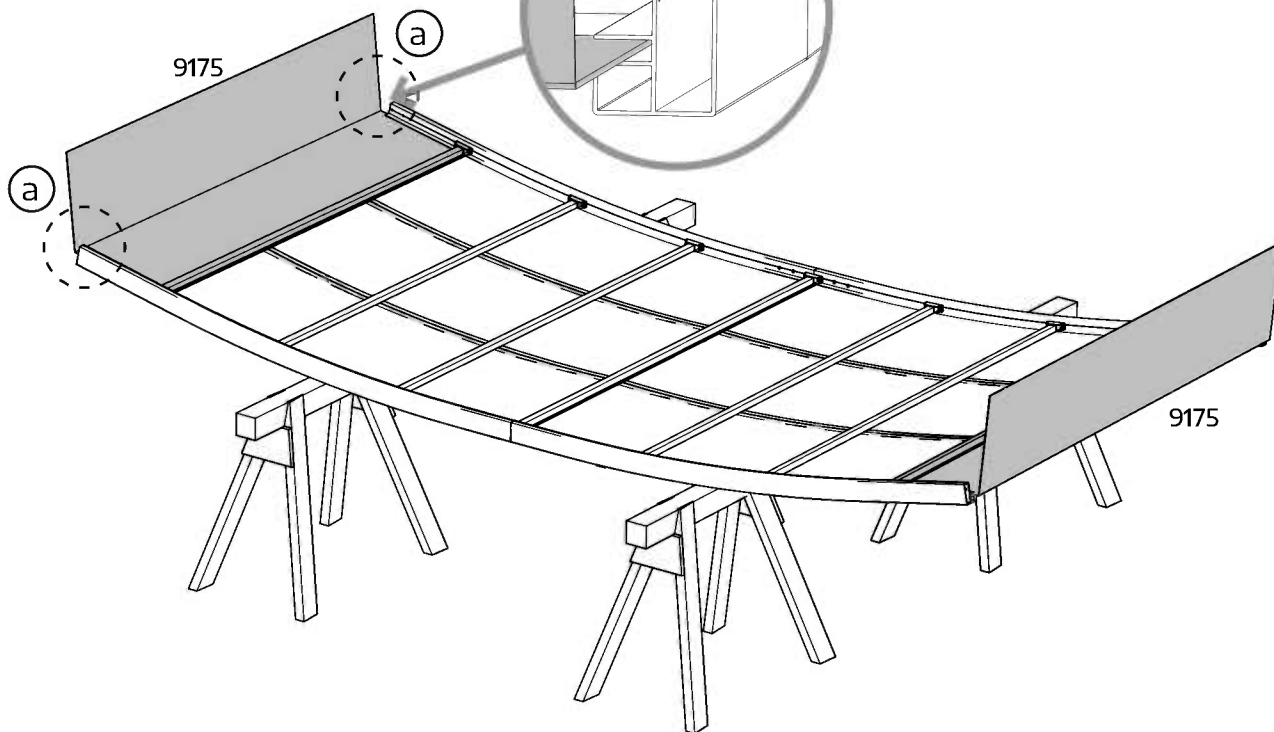
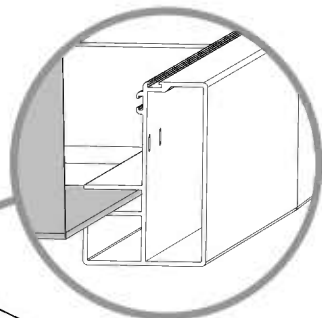
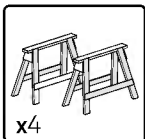
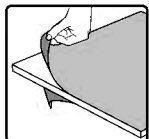
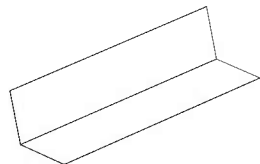

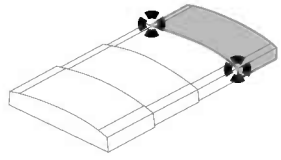

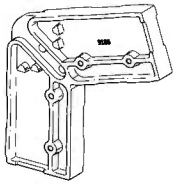
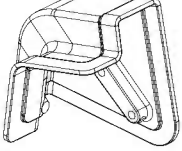
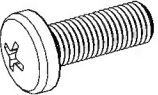
- 9186 2 9188 2 9067 4
- 
- 
- 

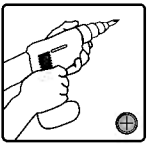

x2

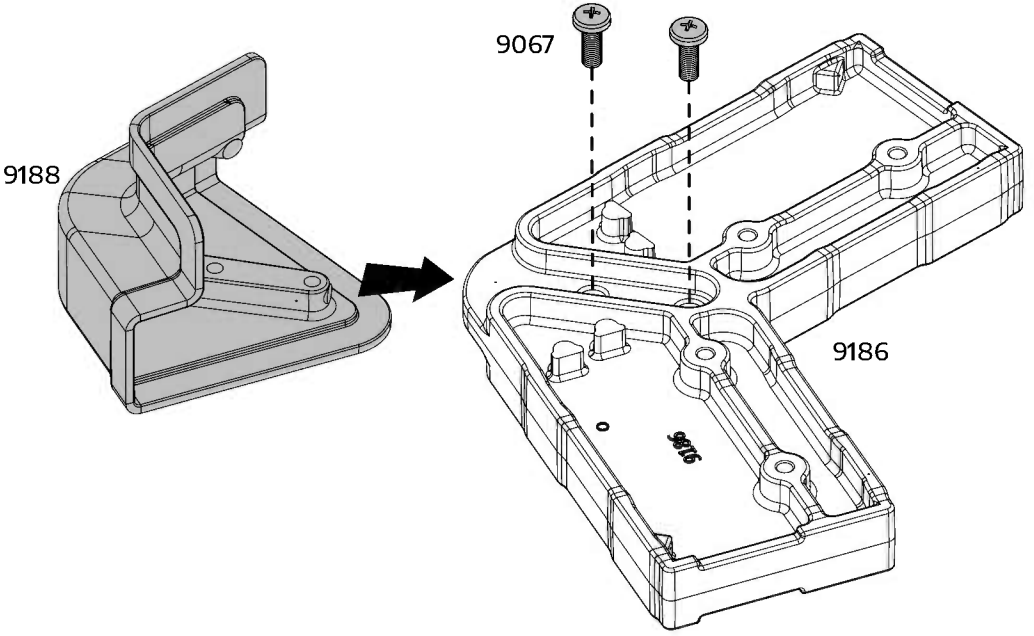

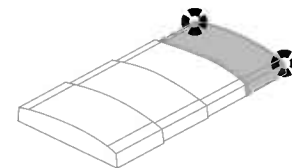

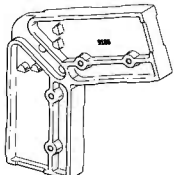
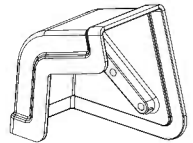
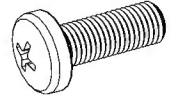
- 9186 2 9187 2 9067 4
- 
- 
- 

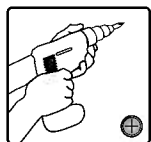

x2

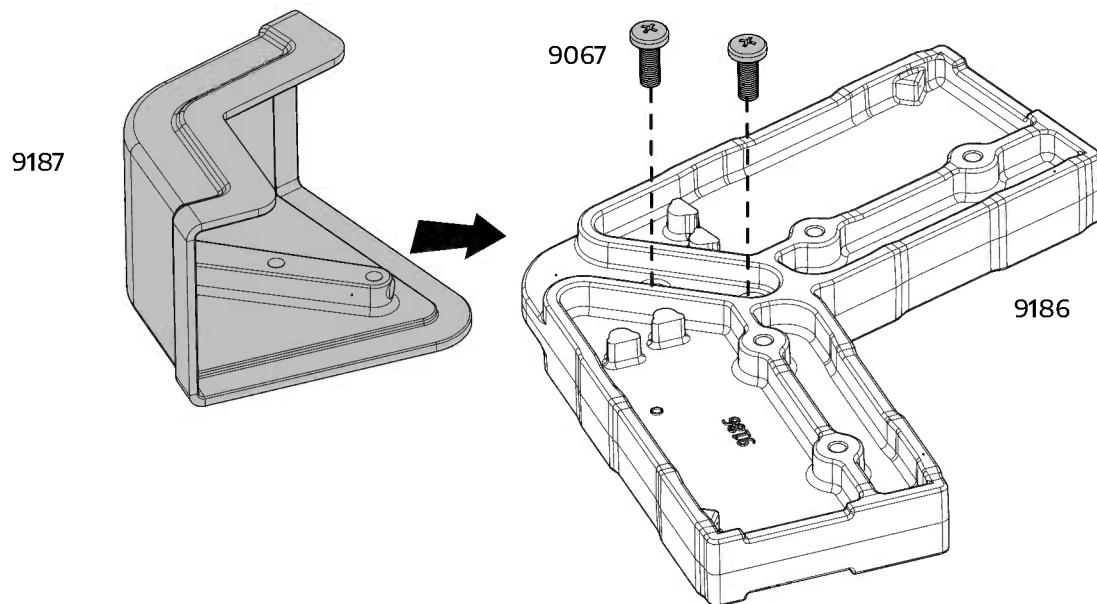

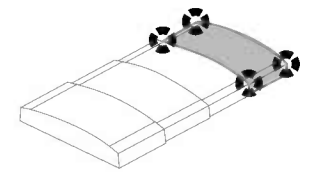

9066 8

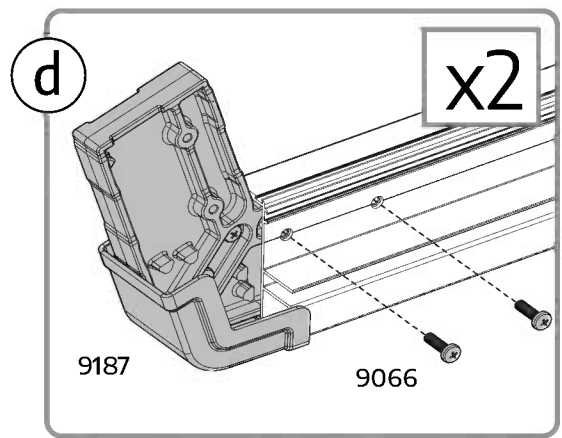
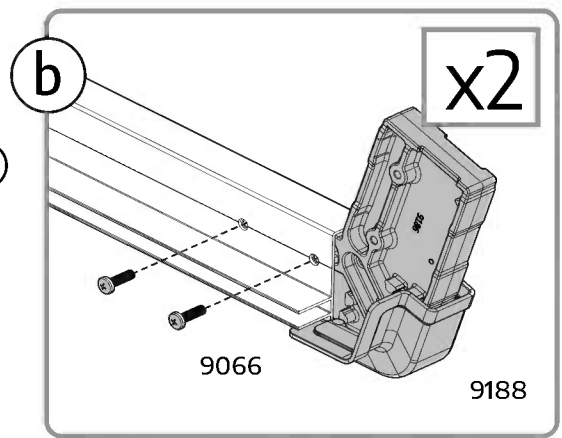
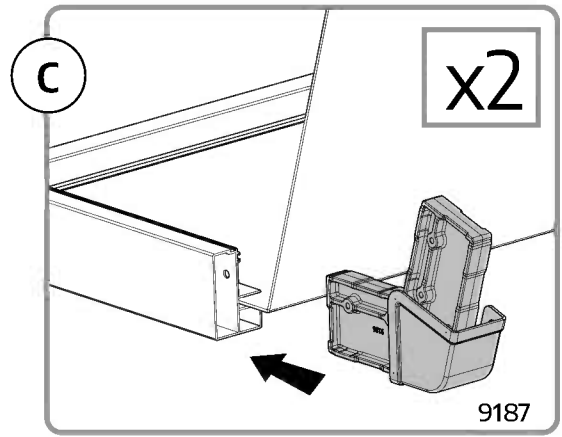
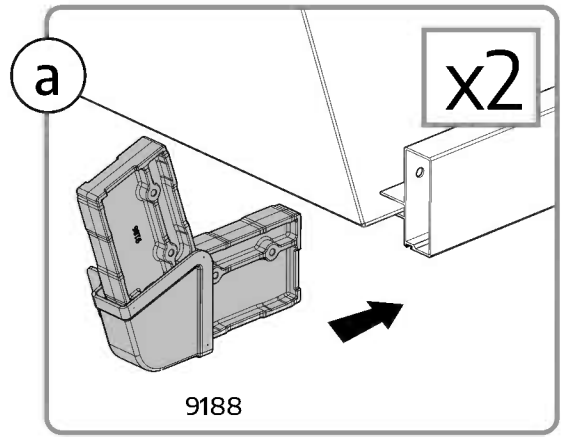
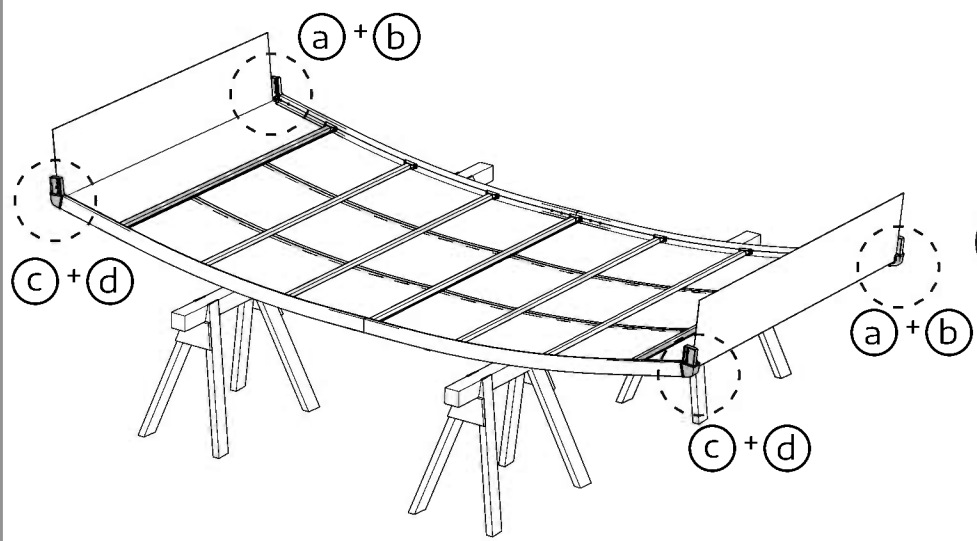
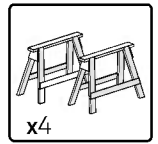
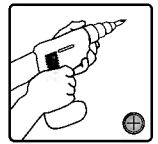
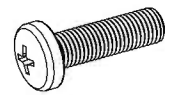

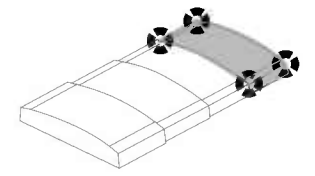

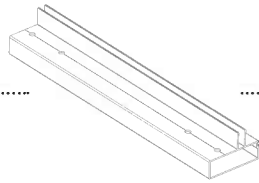
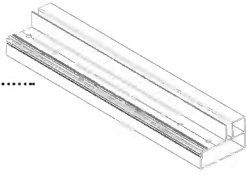
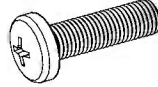
- 9062 2 9078 2 9066 8
- 
- 
- 

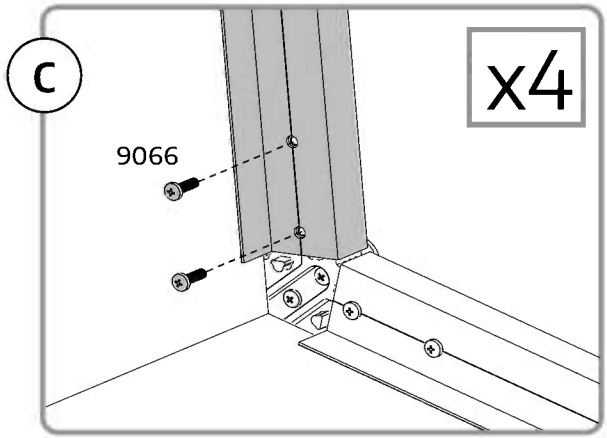
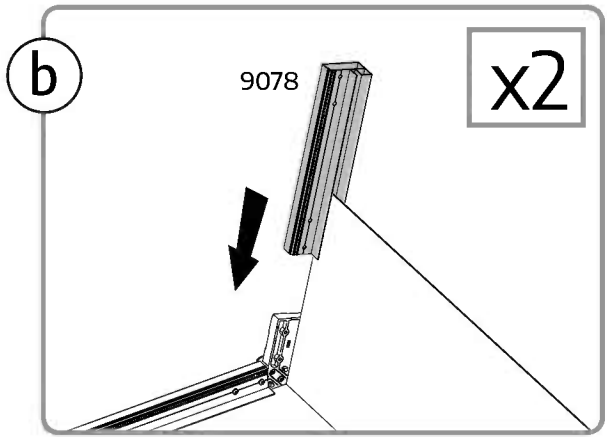
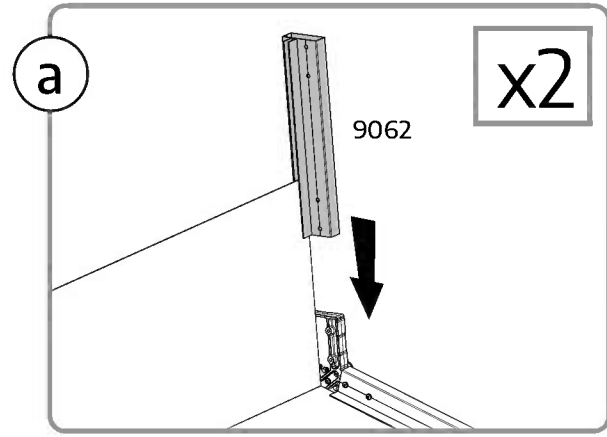
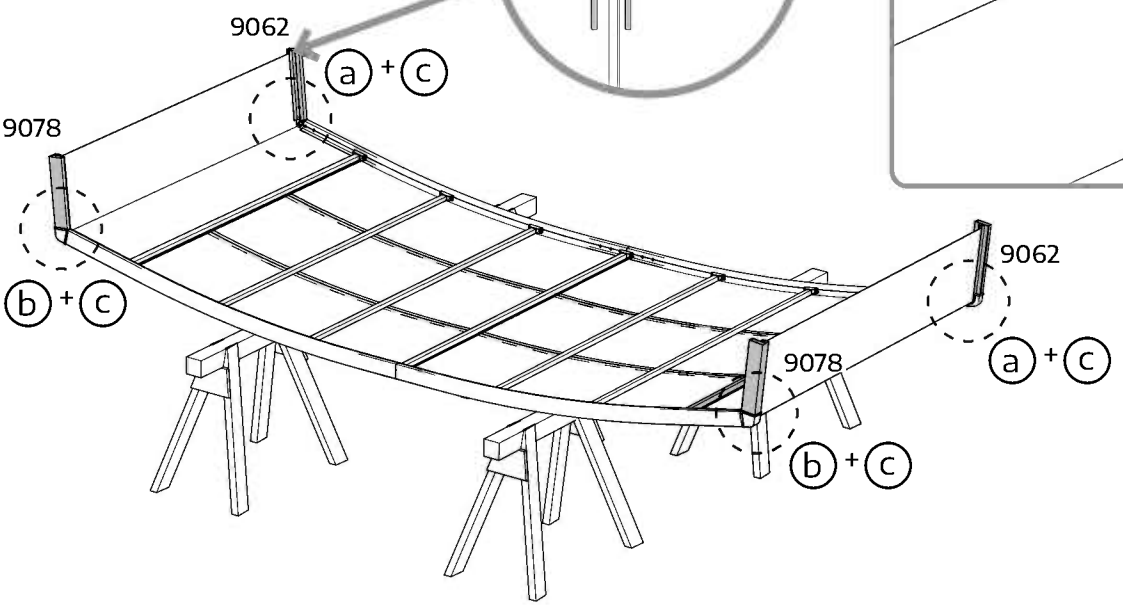
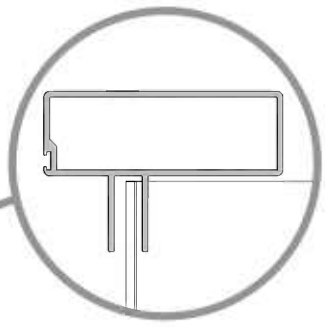
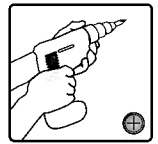

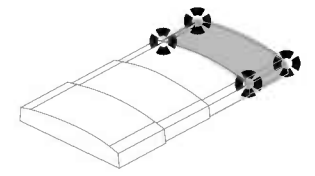

9066 8

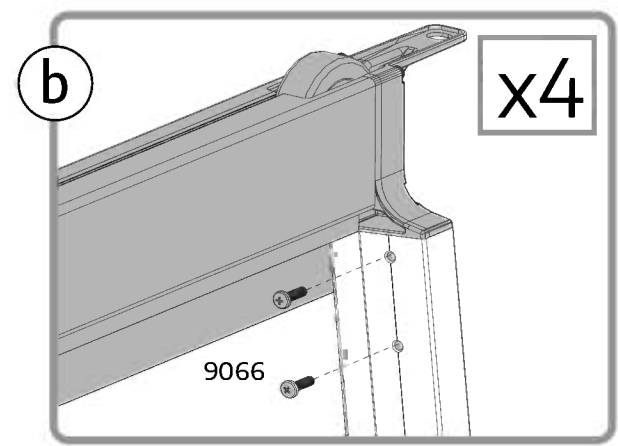
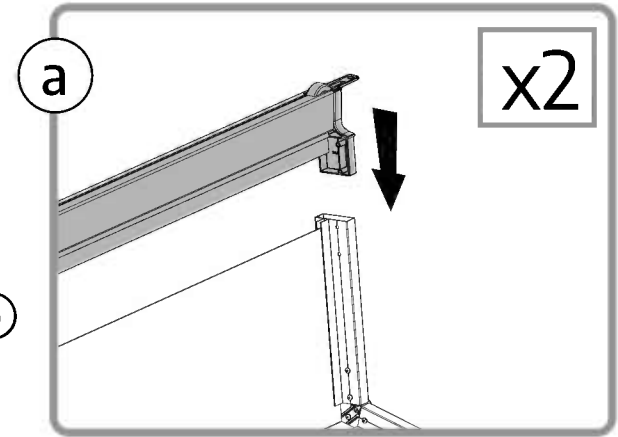
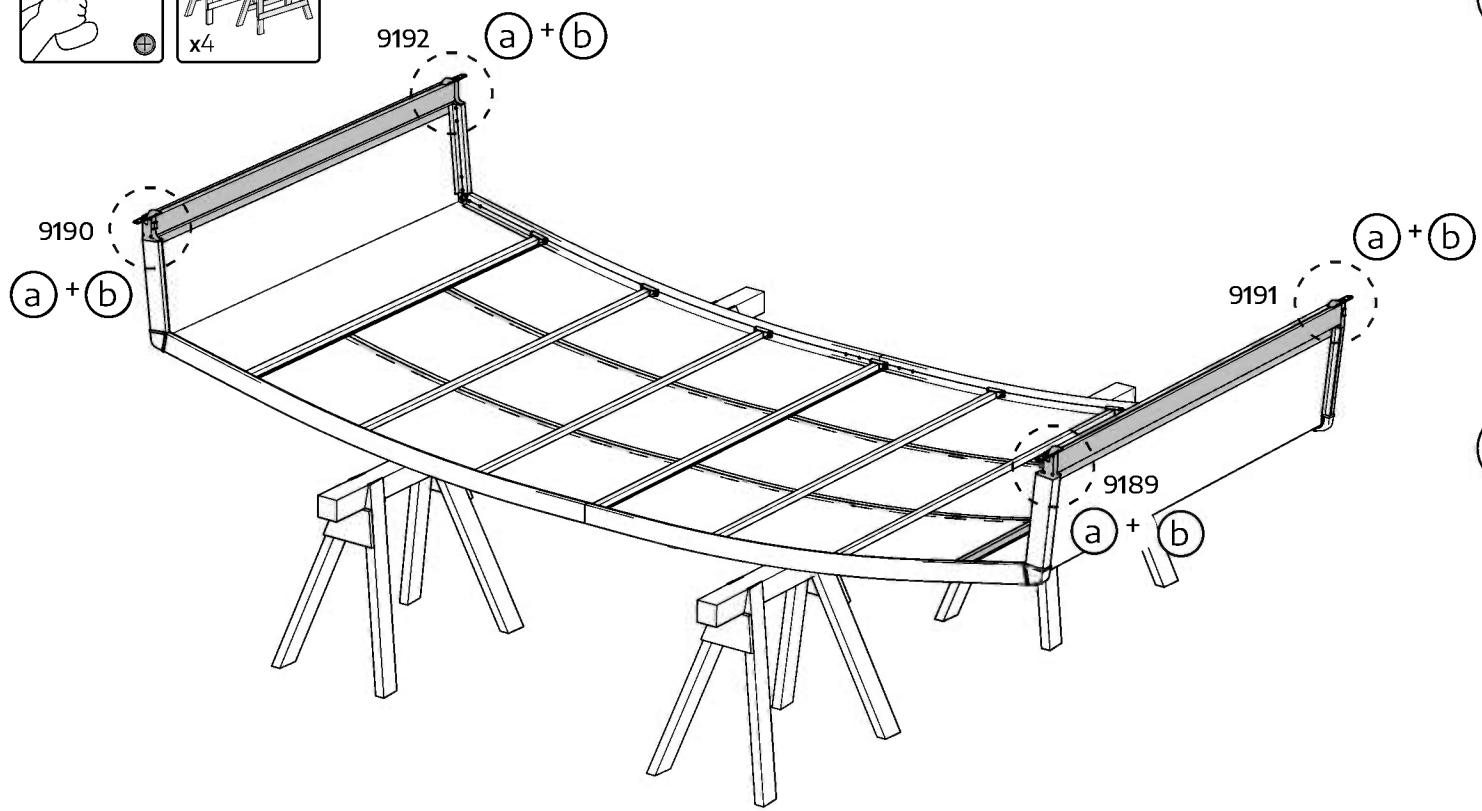
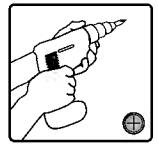
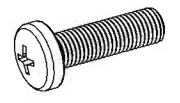

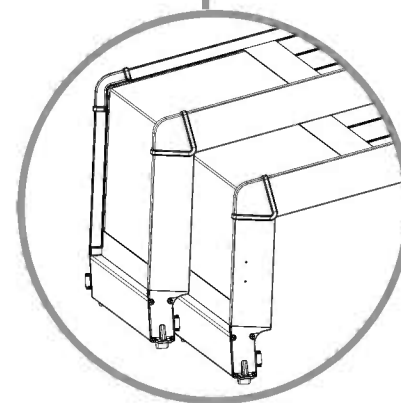
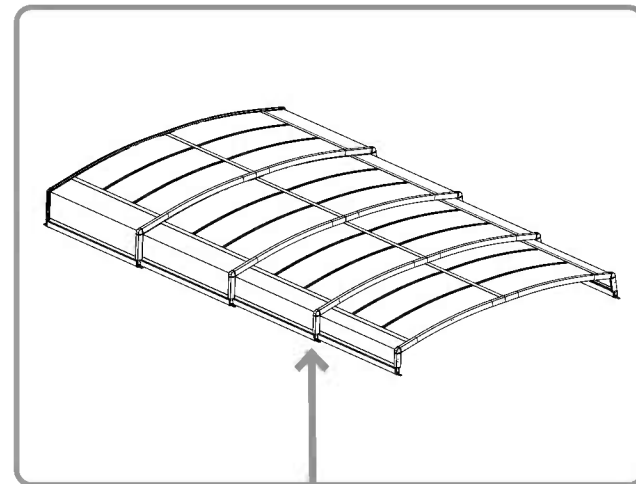
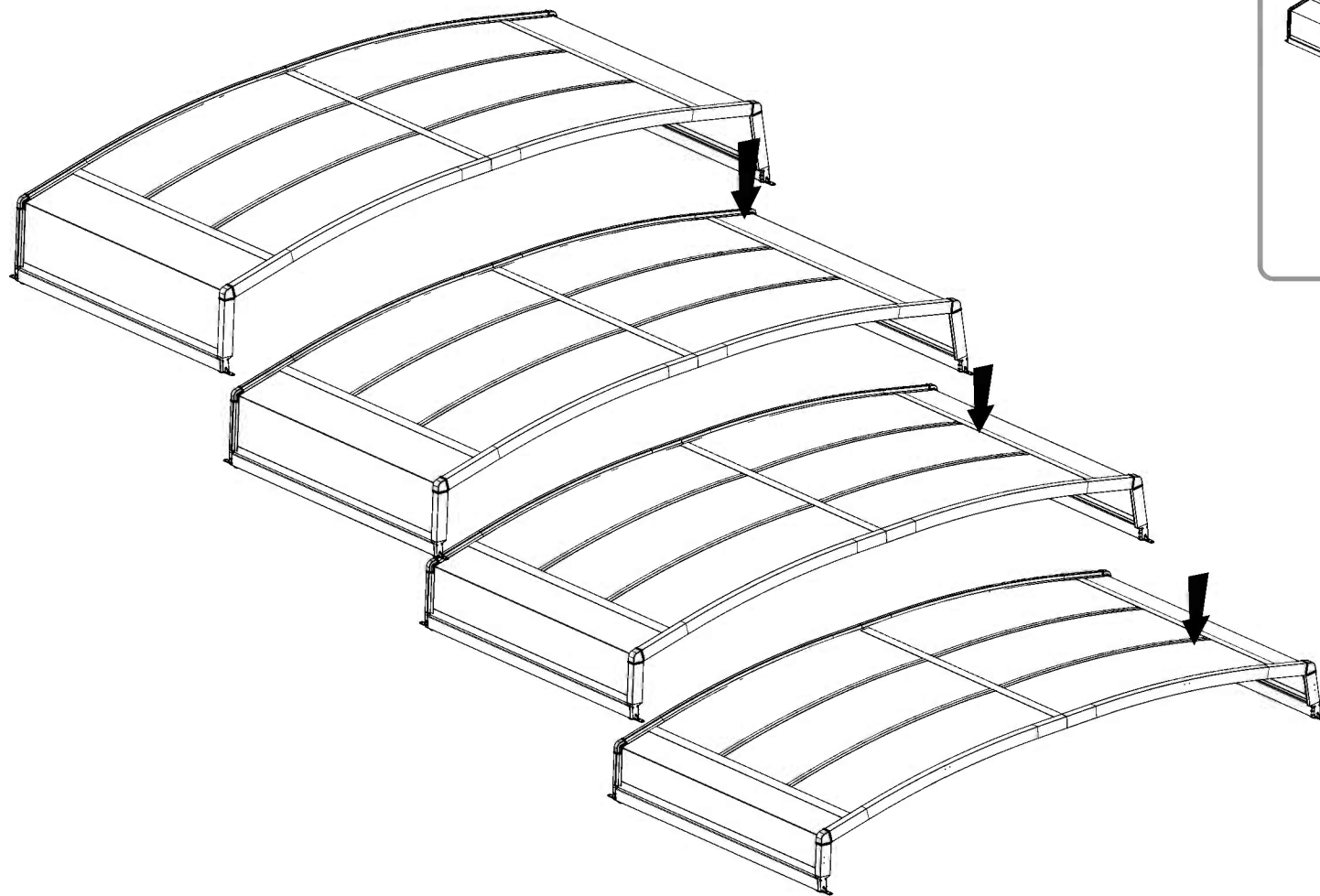
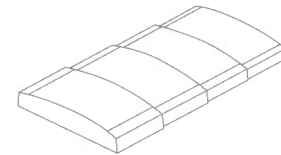

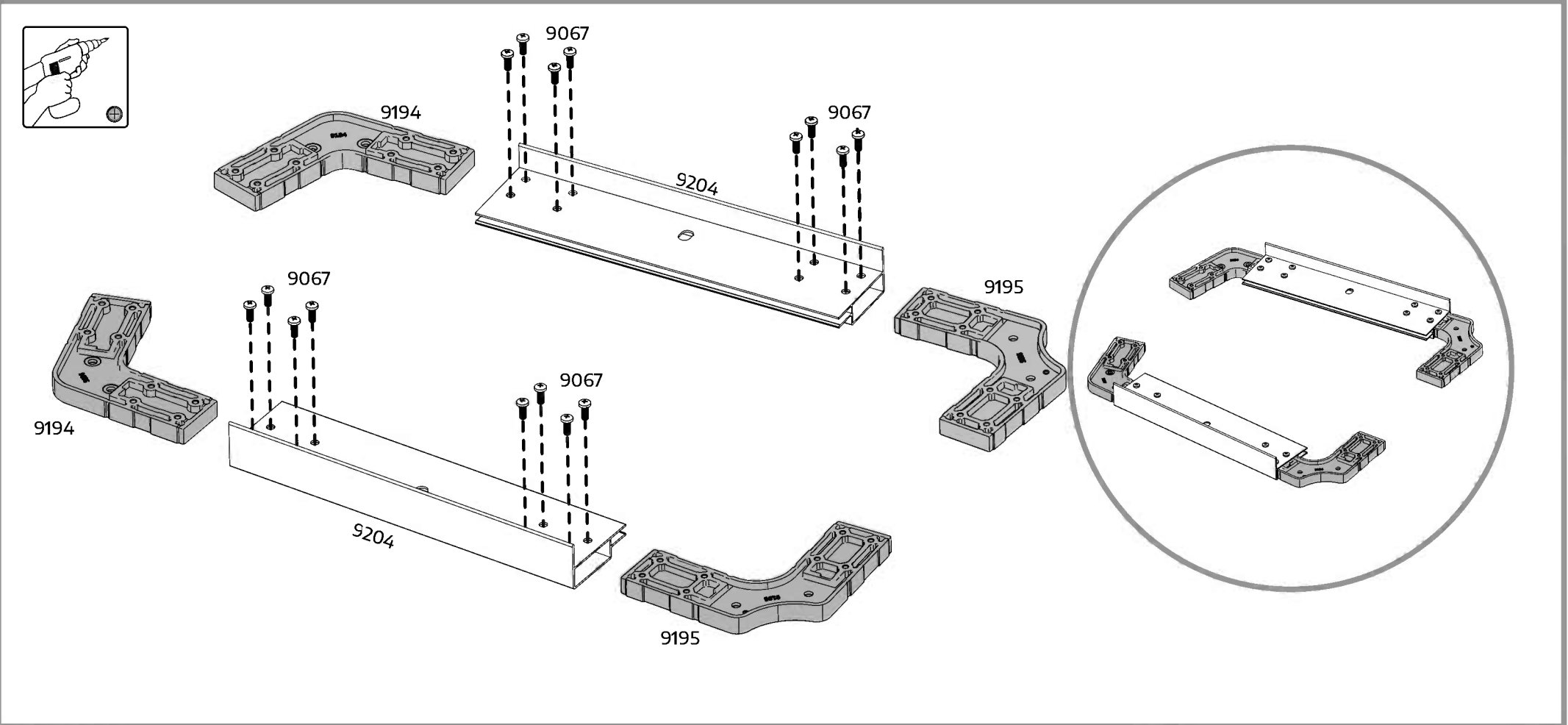
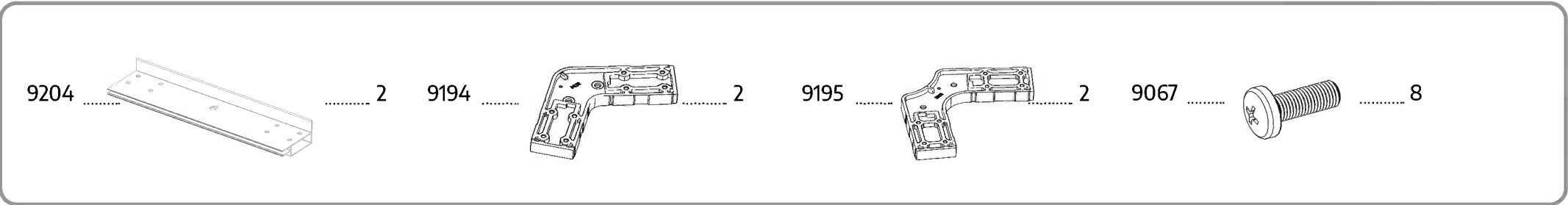
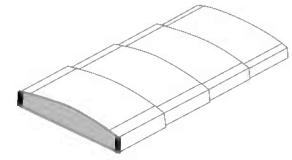

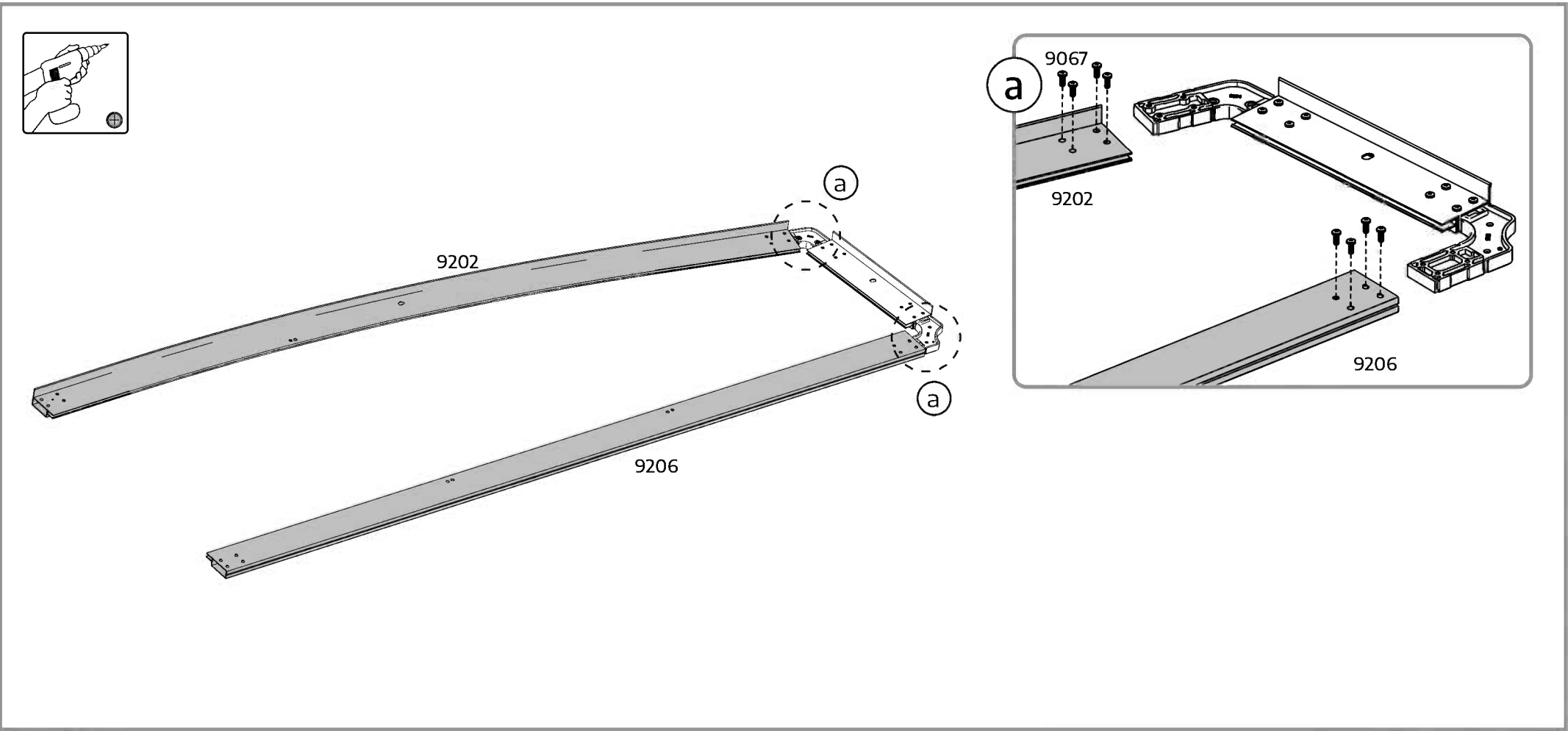
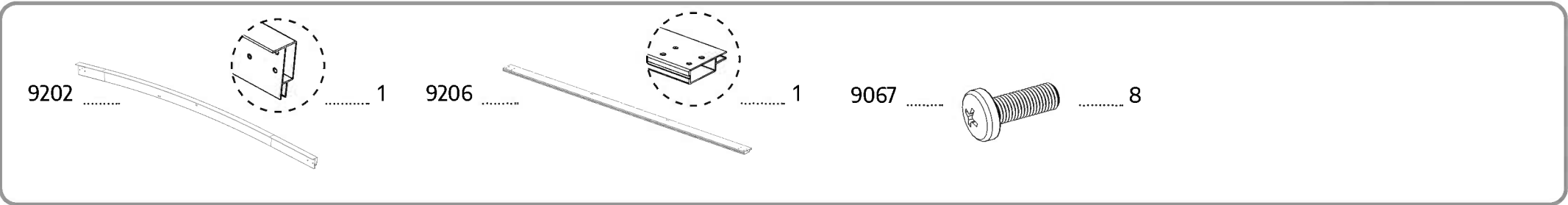
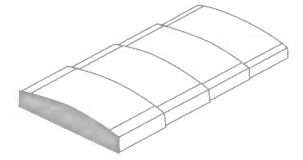

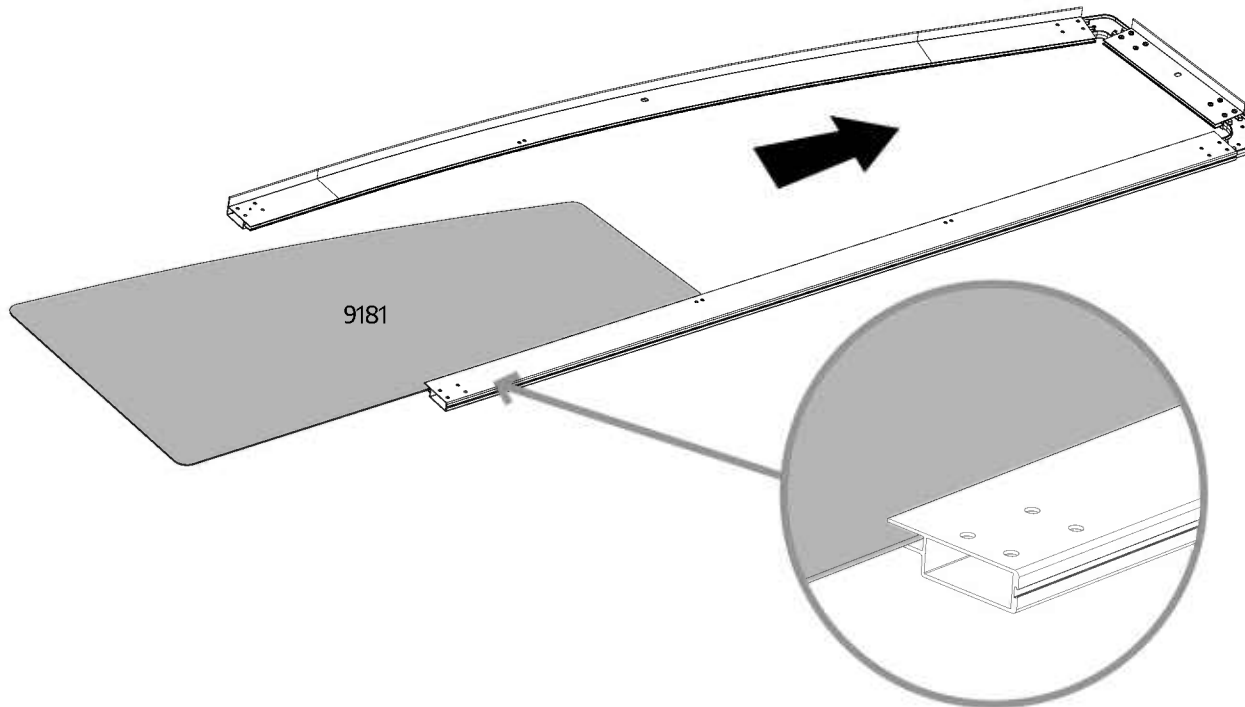
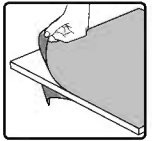
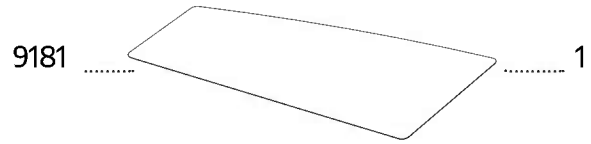
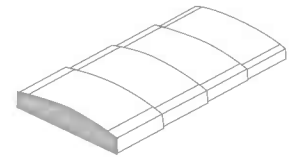

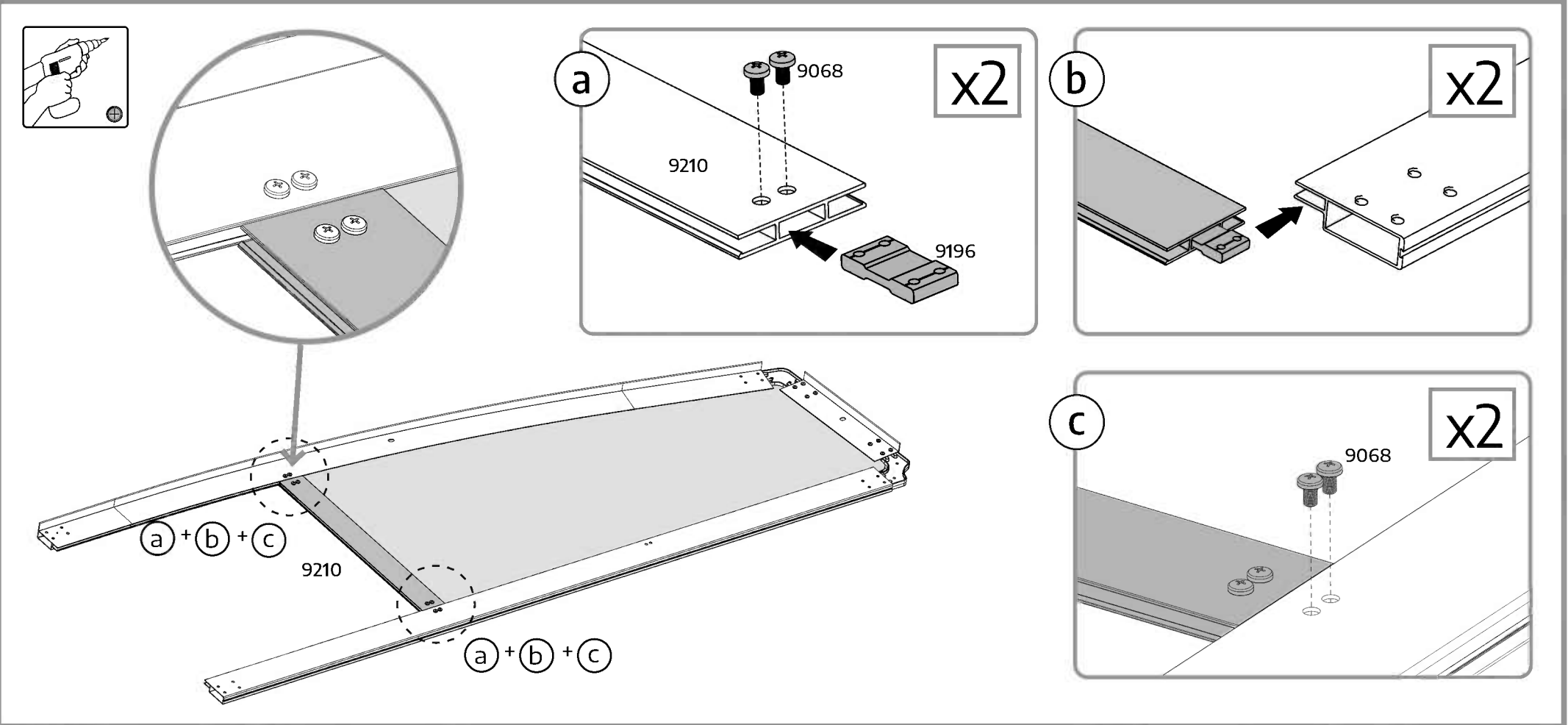
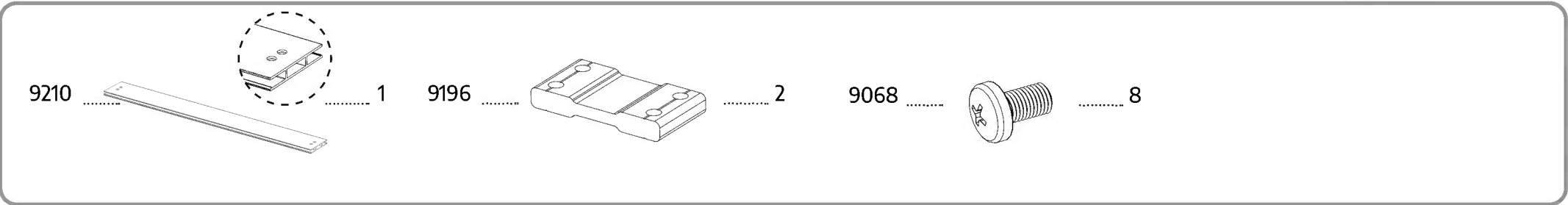
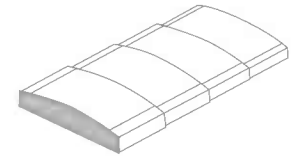

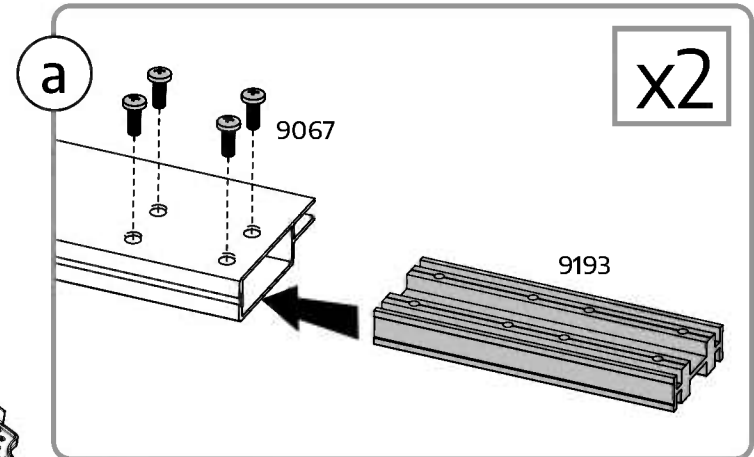
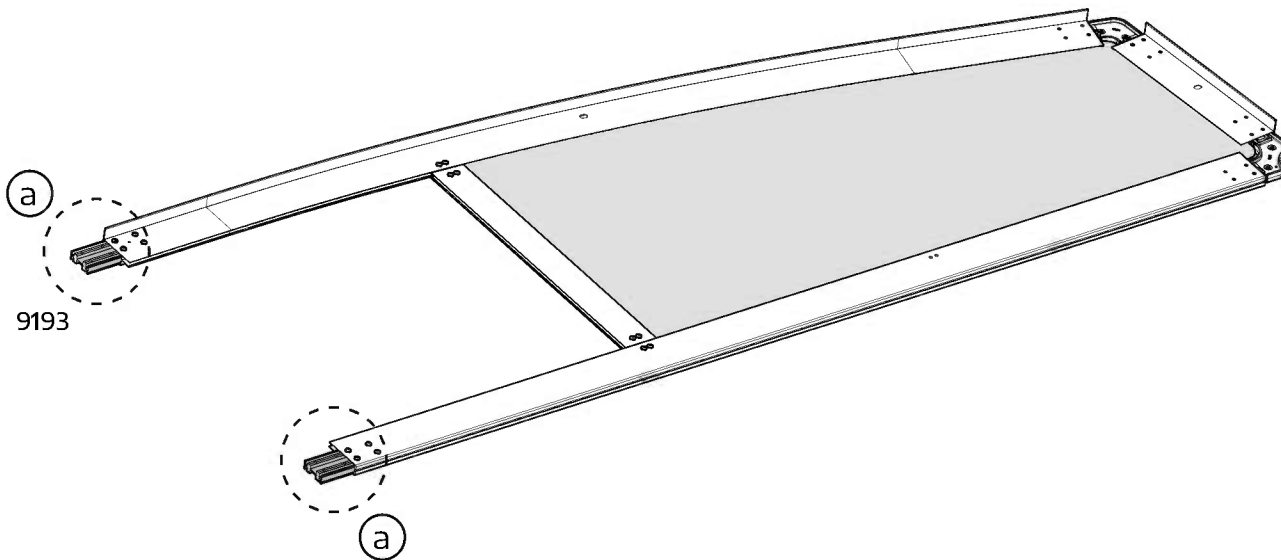
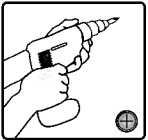
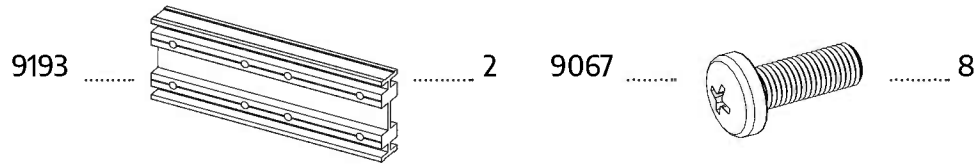
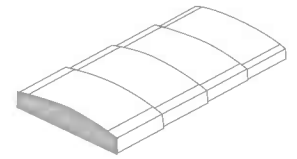

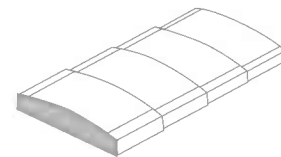

9182 1

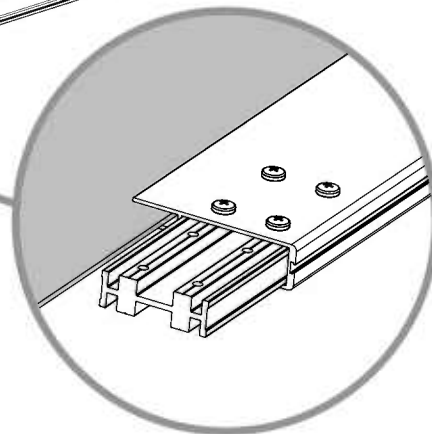
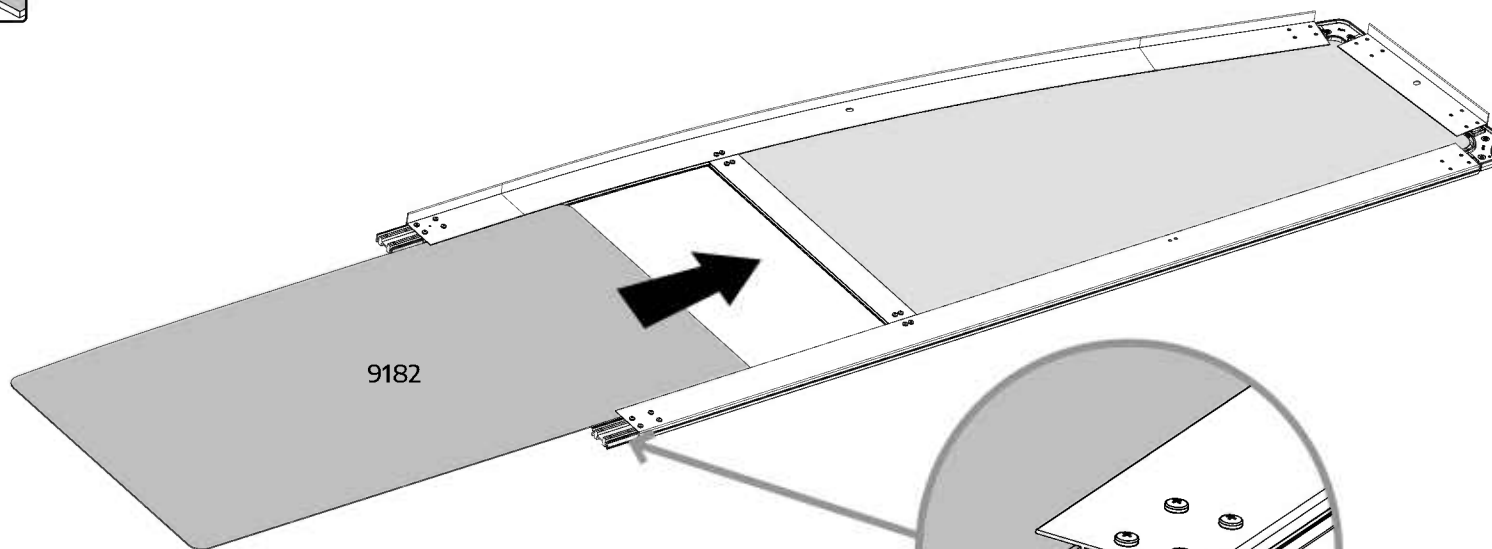
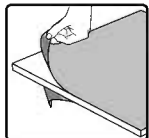
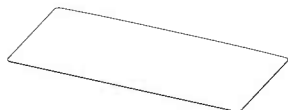

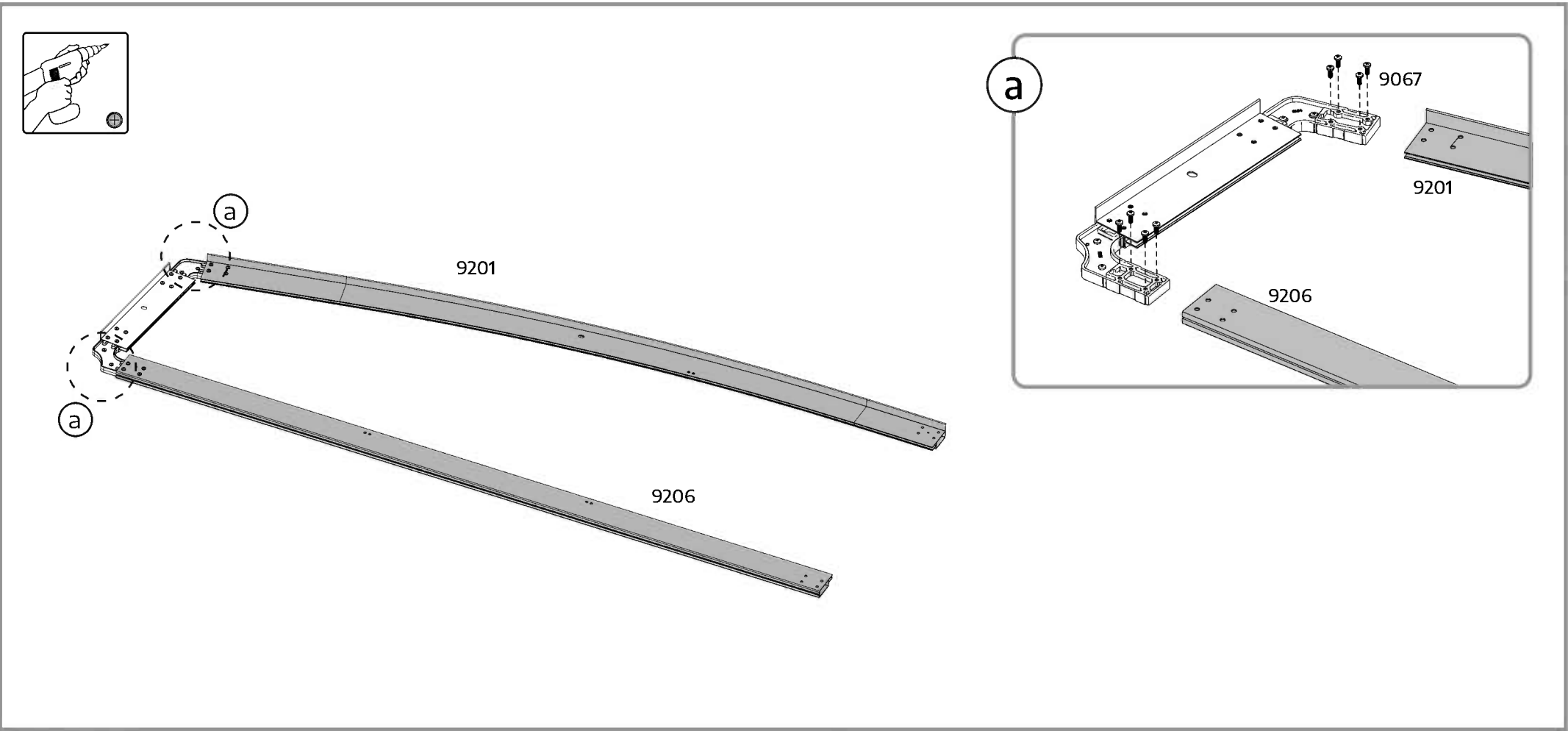
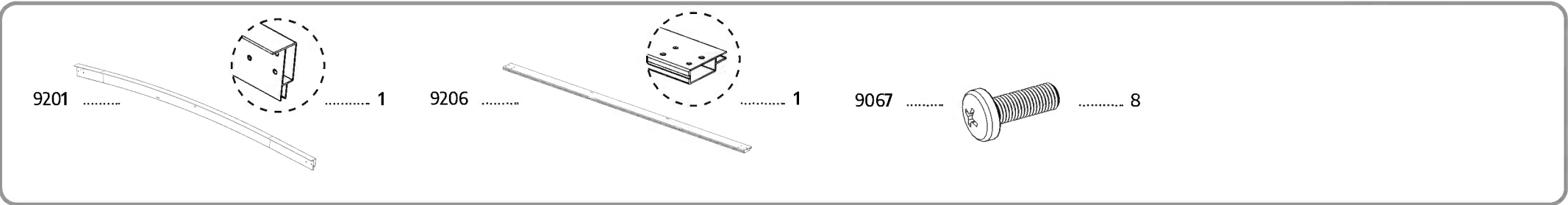
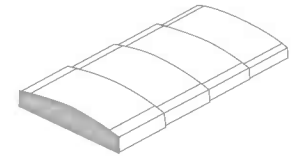

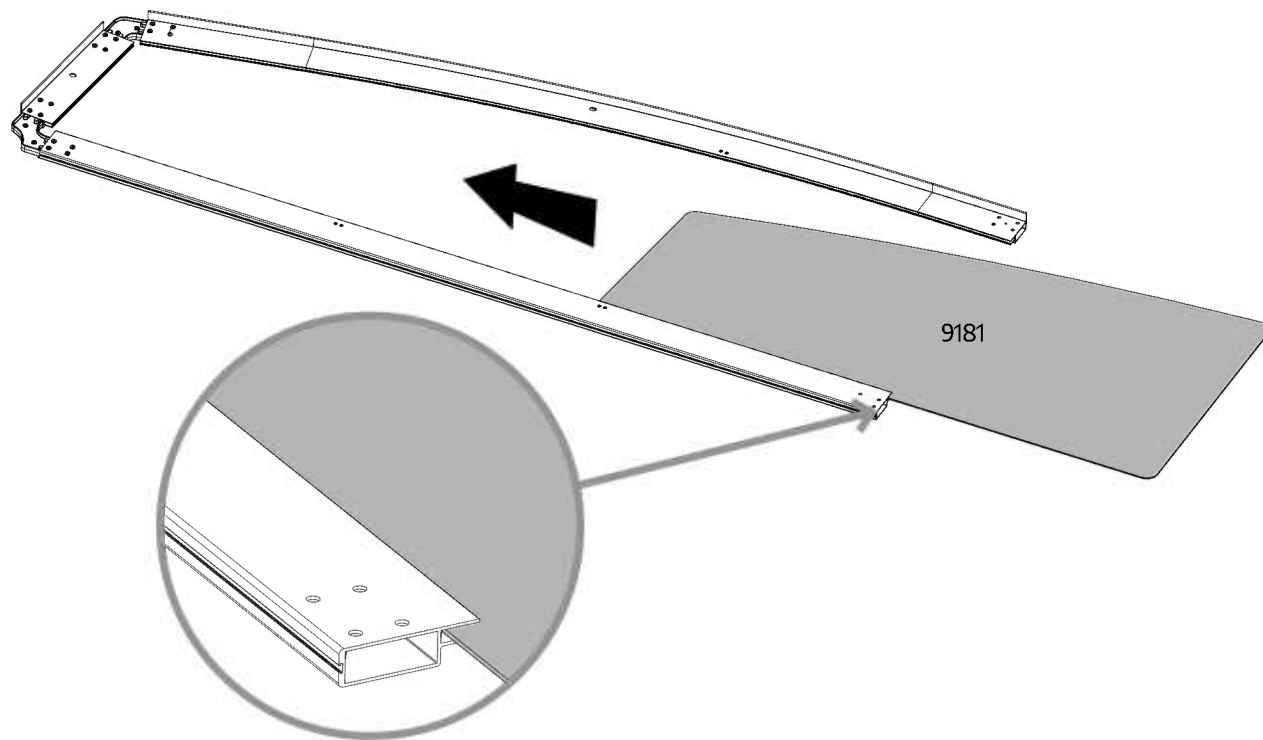
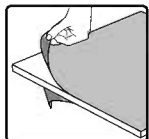
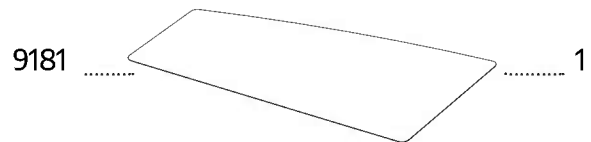
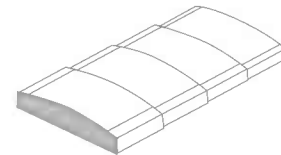

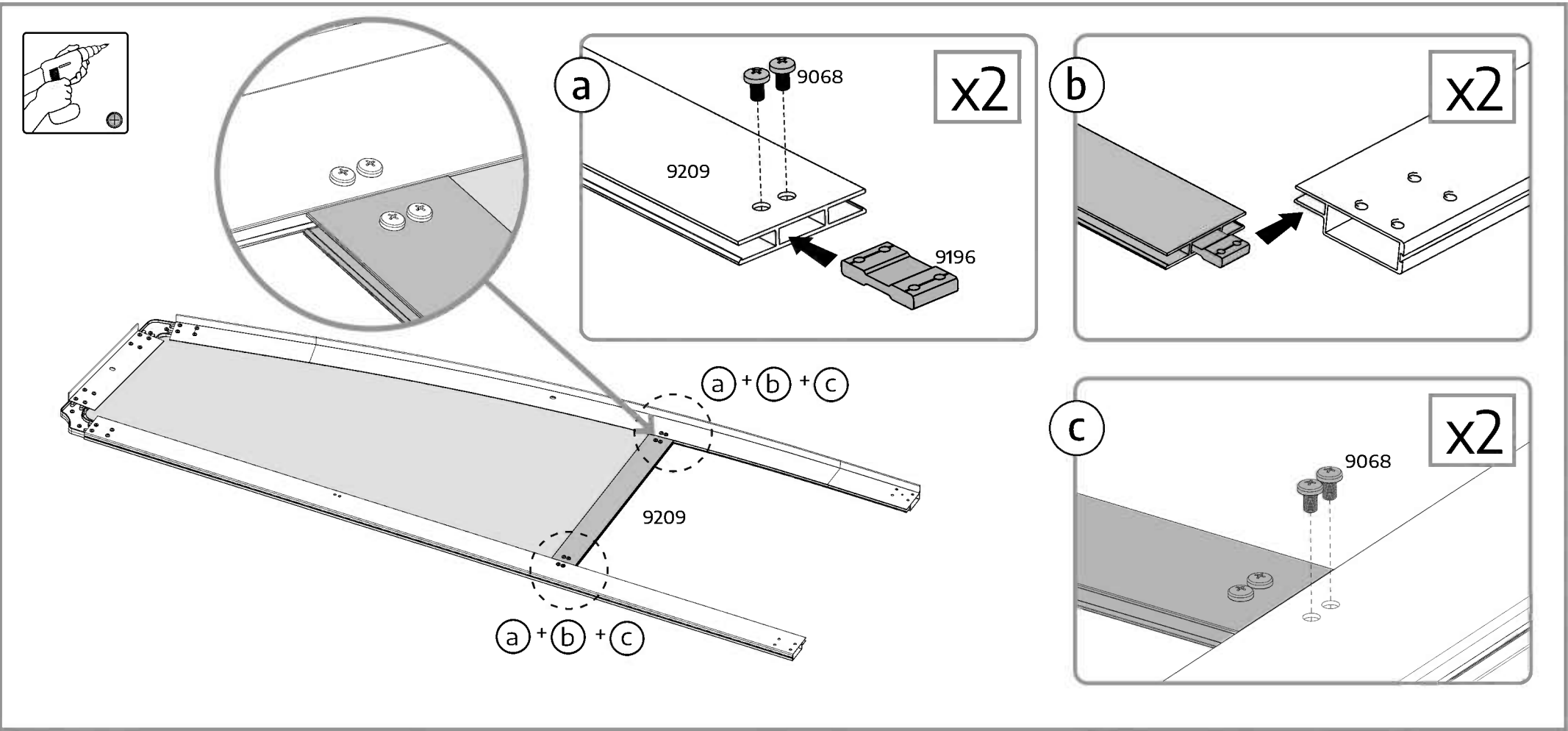
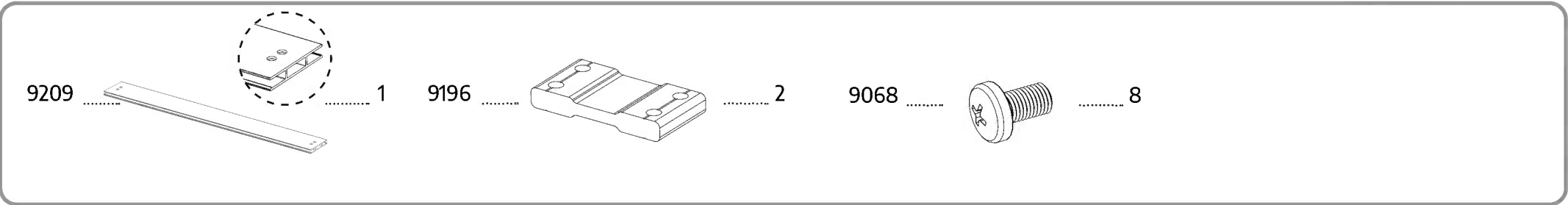
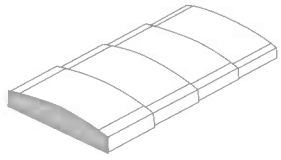

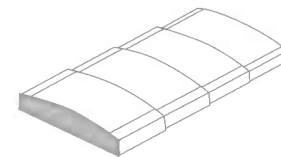

9067 8

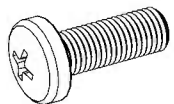

..... 8

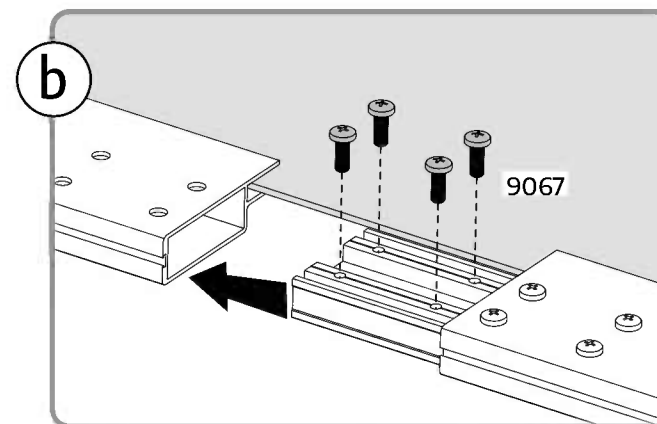
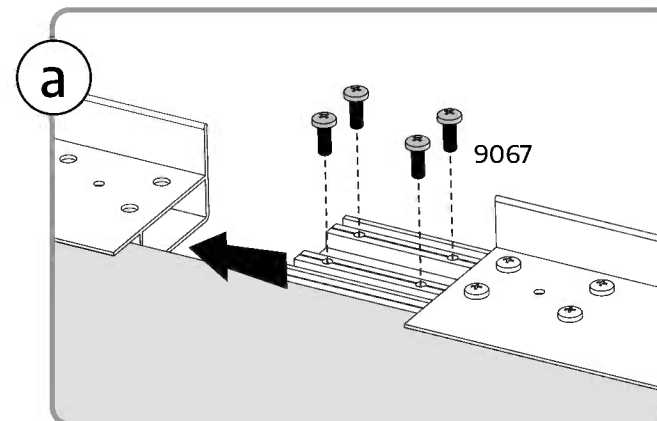
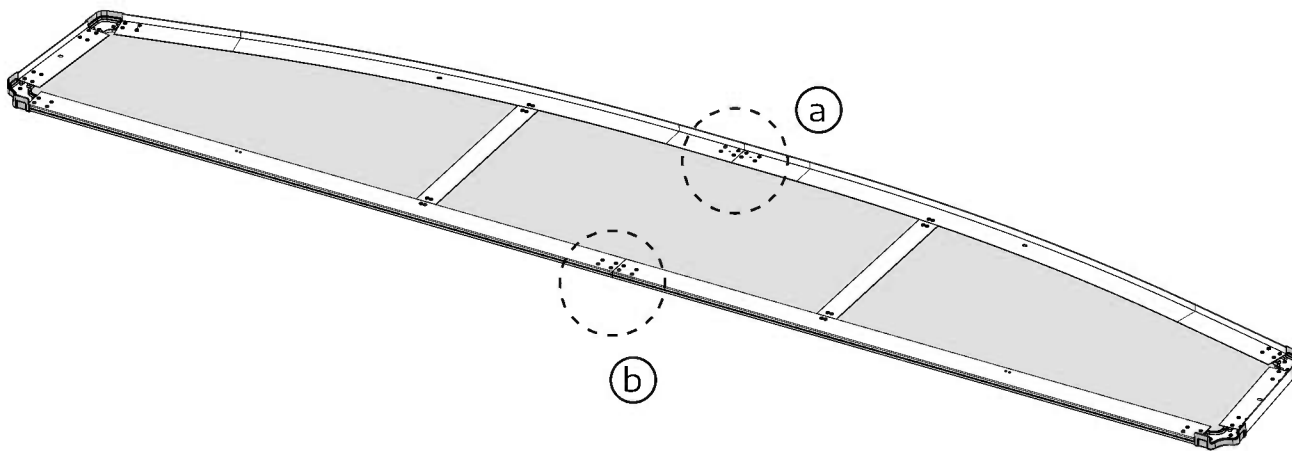
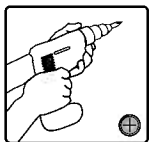

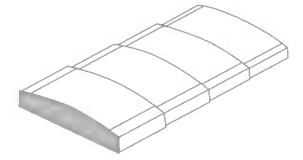

- 9197 2
- 9198 2
- 9068 8

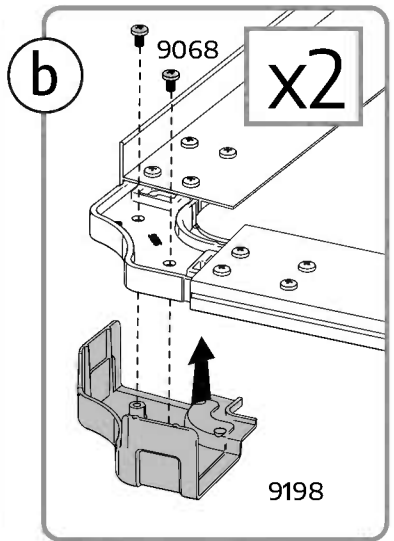
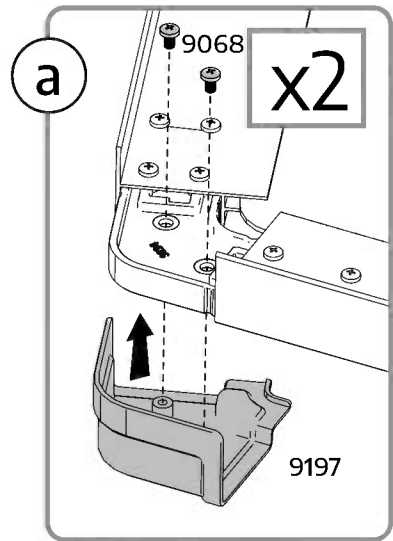
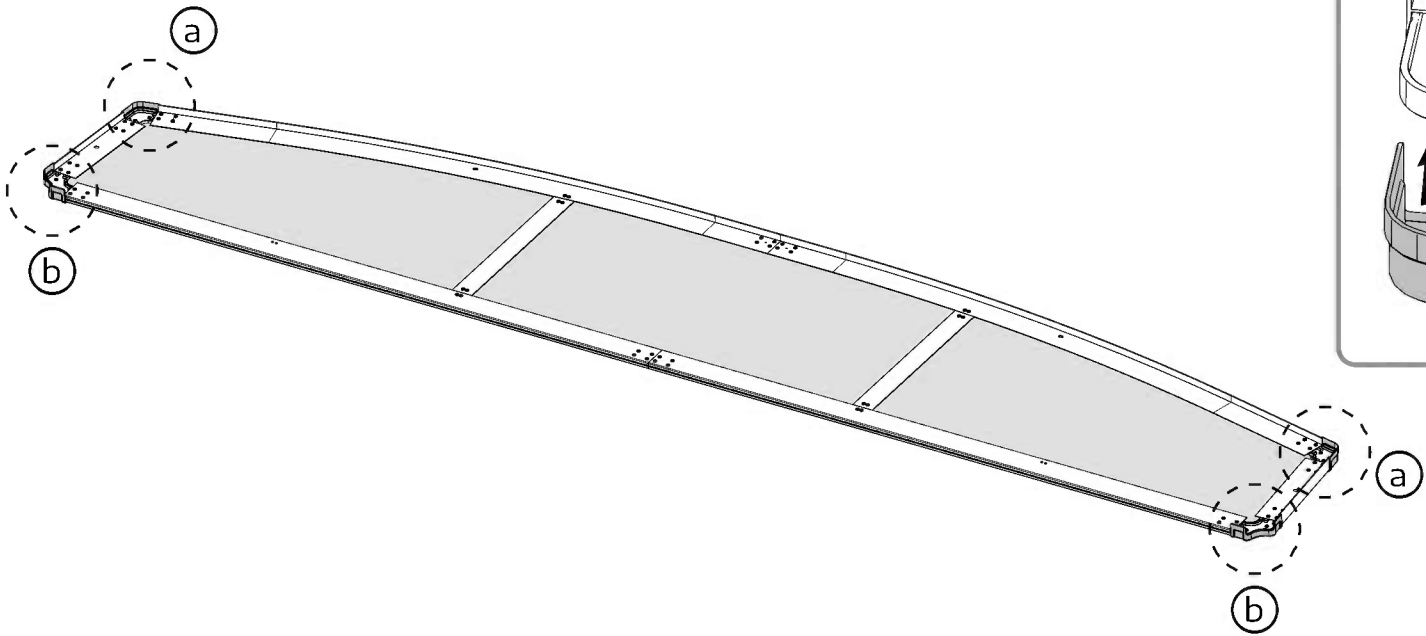
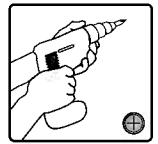

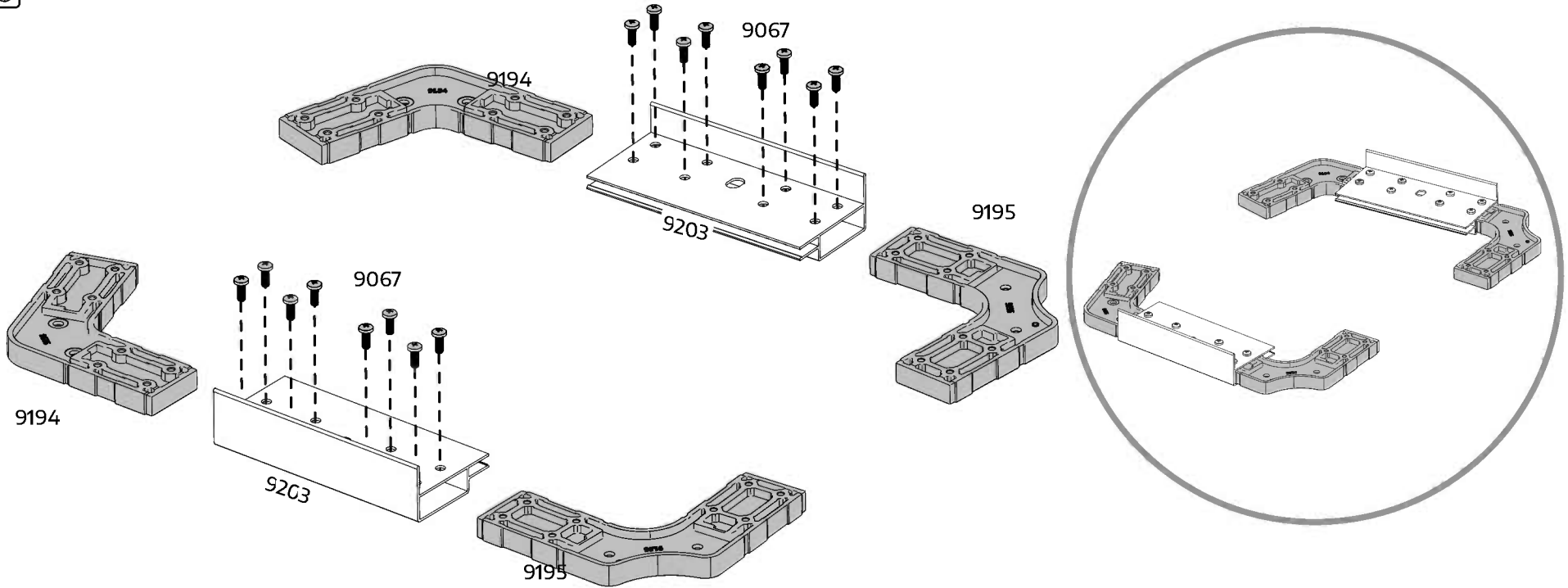
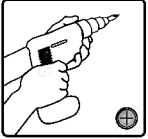
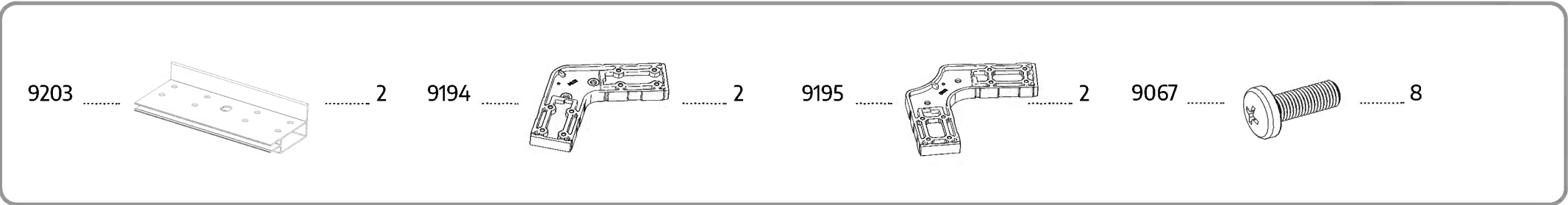
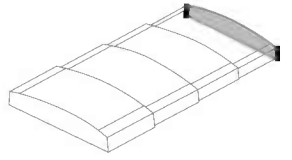

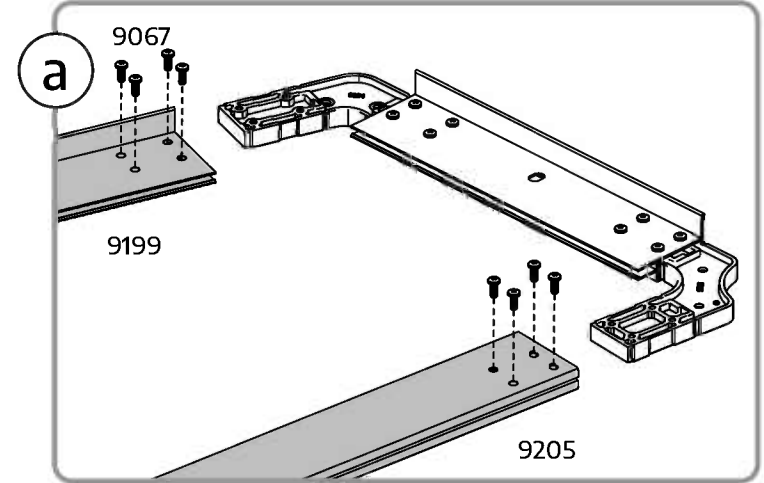
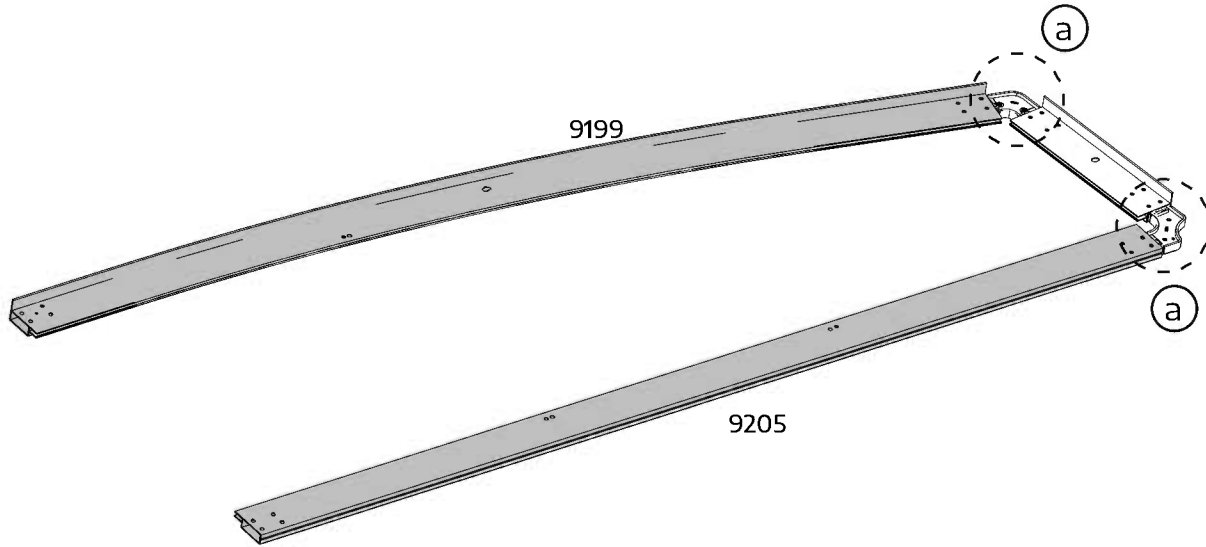
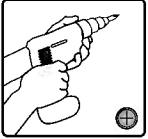
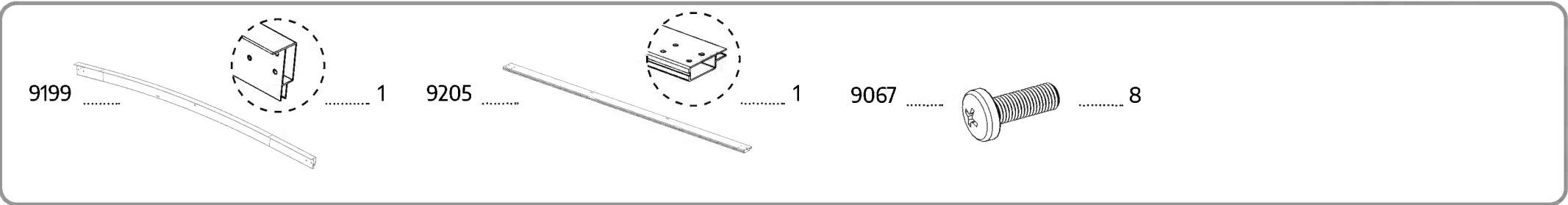
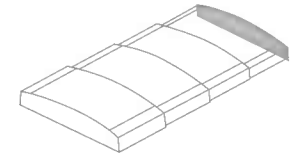

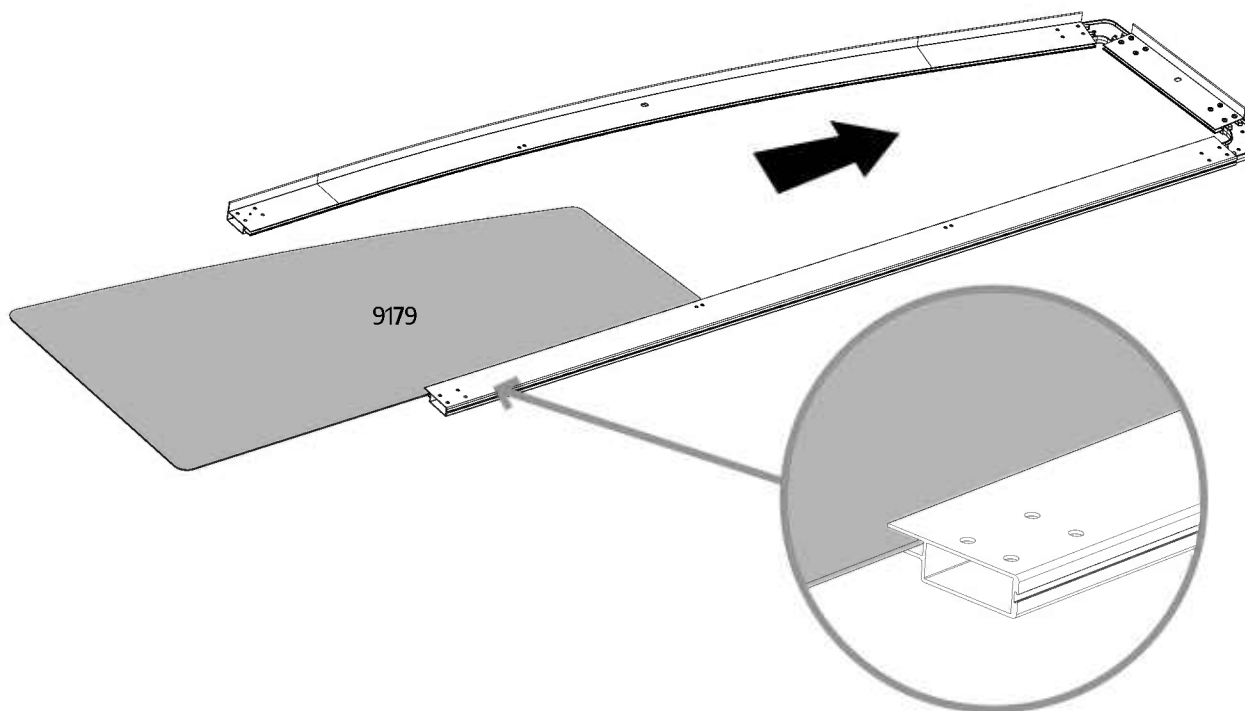
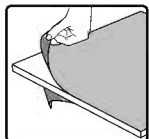
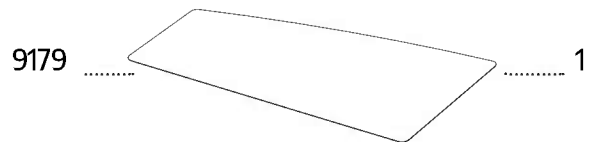
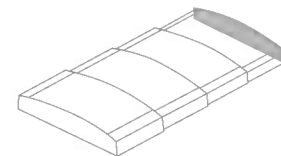

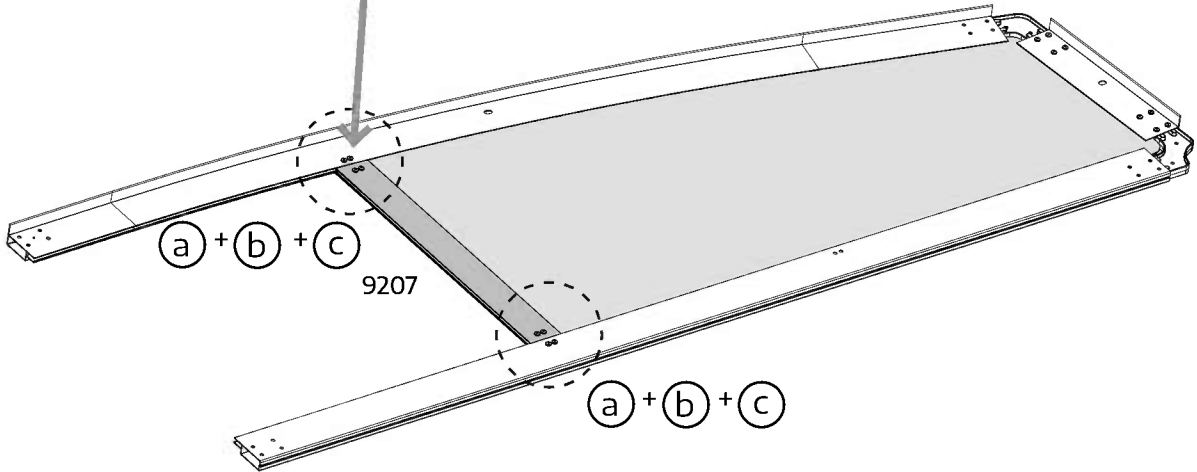
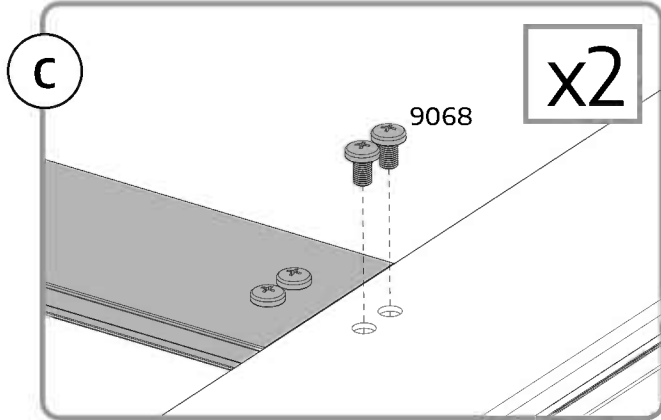
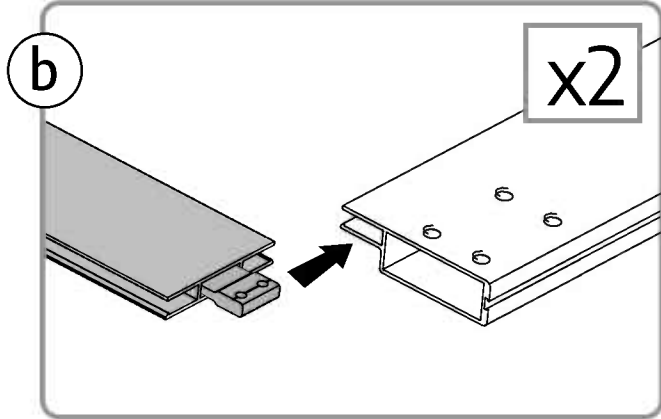
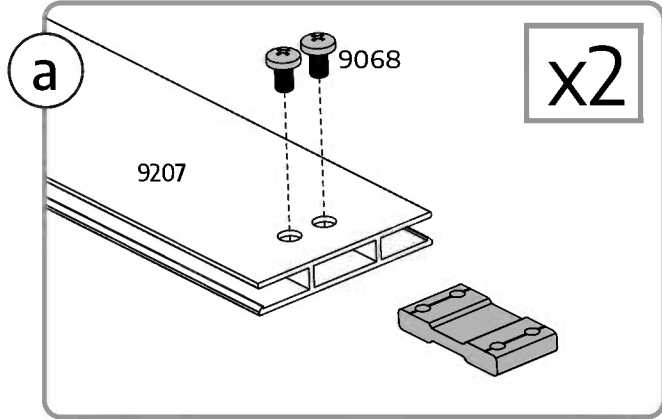
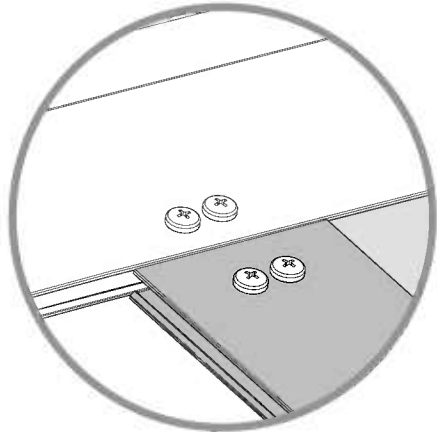
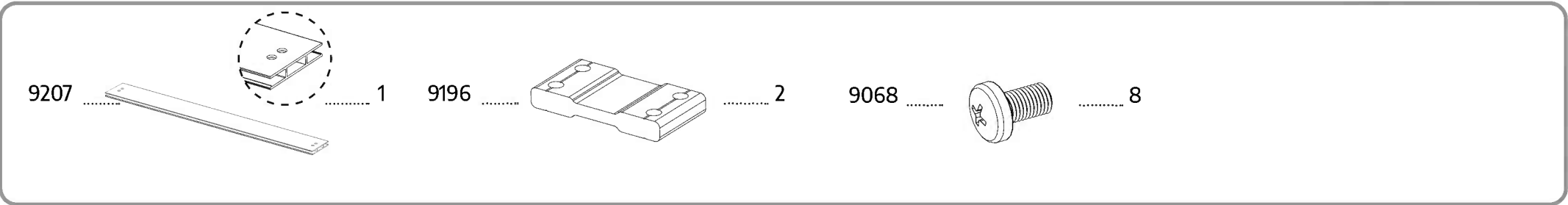
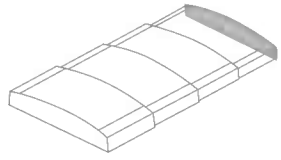

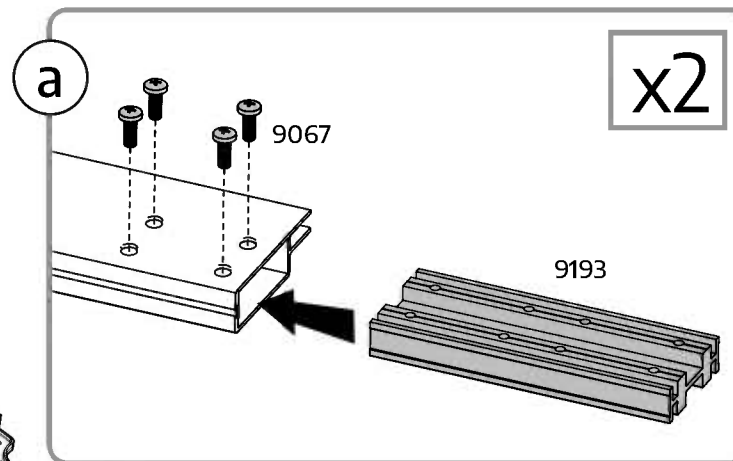
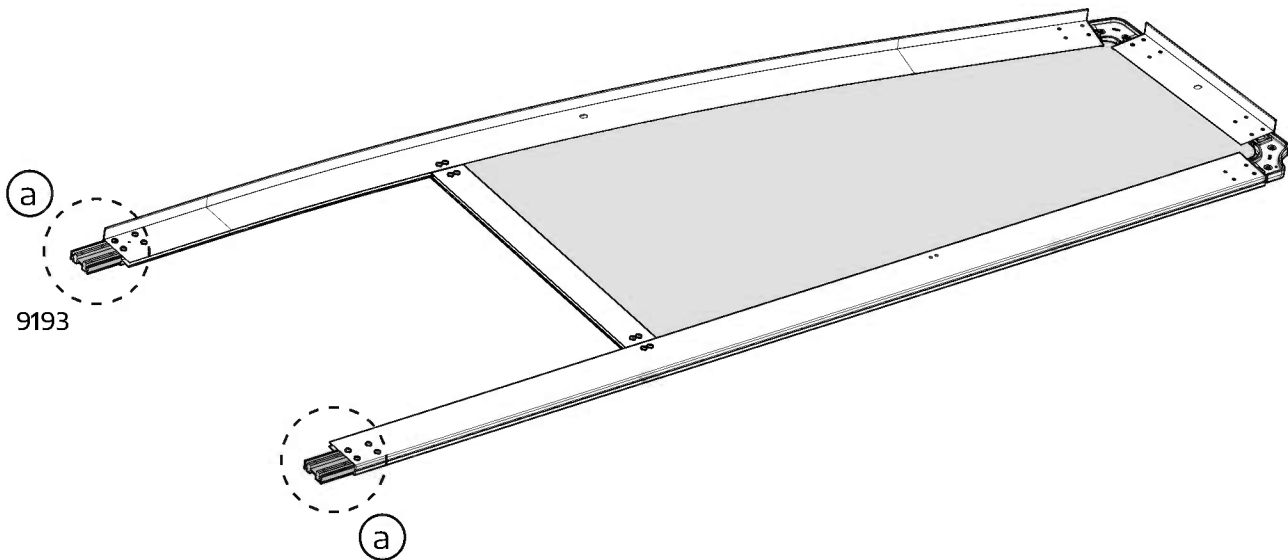
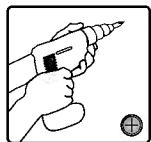
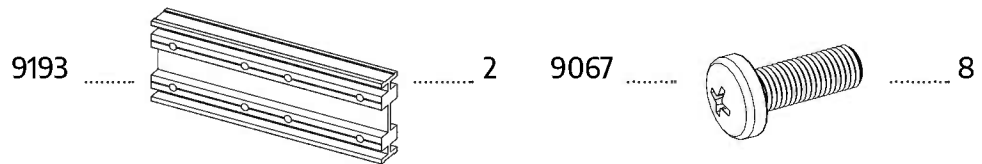
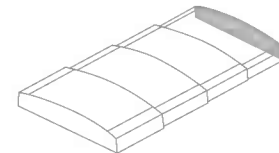

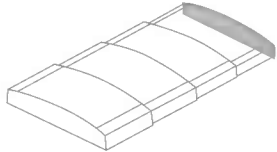

9180

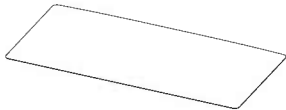

..... 1

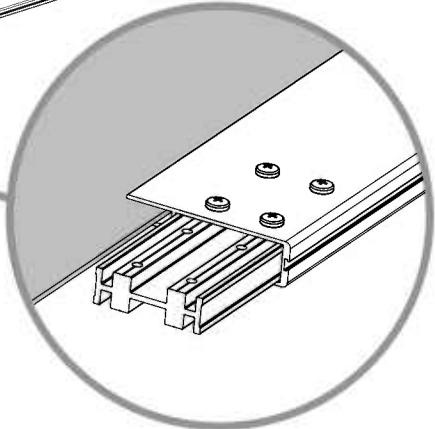
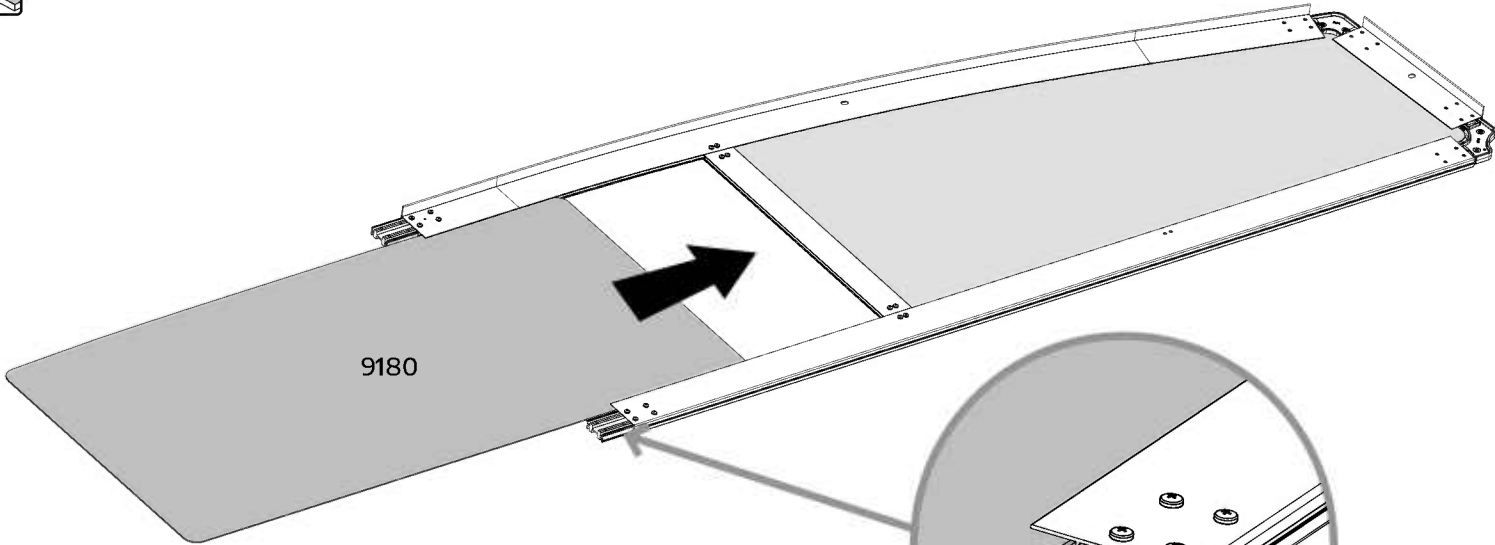
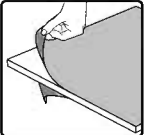

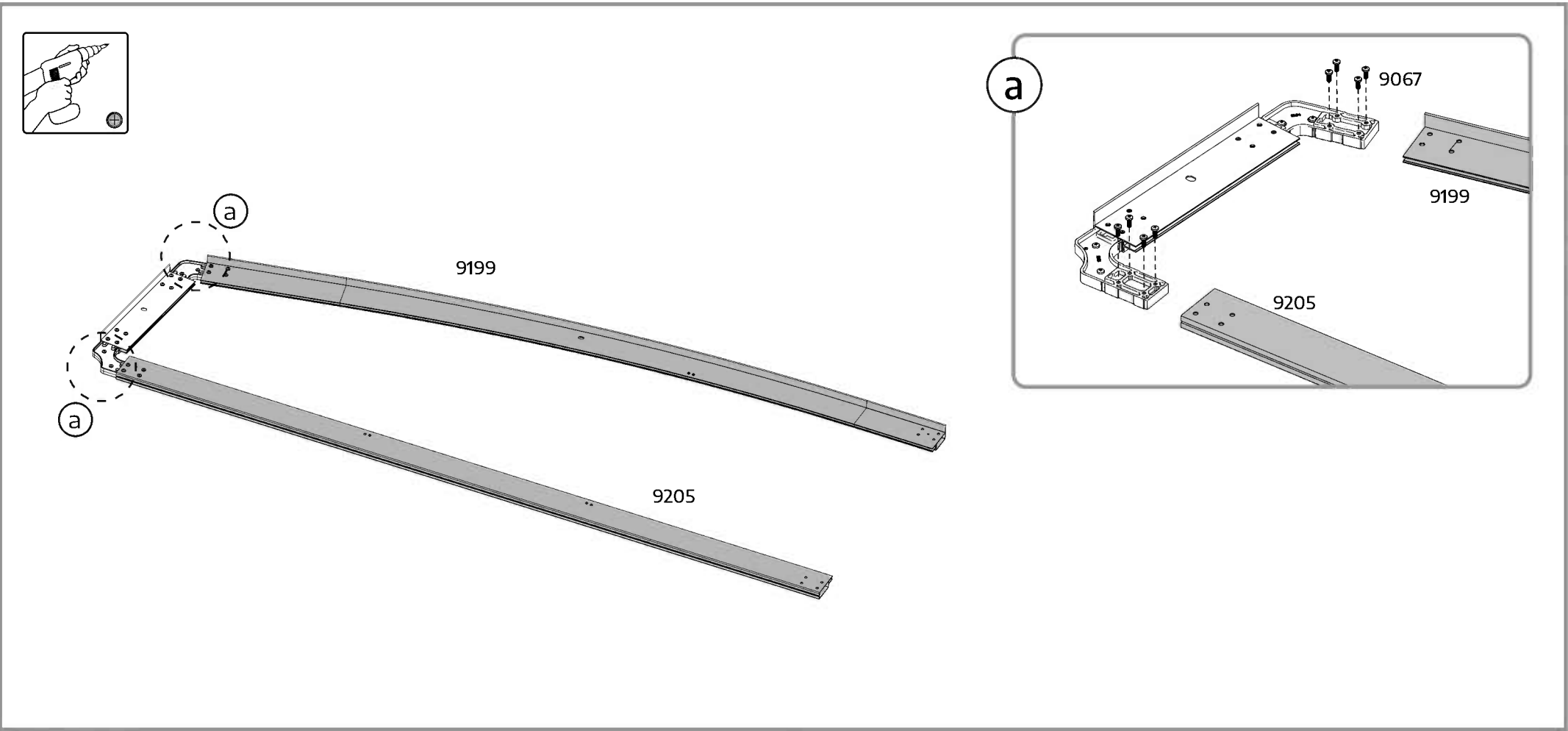
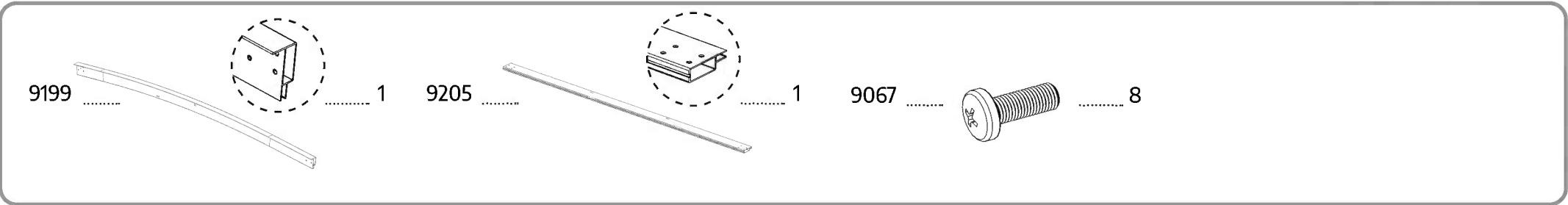
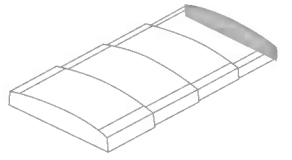

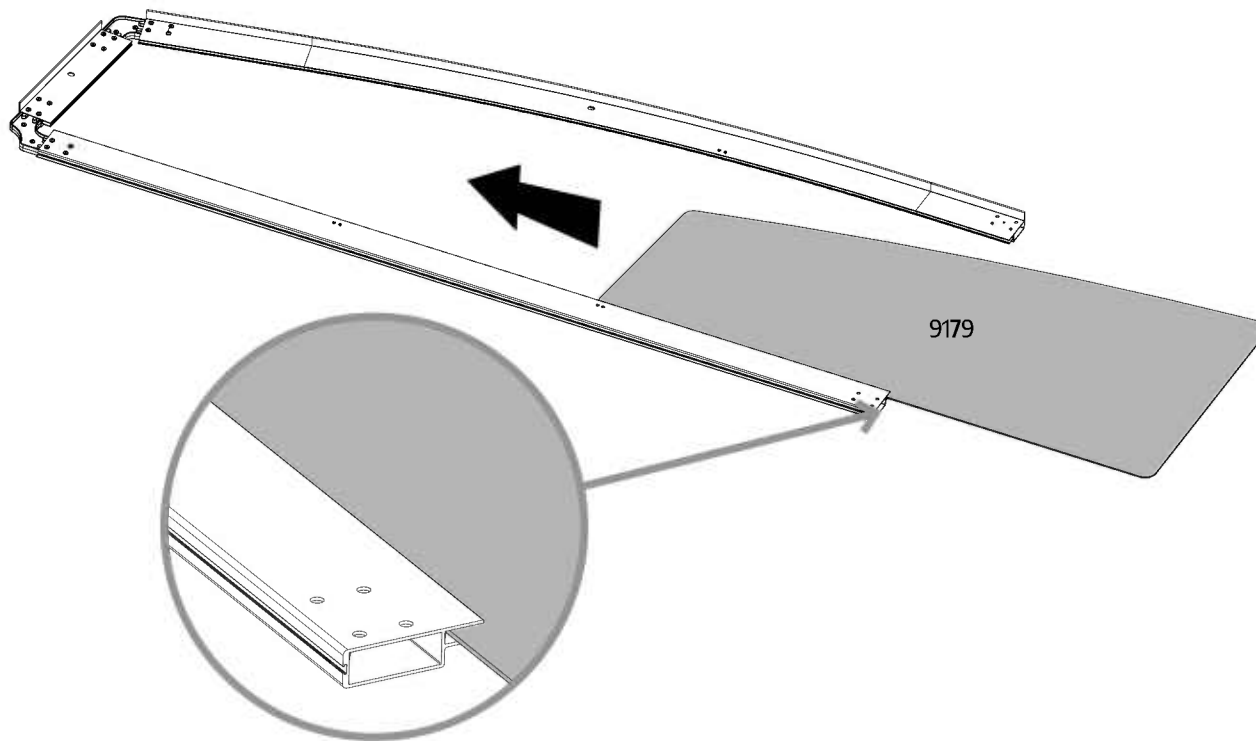
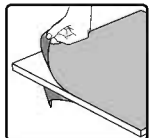
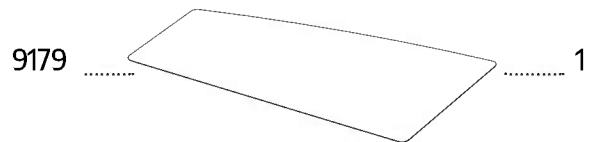
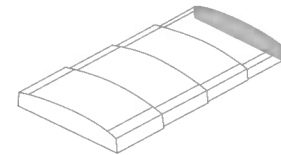

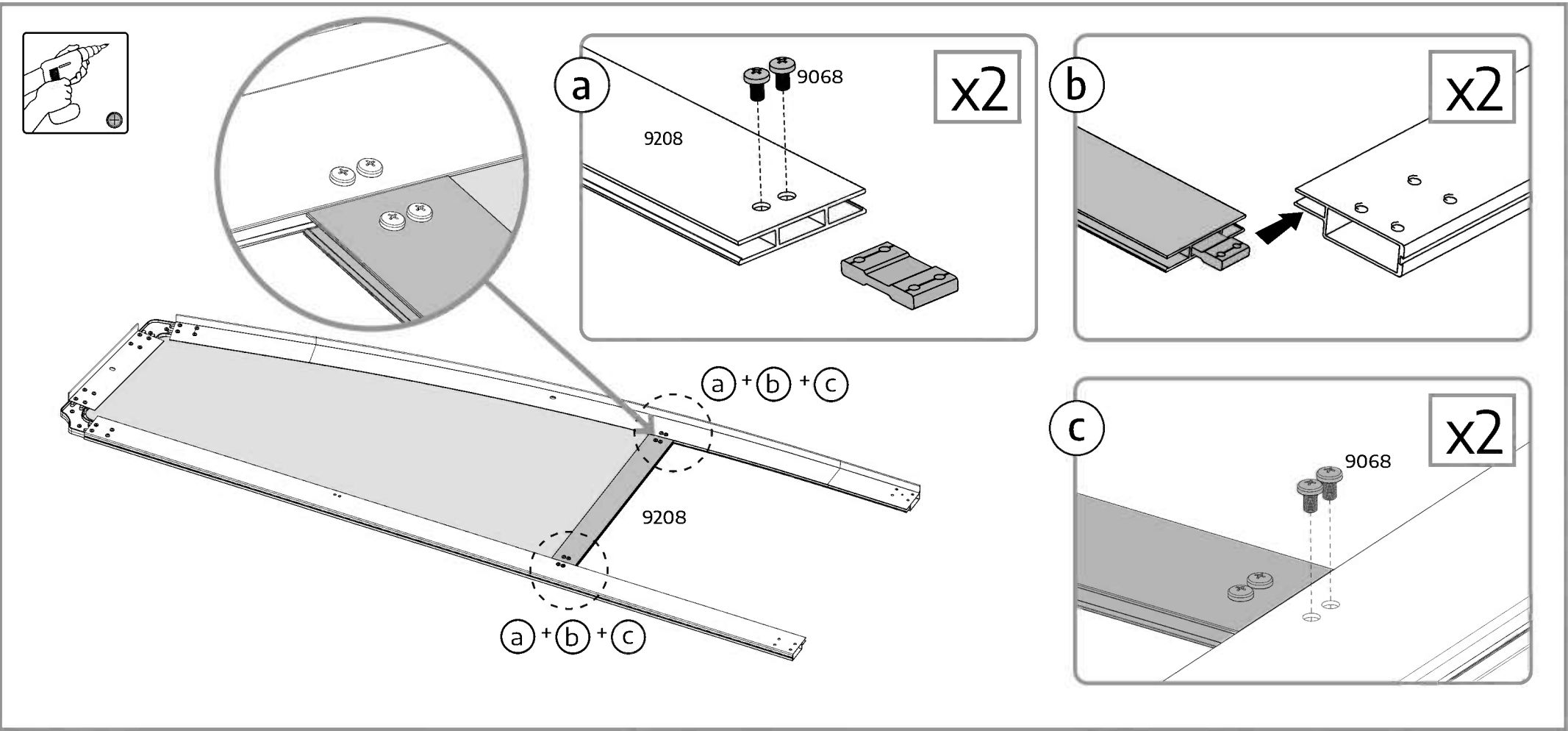
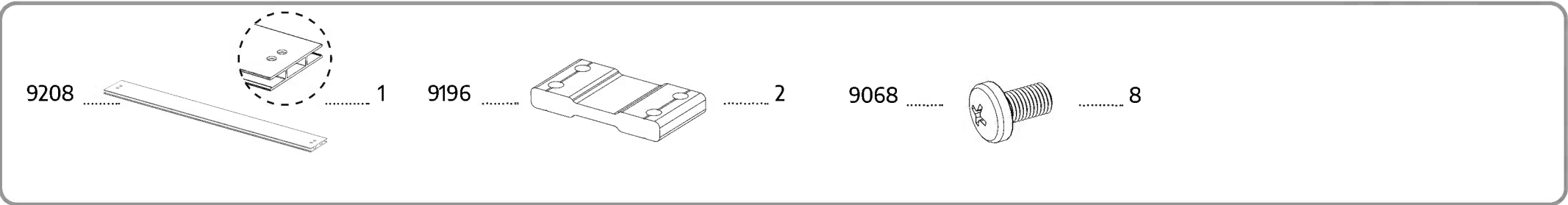
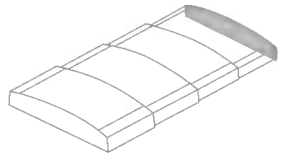

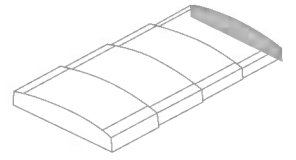

9067 8

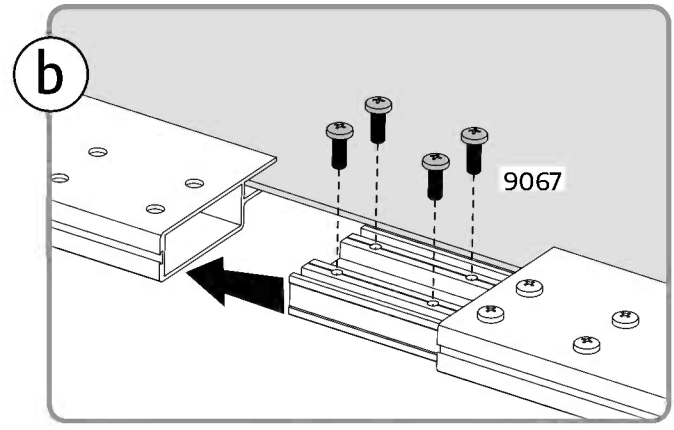
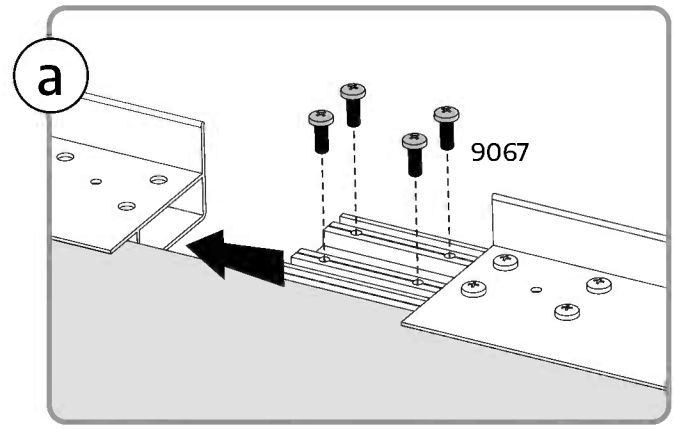
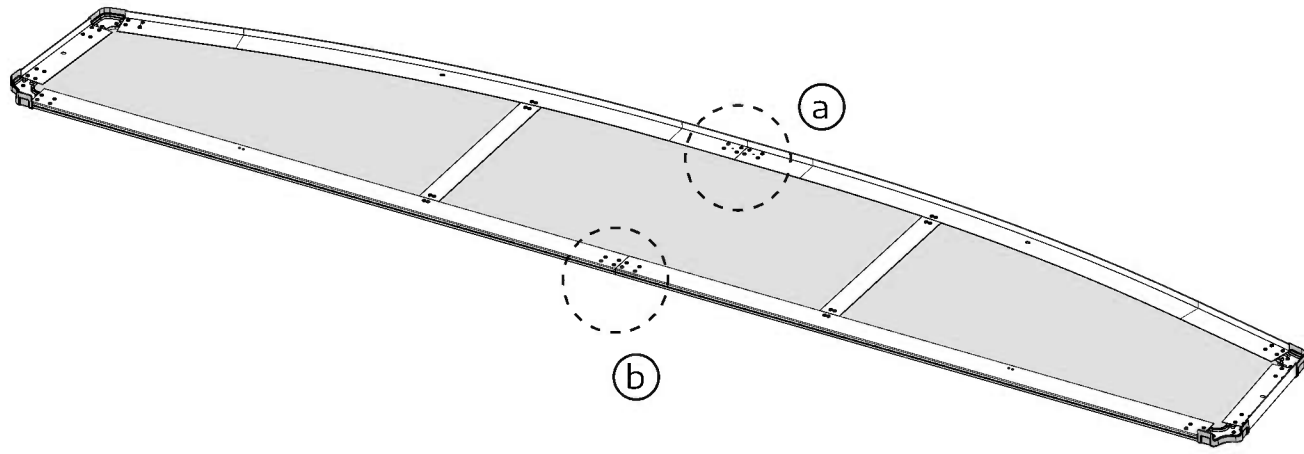
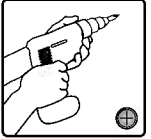
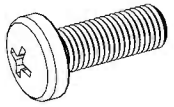

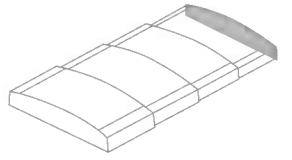

9197 2 9198 2 9068 8

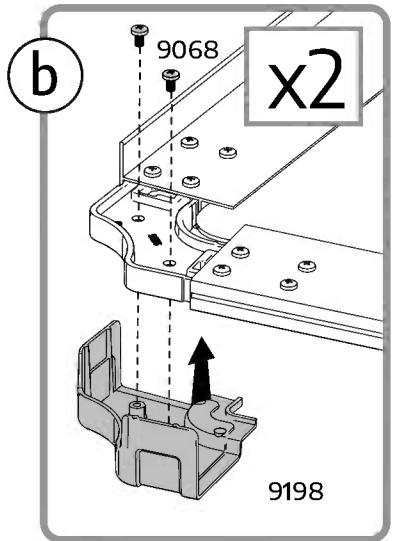
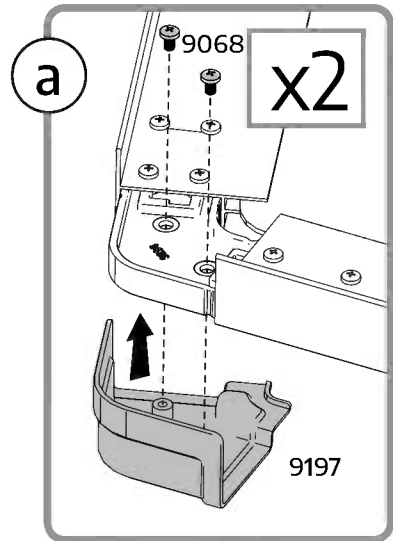
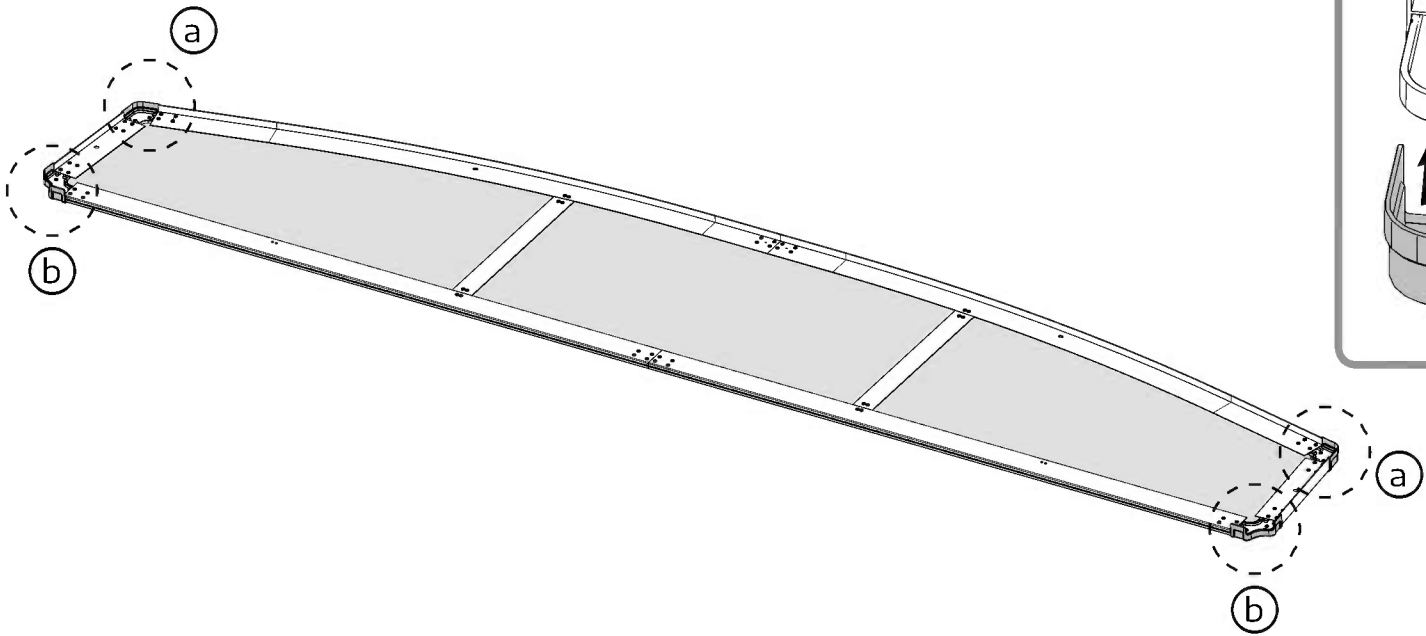
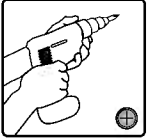

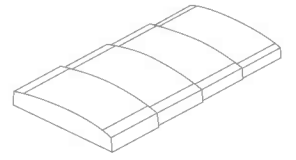

For Steps 95, 97:

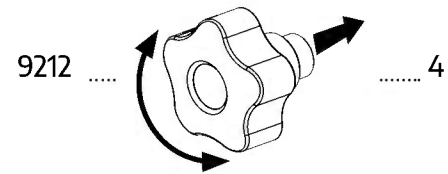
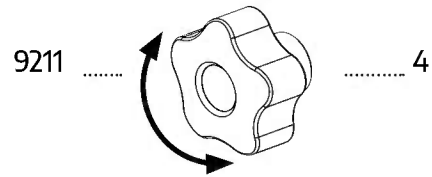

For Page 99:

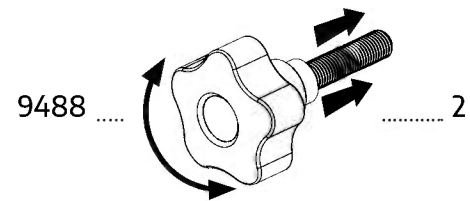
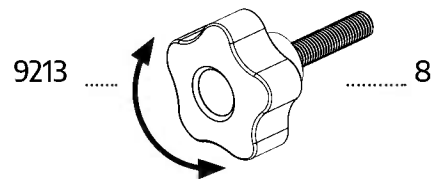

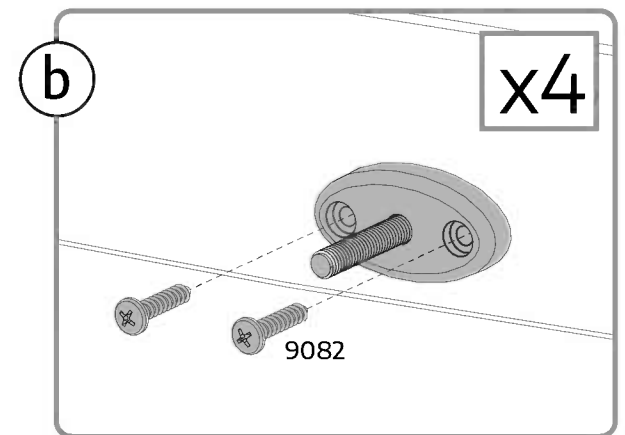
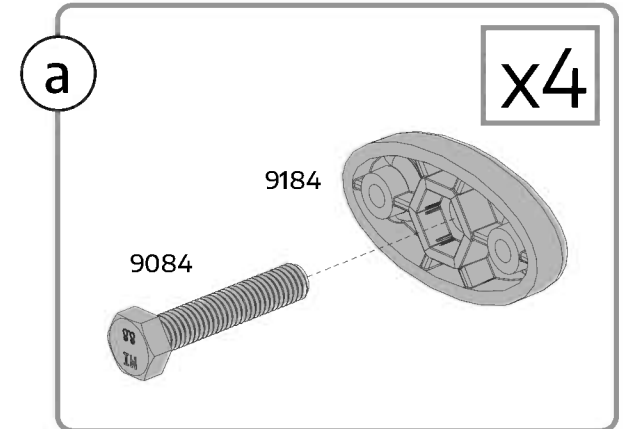
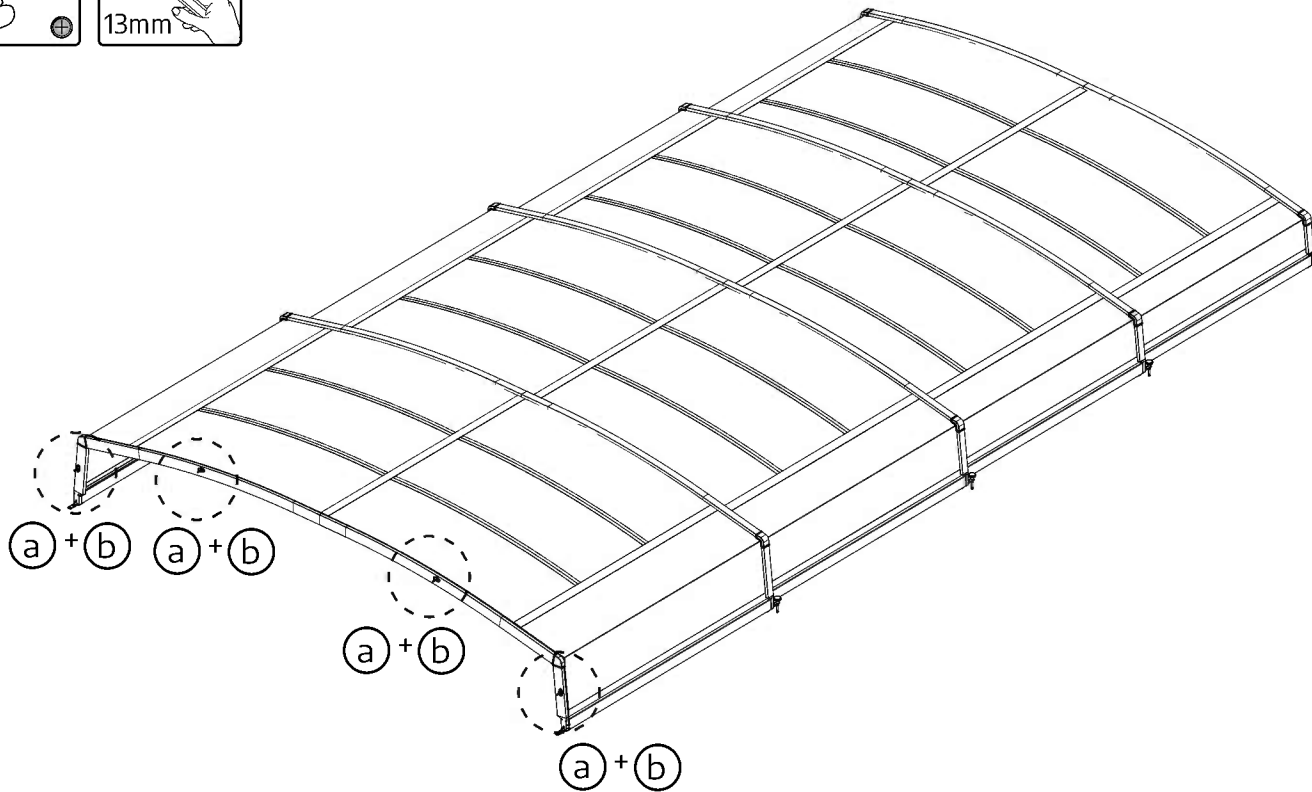
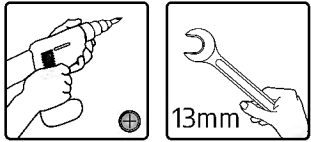
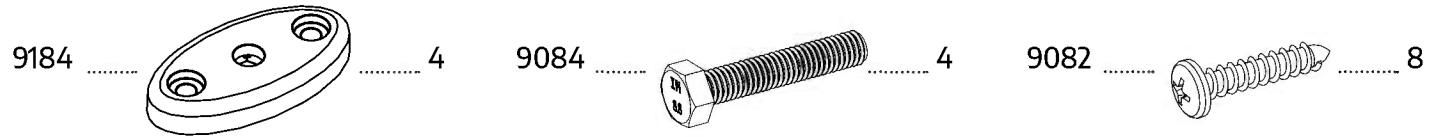
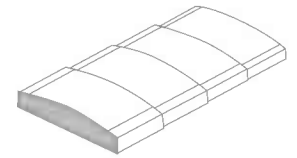



In Diagram **b** part **#9212** should be locked by pushing and screwing.

Clean and dry the profile with a cloth before attaching the “warning label” as shown in Figure C. The label marks the locking area for child safety.

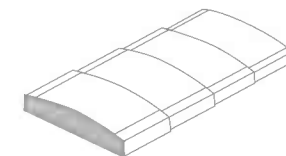

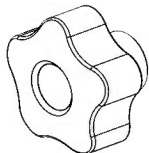
9211  2

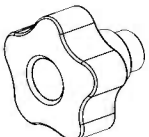
9212  2

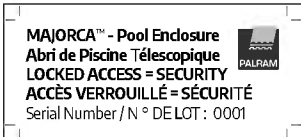
9710  2

MAJORCA™ - Pool Enclosure
 Abri de Piscine Télescopique
 LOCKED ACCESS = SECURITY
 ACCÈS VERROUILLÉ = SÉCURITÉ
 Serial Number / N° DE LOT : 0001

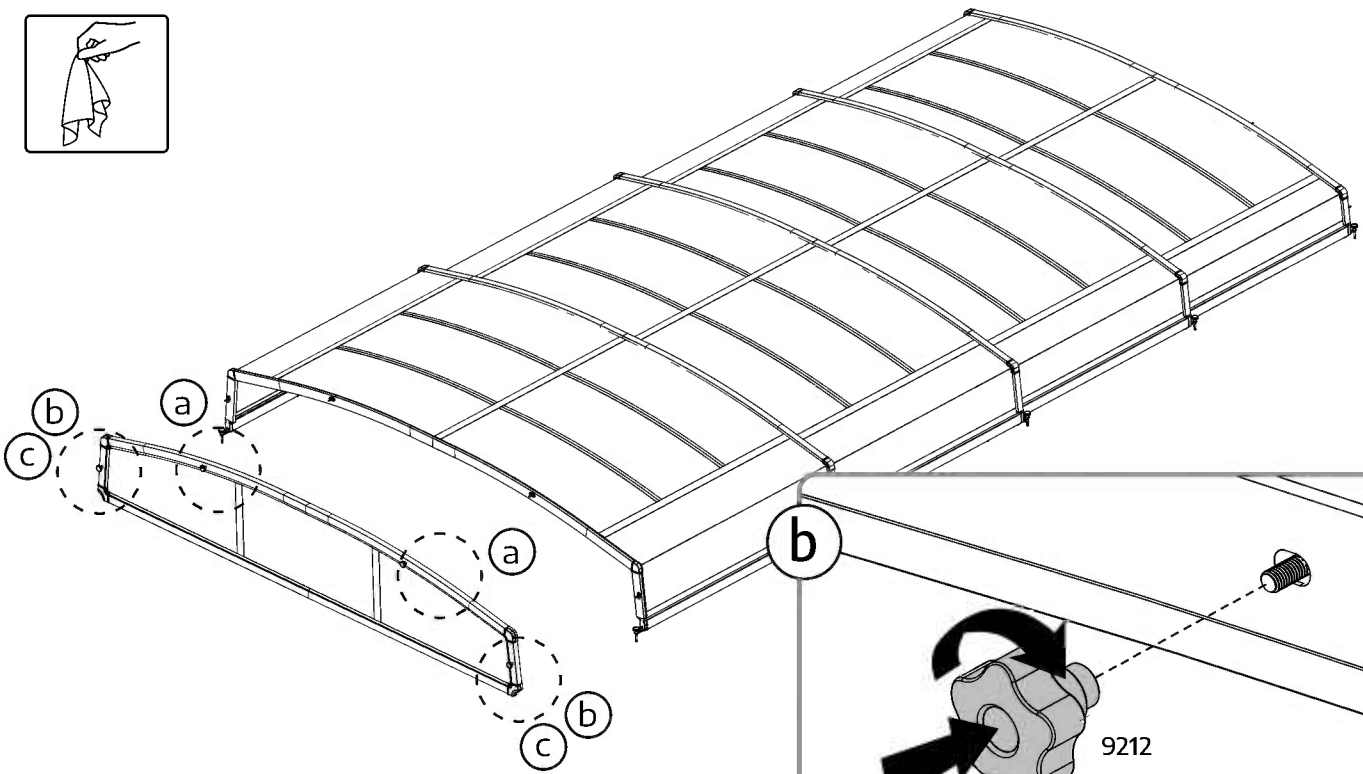

a



9211

x2

b

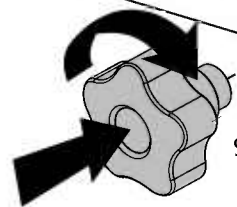

9212

x2

c

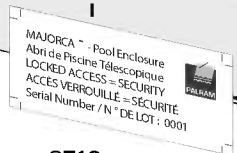

9710

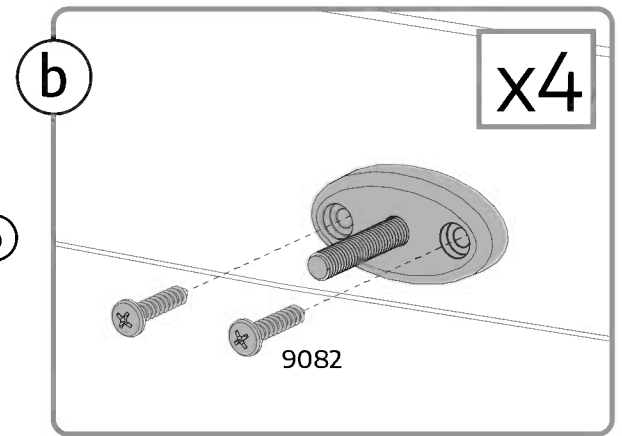
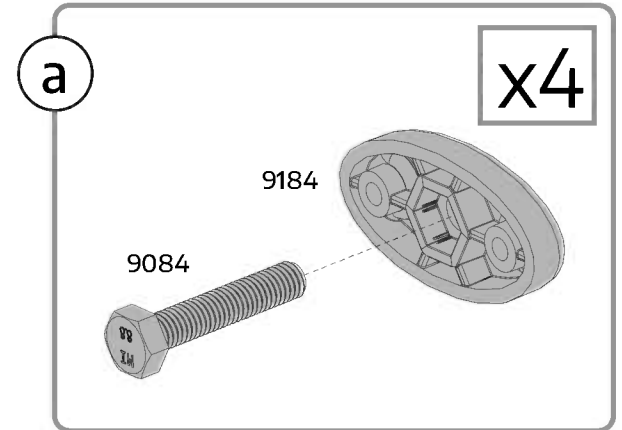
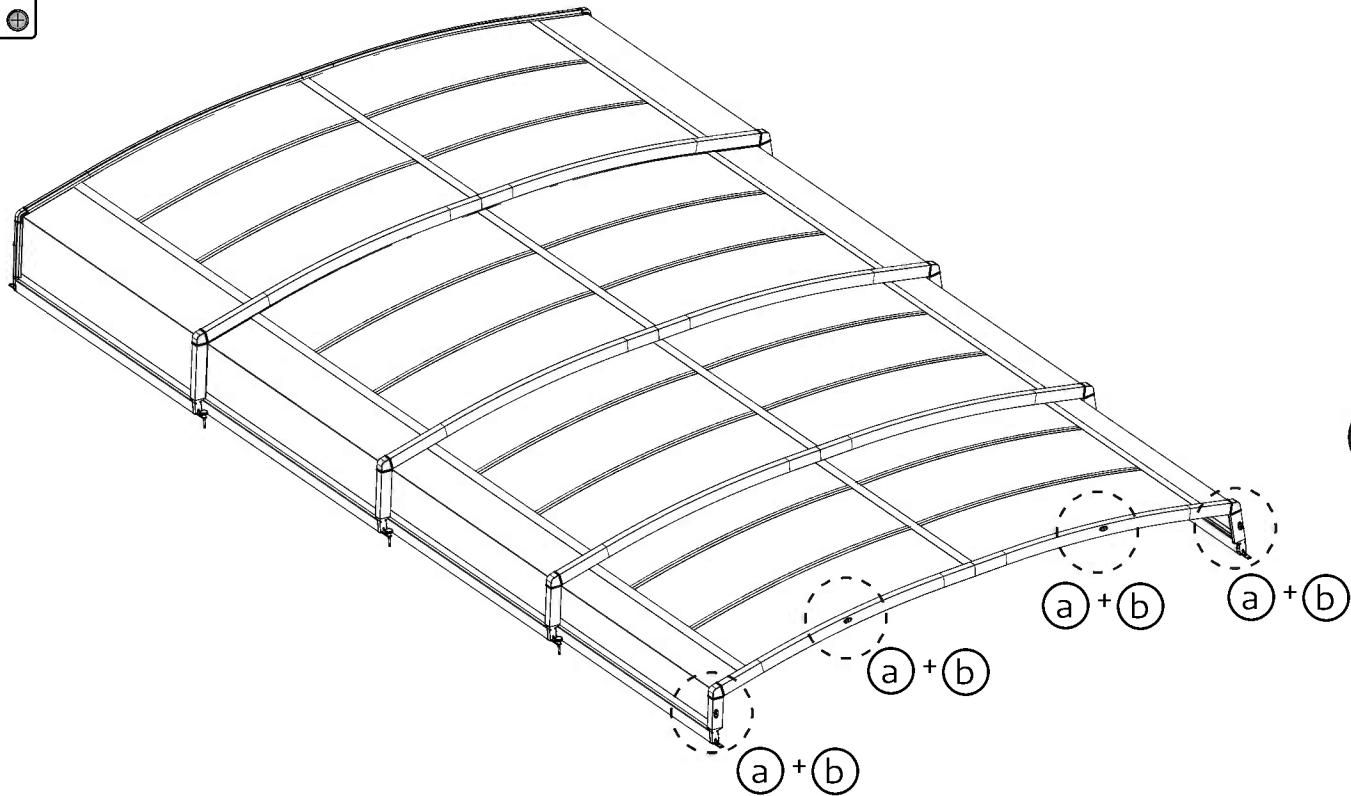
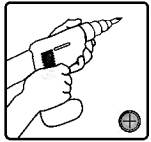
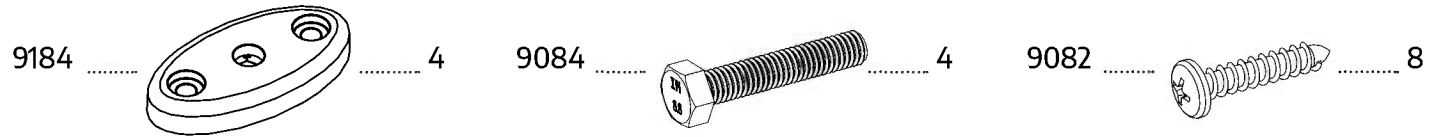
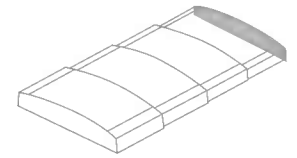



In Diagram **b** part **#9212** should be locked by pushing and screwing.

Clean and dry the profile with a cloth before attaching the “warning label” as shown in Figure C. The label marks the locking area for child safety.

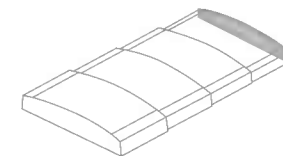

9211

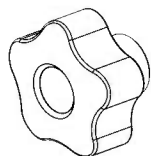

..... 2

9212



..... 2

9710

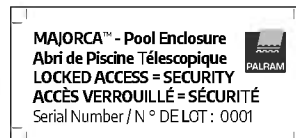

..... 2

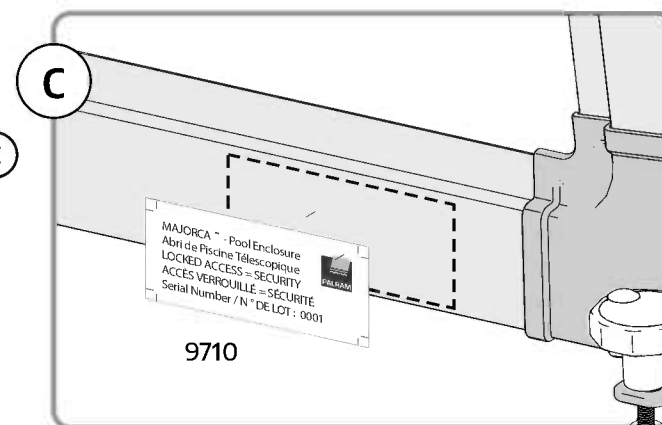
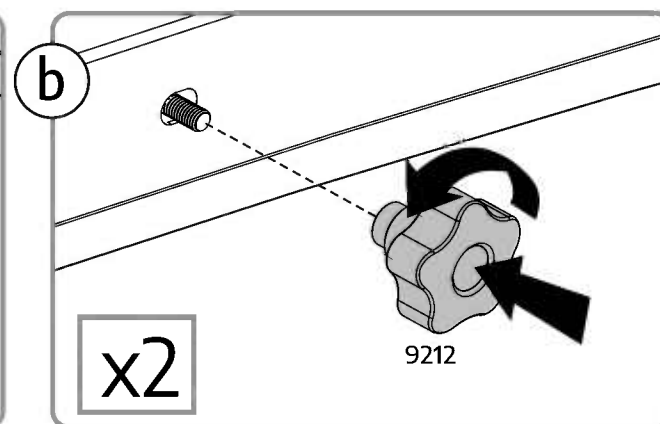
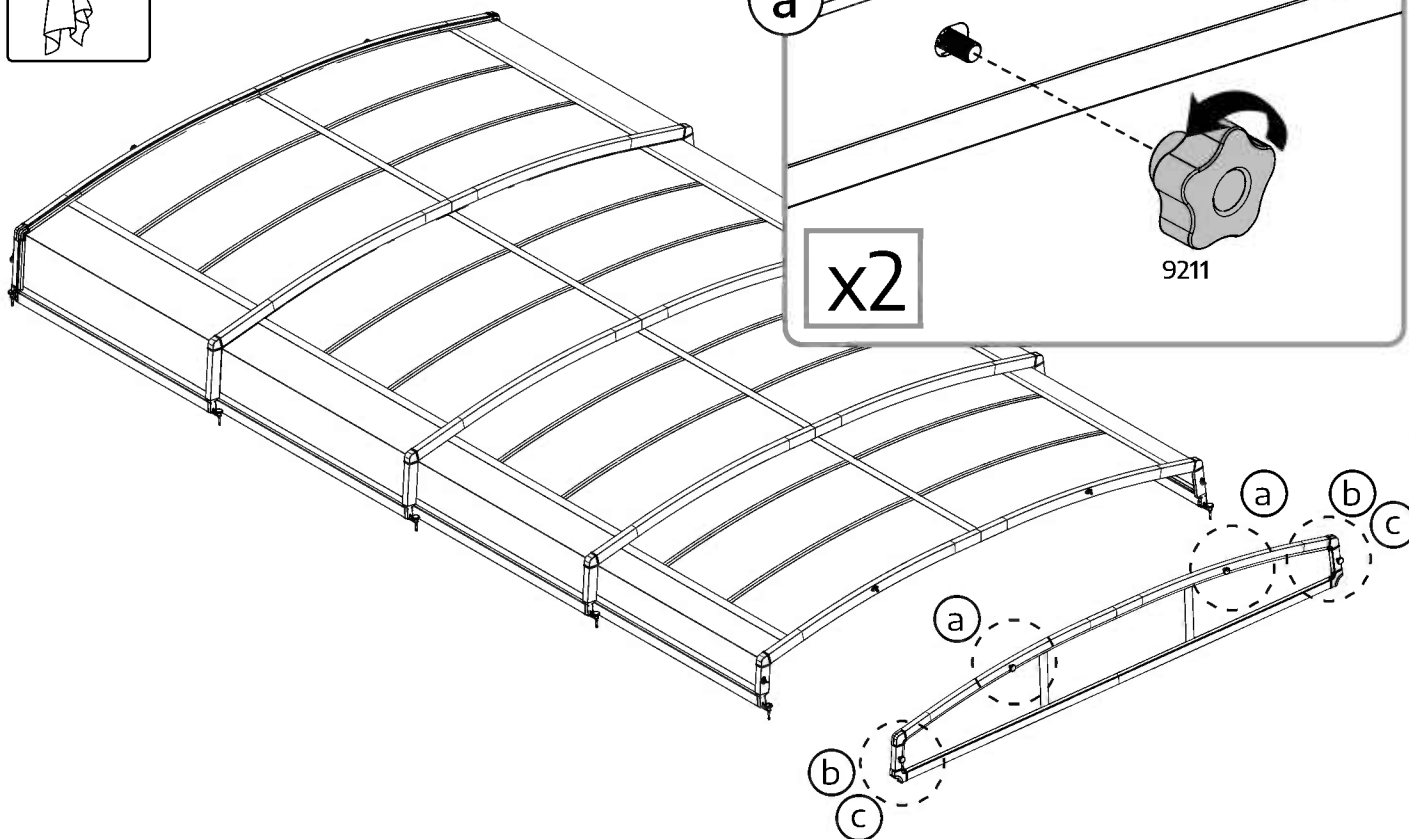

98



Do not anchor the product to the ground before completing steps 95 + 97.

The screws and masonry anchors supplied with the kit are suitable for concrete fixing only.
Please consult Customer Service regarding which fasteners are suitable for other surfaces types (not supplied).

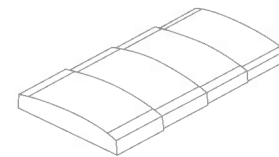

9489

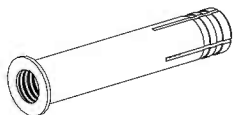

.....10

9490



.....10

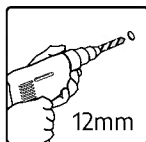

12mm

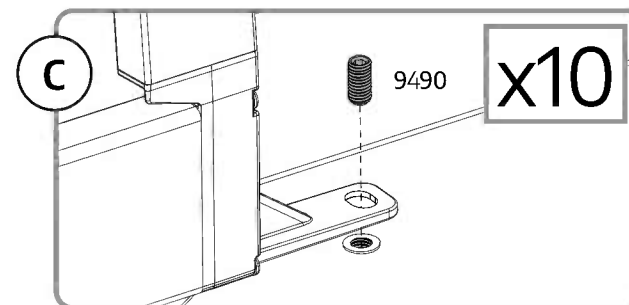
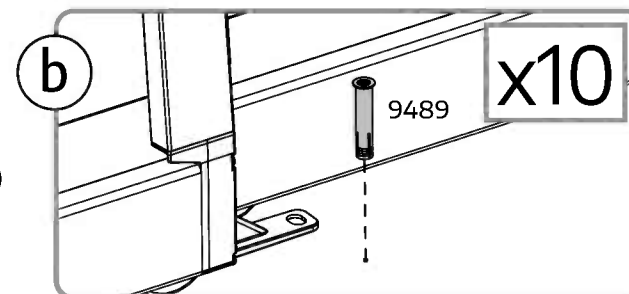
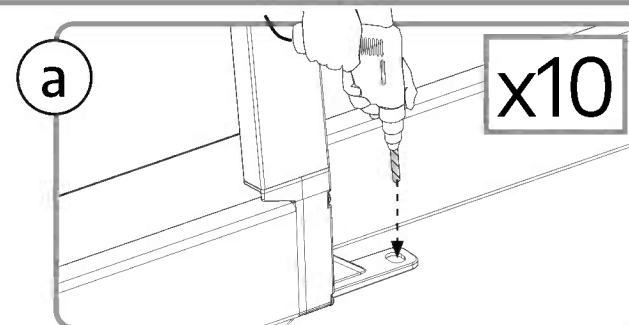
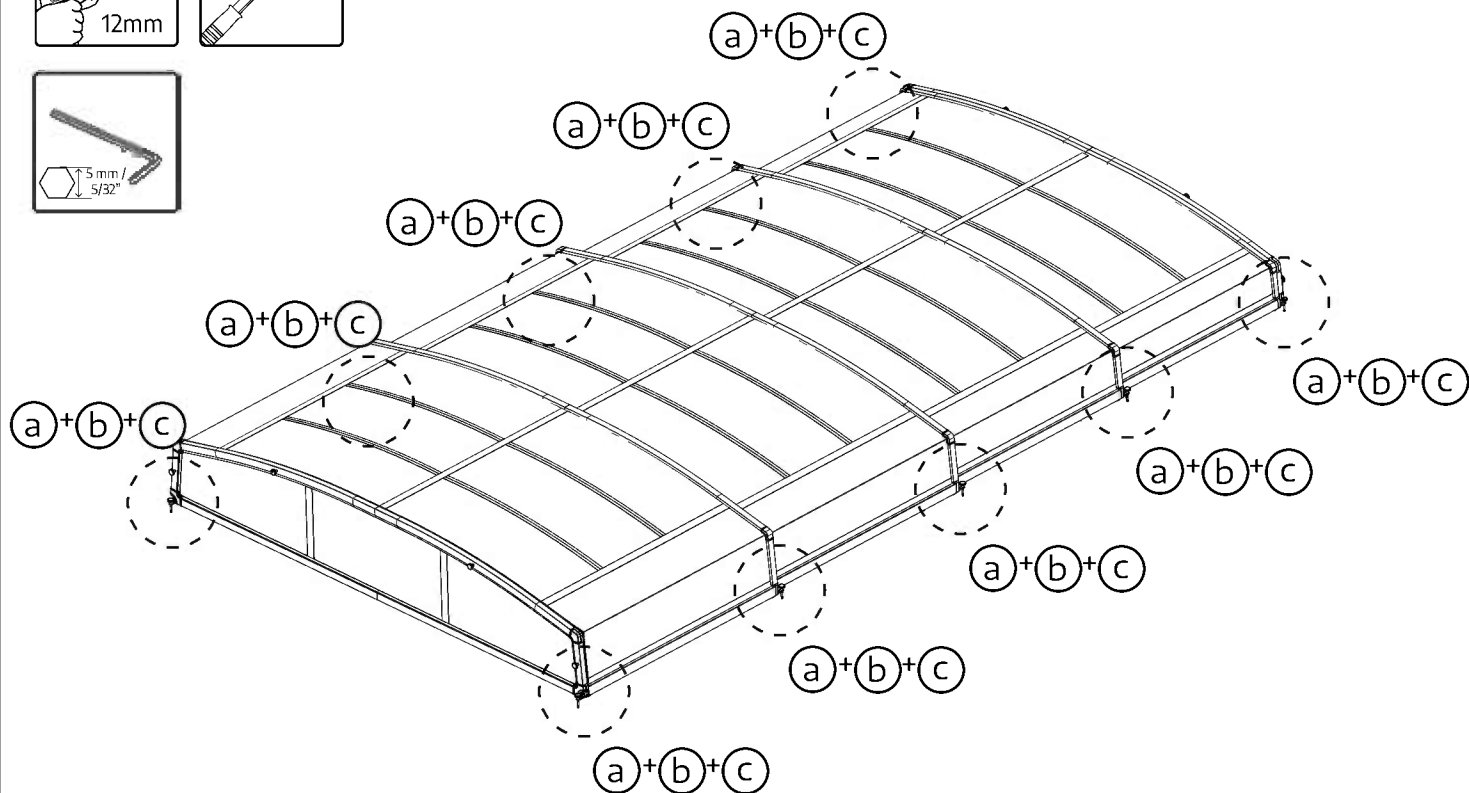
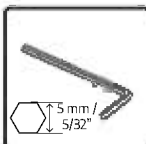
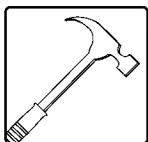



In Diagram **c** part **#9488** should be locked by pushing and screwing.

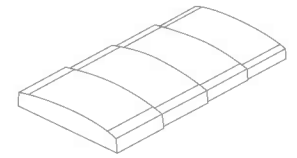

9213

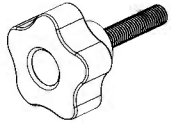

8

9488

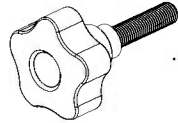

2

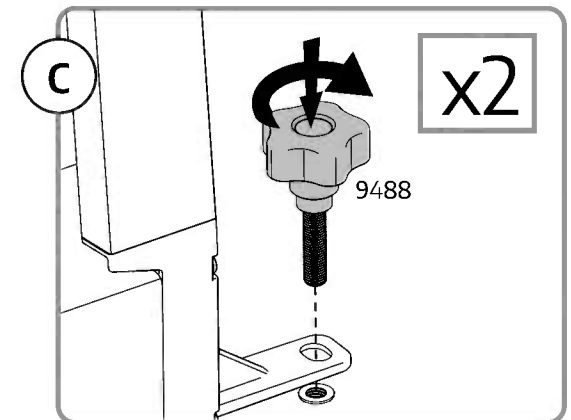
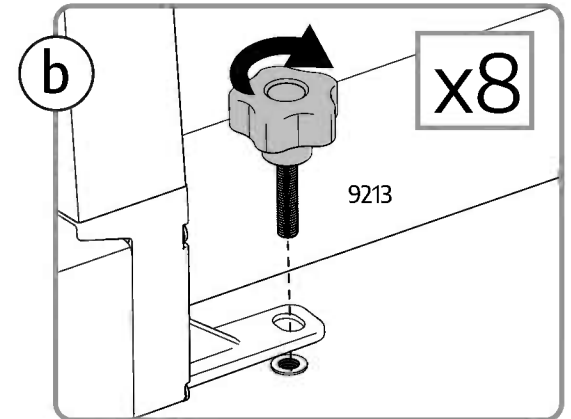
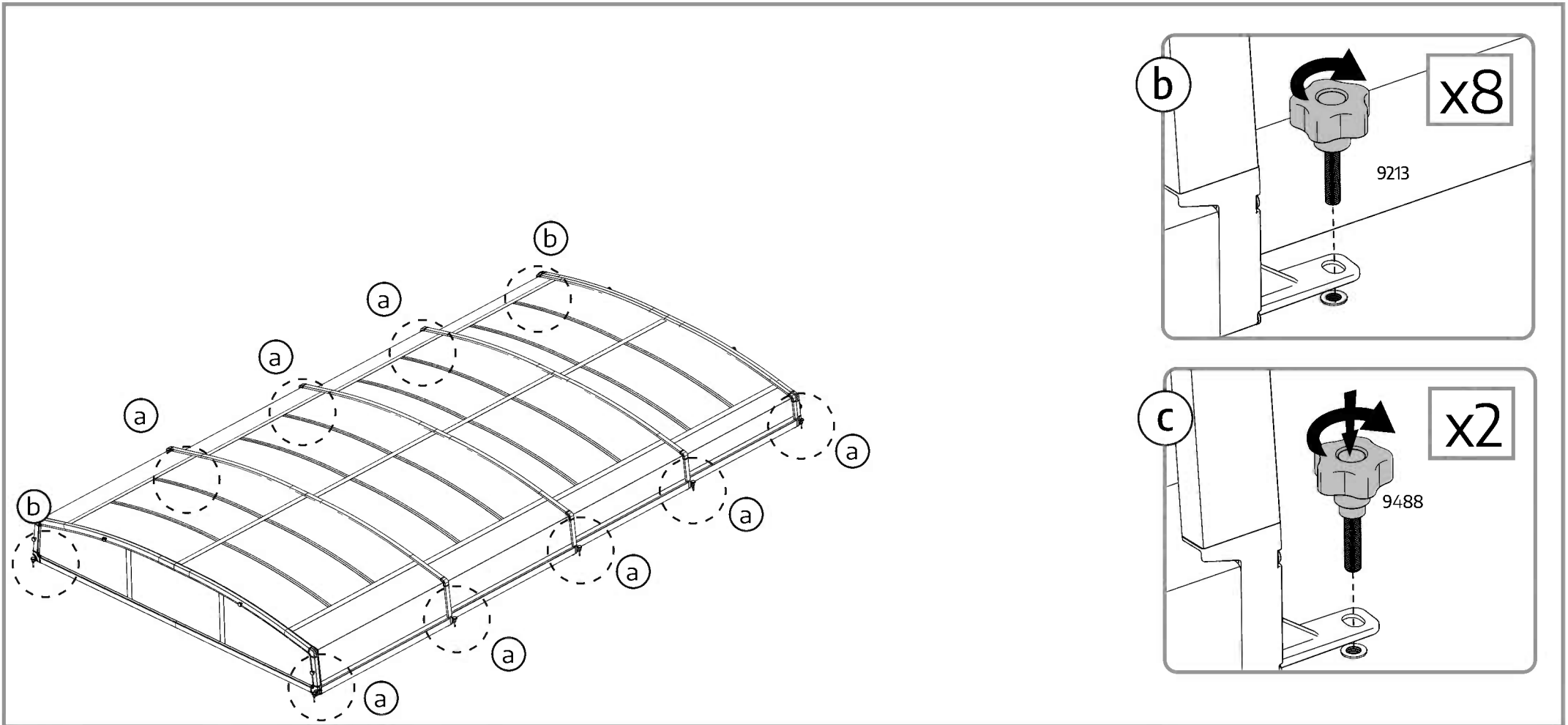

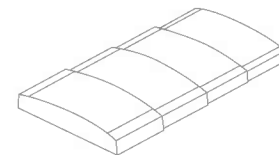

834817 84791

A parts list for step 100. It shows two items: a curved track labeled '834817' and a rectangular track labeled '84791'. Each item is accompanied by a circular inset showing a cross-section of the track.

A series of three diagrams illustrating the installation of the pool cover tracks. The first diagram shows the curved track (8348) being inserted into the pool cover's frame. A circular inset shows a close-up of the track fitting into a slot. A scissors icon is present in the top left. The second diagram shows the rectangular track (8479) being inserted into the pool cover's frame. A circular inset shows a close-up of the track fitting into a slot. The third diagram shows the curved track (8348) being inserted into the pool cover's frame. A circular inset shows a close-up of the track fitting into a slot. A scissors icon is present in the top left.

EN

PALRAM - CANOPIA | 10 YEAR LIMITED WARRANTY

Palram Canopia Ltd. (Company number: 512106824) whose registered office is at Teradion Industrial Park, M.P. Misgav 2017400, Israel ("Canopia") warrants that the product will be free from defects in material or workmanship for a period of 10 years from the original date of purchase. • This warranty is valid only if the product is installed, handled, cleaned, and maintained in accordance with Canopia's written specifications. • This warranty does not cover defects resulting from normal wear and tear including, but not limited to: damage caused by use of force, incorrect handling, inappropriate use, negligence, accidents, impact from foreign objects, vandalism, pollutants, alteration, painting, damage resulting from cleaning with incompatible detergents or minor deviations of the product. • This warranty does not apply to damage resulting from "acts of Nature", which includes but is not limited to hail, storm, tornado, hurricane, blizzard, flood, or fire. • Upon submitting proof of purchase and evidence of the claimed product failure, and subject to reporting the failure in writing within 30 days after discovery of the defect, Canopia, at its sole discretion, will replace defective parts of the Product, or refund you a prorated portion of the purchase price on a straight-line depreciated basis for the length of the warranty.

FR

GARANTIE LIMITÉE À 10 ANS DE PALRAM - CANOPIA

Palram Canopia Ltd. (Compagnie n° 512106824) dont le siège social est adressé au Parc Industriel Teradion, M.P. Misgav 2017400, Israël ("Canopia") garantit que le produit est exempt de tout défaut de matériau ou de fabrication pendant une période de 10 ans à compter de la date d'achat initiale. • Cette garantie n'est valable que si le produit est installé, manipulé, nettoyé et entretenu conformément aux spécifications établies par écrit de Canopia. • Cette garantie ne couvre pas les défauts résultant de l'usage normale, y compris, mais sans s'y limiter, les suivants : dommages causés par le forçage du produit, une mauvaise manipulation, une utilisation incorrecte, la négligence, les accidents, l'impact de corps étrangers, le vandalisme, les contaminants, les modifications, l'application de peinture, le nettoyage avec des détergents incompatibles ou les modifications mineures du produit. • Cette garantie ne s'applique pas aux dommages résultant de "catastrophes naturelles", y compris, mais sans s'y limiter, la grêle, les tempêtes, les tornades, les ouragans, les blizzards, les inondations ou les incendies. • Sur présentation de la preuve d'achat du Produit ainsi que de la preuve de la défaillance alléguée, et à condition que vous signaliez la défaillance par écrit dans les 30 jours suivant la découverte du défaut, Canopia remplacera, à sa seule discrétion, les pièces défectueuses du produit ou vous remboursera une partie proportionnelle du prix d'achat sur une base d'amortissement linéaire pour la durée de la garantie.

DE

10 JAHRE BESCHRÄNKTE GARANTIE VON PALRAM - CANOPIA

Palram Canopia Ltd. (Firmennummer: 512106824) mit Sitz in Teradion Industrial Park, M.P. Misgav 2017400, Israel („Canopia“) garantiert, dass das Produkt für einen Zeitraum von 10 Jahren ab dem ursprünglichen Kaufdatum frei von Material- und Verarbeitungsfehlern ist. • Diese Garantie ist nur gültig, wenn das Produkt gemäß den schriftlichen Spezifikationen von Canopia installiert, behandelt, gereinigt und gewartet wird. • Diese Garantie deckt keine Defekte ab, die auf normalen Verschleiß zurückzuführen sind, einschließlich, aber nicht beschränkt auf: Schäden, die durch Gewaltanwendung, falsche Handhabung, unsachgemäßen Gebrauch, Fahrlässigkeit, Unfälle, Einwirkungen von Fremdkörpern, Vandalismus, Schadstoffe, Veränderungen, Anstriche, Schäden, die durch Reinigung mit unverträglichen Reinigungsmitteln entstanden sind, oder geringfügige Abweichungen des Produkts. • Diese Garantie gilt nicht für Schäden, die durch „höhere Gewalt“ entstanden sind, wie z. B. Hagel, Sturm, Tornado, Orkan, Schneesturm, Überschwemmung oder Feuer. • Bei Einreichung des Kaufbelegs und des Nachweises des beanstandeten Produktfehlers und vorbehaltlich der schriftlichen Meldung des Fehlers innerhalb von 30 Tagen nach Entdeckung des Fehlers ersetzt Canopia nach eigenem Ermessen die fehlerhaften Teile des Produkts oder erstattet Ihnen einen anteiligen Teil des Kaufpreises auf linearer Abschreibungsbasis für die Dauer der Garantie.

ES

GARANTÍA LIMITADA DE 10 AÑOS DE PALRAM - CANOPIA

Palram Canopia Ltd. (Número de la compañía: 512106824) cuya oficina registrada se encuentra en Teradion Industrial Park, M.P. Misgav 2017400, Israel ("Canopia") garantiza que el producto estará libre de defectos de material o de fabricación durante un periodo de 10 años a partir de la fecha inicial de compra. • Esta garantía solo es válida si el producto se instala, manipula, limpia y mantiene de acuerdo con las especificaciones por escrito de Canopia. • Esta garantía no cubre los defectos resultantes del desgaste normal, entre lo que se incluye, entre otras cosas, lo siguiente: daños causados al forzar el producto, al manipularlo de forma incorrecta, al emplearlo de forma inapropiada, por negligencia, por accidentes, por impactos de objetos extraños, por vandalismo, por contaminantes, por modificaciones, por haber sido pintado, por la limpieza con detergentes incompatibles o por pequeñas modificaciones del producto. • Esta garantía no se aplica a los daños que resulten de "fenómenos naturales", lo que incluye, pero no se limita, al granizo, las tormentas, los tornados, los huracanes, las ventiscas, las inundaciones o los incendios. • Al presentar el comprobante de compra del producto así como una prueba de la falla que se reclama, y a condición de reportar la falla por escrito dentro de los 30 días siguientes al descubrimiento del defecto, Canopia, a su sola discreción, sustituirá las partes defectuosas del Producto, o le reembolsará una porción prorrateada del precio de compra de acuerdo a una base de depreciación lineal según la duración de la garantía.

SV

BEGRÄNSNINGAR I PALRAM - CANOPIA 10-ÅRS GARANTI

Palram Canopia Ltd. (Bolagsnummer: 512106824) vars registrerade huvudkontor har adressen: Teradion Industrial Park, M.P. Misgav 2017400, Israel ("Canopia") garanterar att produkten är fri från material- och tillverkningsfel under en period av 10 år från det ursprungliga inköpsdatumet. • Garantin gäller endast om produkten installeras, hanteras, rengörs och underhålls i enlighet med Canopias skriftliga specifikationer. • Garantin täcker inte defekter som beror på normalt slitage, inklusive, men inte begränsat till: skador som orsakats av våld, felaktig hantering, olämplig användning, vårdslöshet, olyckor, påverkan från främmande föremål, vandalism, föroreningar, ändring, målning, skador som orsakats av rengöring med inkompatibla rengöringsmedel eller smärre avvikelser av produkten. • Denna garanti gäller inte för skador till följd av "naturkatastrofer", vilket inkluderar men inte är begränsat till hagel, storm, tornado, orkan, snöstorm, översvämning eller brand. • Mot uppvisande av inköpsbevis och bevis för det påstådda produktfelet, och under förutsättning att felet rapporteras skriftligen inom 30 dagar efter upptäckten av felet, kommer Canopia, efter eget gottfinnande, att byta ut defekta delar av produkten eller återbetala dig en proportionell del av inköpspriset på linjär avskrivningsbasis under garantins längd.

NN

PALRAM - CANOPIAS 10 ÅRS BEGRENSEDE GARANTI

Palram Canopia Ltd. (Selskapsnummer: 512106824) med hovedkontor i Teradion Industrial Park, M.P. Misgav 2017400, Israel ("Canopia") garanterer at produktet vil være uten defekter i materiale eller utførelse i en periode på 10 år fra den opprinnelige kjøpsdatoen. • Denne garantien gjelder bare hvis produktet er installert, håndtert, rengjort og vedlikeholdt i henhold til Canopias skriftlige spesifikasjoner. • Denne garantien dekker ikke feil som skyldes normal slitasje, inkludert, men ikke begrenset til: skade forårsaket av bruk av makt, feil håndtering, upassende bruk, uaktsomhet, ulykker, påvirkning fra fremmedlegemer, hærverk, miljøgifter, endring, maling, skade som følge av rengjøring med inkompatible vaskemidler eller mindre avvik i produktet. • Denne garantien gjelder ikke for skader som følge av naturfenomener, inkludert, men ikke begrenset til, hagl, storm, tornado, orkan, snøstorm, flom eller brann. • Ved innlevering av kvittering på kjøp og bevis på den påståtte produktfeilen, og med forbehold om skriftlig rapportering av feilen innen 30 dager etter oppdagelsen av feilen, vil Canopia, etter eget skjønn, erstatte defekte deler av produktet, eller refundere deg en del av kjøpesummen beregnet ved bruk av lineær metode på grunnlag av garantiens varighet.

FI

PALRAM - CANOPIA 'N I 10 VUODEN RAJOITETUT TAKUUEHDOT

Palram Canopia Ltd. (yhtiön rek.nro 512106824) jonka päätoimipiste toimii osoitteessa Teradion Industrial Park, M.P Misgav 2017400, Israel. ("Canopia") takaa, että tuotteesta ei ole materiaali- tai valmistusvirheitä 10 vuoden ajan alkuperäisestä ostopäivästä. • Tämä takuu on voimassa vain, jos tuote on asennettu, sitä on käsitelty, puhdistettu ja huollettu Canopian kirjallisten ohjeiden mukaisesti. • Tämä takuu ei kata vikoja, jotka johtuvat normaalista kulumisesta, mukaan lukien mutta rajoittumatta: voimankäytöstä aiheutuneet vahingot, väärä käsittely, sopimaton käyttö, huolimattomuus, onnettomuudet, vierasesineiden törmäykset, ilkivalta, saasteet, muutokset, maalaus, vauriot jotka johtuvat puhdistuksesta yhteensopimattomilla pesuaineilla, tai tuotteen vähäisistä poikkeamista. • Tämä takuu ei koske vaurioita, jotka johtuvat luonnonvoimista, joihin kuuluvat muun muassa rakeet, myrsky, tornado, hurrikaani, lumimyrsky, tulva tai tulipalo. • Canopia oman harkintansa mukaan vaihtaa vialliset tuotteen osat tai palauttaa sinulle tuotteen vialliset osat toimitettuasi ostotodistuksen ja todisteet väitetystä tuotteen viasta ja ilmoittamalla virheestä kirjallisesti 30 päivän kuluessa vian havaitsemisesta, tai hyvittää sinulle suhteellisen osuuden ostohinnasta laskettuna tasapoistoina kuluneen takuuaajan mukaisesti.

DA

PALRAM - CANOPIAS I 10 ÅRS BEGRÆNSET GARANTI

Palram Canopia Ltd. (Virksomhedsregistreringsnummer: 512106824), registreret på adressen Teradion Industrial Park, M.P Misgav 2017400, Israel ("Canopia"), garanterer, at produktet vil være uden defekter i materiale eller udførelse i en periode på 10 år fra den oprindelige købsdato. • Denne garanti gælder kun, hvis produktet er installeret, håndteret, rengjort og vedligeholdt i overensstemmelse med Canopias skriftlige specifikationer. • Denne garanti dækker ikke defekter, der skyldes normal slitage, herunder, men ikke begrænset til: skader forårsaget af magtanvendelse, forkert håndtering, forkert brug, uagtsomhed, ulykker, udsættelse for fremmedlegemer, hærværk, miljøgifte, ændring, maling, skader som følge af rengøring med uforenelige rengøringsmidler eller mindre afvigelser i produktet. • Denne garanti dækker ikke skader som følge af naturfænomener, herunder, men ikke begrænset til, hagl, storm, tornado, orkan, snestorm, oversvømmelse eller brand. • Ved fremsendelse af en kvittering for køb og bevis for den påståede produktfejl, og med forbehold for skriftlig indberetning af defekten inden for 30 dage efter opdagelsen af defekten, vil Canopia efter eget skøn udskifte defekte dele af produktet, eller refundere dig en del af købsprisen beregnet ved hjælp af den lineære metode på grundlag af garantiens varighed.

NL

PALRAM - CANOPIA'S I 10 JAARS BEPERKTE GARANTIE

Palram Canopia Ltd. (Bedrijfsnummer: 512106824) met maatschappelijke zetel te Teradion Industrial Park, M.P Misgav 2017400, Israël ("Canopia") garandeert dat het product vrij zal zijn van materiaal- of fabricagefouten gedurende een periode van 10 jaar vanaf de oorspronkelijke aankoopdatum. • Deze garantie is alleen geldig als het product wordt geïnstalleerd, gehanteerd, gereinigd en onderhouden in overeenstemming met de schriftelijke specificaties van Canopia. • Deze garantie dekt geen defecten die het gevolg zijn van normale slijtage, waaronder, maar niet beperkt tot: schade veroorzaakt door het gebruik van geweld, onjuist gebruik, nalatigheid, ongevallen, impact van vreemde voorwerpen, vandalisme, verontreinigende stoffen, wijziging, beschouwing, schade als gevolg van reiniging met onverenigbare detergentia of kleine afwijkingen van het product. • Deze garantie is niet van toepassing op schade die het gevolg is van "natuurrampen", waaronder maar niet beperkt tot hagel, storm, tornado, orkaan, sneeuwstorm, overstroming of brand. • Na het indienen van het aankoopbewijs en het bewijs van het geclaimde productfalen, en onder voorbehoud van het schriftelijk melden van het falen binnen 30 dagen na ontdekking van het defect, zal Canopia, naar eigen goeddunken, defecte onderdelen van het product vervangen of u een pro rata deel van de aankoopprijs terugbetalen op een lineaire afschrijvingsbasis voor de duur van de garantie.

IT

GARANZIA LIMITATA 10 ANNI I PALRAM - CANOPIA

Palram Canopia Ltd. (società numero: 512106824) i cui uffici registrati hanno sede a Teradion Industrial Park, M.P Misgav 2017400, Israele ("Canopia") garantisce che il prodotto è privo di difetti di materiale o di lavorazione per un periodo di 10 anni dalla data di acquisto iniziale. • La garanzia è valida solo se il prodotto viene installato, trattato, pulito e sottoposto a manutenzione in conformità alle specifiche scritte di Canopia. • Questa garanzia non copre i difetti derivanti dalla normale usura, inclusi, ma non solo, i seguenti: danni causati da forzature del prodotto, uso improprio, negligenza, incidenti, impatto di oggetti estranei, vandalismo, contaminazione, modifiche, verniciatura, pulizia con detergenti incompatibili o modifiche minori del prodotto. • Questa garanzia non si applica ai danni derivanti da "cause di forza maggiore", tra cui, a titolo esemplificativo, grandine, tempeste, tornado, uragani, bufere, inondazioni o incendi. • Su presentazione della prova d'acquisto del Prodotto e della prova del presunto guasto, e a condizione che lei denunci il guasto per iscritto entro 30 giorni dalla scoperta del difetto, Canopia, a sua esclusiva discrezione, sostituirà le parti difettose del Prodotto o rimborserà una parte proporzionale del prezzo d'acquisto sulla base di un ammortamento lineare per la durata della garanzia.

SK

10-ROČNÁ OBMEDZENÁ ZÁRUKA I PALRAM - CANOPIA

Palram Canopia Ltd. (číslo spoločnosti: 512106824), ktorej sídlo je v priemyselnom parku Teradion, M.P Misgav 2017400, Izrael ďalej len („Canopia“) zaručuje, že výrobok bude bez väd materiálu alebo spracovania po dobu 10 rokov od pôvodného dátumu nákupu. • Táto záruka platí len vtedy, ak je výrobok nainštalovaný, je s ním manipulované, je čistený a udržiavaný v súlade s písomnými špecifikáciami spoločnosti Canopia. • Táto záruka sa nevzťahuje na chyby vyplývajúce z bežného opotrebovania vrátane, ale nie výlučne: poškodenie spôsobené použitím sily, nesprávnou manipuláciou, nevhodným používaním, nedbalosťou, nehodami, nárazom cudzích predmetov, vandalizmom, znečisťujúcimi látkami, úpravou, náterom, poškodením v dôsledku čistenia nekompatibilnými čistiacimi prostriedkami alebo drobnými odchýlkami výrobu. • Táto záruka sa nevzťahuje na škody spôsobené "prírodnými udalosťami", ktoré zahŕňajú okrem iného krupobitie, búrku, tornádo, hurikán, víchricu, povodeň alebo požiar. • Po predložení dokladu o kúpe a dôkazu o reklamovanej poruche výrobu a na základe písomného nahlásenia poruchy do 30 dní od zistenia poruchy vám spoločnosť Canopia podľa vlastného uváženia vymení chybné časti výrobu alebo vám vráti pomernú časť kúpnej ceny na základe rovnomerného odpisovania počas trvania záruky.

SL

10-LETNA OMEJENA GARANCIJA PODJETJA I PALRAM - CANOPIA

Podjetje Palram Canopia Ltd. (matična številka: 512106824), katerega sedež je na naslovu Teradion Industrial Park, M.P Misgav 2017400, Izrael podjetje ("Canopia"), jamči, da bo izdelek brez napak v materialu ali izdelavi za obdobje 10 let od prvotnega datuma nakupa. • Ta garancija velja le, če je izdelek nameščen, obdelan, očiščen in vzdrževan v skladu s pisnimi specifikacijami podjetja Canopia. • Ta garancija ne krije napak, ki so posledica običajne obrabe, vključno, vendar ne omejeno na: škodo, ki jo povzroči uporaba sile, nepravilno ravnanje, neprimerno uporabo, malomarnost, nesreče, udarce tujih predmetov, vandalizem, onesnaževala, spremembe, barvanje, škodo, ki je posledica čiščenja z nezdružljivimi detergenti ali manjša odstopanja izdelka. • Ta garancija ne velja za škodo, ki izhaja iz "naravnih pojavov", ki vključuje, vendar ni omejena na točo, nevihto, tornado, orkan, snežni metež, poplavo ali požar. • Po predložitvi dokazila o nakupu in dokazila o zatrevanju napaki izdelka ter ob pisni prijavi napake v 30 dneh po odkritju napake bo Palram - Canopia po lastni presoji zamenjal okvarjene dele izdelka ali vam povrnil sorazmerni delež nakupne cene po metodi enakomernega časovnega amortiziranja za čas trajanja garancije.

