

DE Aufbauanleitung Gerätehaus „HighLine®“ Größe H1, H2

- Ⓞ GB Assembly manual for garden shed „Highline®“ size H1, H2
- Ⓞ FR Notice de montage pour l’abri de jardin „HighLine®“ taille H1, H2
- Ⓞ NL Opbouwbeschrijving berging „Highline®“ grotte H1, H2
- Ⓞ IT Istruzioni di montaggio Casetta portattrezzi “Highline®” misura H1, H2
- Ⓞ ES Instrucciones de montaje de la caseta modelo “HighLine®” tamaño H1, H2



Wichtige Punkte für den Aufbau!

Vorliegende Aufbauanleitung zeigt den Zusammenbau von „HighLine“ Größe „H2“; sie gilt sinngemäß auch für die Größe „H1“. Für einige Montageschritte benötigen Sie 1 bis 2 Helfer.

- (GB)** *Important details regarding assembly! This assembly manual shows the erection of the garden shed model "HighLine" size "H1"; it is also valid for size "H2" For several assembly steps additional assistance of 1 or 2 people will be required.*
- (FR)** *Points importants lors du montage! " Cette notice de montage décrit l'assemblage de l'abri „HighLine“ taille « H1 »; celle-ci est aussi valable pour la taille « H2 ». Pour certaines étapes, demandez l'aide d'une ou deux personnes.*
- (NL)** *Deze montage instructies hebben betrekking op de opbouw van de Highline , grootte H1. De instructies zijn ook van toepassing op de grootte H2. Voor enkele montage stappen heeft u 1 of 2 extra mensen nodig.*
- (ES)** *Notas importantes para el montaje: Estas instrucciones muestran el montaje de la caseta "HighLine" en tamaño H1. También son válidas para el tamaño H2. Es recomendable realizar el montaje entre dos o tres personas.*
- (IT)** *Indicazioni importanti per il montaggio! Le seguenti istruzioni di montaggio fanno riferimento all'assemblaggio di „HighLine“ misura „H1“; per analogia sono valide anche per la misura „H2“. Per alcune fasi di assemblaggio vi serviranno 1 - 2 aiutanti.*

Um Kratzer zu vermeiden, verwenden Sie bitte geeignete Unterlagen!

- (GB)** *Please use a suitable underlay to avoid scratches!*
- (FR)** *Pour éviter les rayures, utilisez les supports appropriés!*
- (NL)** *Om krassen te voorkomen raden wij u aan er iets onder te leggen!*
- (ES)** *Por favor, coloque en el suelo una base protectora adecuada para evitar posibles arañazos.*
- (IT)** *Utilizzare una base adatta per evitare graffi!*

Schraubenverbindungen grundsätzlich erst am Ende der Montage festziehen!

- (GB)** *Nuts not to be tightened before the end of assembly!*
- (FR)** *Ne serrer les écrous à fond qu'à la fin du montage!*
- (NL)** *Schroeven pas aan het einde van de montage vastdraaien!*
- (ES)** *En principio, no apriete fijamente las tuercas hasta que no haya terminado de montar la caseta.*
- (IT)** *I dadi devono essere serrati a fondo soltanto alla fine del montaggio!*

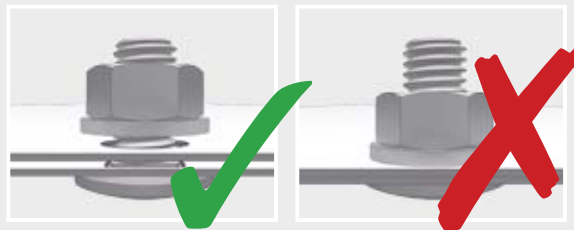

Einbaumöglichkeiten der Türen anstelle von Wandelementen!

- (GB)** *The door can be installed instead of a side wall element!*
- (FR)** *La porte peut être installée sur le côté à la place d'une paroi latérale!*
- (NL)** *Inbouwmogelijkheden van de deuren i.p.v. de wandelementen*
- (ES)** *Es posible colocar las puertas en lugar de los paneles laterales.*
- (IT)** *Considerare la possibilità di montare una porta standard al posto di una parete laterale!*

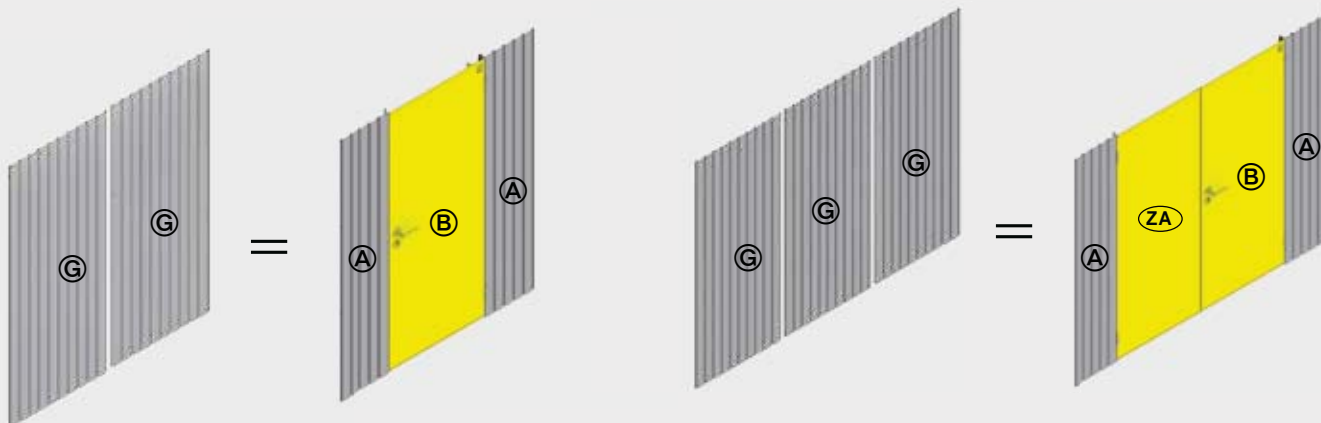



Nicht bei Wind aufbauen!

- (GB) Do not assemble the shed on a windy day!
- (FR) Ne pas assembler quand il y a du vent !
- (NL) Niet bij wind opbouwen!

- (ES) No monte la caseta si hace mucho viento.
- (IT) Non montare la casetta in giornate di vento!



Verwenden Sie bei der Montage Arbeitshandschuhe!

- (GB) Wear working gloves!
- (FR) Portez des gants de travail
- (NL) Handschoenen gebruiken!

- (ES) Utilice unos guantes de trabajo.
- (IT) Utilizzare guanti da lavoro



Optionales Zubehör - Symbol:

Arbeitsschritte die blau eingerahmt sind, zeigen den Einbau eines optionalen Zubehörteiles.

- (GB) Symbol of optional accessories: Blue framed assembly steps show the installation of optional accessories.
- (FR) Accessoires en option-Symbole: La trame entourée en bleu indique une étape avec accessoires en option. A réaliser uniquement si vous avez commandé cet accessoire.
- (NL) Extra Toebehoor: Montageschappen met een blauwe rand betreffen de inbouw van extra toebehoor.
- (ES) Accesorio opcional - símbolo: Los pasos de montaje que se encuentran enmarcados en azul muestran el montaje de una pieza de un accesorio opcional.
- (IT) Simbolo per accessori opzionali: Le fasi del montaggio incorniciate in colore azzurro mostrano l'installazione di un accessorio opzionale.



optionales Zubehör - Accesso...

Bodenrahmen

(Floor Frame - Cadri



Wasserwaagen - Symbol:

Betreffendes Einbauteil mit der Wasserwaage ausrichten.

- (GB) Symbol of spirit level: Align the respective parts by using the spirit level.
- (FR) Symbole niveau à bulle: Lorsque ce symbole apparaît, vous devez ajuster l'élément à l'aide d'un niveau à bulle.
- (NL) Waterpas - symbol: Bij montageschappen waar dit symbool bijstaat is het noodzakelijk het betreffende onderdeel waterpas in te bouwen.
- (ES) Símbolo del nivelador: Indica que se debe ajustar y centrar la pieza con la ayuda de un nivelador.
- (IT) Simbolo di livella a bolla d'aria: Allineare il componente in questione con l'ausilio di una livella a bolla d'aria.

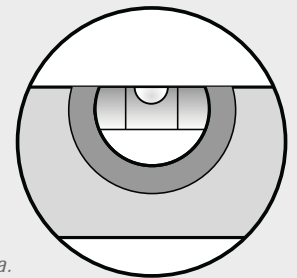

Maßstabsgetreue Abbildungen der zu verwendenden Schrauben:

- (GB) Scale drawing 1:1 of the screws in use
- (FR) Reproduction selon l'échelle 1:1.
- (NL) Afbeelding : schaal 1:1 (ware grootte)

- (ES) Reproducción a escala 1:1 de los tornillos que se utilizan para el montaje.
- (IT) Immagine in scala delle viti da utilizzare!

M 1:1

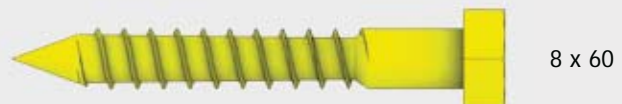

8 x 60



M8 x 90



4,8 x 9,5 4,8 x 13 M5 x 12 M4 x 10 M4 x 18 M5 x 10 M5 x 18 M5 x 16 M8 x 16

Pflege und Wartung

- Keine aggressiven Chemikalien wie z.B. Chlor oder Streusalz offen lagern!
- Sonnenmilch und andere Cremen mit Wasser und Seife entfernen
- Keine scheuernden Reinigungsmittel verwenden!
- Laub von Dach regelmäßig entfernen!
- Dachrinnenauslauf kontrollieren
- Tiefe Kratzer sofort mit beiliegendem Lack ausbessern!
- Ölen Sie das Schloß jährlich!

(EN) Care and maintenance

- *Do not store aggressive substances uncovered i.e. chlorine or road salt*
- *Remove suntan lotion or any other creams with water and rinse aid!*
- *Do not use abrasive cleaning agents!*
- *Keep the roof free of leaves!*
- *Check the gutter*
- *Touch-up scratches immediately with the paint provided.*
- *Lubricate the lock once a year!*

(FR) Entretien et maintenance

- *Ne pas stocker de produits chimiques (chlore, sel, etc...)*
- *Nettoyez uniquement avec de l'eau les crèmes solaires et autres crèmes (pas de nettoyant chimique).*
- *Ne pas utiliser de produits nettoyant abrasifs!*
- *Débarrassez vous régulièrement des feuilles mortes sur le toit !*
- *Corrigez immédiatement les rayures avec la laque jointe!*
- *Graissez la serrure et les charnières chaque année !*

(NL) Onderhoud

- *Geen chemicaliën om de berging opslaan*
- *Zonnebrandolie/melk en andere cremes met water en glansmiddel verwijderen*
- *Gebruik geen schuurmiddelen!*
- *Regelmatig bladeren van dak verwijderen!*
- *Krassen direct met de meegeleverde lak behandelen*
- *Slot jaarlijks oliën*

(ES) Cuidado y mantenimiento

- *No almacene productos químicos agresivos dentro de la caseta como por ejemplo cloro y sal antiescarcha.*
- *Evite dejar huellas o restos de cremas solares sobre la chapa. Limpie la caseta siempre con agua o un trapo húmedo.*
- *No utilice ningún producto para fregar. En general, evite siempre cualquier producto químico para limpiar la caseta.*
- *Mantenga el tejado libre de hojas secas.*
- *Repare los arañazos lo antes posible con el barniz que se incluye*
- *Aplique aceite en la cerradura y las bisagras una vez al año*

(IT) Manutenzione

- *Non lasciare prodotti chimici aggressivi (come ad esempio cloro o sale per strade) all'interno della casetta!*
- *Rimuovere crema solare e altre creme con acqua e brillantante!*
- *Non utilizzare detergenti contenenti sostanze aggressive!*
- *Mantenere il tetto libero da foglie!*
- *Ritoccare immediatamente eventuali graffi con la vernice fornita nella confezione!*
- *Lubrificare la serratura e le cerniere a cadenza annuale!*

Vorschläge für das Fundament

Bitte achten Sie bei der Fundamentgestaltung darauf, dass Niederschlagswasser nicht seitlich unter den Bodenprofilen in das Gerätehaus eindringen kann! (siehe Varianten 1, 2, 3). Aufsteigende Bodenfeuchtigkeit und Kondensation vermeiden Sie mittels einer starken Kunststoffolie unter dem Betonfundament.

(GB) *Proposals for a secure foundation*

When making the foundation arrangements please take necessary precaution to ensure that water cannot leak in under the floor profiles (see option 1, 2, 3). Rising ground moisture and condensation can be avoided by using a strong plastic sheet underneath the paving slabs or underneath the concrete foundation.

(FR) *Conseils pour les fondations*

Lors de la réalisation de la fondation, veillez à ce que l'eau de pluie ne puisse pas pénétrer dans l'abri ou par les côtés sous les profils de sol (voir variantes 1,2,3). Vous pouvez éviter l'humidité du sol et la condensation en mettant un film plastique épais sous les plaques de béton.

(NL) *Voorstellen voor fundament*

Let er bij het maken van de fundering op dat regenwater niet onder het bodemprofiel kan doorlopen (zie voorbeeld 1,2,3). Een vochtige bodem en condensatie kunt u vermijden door het aanbrengen van een sterke kunststoffolie onder de tegels of het betonfundament.

(ES) *Medidas y recomendaciones para los cimientos:*

Al colocar los cimientos, asegúrese de que el agua de lluvia no puede penetrar en la caseta por los laterales debajo del perfil del suelo (véase variante 1,2 y 3). Evite la humedad y la condensación en el suelo colocando una lámina de plástico bajo las losas o los cimientos de hormigón.

(IT) *Proposte per il basamento:*

Il basamento deve essere progettato in modo da evitare infiltrazioni di acqua piovana all'interno della casetta (vedere proposta 1-2-3). Un telo di plastica spesso posto in corrispondenza dell'area di pavimento evita infiltrazioni di umidità dal terreno e la formazione di condensa.



Weitere Details betreffend Fundament finden Sie auch unter www.biohort.com/Fundament

Further details about foundations you will find on www.biohort.com/foundation

Pour détails supplémentaires veuillez consulter www.biohort.com/fondations

Verdere details over het fundament vindt u ook op www.biohort.com/fundament

Maße für das Fundament

(GB) Foundation dimensions

(ES) Medidas de los cimientos

(FR) Dimensions pour la fondation

(IT) Dimensioni del basamento

(NL) Maat voor het fundament

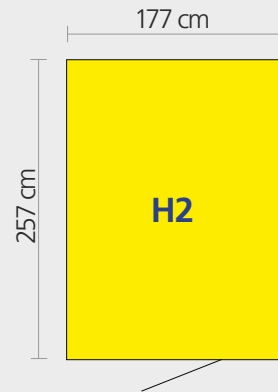
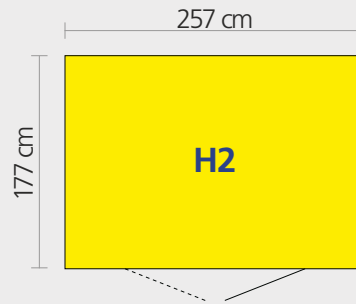
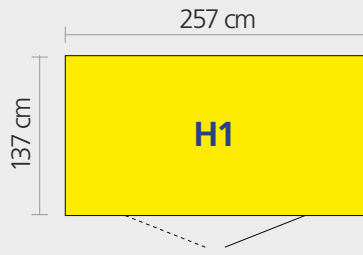

ACHTUNG ATTENTION
ATTENTION | ATTENTIE |
LET OP | ATENCIÓN |
ATTENZIONE



Die Verankerung ist wichtig, denken Sie an Sturmböen!

Do not forget to anchor the shed against gale force wind!

L'ancrage est important, pensez aux rafales de vent!

Verankering niet vergeten!

El anclaje es muy importante. Piense por ejemplo en rachas fuertes de viento.

L'ancoraggio della casetta è importante - pericolo in caso di raffiche di vento!

Variante, Proposal, Variant 1

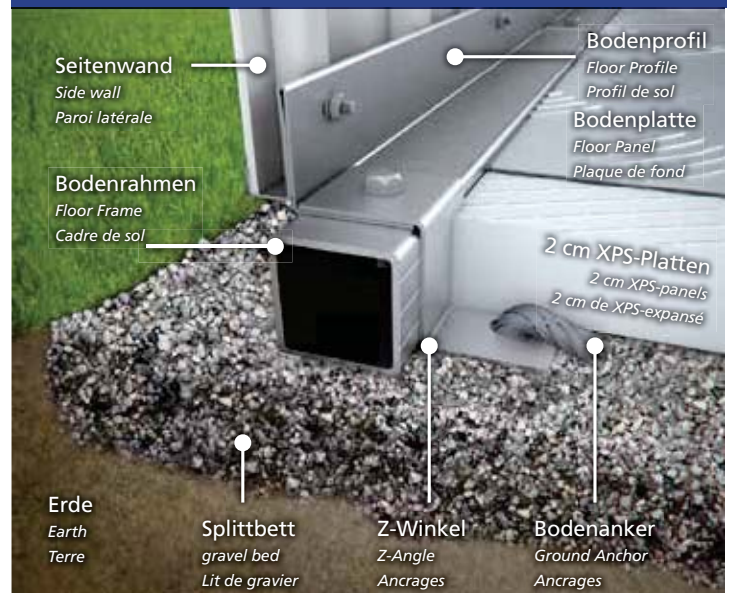

Variante, Proposal, Variant 2

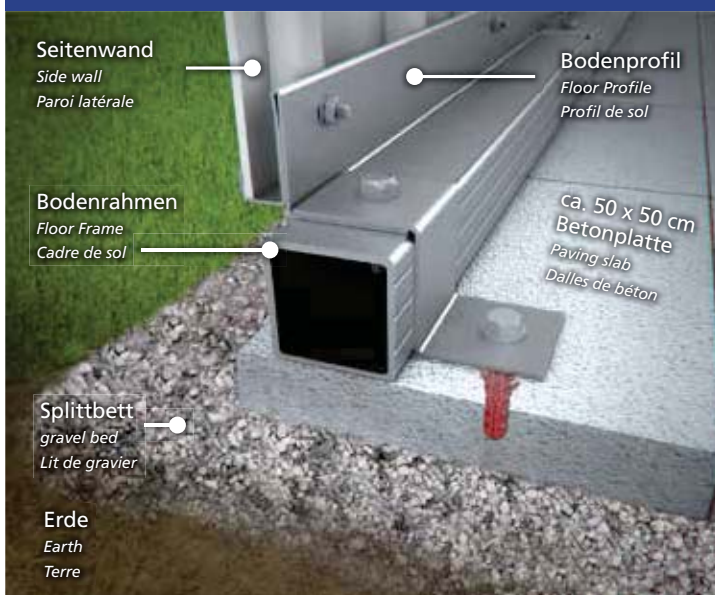

Variante, Proposal, Variant 3

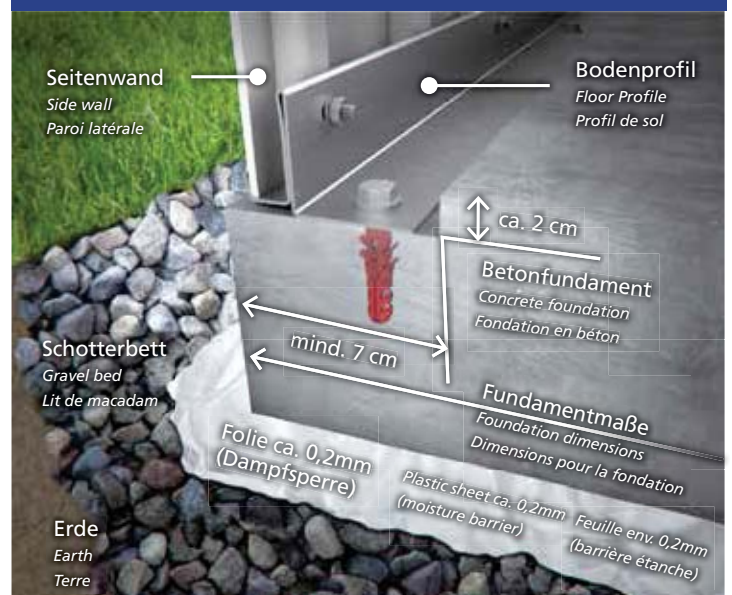

1 Paket Nr. 1

Türpaket · doorpackage · carton de portes · deurpakket · pacco pareti laterali · kit de puerta

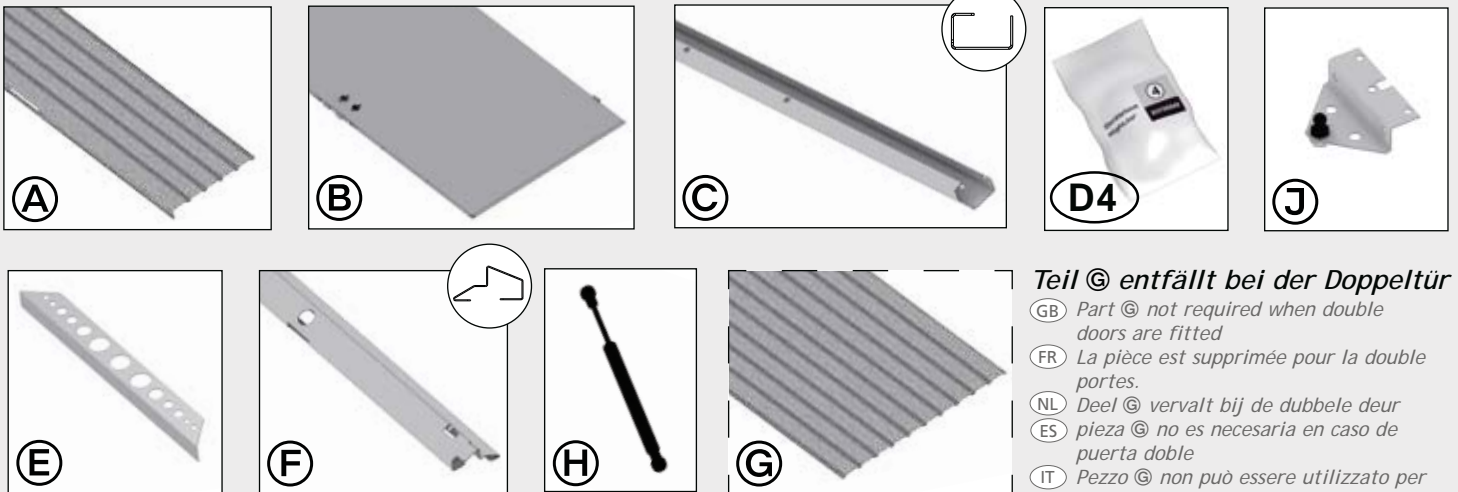

Teil © entfällt bei der Doppeltür

- (GB) Part © not required when double doors are fitted
- (FR) La pièce est supprimée pour la double portes.
- (NL) Deel © vervalt bij de dubbele deur
- (ES) pieza © no es necesaria en caso de puerta doble
- (IT) Pezzo © non può essere utilizzato per la variante porta a due battenti

Zusatzteile Doppeltür

(double door package · carton de double portes · dubbeldeurpakket · pacco porta doppia · kit de puerta adicional)

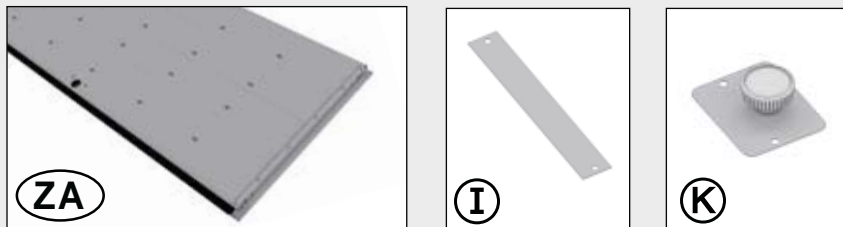

2 Paket Nr. 2

Seitenwandpaket · side panel package · carton de parois latérales · zijwandpakket · pacco pareti laterali · panel lateral



3 Paket Nr. 3

Profilpaket · profile package · carton de profils · profielpakket · pacco profili · kit de perfiles

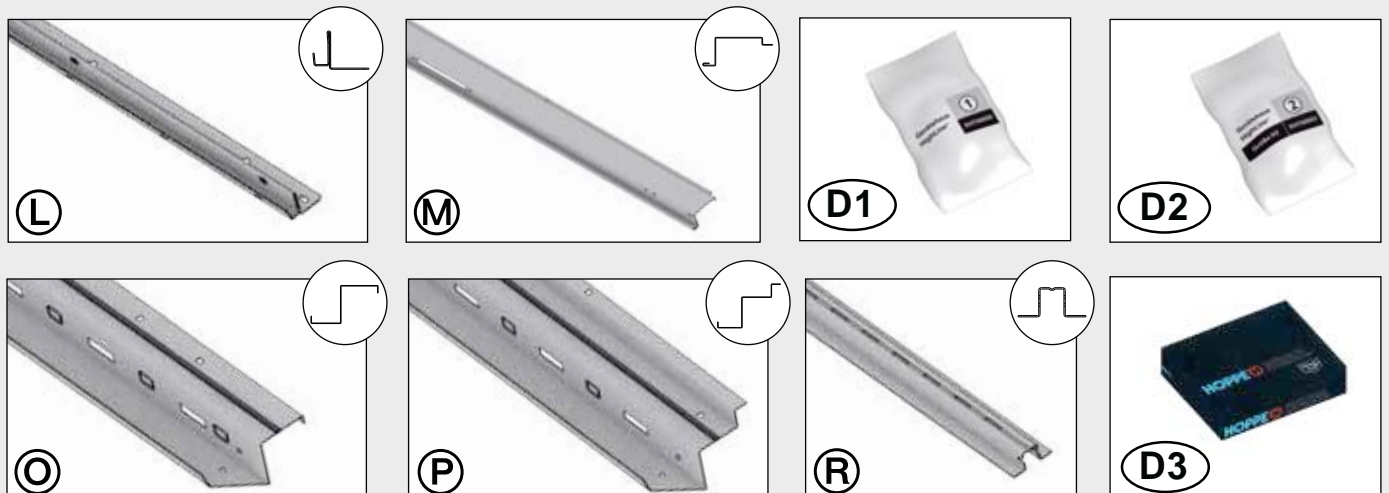

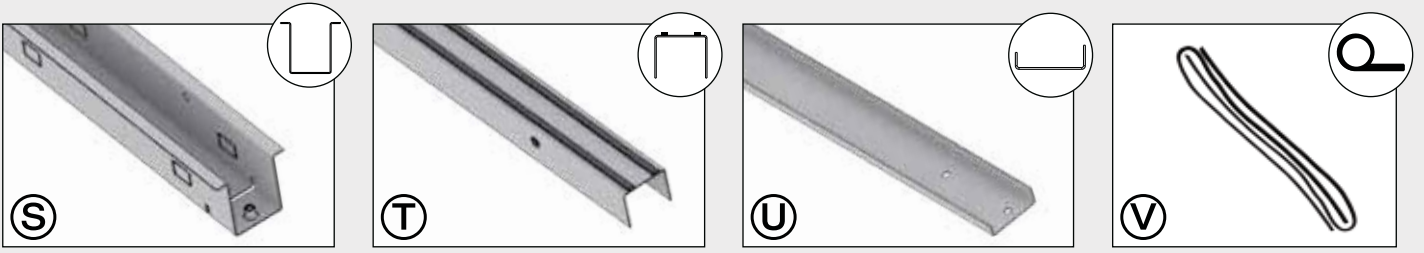

4 Paket Nr. 4
 Dach-Blechpaket · roof panel package · carton de tôles de toit · dakplaatpakket · pacco lamiera tetto · kit de tejado laminado

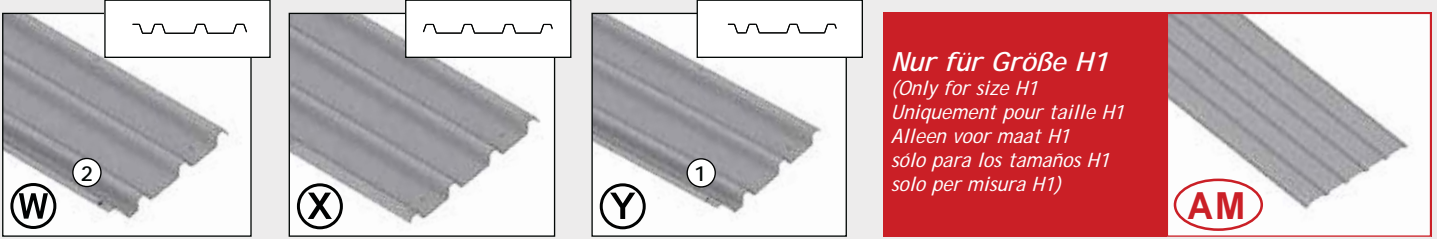

5 Paket Nr. 5
 Dach-Profilpaket · top profile package · carton de profils de toit · dakprofielpakket · pacco profili del tetto · kit de perfiles de tejado

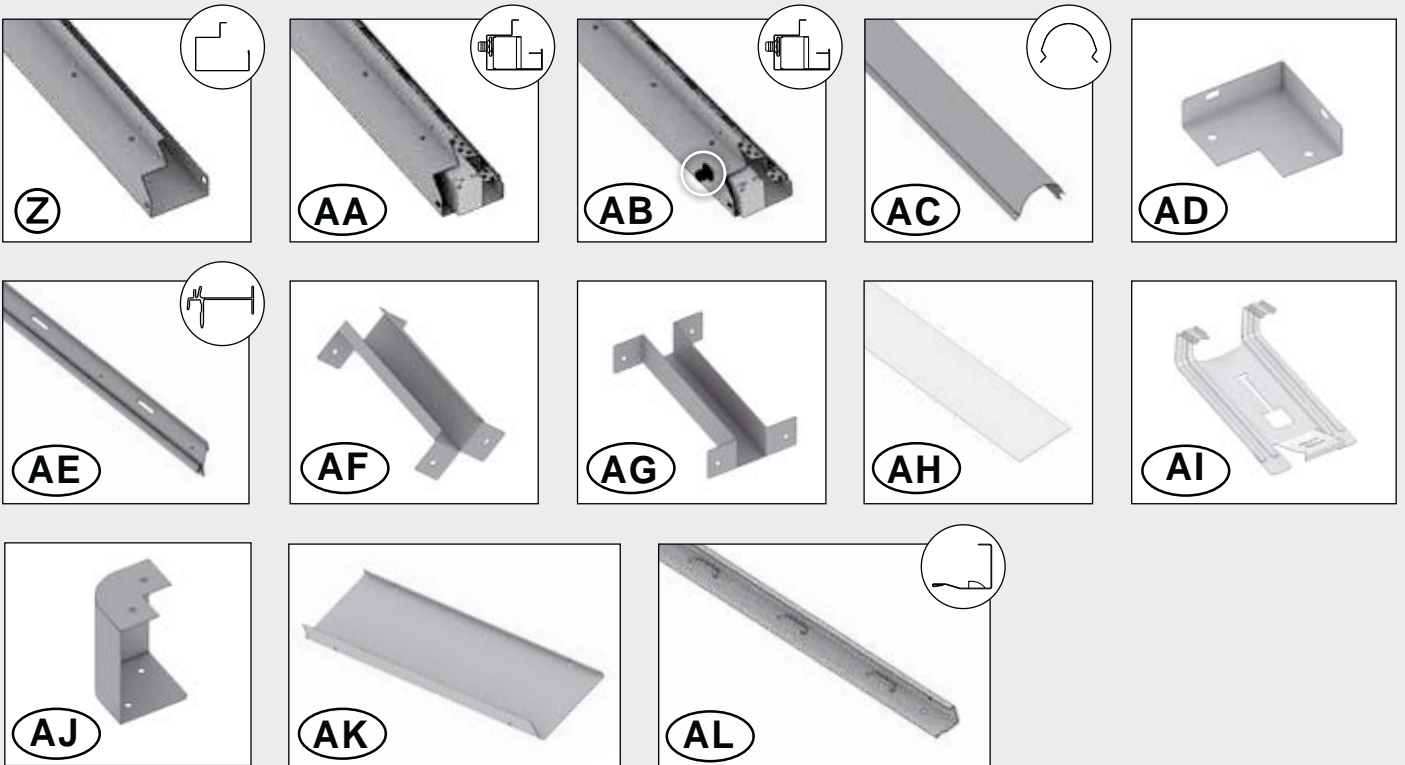

Bodenrahmen

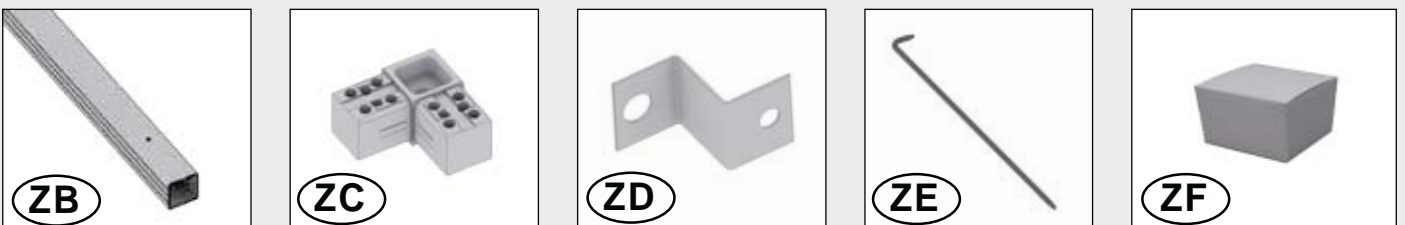

Floor Frame · Cadre de sol · Telaio perimetrale · Bodemframe · marco de suelo



Rückwand

Rear wall - Paroi arrière - Achterwand - panel posterior - Parete posteriore

1.

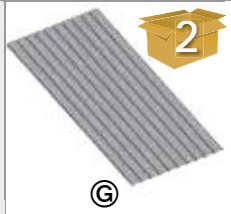
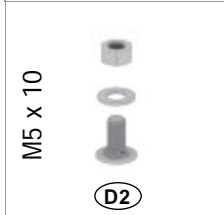
 <p>AE</p>	<p>H1: 1X (2510mm) H2: 1X (2510mm)</p>	 <p>L</p>	<p>H1: 1X (2510mm) H2: 1X (2510mm)</p>	 <p>G</p>	<p>H1: 3x H2: 3x</p>
<p>M5 x 10</p>  <p>D2</p>	<p>H1: 8x H2: 8x</p>				

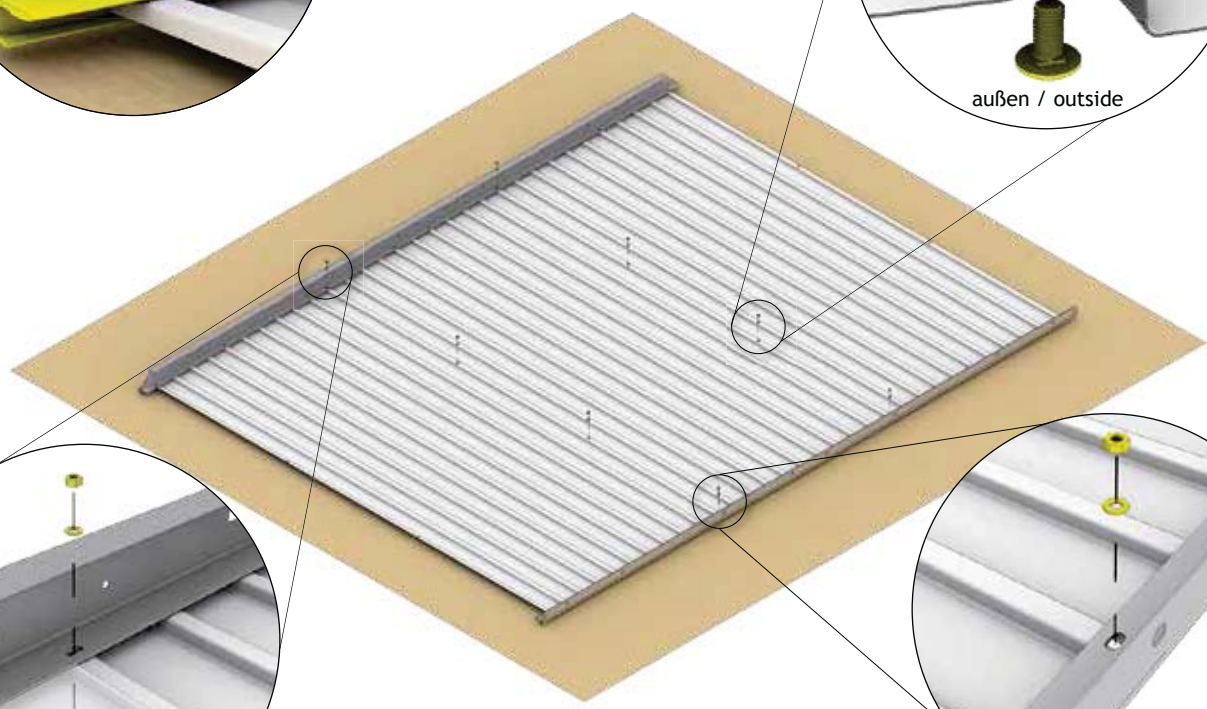
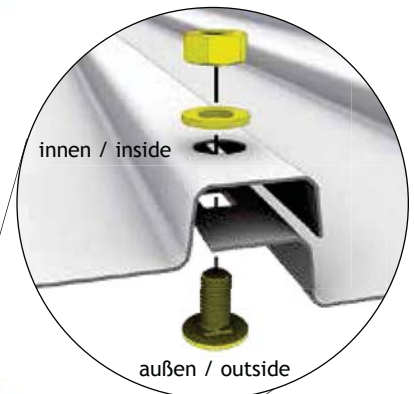
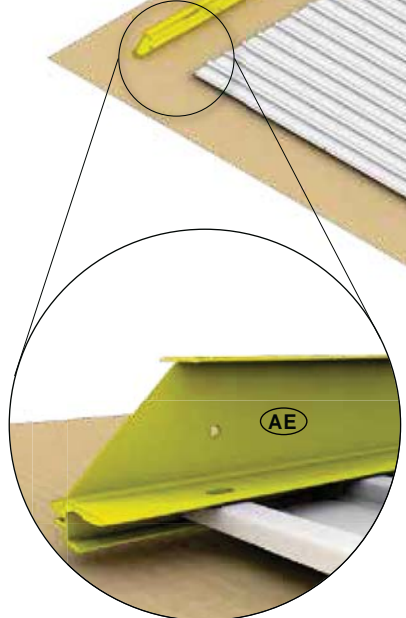
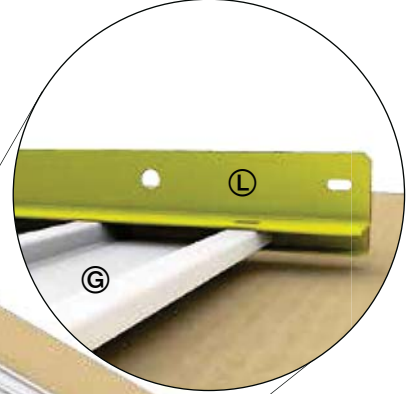
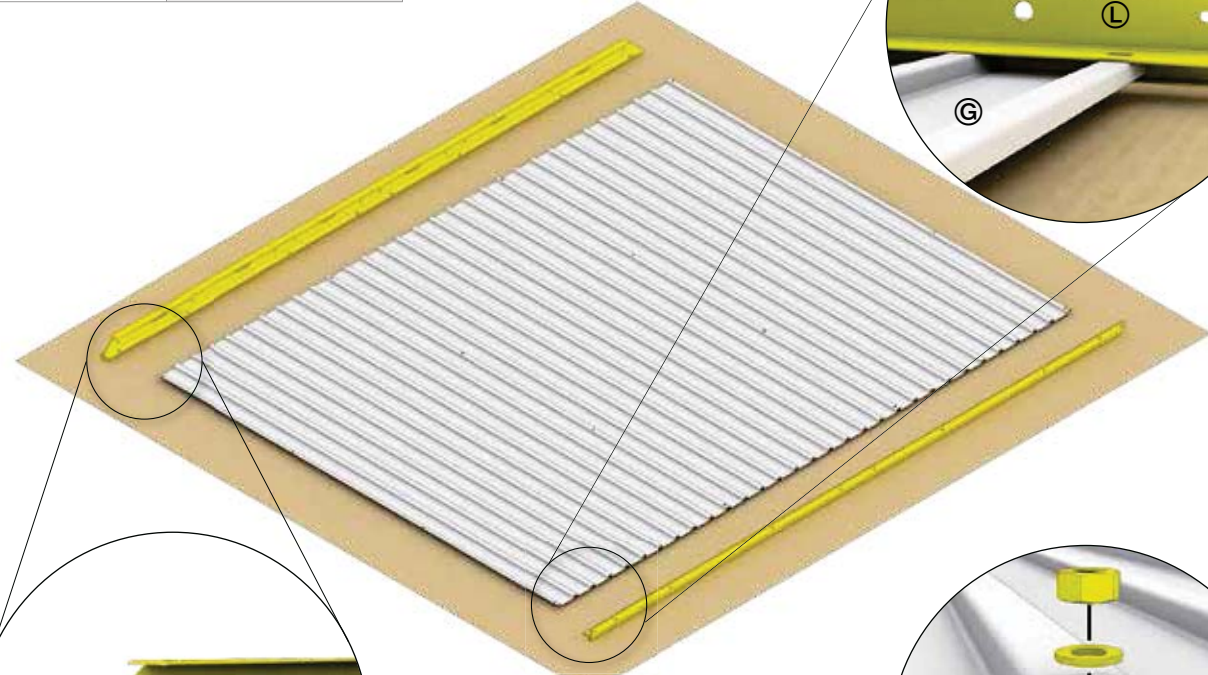



Doppeltüre

Double Door - Deuxième battant de porte - Tweede deurvleugel - Secondo battente - puerta doble



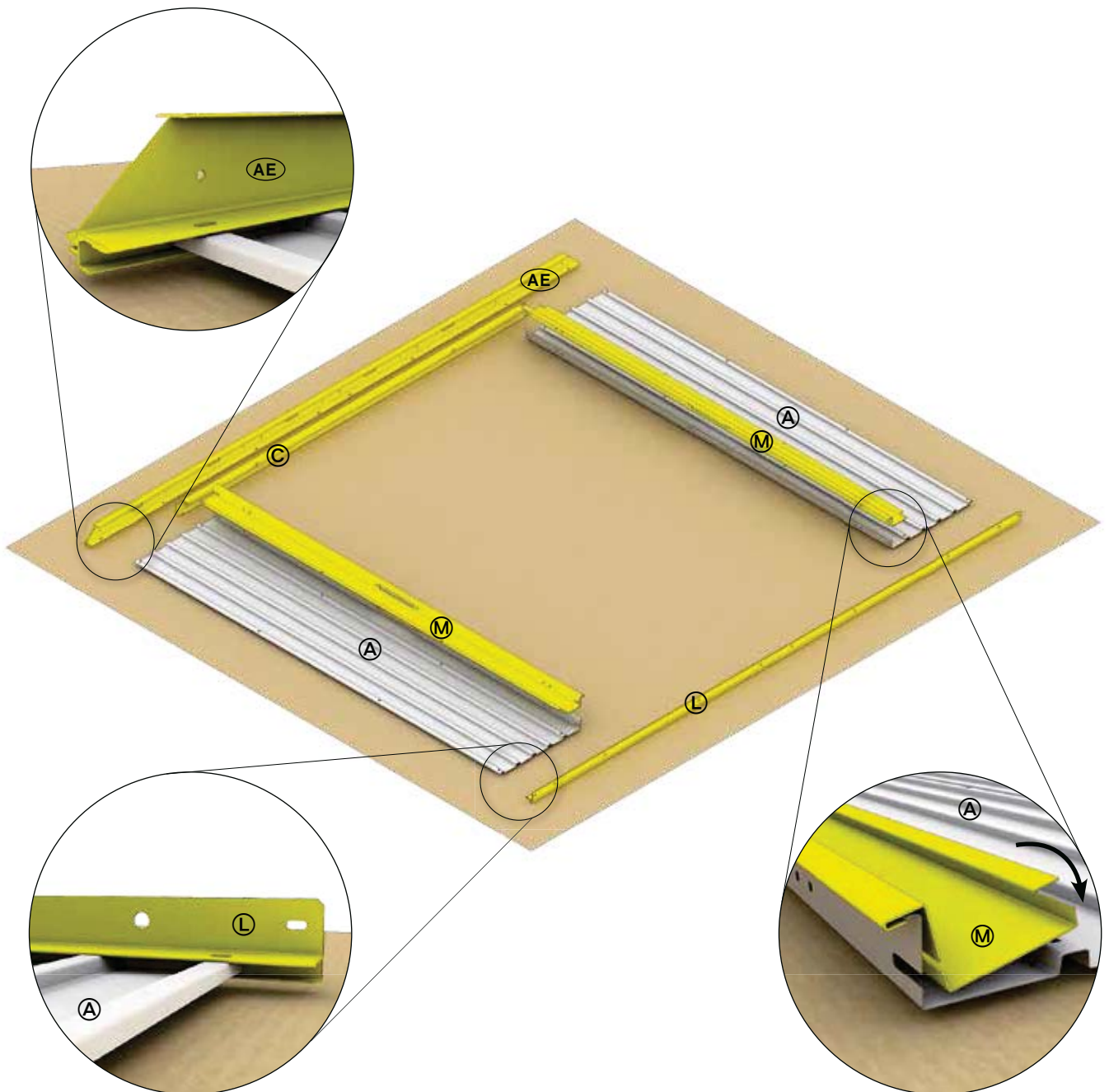



<p>1</p> <p>A</p>	<p>H1: 2x H2: 2x</p>	<p>5</p> <p>AE</p>	<p>H1: 1X (2510mm) H2: 1X (2510mm)</p>	<p>3</p> <p>M</p>	<p>H1: 2x H2: 2x</p>
<p>3</p> <p>L</p>	<p>H1: 1X (2510mm) H2: 1X (2510mm)</p>	<p>1</p> <p>C</p>	<p>H1: 1X (1790mm) H2: 1X (1790mm)</p>		



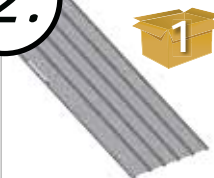

Türwand

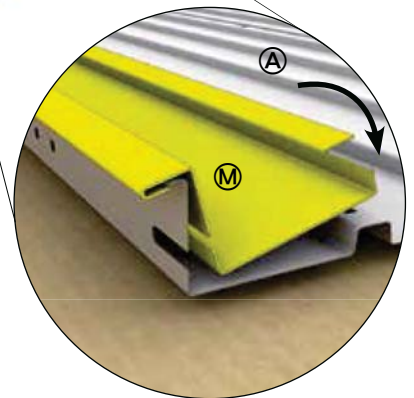
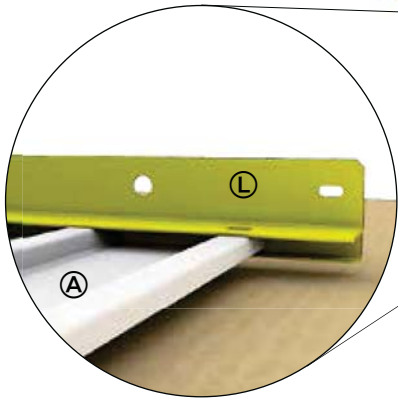
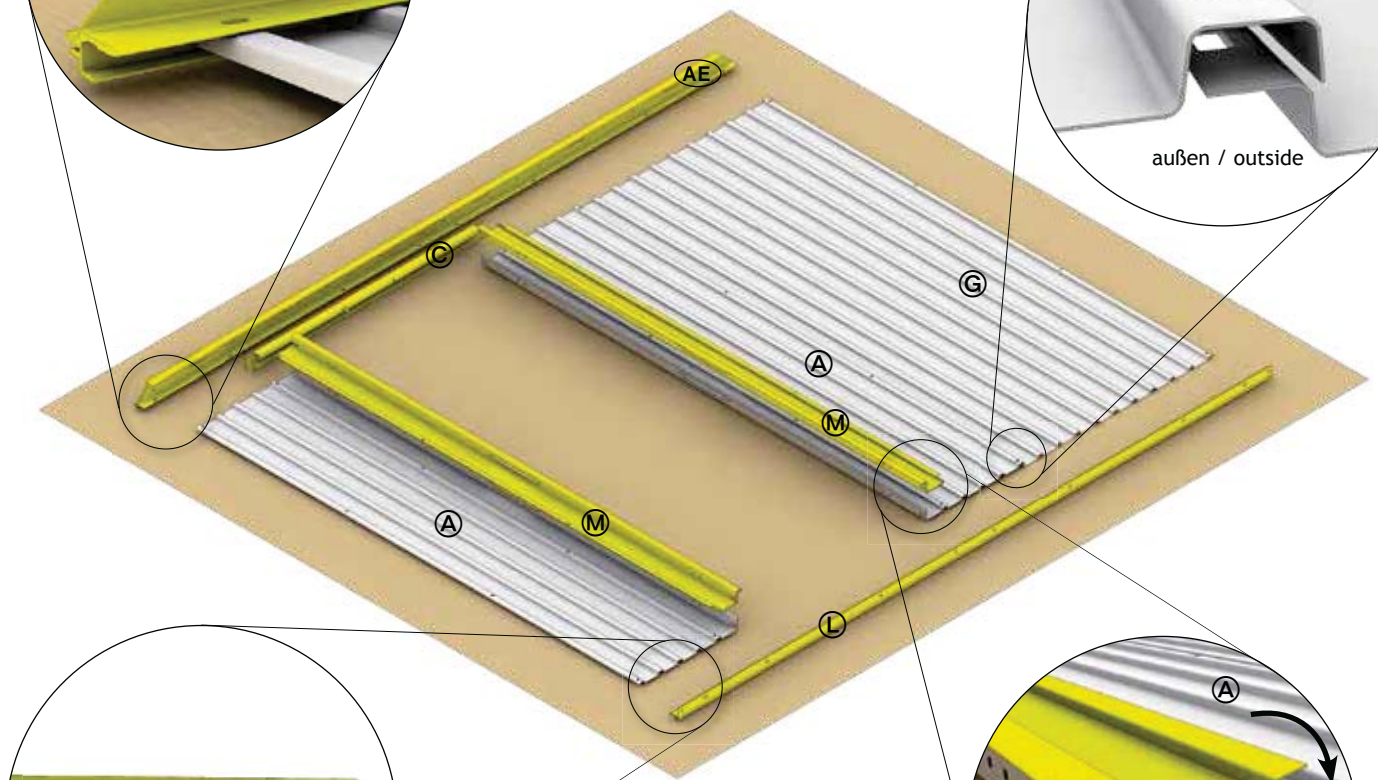
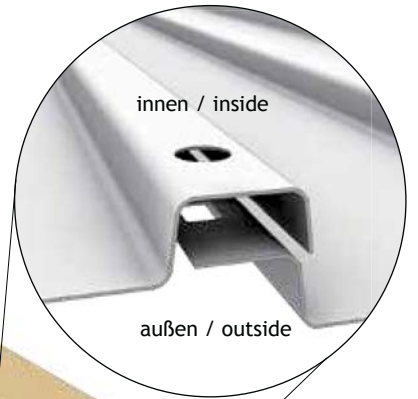
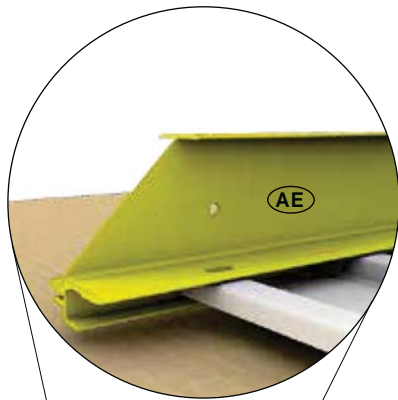

Door wall - Paroi de la porte - Deurwand - panel de puerta - Parete con porta

2.

 <p>1</p> <p>(A)</p>	<p>H1: 2x H2: 2x</p>	 <p>5</p> <p>(AE)</p>	<p>H1: 1x (2510mm) H2: 1x (2510mm)</p>	 <p>3</p> <p>(M)</p>	<p>H1: 2x H2: 2x</p>
 <p>3</p> <p>(L)</p>	<p>H1: 1x (2510mm) H2: 1x (2510mm)</p>	 <p>1</p> <p>(C)</p>	<p>H1: 1x (990mm) H2: 1x (990mm)</p>	 <p>1</p> <p>(G)</p>	<p>H1: 1x H2: 1x</p>



<p>M5 x 10</p>  <p>(D2)</p>	<p>H1: 12x H2: 12x</p>	<p>M5 x 18</p>  <p>(D2)</p>	<p>H1: 2x H2: 2x</p>
--	----------------------------	--	--------------------------



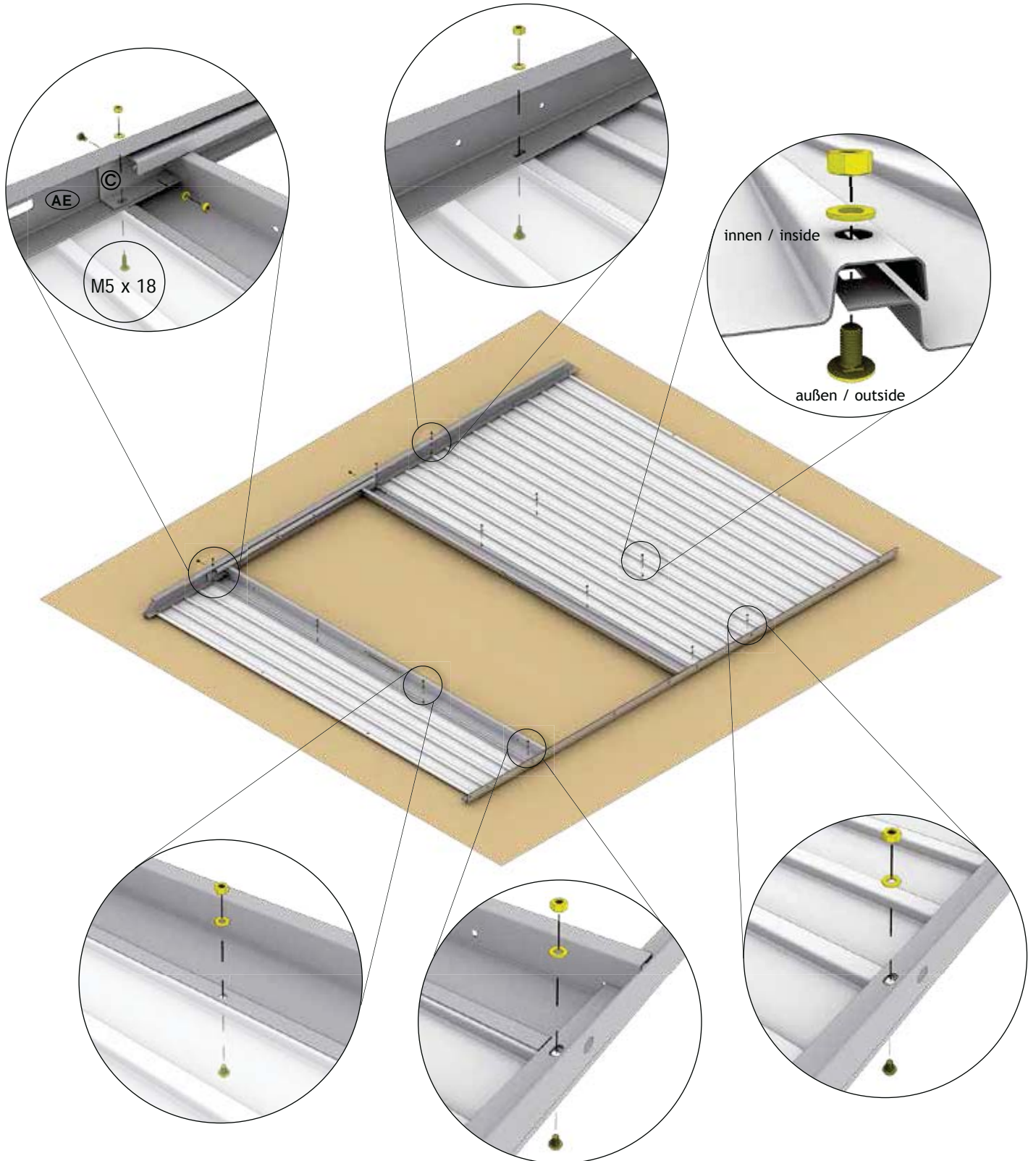

<p>Doppeltüre <i>Double Door - Deuxième battant de porte - Tweede deurvleugel - Secondo battente - puerta doble</i></p>	<p>M5 x 10</p>  <p>(D2)</p>	<p>H1: 8x H2: 8x</p>	<p>M5 x 18</p>  <p>(D2)</p>	<p>H1: 2x H2: 2x</p>
---	--	--------------------------	--	--------------------------



Seitenwand

Side wall - Paroi latérale - Zijwand - panel lateral - Parete laterale

3.

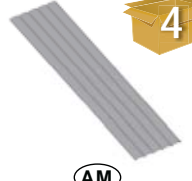
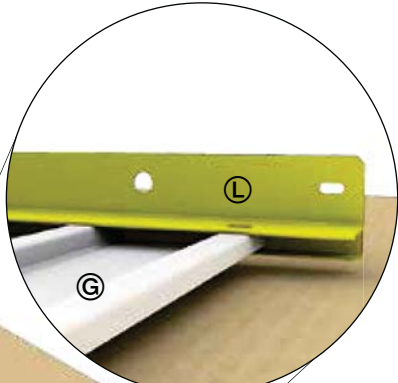
 <p>5</p> <p>AE</p>	<p>H1: 2X (1310 mm) H2: 2X (1710 mm)</p>	 <p>3</p> <p>L</p>	<p>H1: 2X (1310 mm) H2: 2X (1710 mm)</p>	 <p>2</p> <p>G</p>	<p>H1: 2x H2: 4x</p>
<p>M5 x 10</p>  <p>D2</p>	<p>H1: 8x H2: 8x</p>	 <p>4</p> <p>AM</p>	<p>H1: 2x</p>		

2x

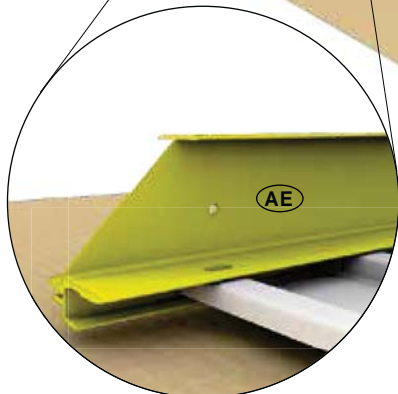
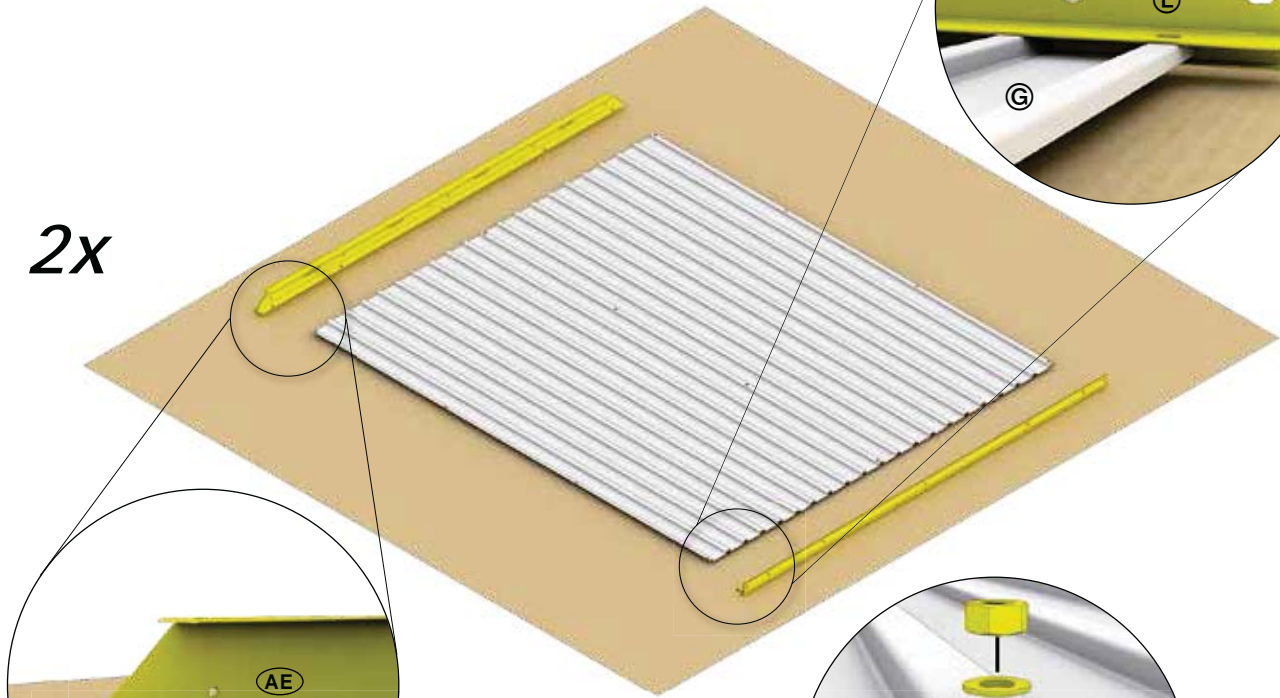

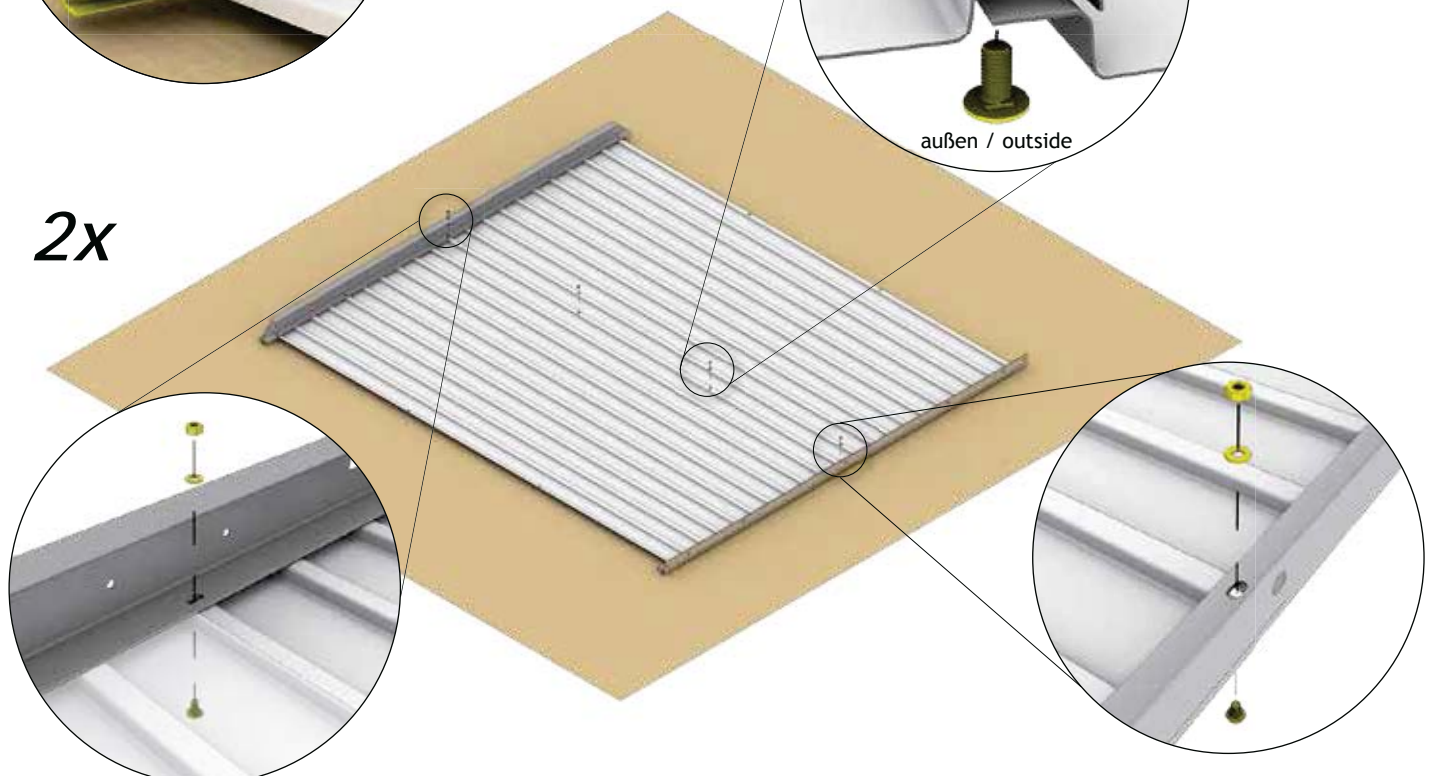

2x





Bodenrahmen

Floor Frame - Cadre de sol - Telaio perimetrale - Bodemframe - marco de suelo

 <p>ZB</p>	H1: 2X (1240 mm) 2X (2440 mm)	 <p>ZC</p>	H1: 4X H2: 4X
	H2: 2X (1640 mm) 2X (2440 mm)		

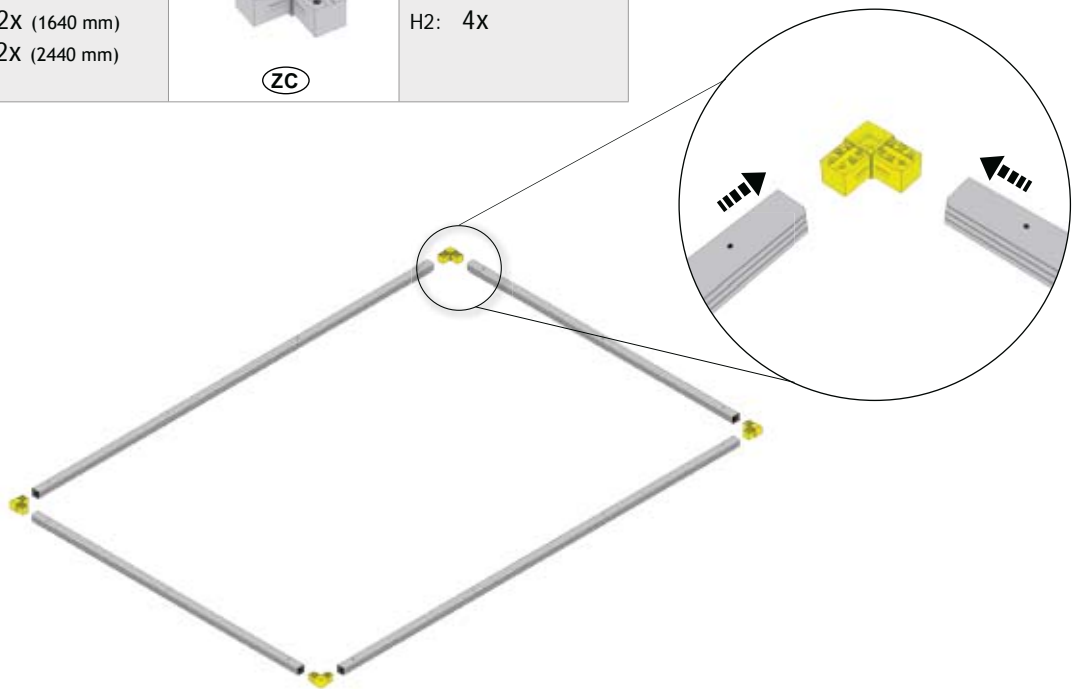



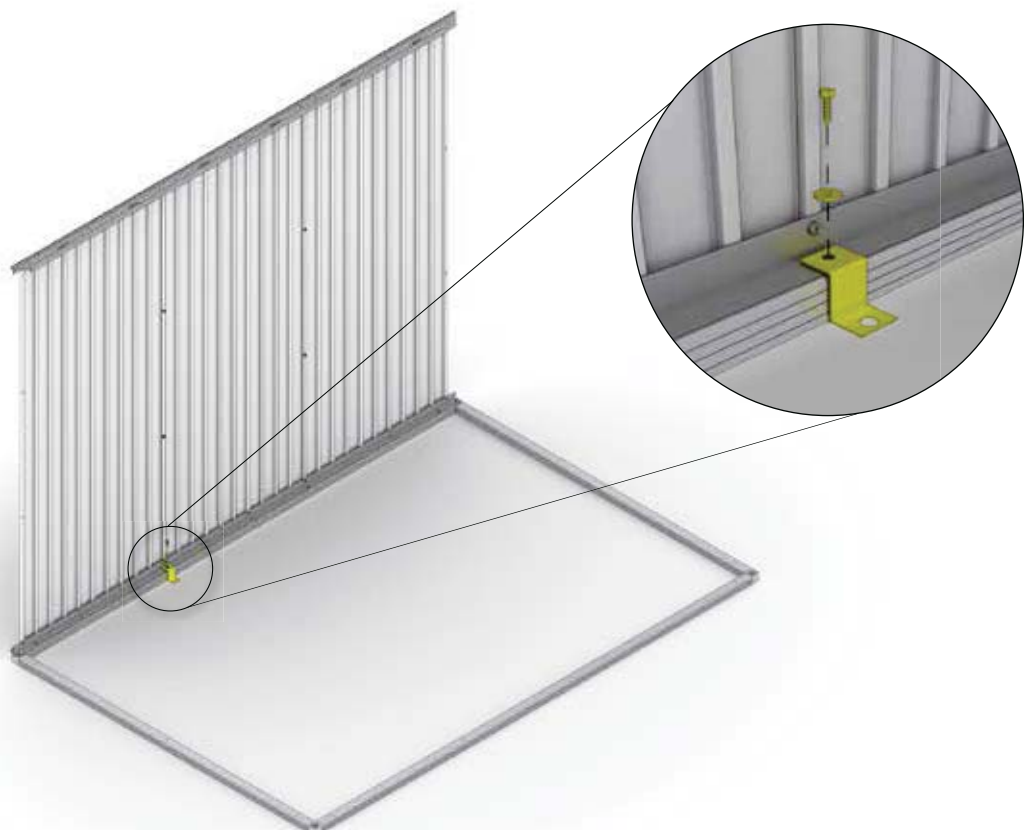

 <p>ZD</p>	H1: 1X H2: 1X	6,3 x 22  <p>ZF</p>	H1: 1X H2: 1X





Bodenrahmen

Floor Frame - Cadre de sol - Telaio perimetrale - Bodemframe - marco de suelo

 (AF)	 H1: 4x H2: 4x	 (ZF)	H1: 6x H2: 8x	6,3 x 22  (ZF)	H1: 12x H2: 12x
M5 x 10  (D2)	H1: 12x H2: 12x	 (AD)	 H1: 2x H2: 2x		

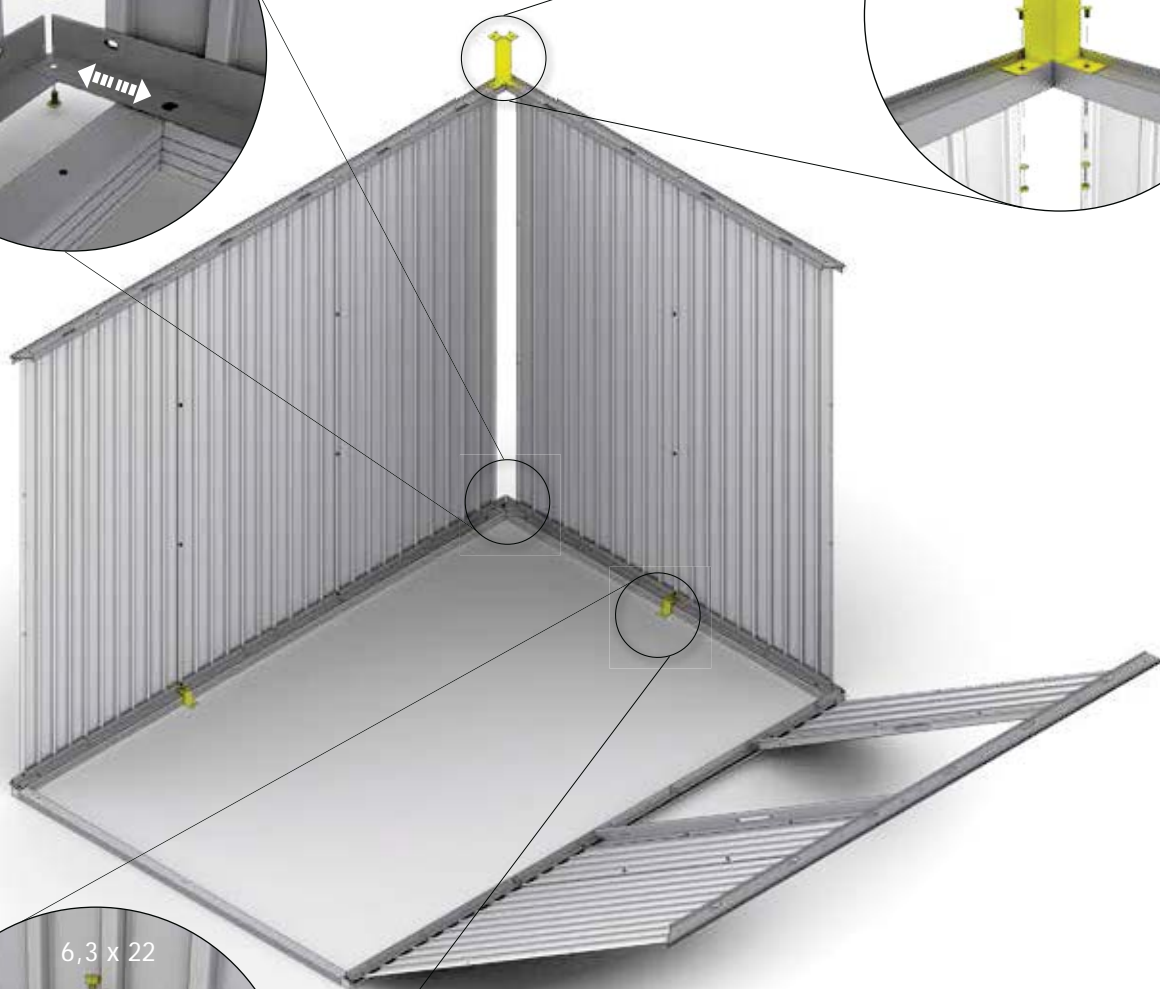
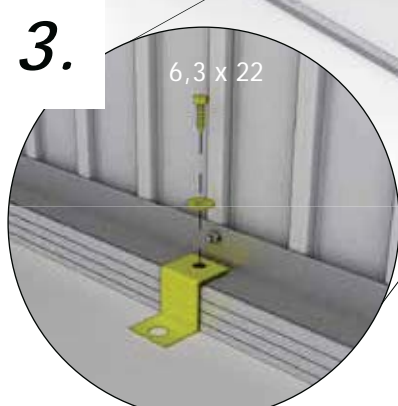
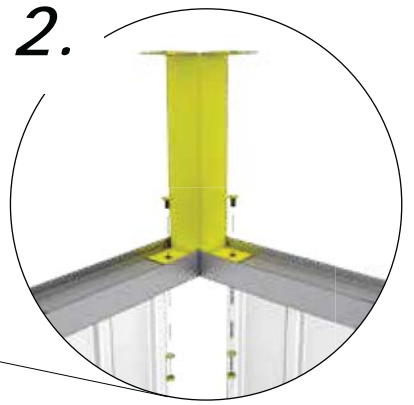
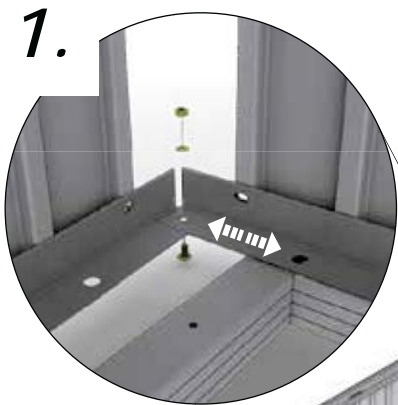

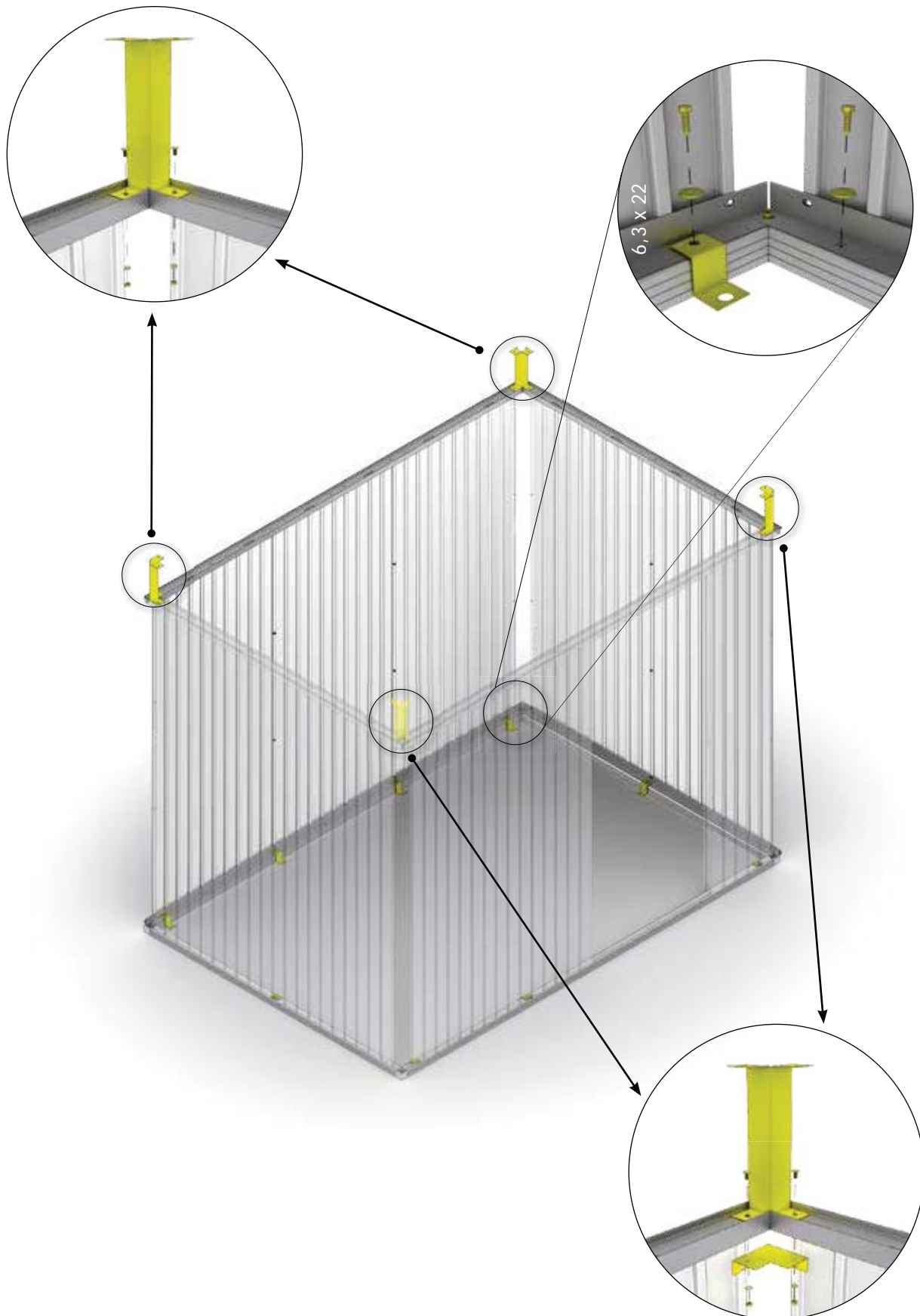

4.

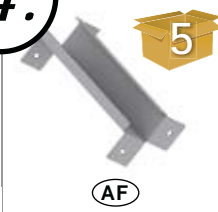

H1: 4x
H2: 4x



H1: 2x
H2: 2x



M5 x 10

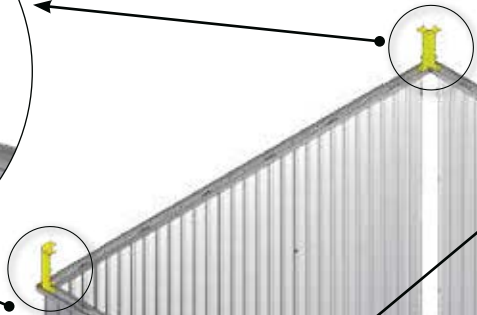
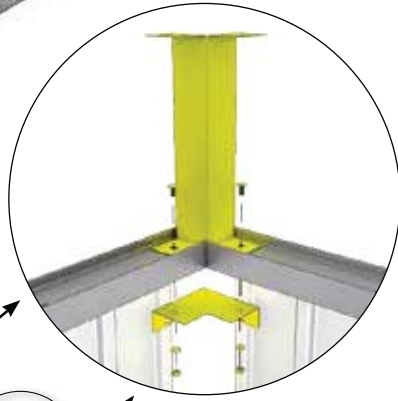
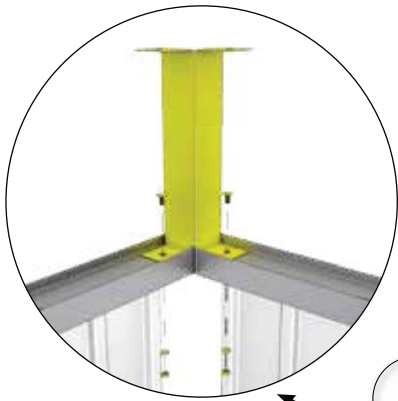
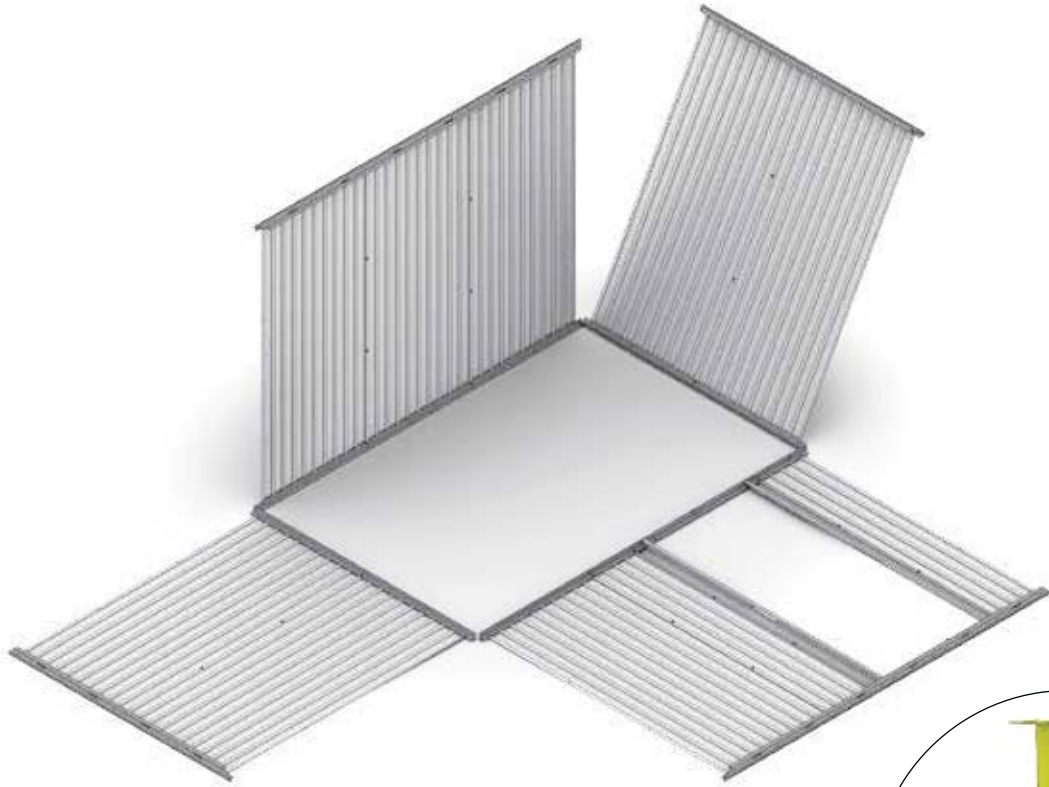

H1: 12x
H2: 12x



5.

 AG	 H1: 4x H2: 6x	M5 x 10  D2	H1: 8x H2: 12x
---	---	--	-------------------

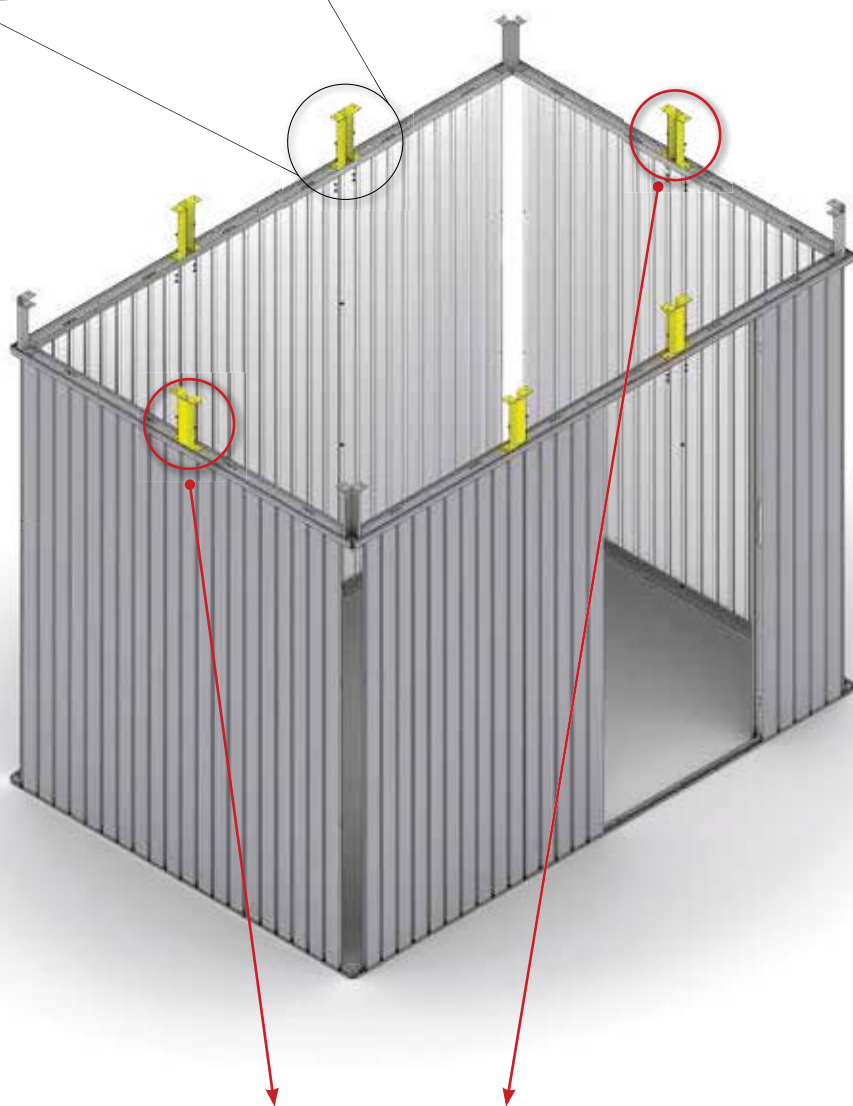

entfällt bei Größe H1
GB does not apply to size H1
FR s'applique pas à la taille H1
NL van toepassing op maat H1
ES se aplica a tamaño H1
IT si applica alla taglia H1

6.

5

H1: 2X (1310 mm)
2X (2510 mm)
H2: 2X (1710 mm)
2X (2510 mm)

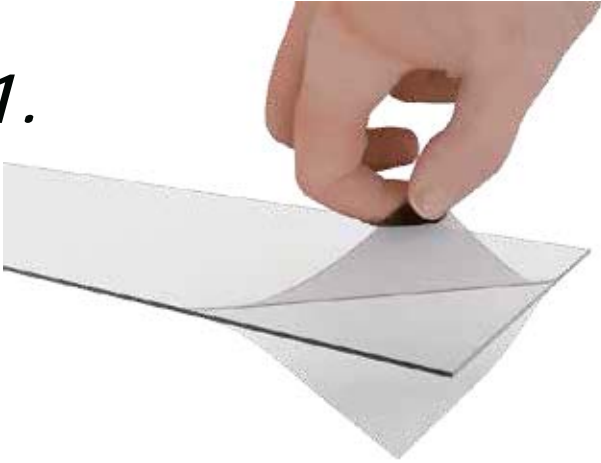

AH

1.

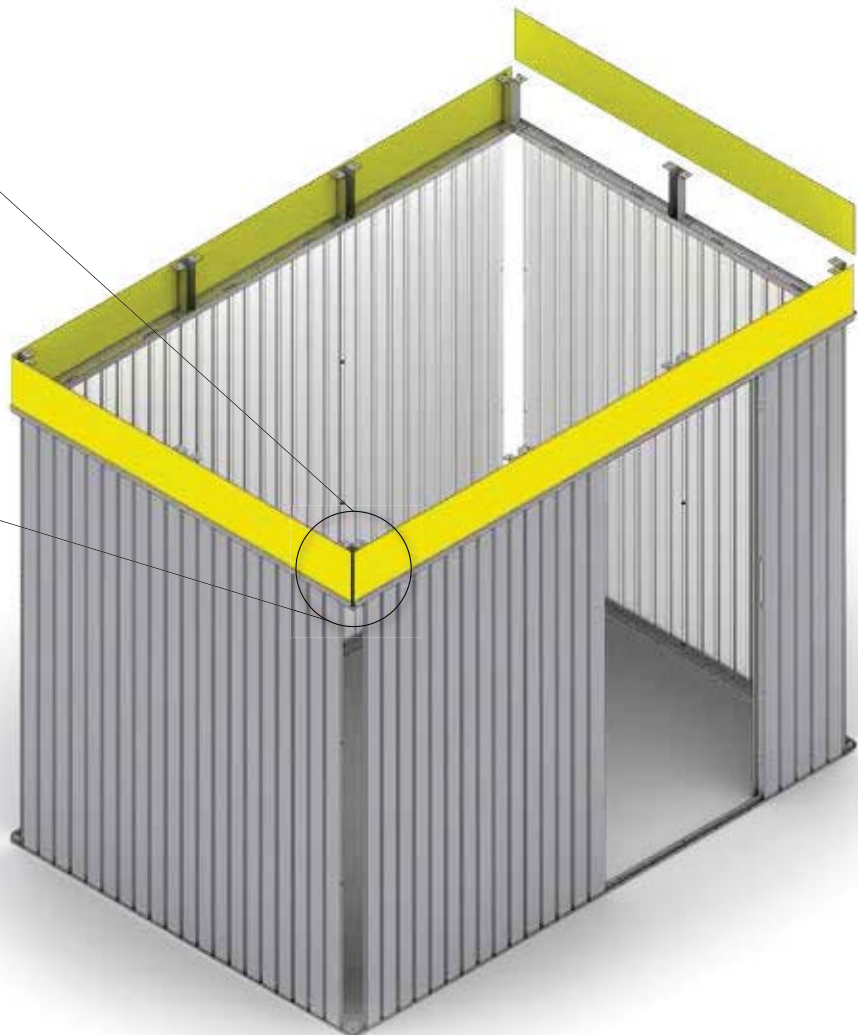
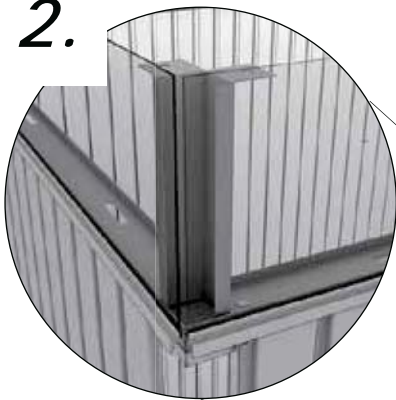

2.





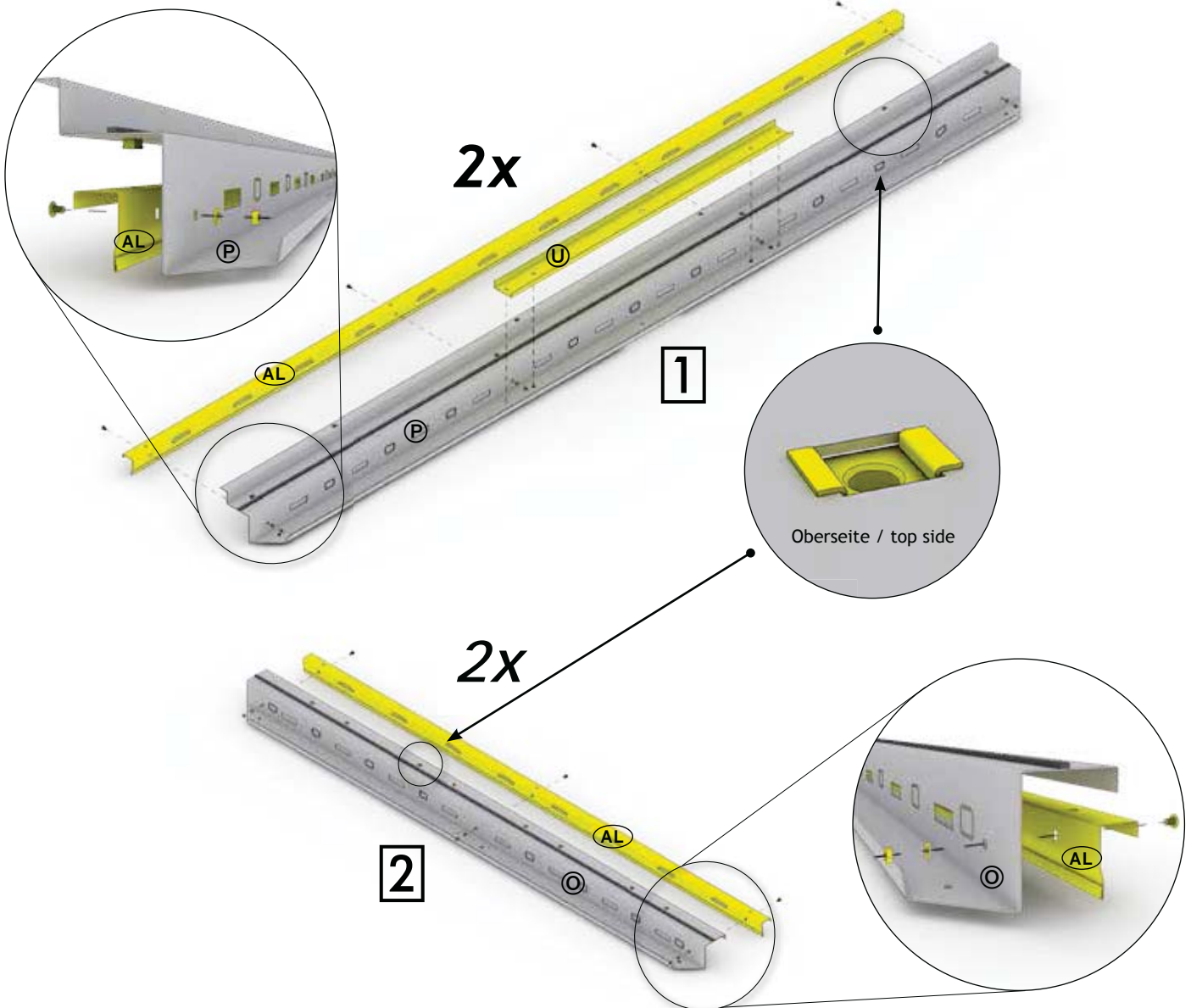
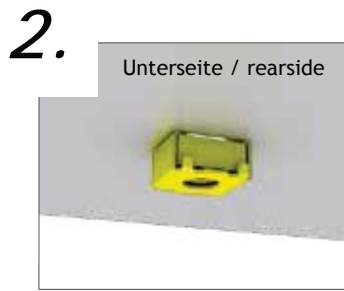

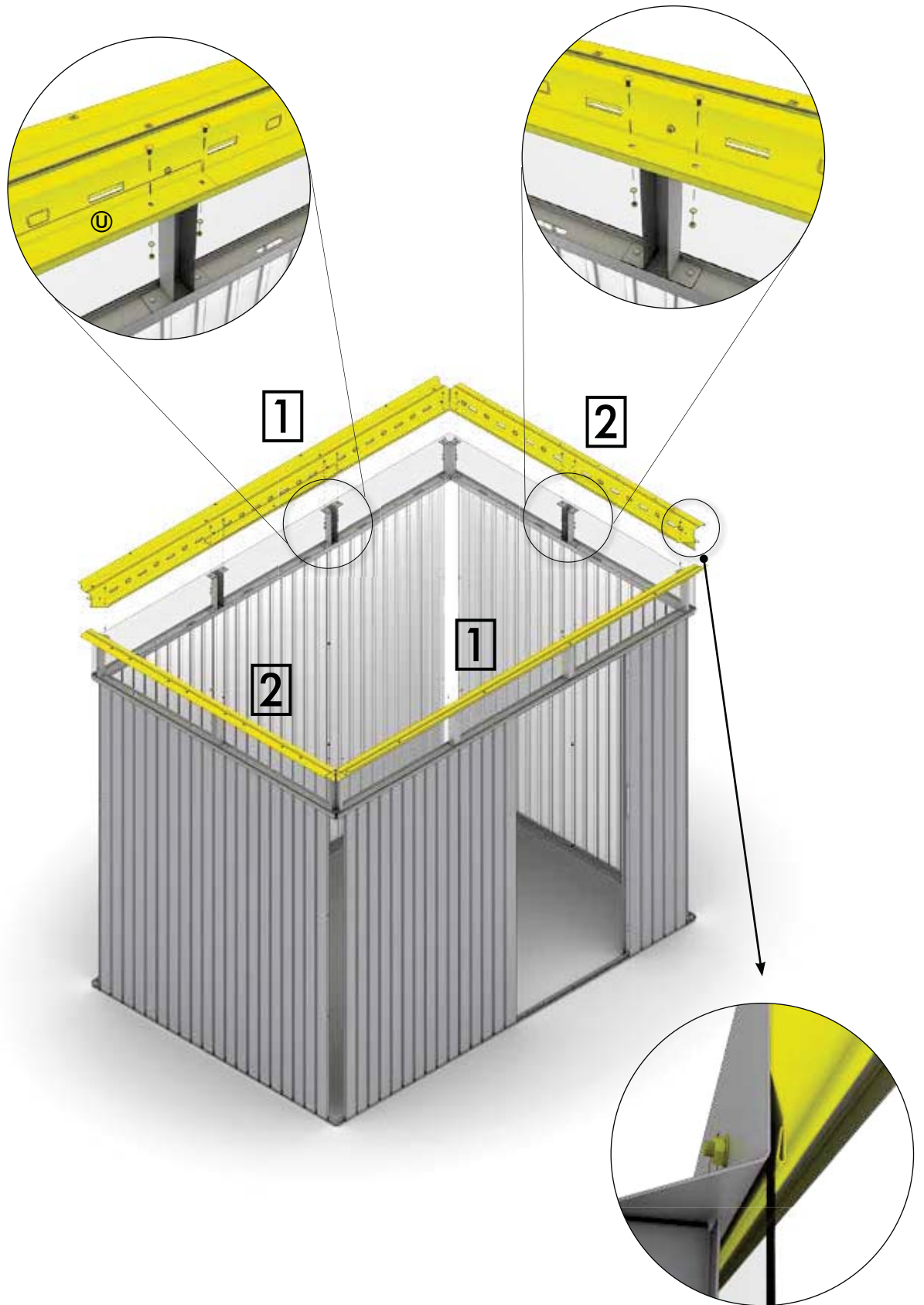
<p>7.</p>  <p>ⓐ</p>	<p>3</p> <p>H1: 2X (1320 mm) H2: 2X (1720 mm)</p>	<p>3</p>  <p>ⓑ</p>	<p>H1: 2X (2520 mm) H2: 2X (2520 mm)</p>	<p>3</p>  <p>ⓐ</p>	<p>H1: 2X (918 mm) H2: 2X (918 mm)</p>
 <p>Ⓐ</p>	<p>5</p> <p>H1: 2X (1320 mm) 2X (2520 mm) H2: 2X (1720 mm) 2X (2520 mm)</p>	 <p>Ⓓ</p>	<p>H1: 28x H2: 32x</p>	<p>M5 x 10</p>  <p>Ⓓ</p>	<p>H1: 30x H2: 34x</p>





8.

 <p>Ⓢ</p>	<p>H1: 1X (1300 mm) H2: 1X (1700 mm)</p>	 <p>Ⓣ</p>	<p>H1: 1X (1300 mm) H2: 1X (1700 mm)</p>	<p>M8 x 16</p>  <p>Ⓣ</p>	<p>H1: 6X H2: 6X</p>
<p>M8 x 90</p>  <p>Ⓣ</p>	<p>H1: 2X H2: 2X</p>				

1.

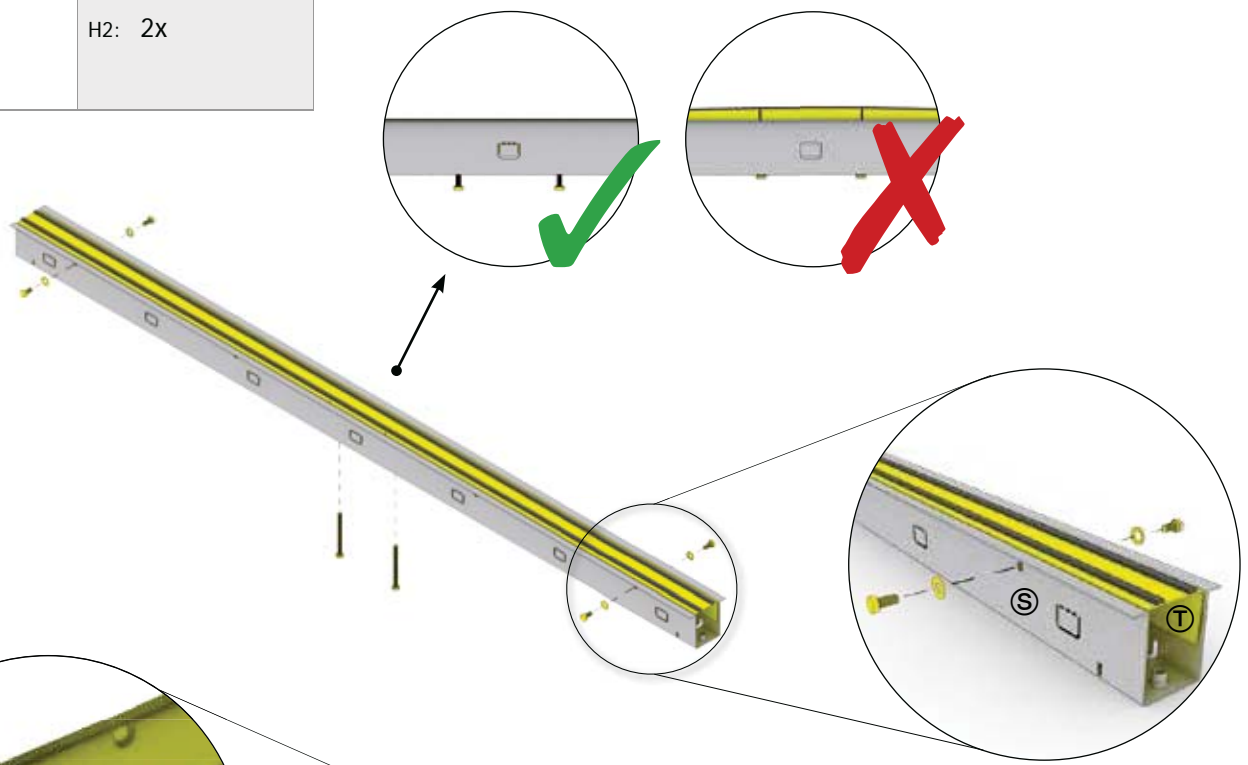

2.

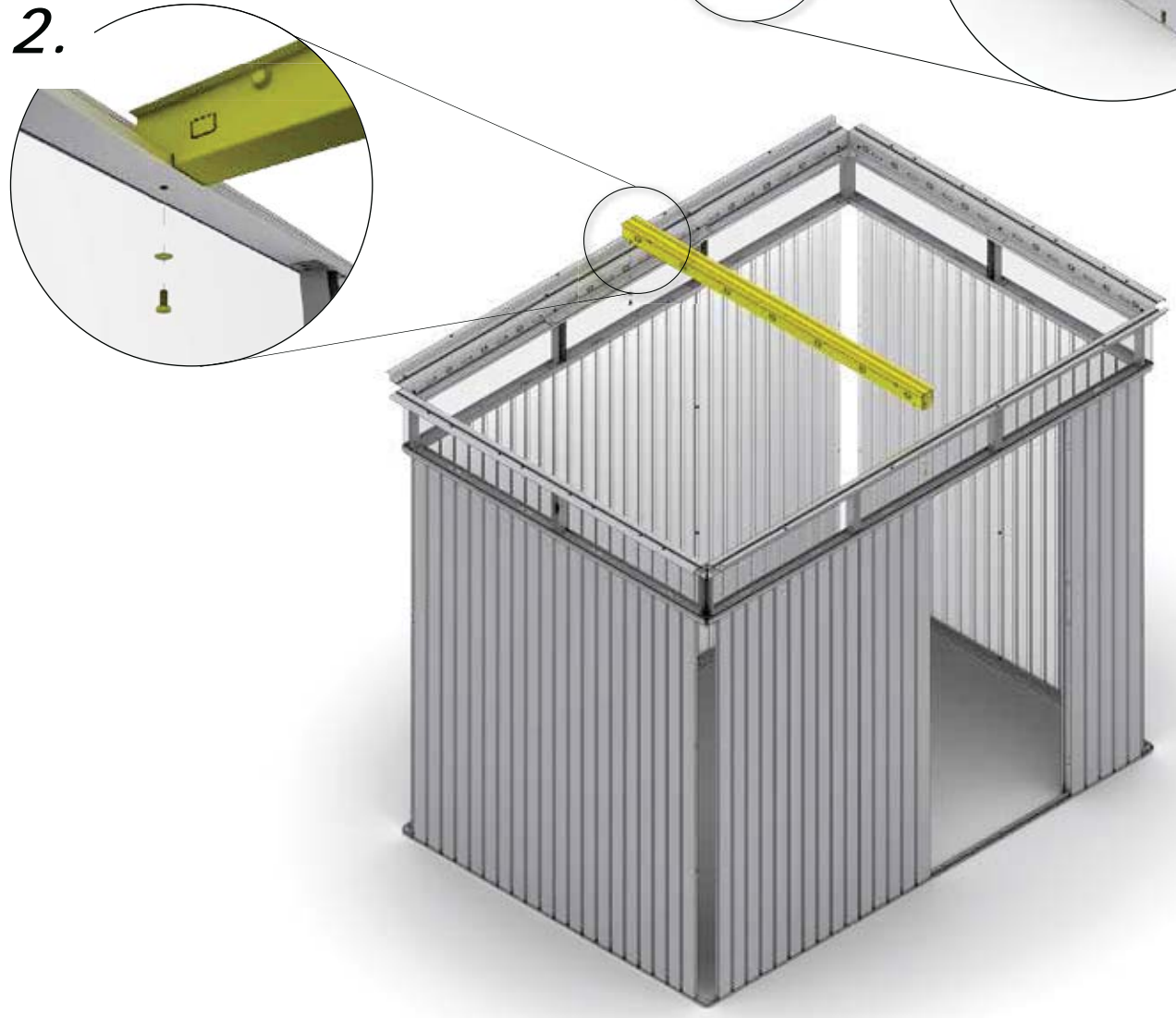

<p>9.</p>  <p>H1: 1x H2: 1x</p>	 <p>H1: 6x H2: 6x</p> <p>(D2)</p>	<p>M5 x 16</p>  <p>H1: 6x H2: 6x</p> <p>(D2)</p>
--	--	--

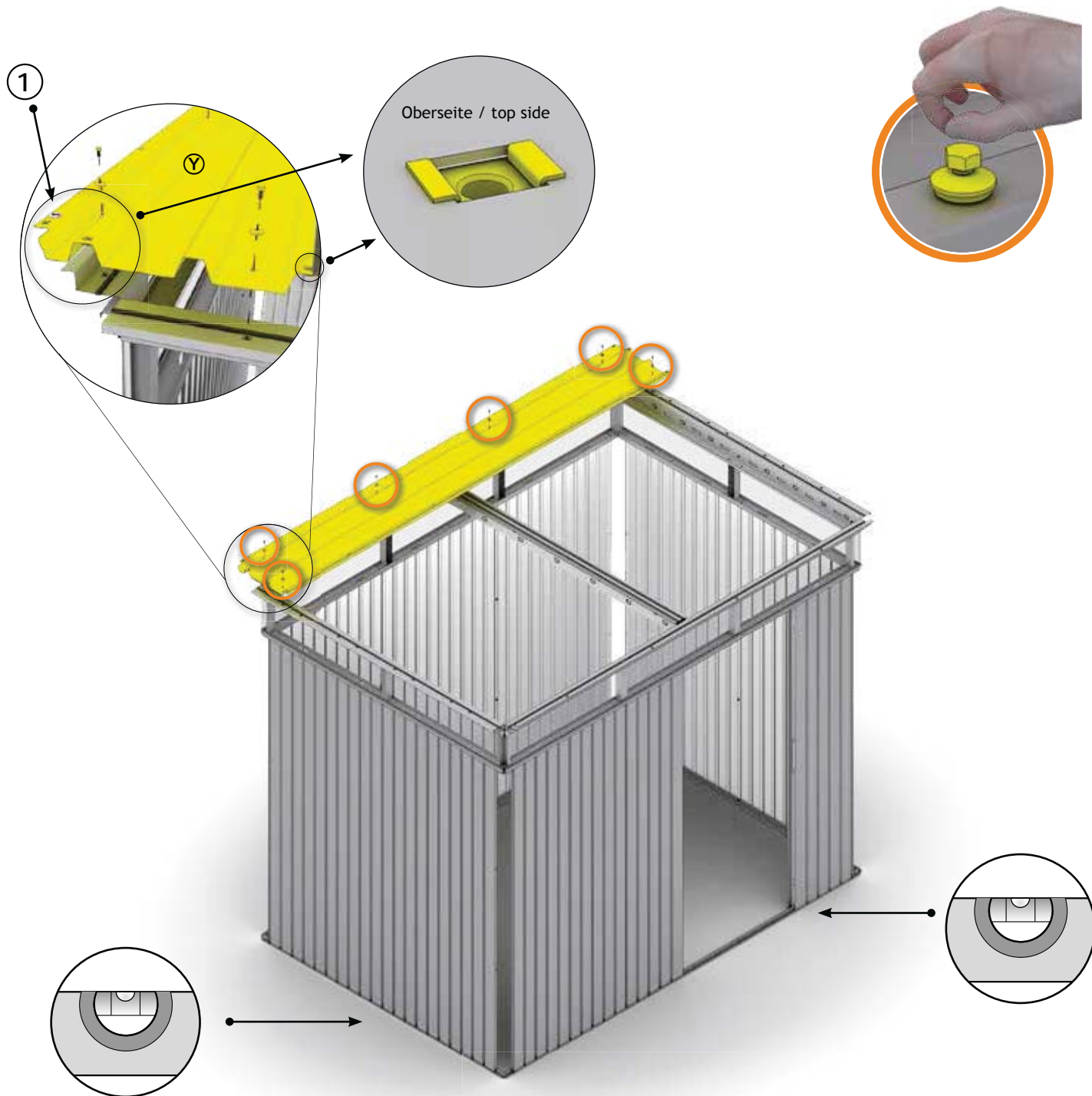



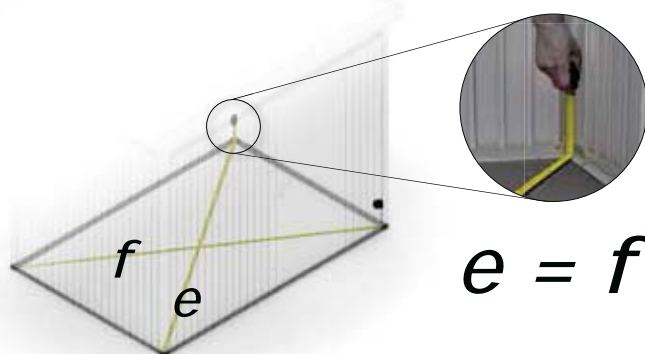

Rechtwinkelig einrichten

- (GB) rectangular adjusted
- (FR) ajuster en forme rectangulaire
- (NL) rechthoekig instellen
- (ES) ajustar en forma rectangular
- (IT) Mettere in squadra



10.

 <p>4</p> <p>⊗</p>	<p>H1: 2x H2: 3x</p>	 <p>ⓓ2</p>	<p>H1: 4x H2: 6x</p>
<p>M5 x 16</p>  <p>ⓓ2</p>	<p>H1: 8x H2: 12x</p>	<p>M5 x 16</p>  <p>ⓓ2</p>	<p>H1: 8x H2: 12x</p>



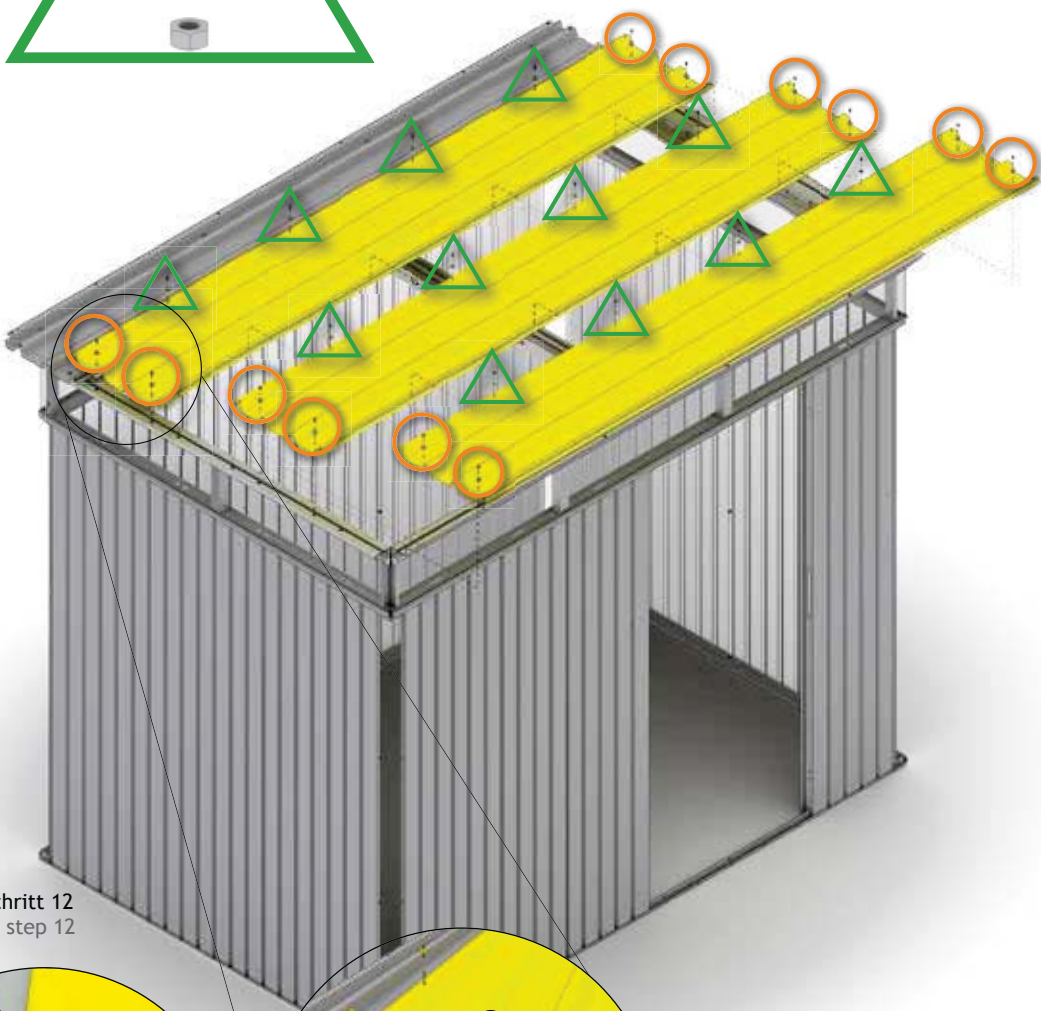
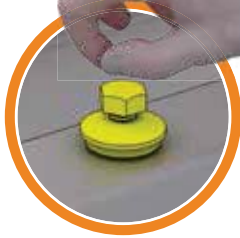
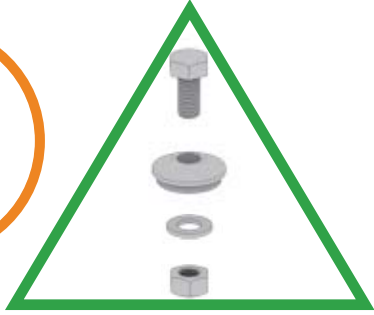

Festziehen
 ⒸB tighten
 ⒻR serrez fort
 ⒹL vastdraaien
 ⒺS apriete
 ⒾT Serrare a fondo

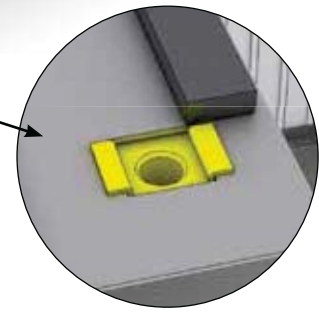
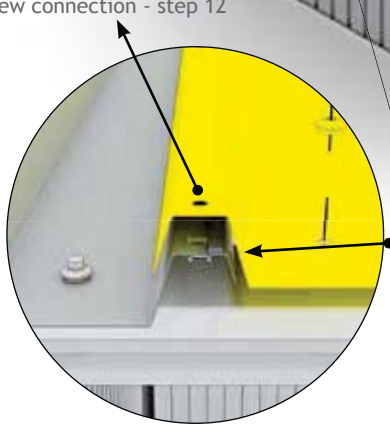

Verschraubung - Schritt 12
 screw connection - step 12



11.





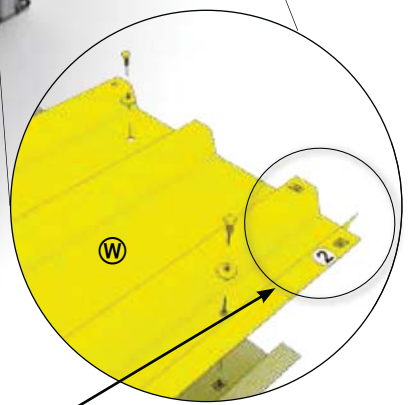
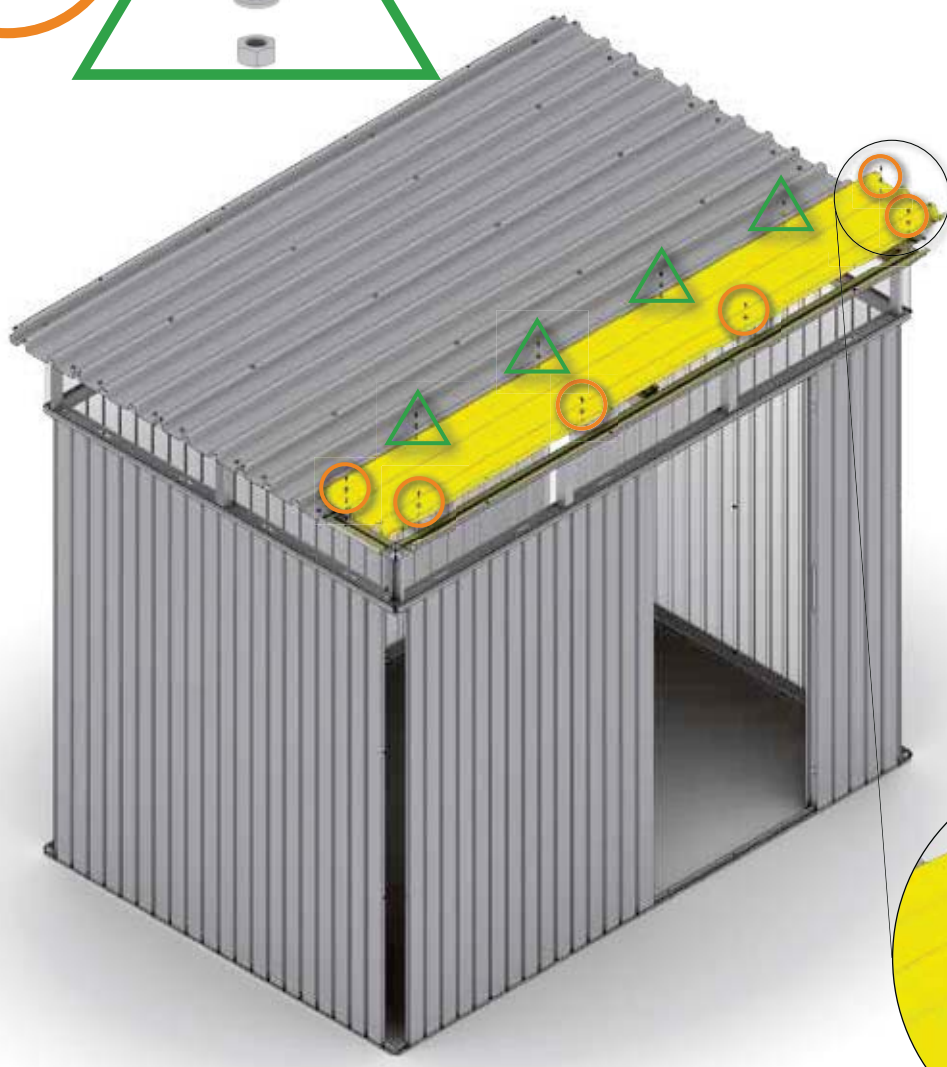

	 <p>H1: 1x H2: 1x</p>	 <p>H1: 4x H2: 4x</p>	
<p>M5 x 16</p>  <p>(D2)</p>	<p>H1: 6x H2: 6x</p>	<p>M5 x 16</p>  <p>(D2)</p>	<p>H1: 4x H2: 4x</p>

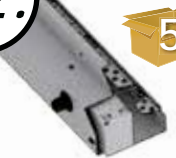

Festziehen
 (GB) tighten
 (FR) serrez fort
 (NL) vastdraaien
 (ES) apriete
 (IT) Serrare a fondo



12.

 <p>(AB)</p>	<p>5</p> <p>H1: 1X (1480 mm) H2: 1X (1880 mm)</p>	 <p>(AA)</p>	<p>5</p> <p>H1: 1X (1480 mm) H2: 1X (1880 mm)</p>	 <p>(Z)</p>	<p>5</p> <p>H1: 2X (2655 mm) H2: 2X (2655 mm)</p>
<p>M5 x 16</p>  <p>(D2)</p>	<p>H1: 18x H2: 20x</p>	<p>4,8 x 13</p>  <p>(D2)</p>	<p>H1: 14x H2: 14x</p>	 <p>(D2)</p>	<p>H1: 4x H2: 4x</p>

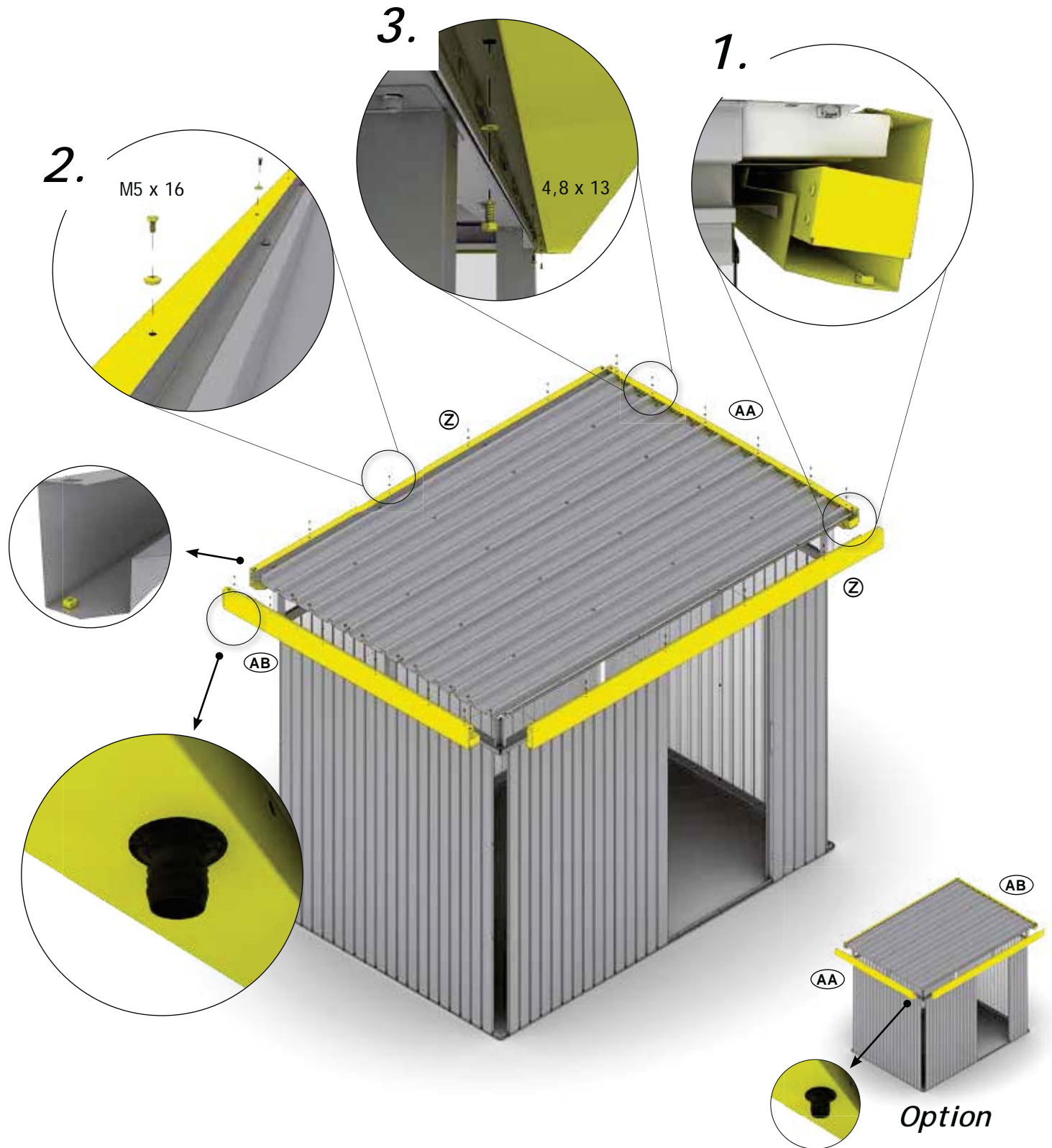

13.



AJ

H1: 4x
H2: 4x

M5 x 16



D2

H1: 8x
H2: 8x

M5 x 16



D2

H1: 8x
H2: 8x

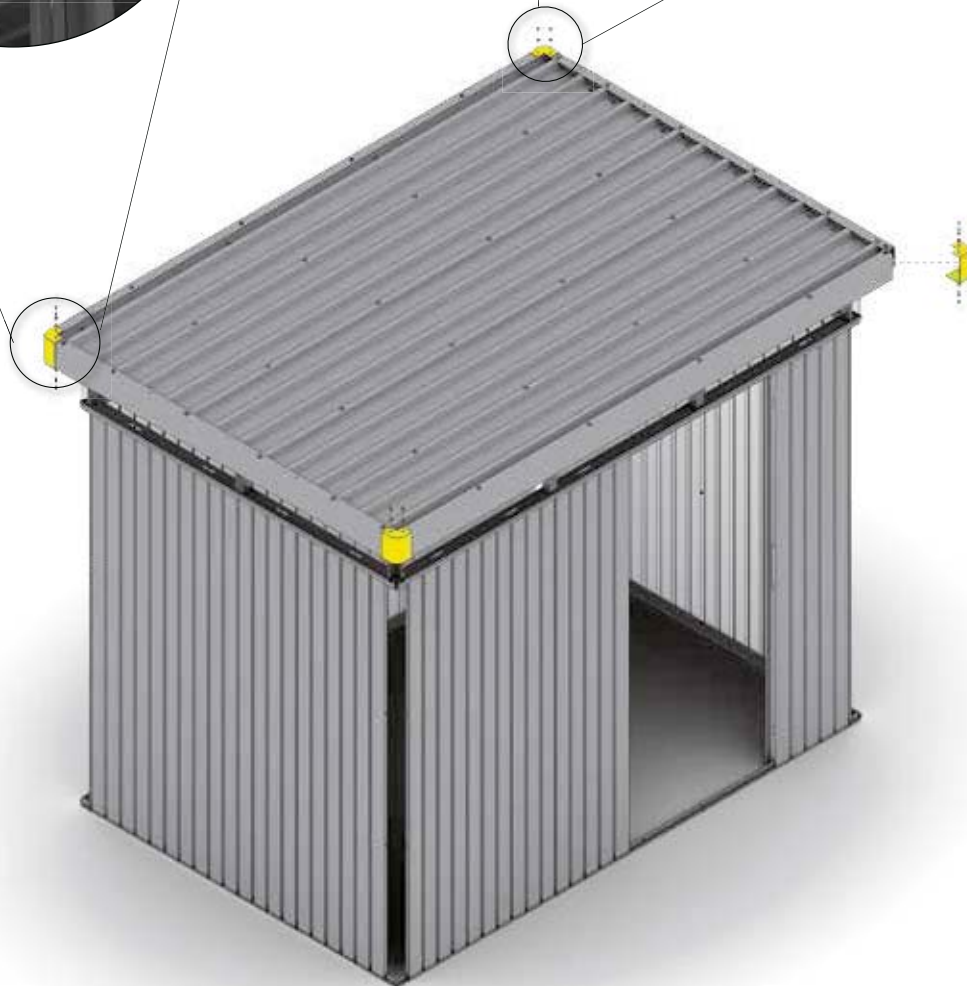
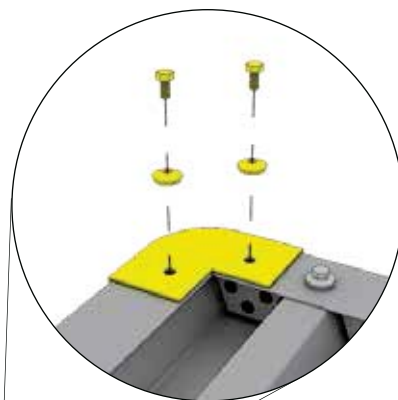
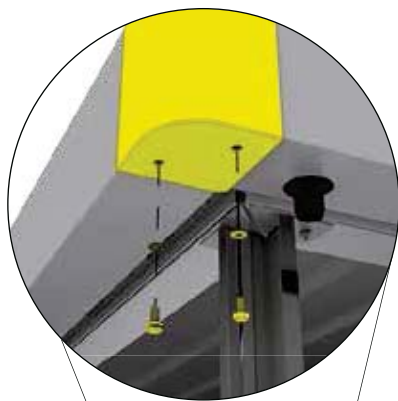

14.

5

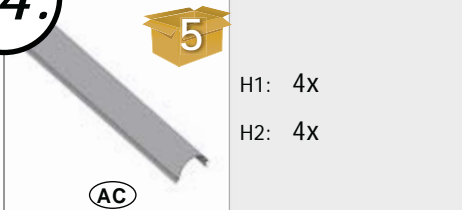

H1: 4x
H2: 4x



H1: 4x
H2: 4x



H1: 4x
H2: 4x

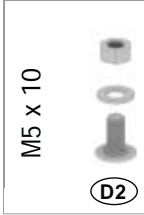

H1: 28x
H2: 28x

4.

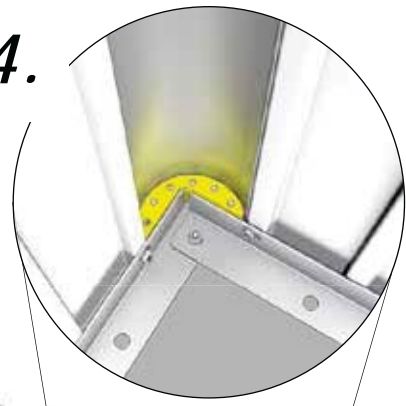

1.

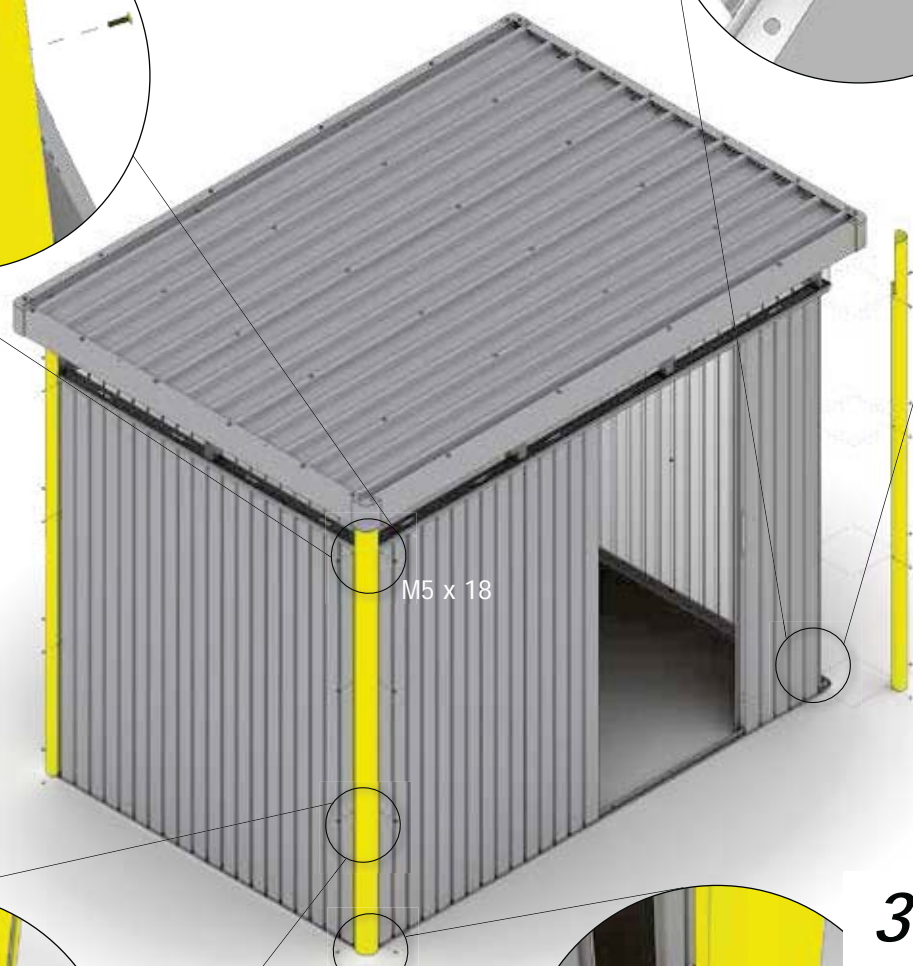
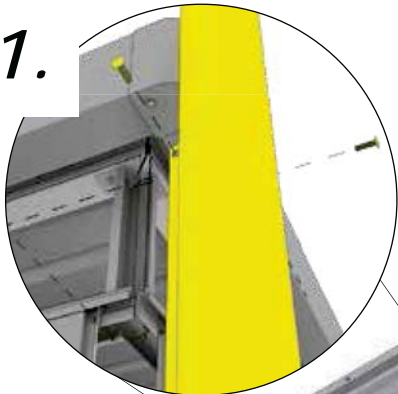

2.

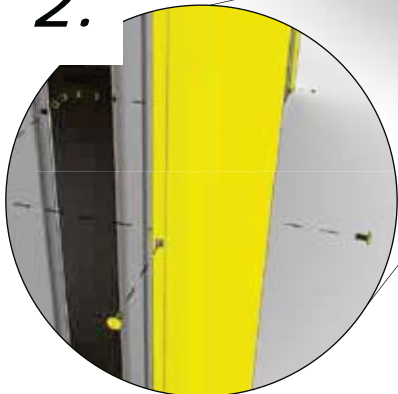

3.

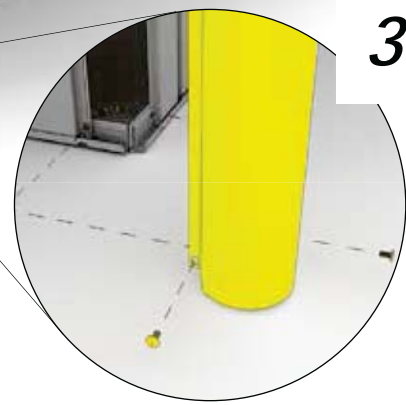

15.

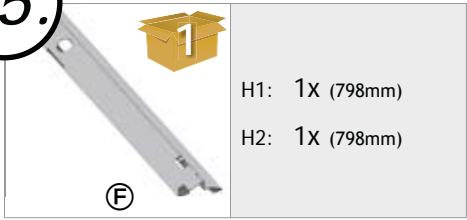

Doppeltüre

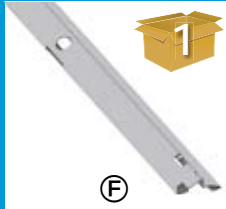

Double Door - Deuxième battant de porte -
Tweede deurvleugel - Secondo battente -
puerta doble





Bodenrahmen

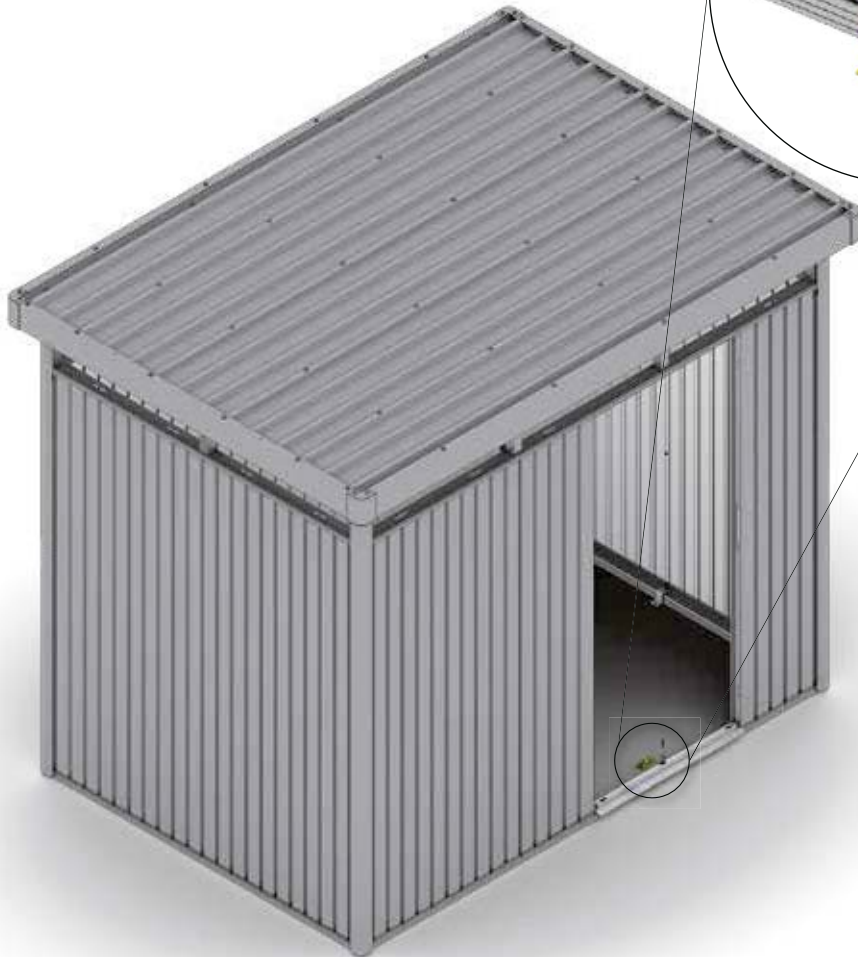
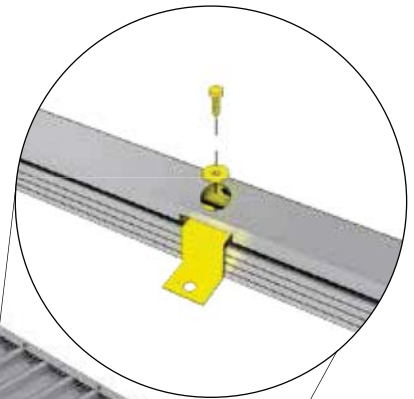

Floor Frame - Cadre de sol - Telaio perimetrale - Bodemframe - marco de suelo

 ZD	H1: 1x	6,3 x 22	 ZF	H1: 1x
	H2: 1x			H2: 1x





Doppeltüre

Double Door - Deuxième battant de porte - Tweede deurvleugel - Secondo battente - puerta doble

 ZD	H1: 2x	6,3 x 22	 ZF	H1: 2x
	H2: 2x			H2: 2x



16.

	H1: 2x
	H2: 2x

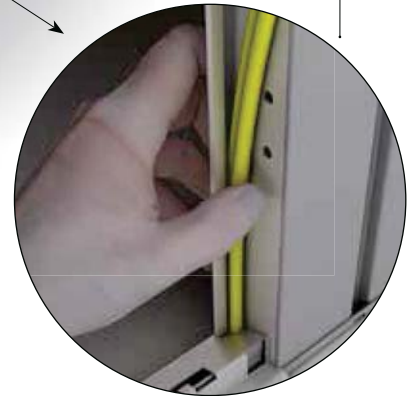
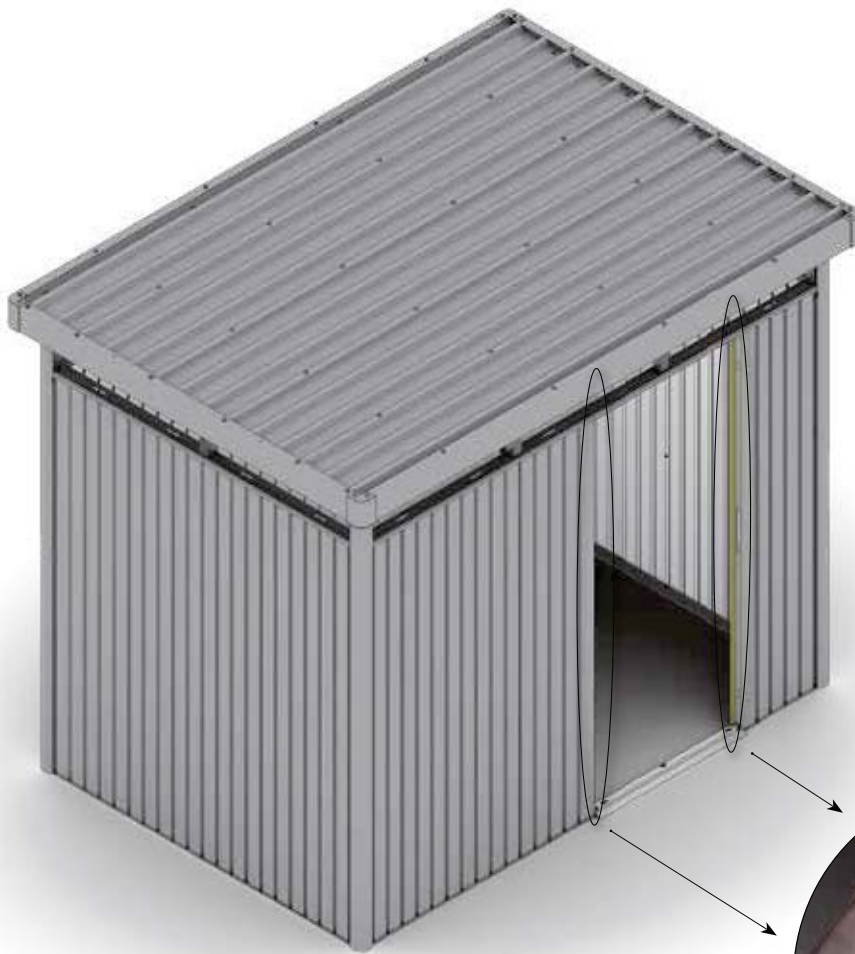

optionales Zubehör - Accessories - Accessoires - toebehoor - Accessori - Accesorios

Doppeltüre

Double Door - Deuxième battant de porte - Tweede deurvleugel - Secondo battente - puerta doble

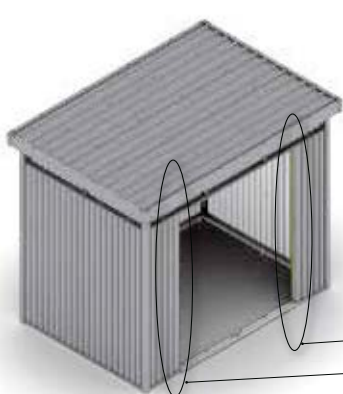

optionales Zubehör - Accessories - Accessoires - toebehoor - Accessori - Accesorios





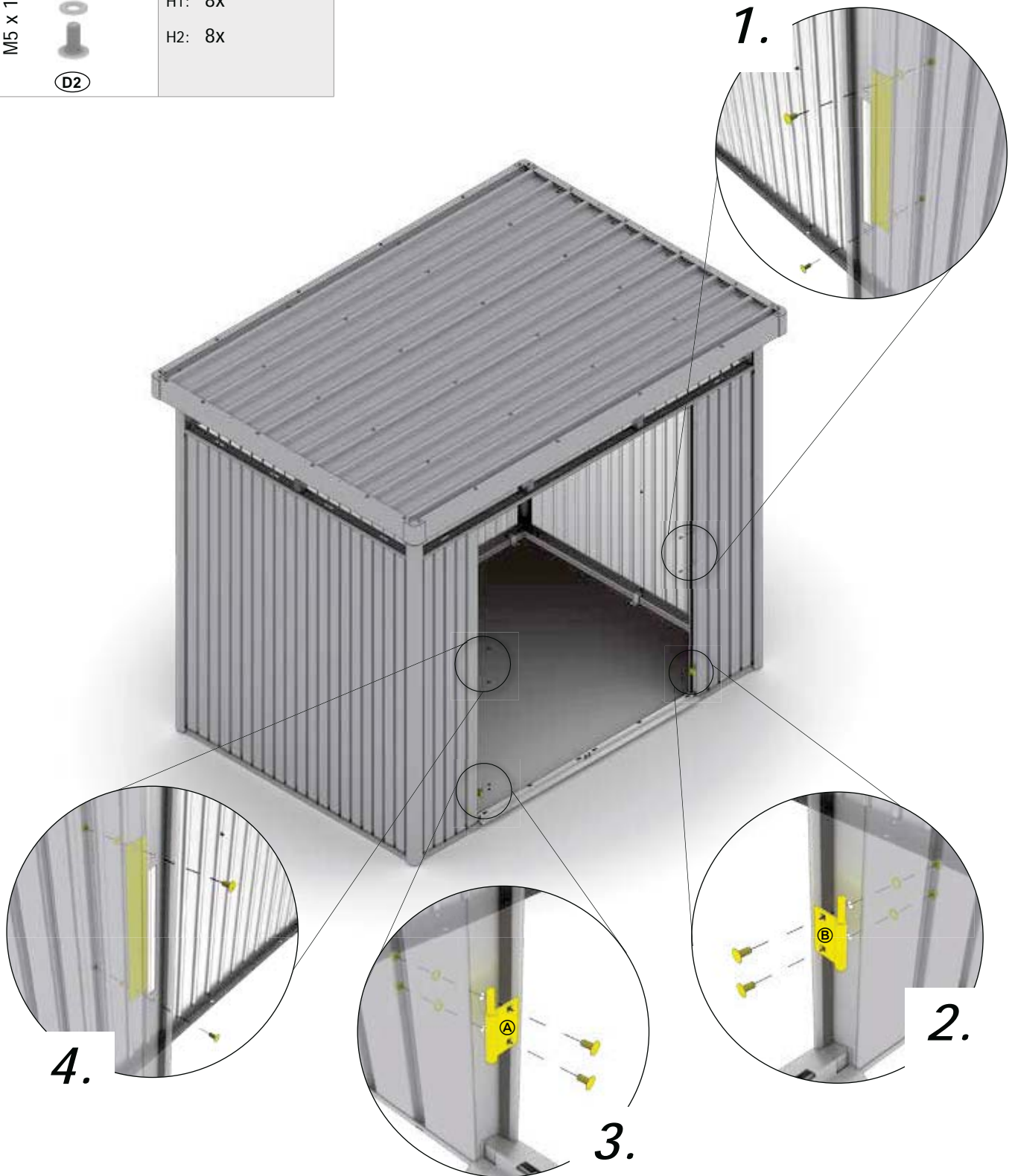

Doppeltüre

Double Door - Deuxième battant de porte - Tweede deurvleugel - Secondo battente - puerta doble

<p>I</p>	<p>1</p> <p>H1: 2x H2: 2x</p>	<p>D1</p>	<p>3</p> <p>H1: 1x H2: 1x</p>	<p>D1</p>	<p>3</p> <p>H1: 1x H2: 1x</p>
<p>M5 x 10</p> <p>D2</p>	<p>H1: 8x H2: 8x</p>				

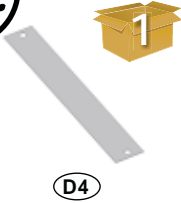

17.

 <p>(D4)</p>	H1: 1x H2: 1x	 <p>(D4)</p>	H1: 1x H2: 1x	 <p>M5 x 12 (D2) & (D4)</p>	H1: 2x H2: 2x
 <p>M5 x 10 (D2)</p>	H1: 8x H2: 8x	 <p>(D1)</p>	H1: 1x H2: 1x		



1.

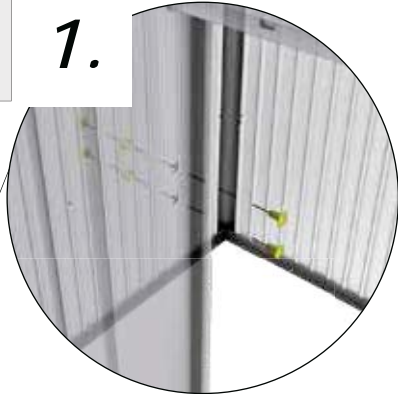

5.

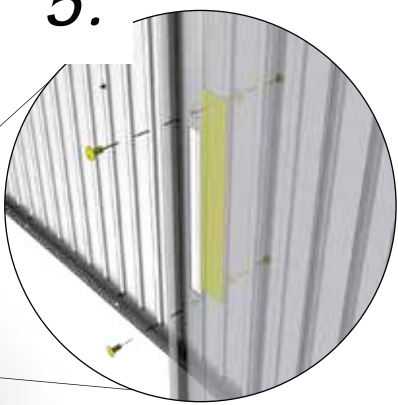

2.

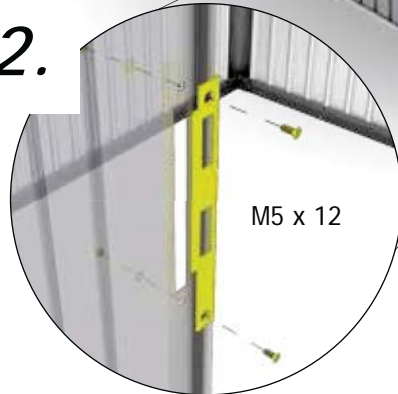

4.

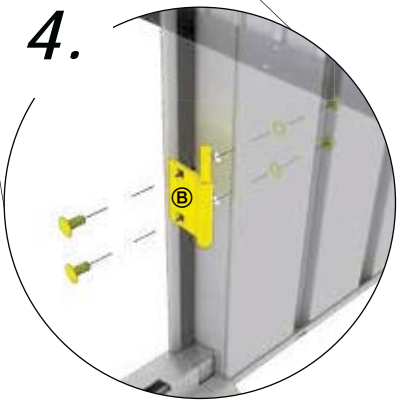

3.





Doppeltüre

Double Door - Deuxième battant de porte - Tweede deurvleugel - Secondo battente - puerta doble

<p>ⓑ</p>	<p>H1: 1x H2: 1x</p>	<p>Ⓐ</p> <p>ⓓ4</p>	<p>H1: 1x H2: 1x</p>	<p>M5 x 10</p> <p>ⓓ4</p>	<p>H1: 4x H2: 4x</p>
<p>ⓏA</p>	<p>H1: 1x H2: 1x</p>	<p>Ⓑ</p> <p>ⓓ4</p>	<p>H1: 1x H2: 1x</p>	<p>2.</p>	

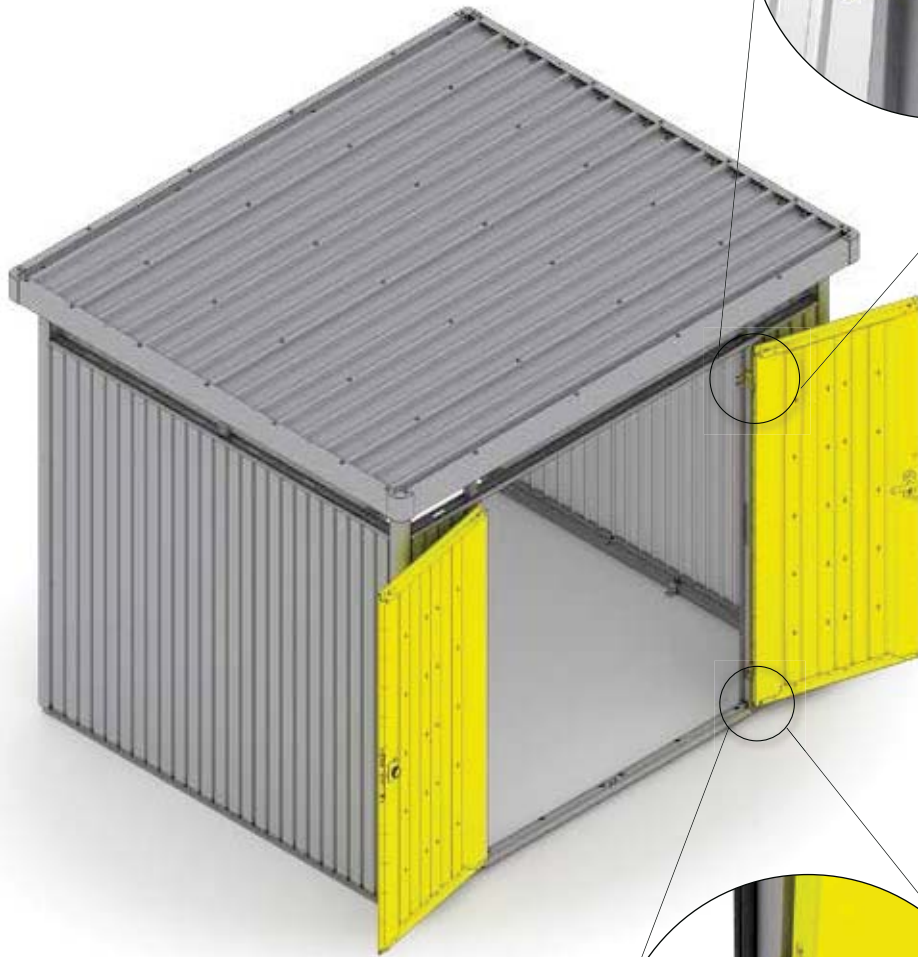

1.

18.

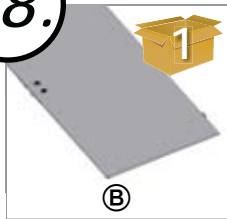

H1: 1x
H2: 1x



H1: 1x
H2: 1x

M5 x 10



H1: 2x
H2: 2x

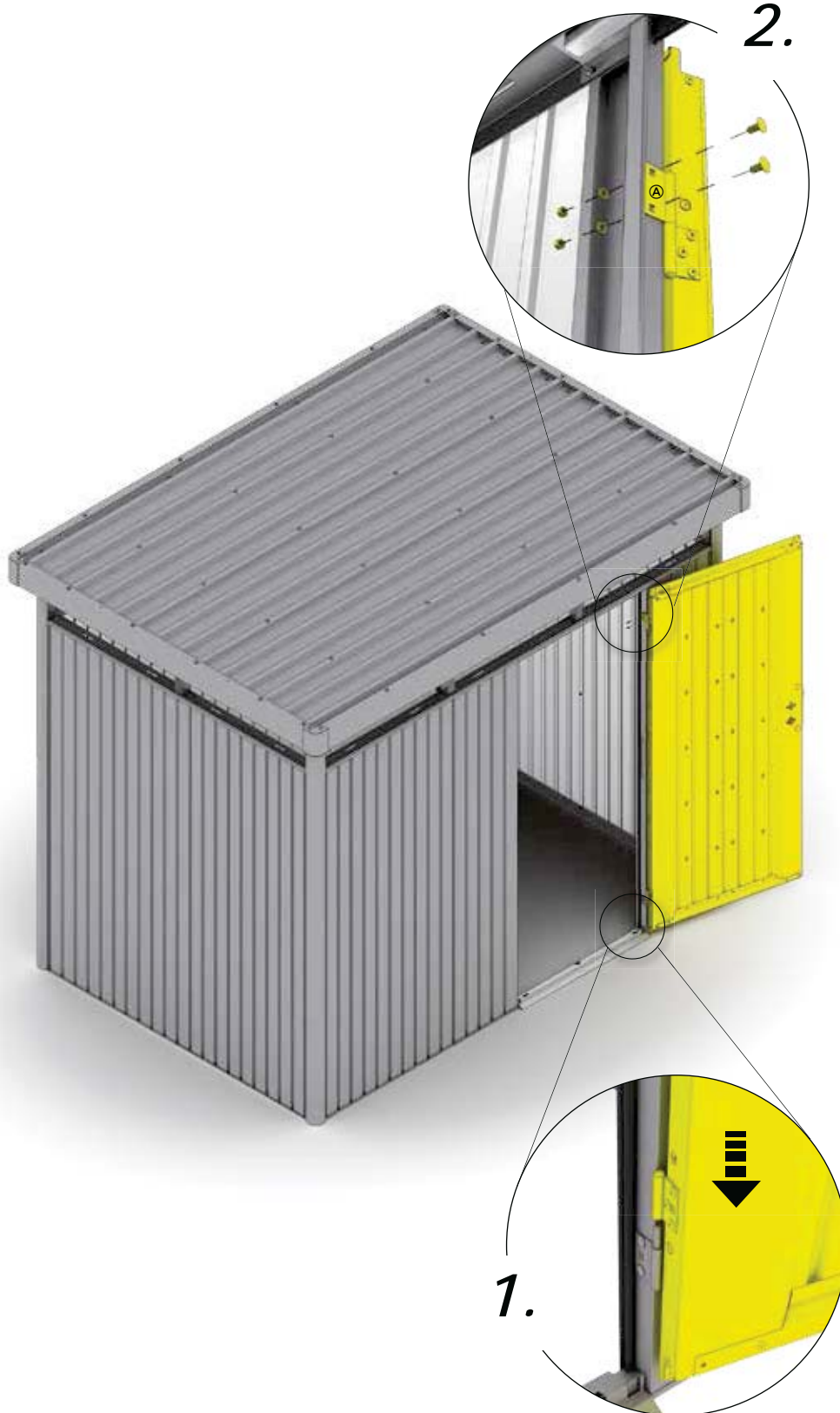

2.

1.

19.



D3

H2: 1x

H4: 1x

Reserveschlüssel für Nachfertigung separat aufbewahren!

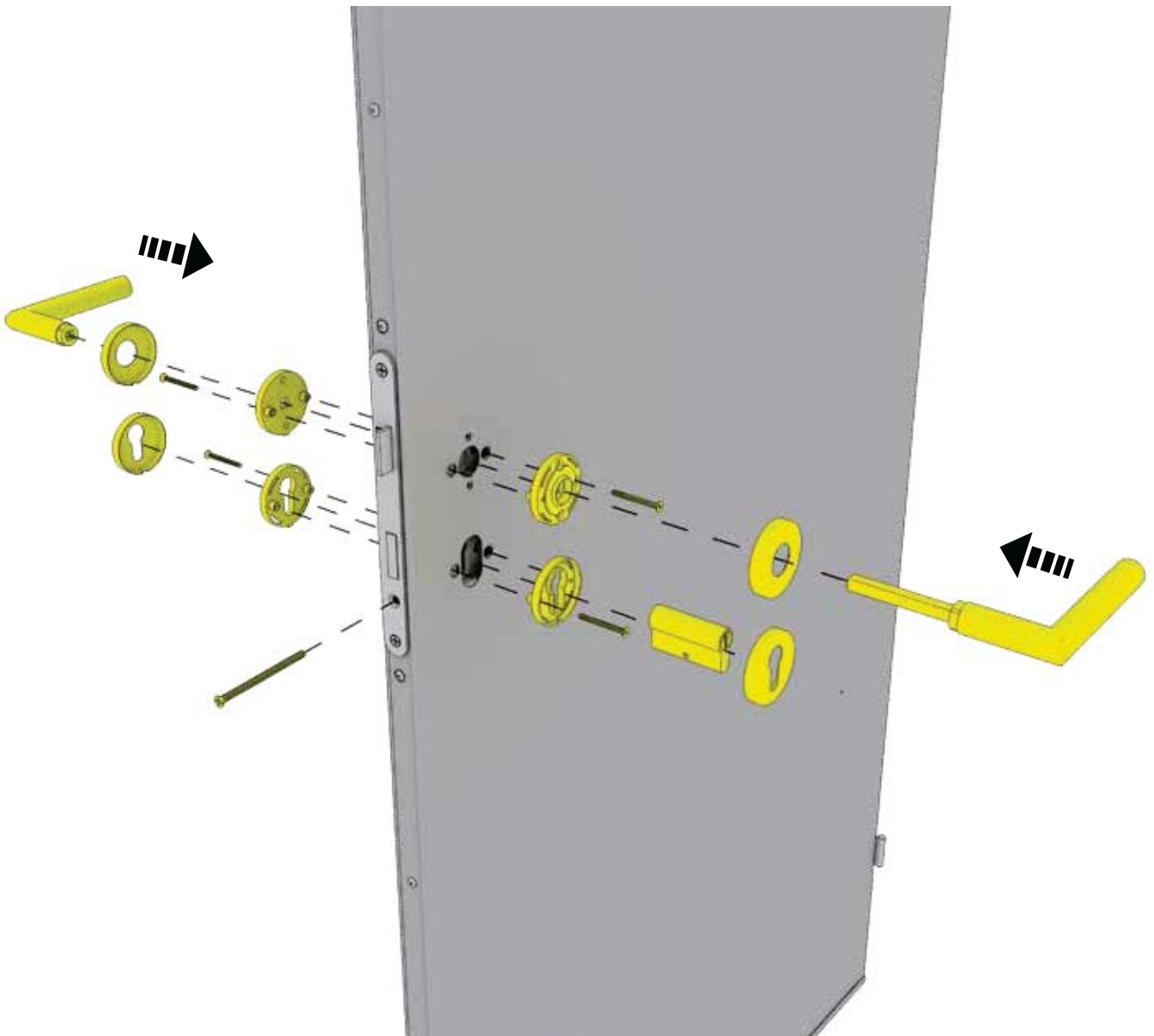

- Ⓒ GB Please keep a spare key separately in case you need to make copy
- Ⓒ FR Veuillez conserver vos clés de réserve séparément.
- Ⓒ NL Reservesleutel a.u.b. apart bewaren. Dit i.v.m. eventuele nabestellingen!
- Ⓒ ES Guarde una llave de repuesto separadamente por si tiene que encargar una copia.
- Ⓒ IT Conservare la chiave di riserva in luogo sicuro per un' eventuale post-fabbricazione!







Doppeltüre



Double Door - Deuxième battant de porte - Tweede deurvleugel - Secondo battente - puerta doble

 <p>Ⓚ</p>	<p>H1: 1x H2: 1x</p>	<p>4,8 x 13</p>  <p>ⓓ2</p>	<p>H1: 2x H2: 2x</p>
--	--------------------------	---	--------------------------



20.

 <p>H1: 1x H2: 1x</p> <p>ⓐ</p>	<p>4,8 x 13</p>  <p>ⓓ2</p>	<p>H1: 5x H2: 5x</p>	 <p>ⓓ1 & ⓓ4</p>	<p>H1: 1x H2: 1x</p>
---	---	--------------------------	--	--------------------------

<p>Doppeltüre <i>Double Door - Deuxième battant de porte - Tweede deurvleugel - Secondo battente - puerta doble</i></p>	 <p>H1: 2x H2: 2x</p> <p>ⓐ</p>	<p>H1: 5x H2: 5x</p>	<p>4,8 x 13</p>  <p>ⓓ2</p>	<p>H1: 10x H2: 10x</p>
 <p>H1: 2x H2: 2x</p> <p>ⓓ1 & ⓓ4</p>				



21.

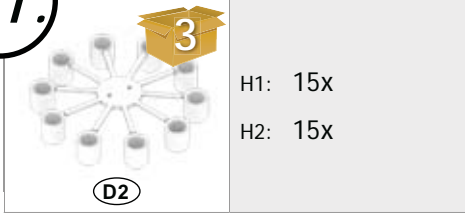

Rechtwinkelig einrichten

- Ⓒ rectangular adjusted
- Ⓕ ajuster en forme rectangulaire
- Ⓖ rechthoekig instellen
- Ⓔ ajustar en forma rectangular
- Ⓗ Mettere in squadra

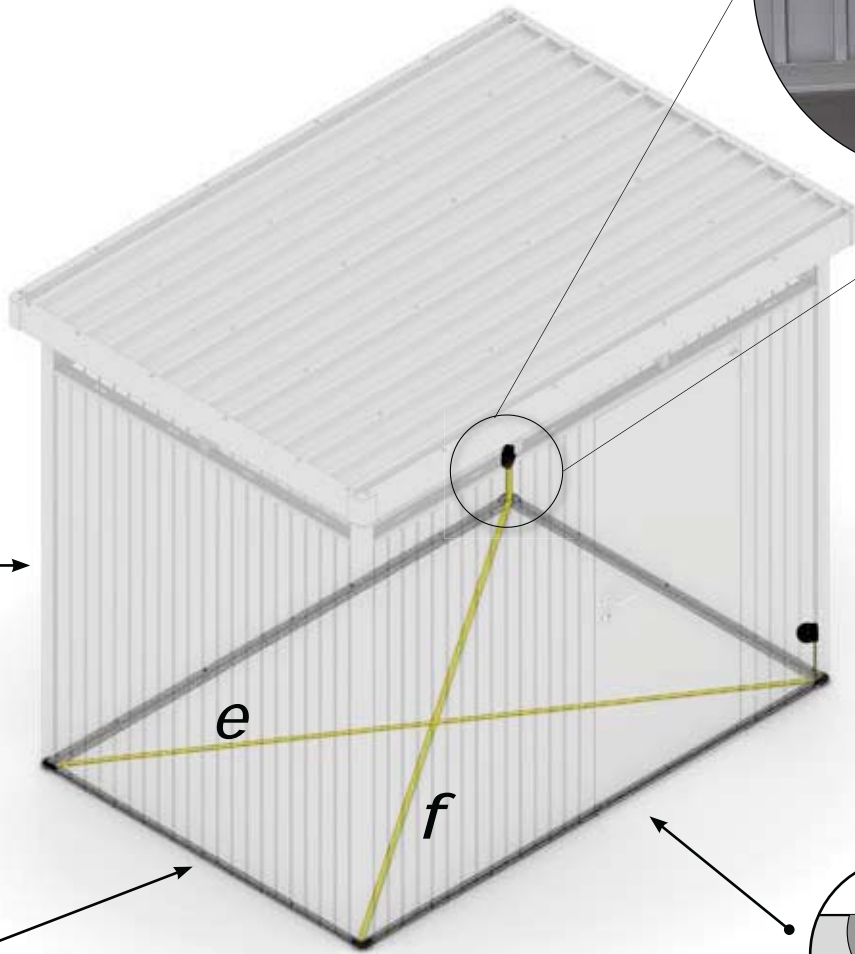
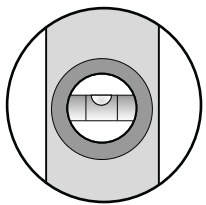

$$e = f$$



Ziehen Sie jetzt alle Schraubenverbindungen fest an!

*Tighten now all nuts and connections securely! - Serrez maintenant les vis à fond!
- Draai nu alle schroeven vast! - Ahora puede apretar y fijar todos los tornillos y tuercas - Adesso serrare a fondo tutti i dadi!*



22.

Tür einrichten

- Ⓒ align the door
- Ⓓ ajuster la porte
- Ⓖ deur afstellen
- Ⓔ ajuste la puerta
- Ⓣ messa a squadra della porta

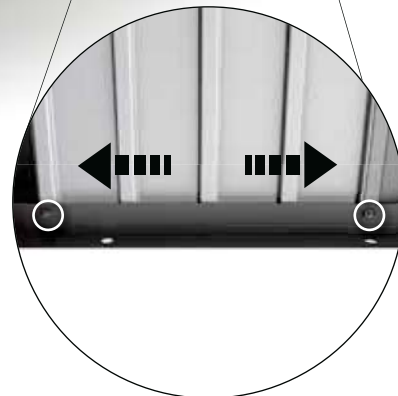
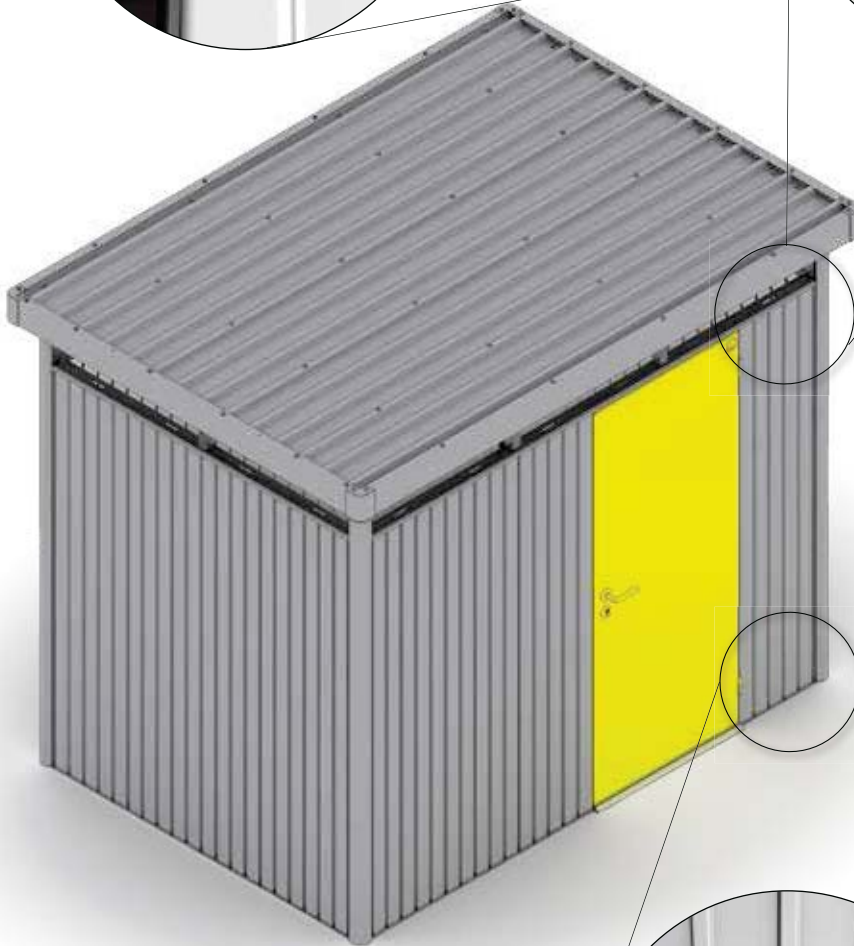
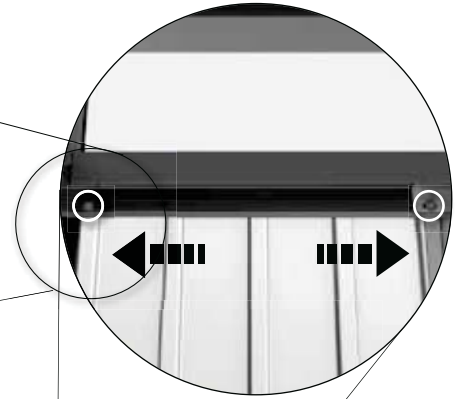
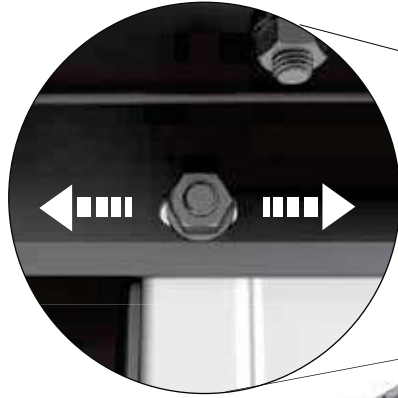

23.

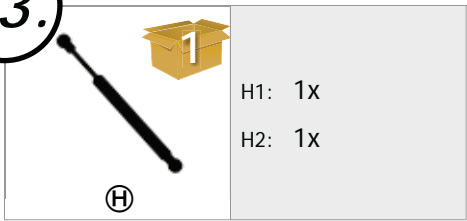

Doppeltüre

(Double Door - Deuxième battant de porte -
Tweede deurvleugel - Secondo battente -
puerta doble)

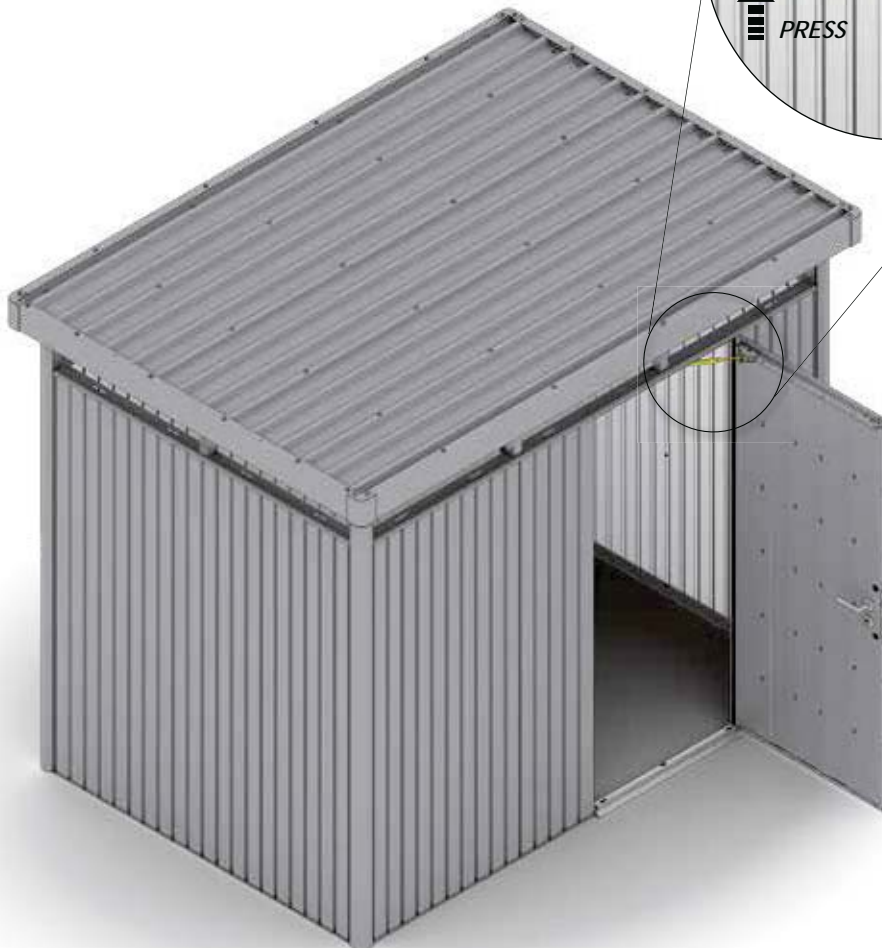
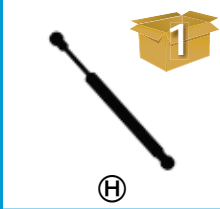

24.

M8 x 16



H1: 4x

H2: 4x

D2

Dachwölbung herstellen

- ⒸB tighten screws to arch the roof
- ⒻR surélevez le toit
- ⒼL dakwielving creëren
- ⒺS apriete los tornillos para conseguir el arqueamiento del techo
- ⒿT creare una volta del tetto



1.

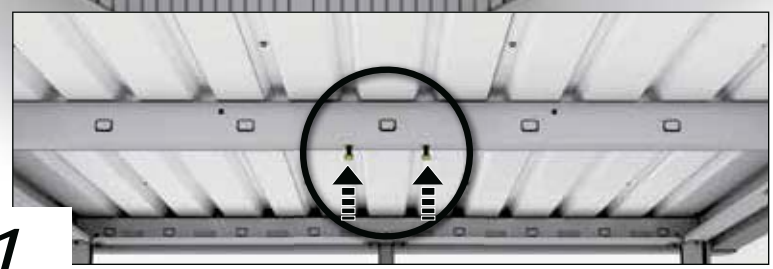

2.

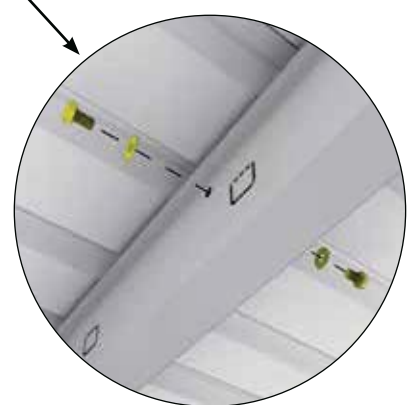
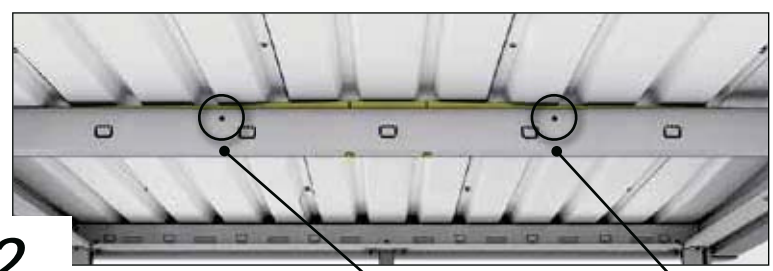



Bodenrahmen

Floor Frame - Cadre de sol - Telaio perimetrale - Bodemframe - marco de suelo

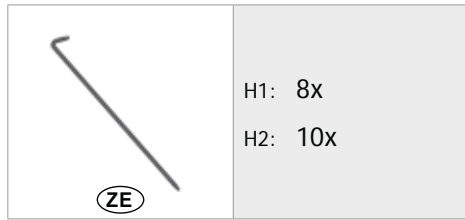

Variante 1 - (Seite 5), Proposal 1 - (page 5), Variant 1 - (page 5)

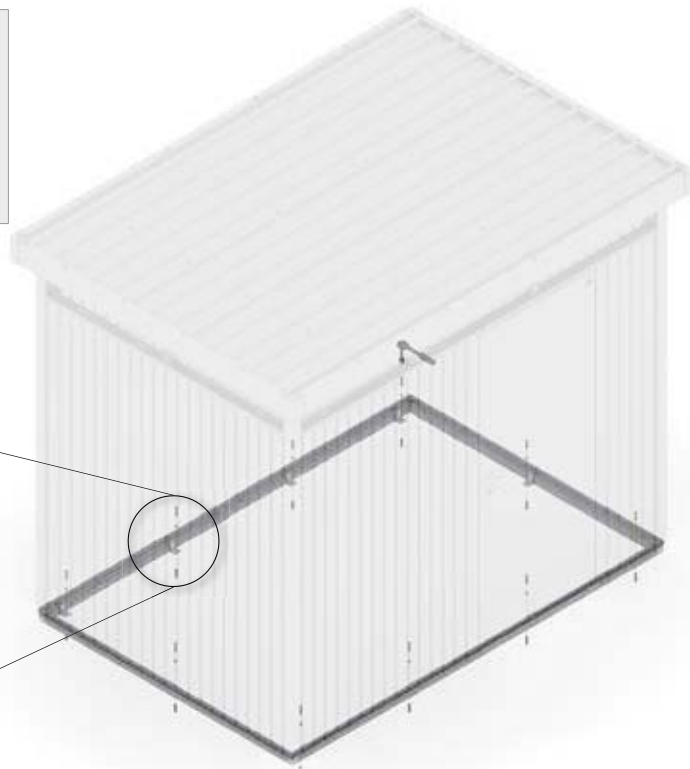
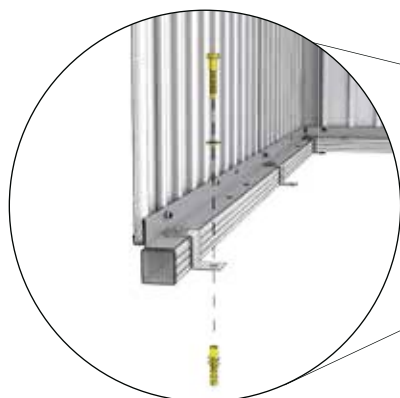
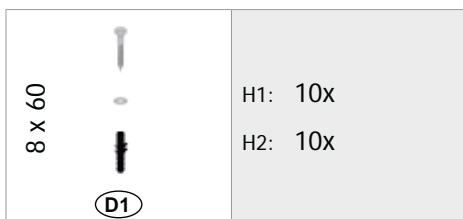

Variante 2 - (Seite 5), Proposal 2 - (page 5), Variant 2 - (page 5)





25.

8 x 60		H1: 10x
		H2: 10x
		

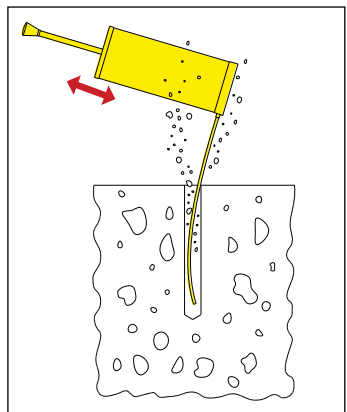
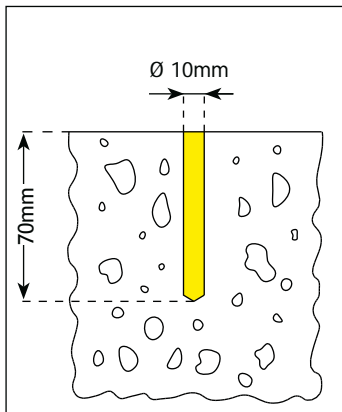
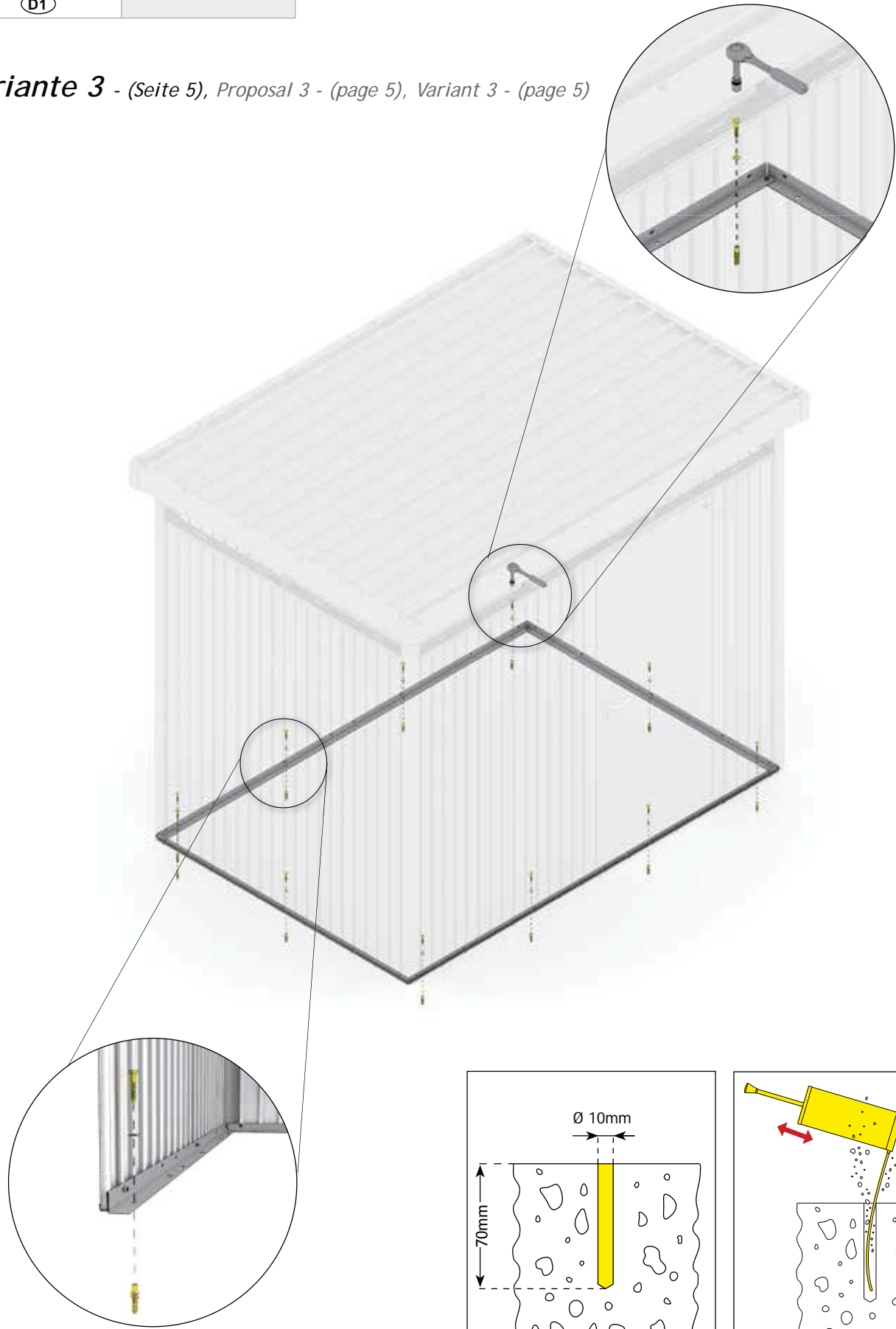
Variante 3 - (Seite 5), Proposal 3 - (page 5), Variant 3 - (page 5)





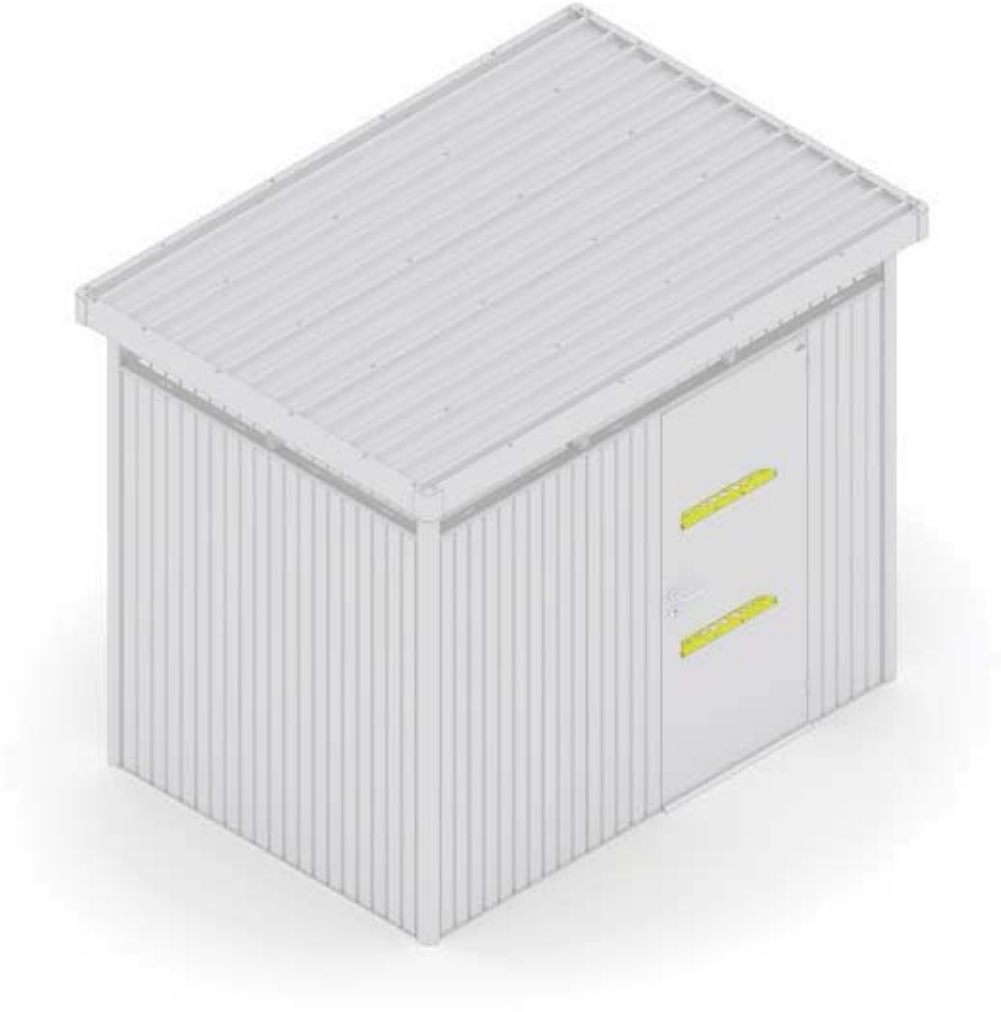
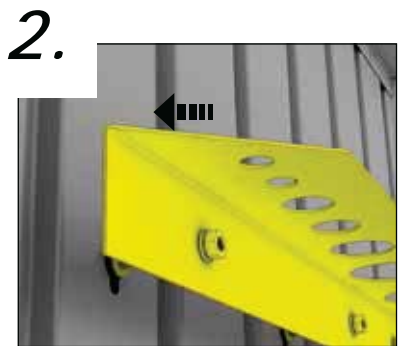
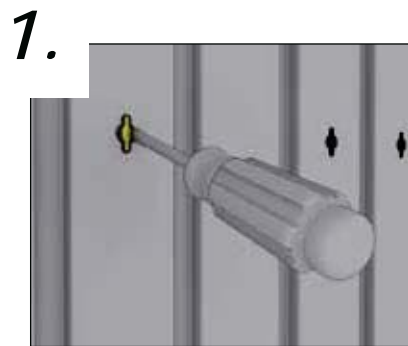

26.

 <p>Ⓔ</p>	<p>H1: 2x H2: 2x</p>	<p>M5 x 10</p>  <p>Ⓓ2</p>	<p>H1: 8x H2: 8x</p>
--	--------------------------	--	--------------------------



27.

 <p>3</p>	H1: 2x H2: 2x
 <p>4,8 x 9,5</p> <p>D1</p>	H1: 4x H2: 4x

 <p>5</p>	H1: 2x H2: 2x
 <p>AK</p>	

 <p>D1</p>	H1: 4x H2: 4x
---	------------------

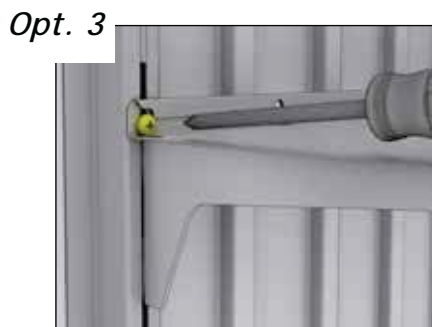
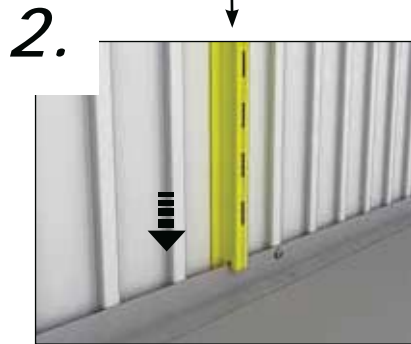
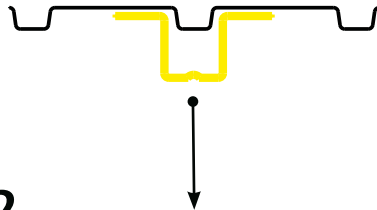

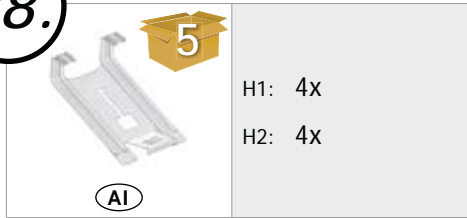

28.





Regenfallrohr - Option 1.

Rain water downpipe - Descente d'eaux pluviales - Regenpijpset - Set di tubi pluviali - Set de bajante

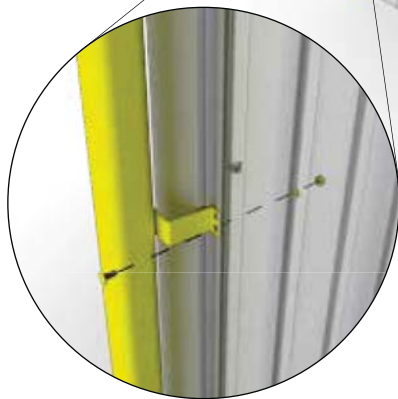
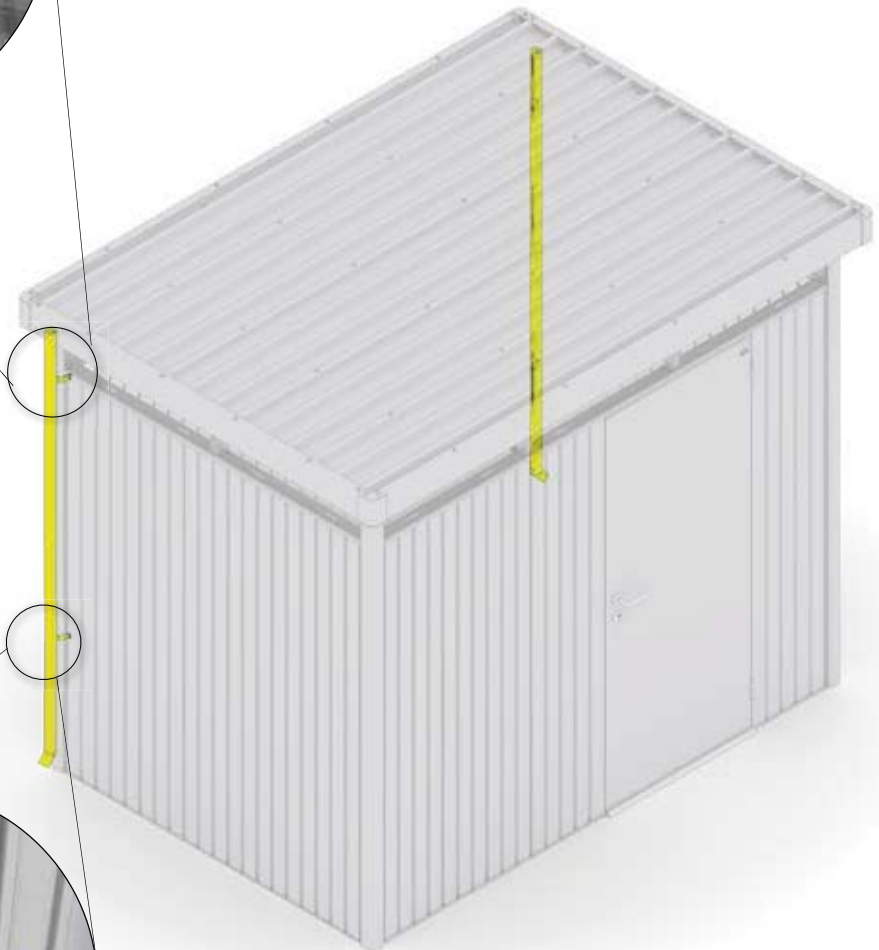

	H1: 2x		H1: 4x
	H2: 2x		H2: 4x





Regenfallrohr - Option 2.

Rain water downpipe - Descente d'eaux pluviales - Regenpijpset - Set di tubi pluviali - Set de bajante

	H1: 2x H2: 2x	M4 x 10 	H1: 2x H2: 2x	M4 x 18 	H1: 2x H2: 2x
---	------------------	--	------------------	--	------------------

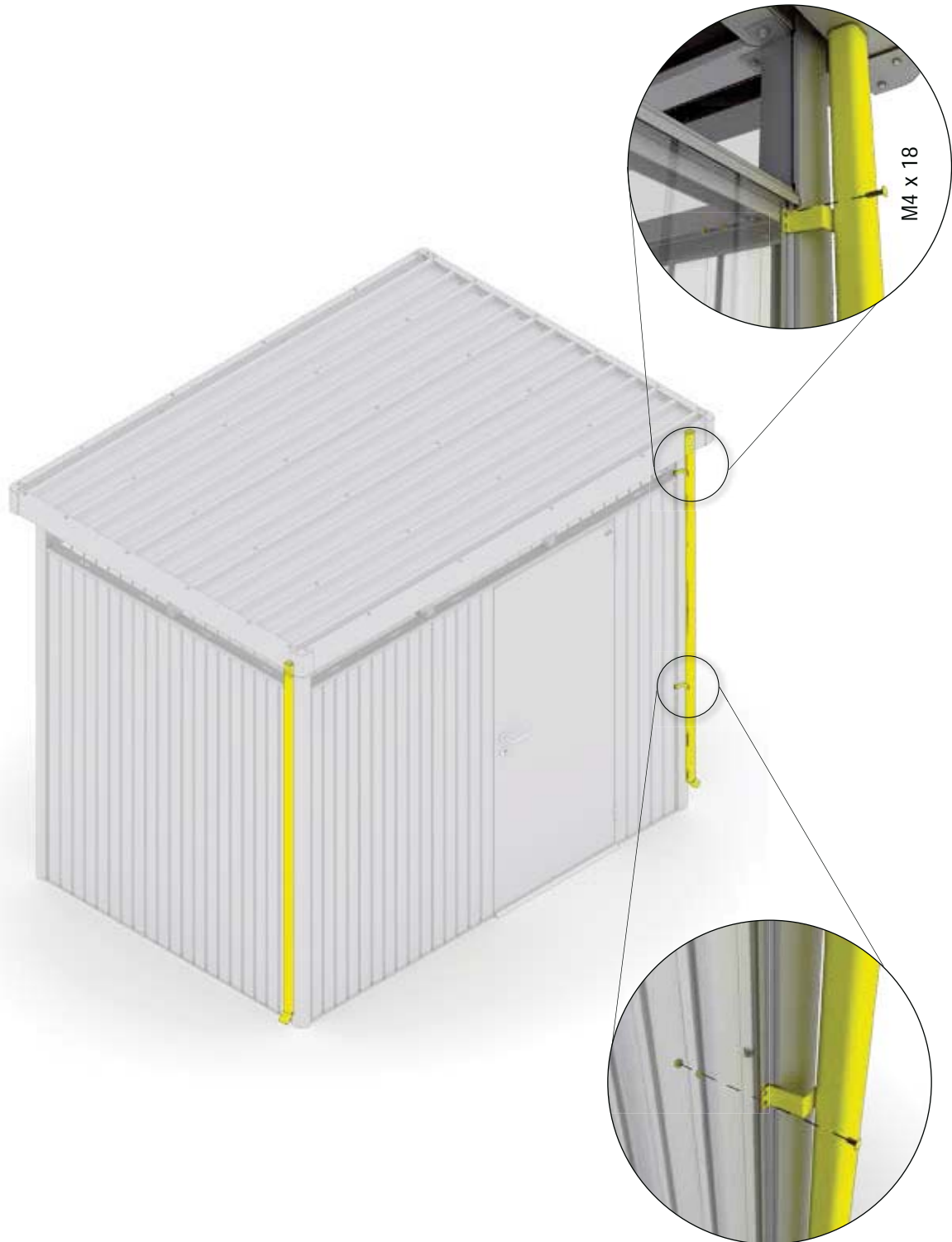

29.

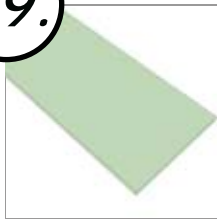

H1: 5X (1250 x 600mm)

H2: 6X (1250 x 600mm)

opt. Dachisolierung mit glatten XPS-Platten (3cm) (nicht im Lieferumfang)

Ⓒ GB ROOF INSULATION - polystyrene panels (3cm), (not in scope of supply)

Ⓒ FR PRÉPARATION POUR L'ISOLATION DU TOIT - plaques de styrodur (3cm),
(Pas inclus dans la livraison)

Ⓒ NL VOORBEREID VOOR DAKISOLATIE - piepschuimplaten (3cm), (niet in leveringsomvang)

Ⓒ ES PREPARACIÓN PARA EL AISLAMIENTO DE LA CUBIERTA - poliestireno (3cm),
(No incluido en el volumen de entrega)

Ⓒ IT PREDISPOSIZIONE PER LA COIBENTAZIONE DEL TETTO - di pannelli in polistirolo (3cm),
(non forniti in dotazione)

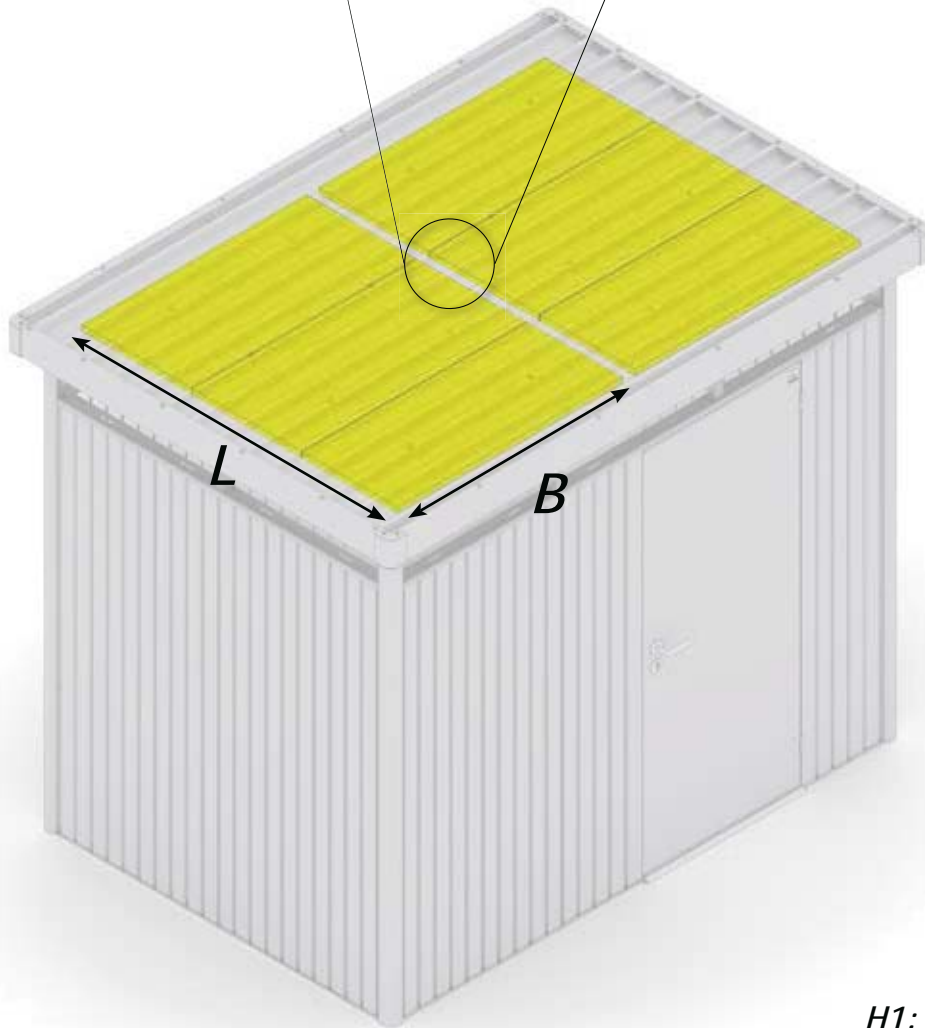
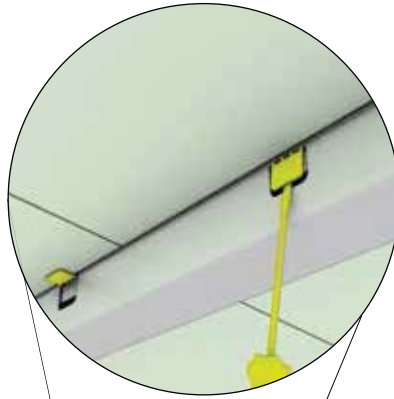

H1: L = 1315mm
B = 1225mm

H2: L = 1715mm
B = 1225mm

Abmessungen Gerätehaus „HighLine“

Dimensions de la dépendance HighLine

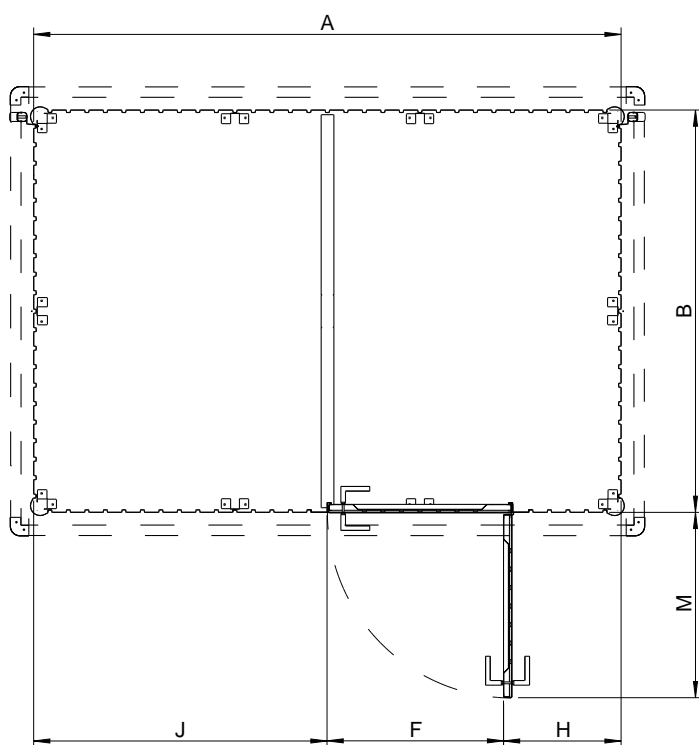
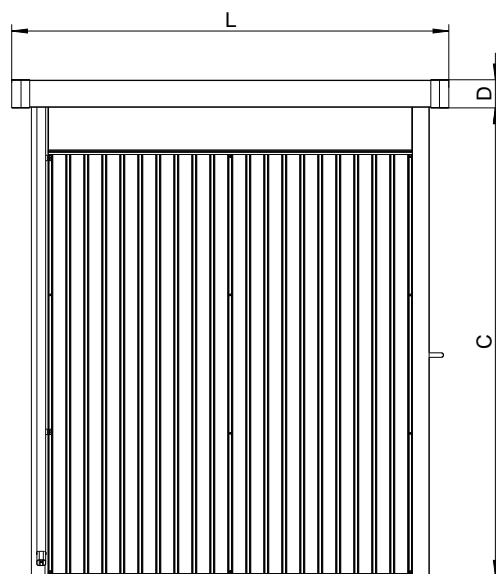
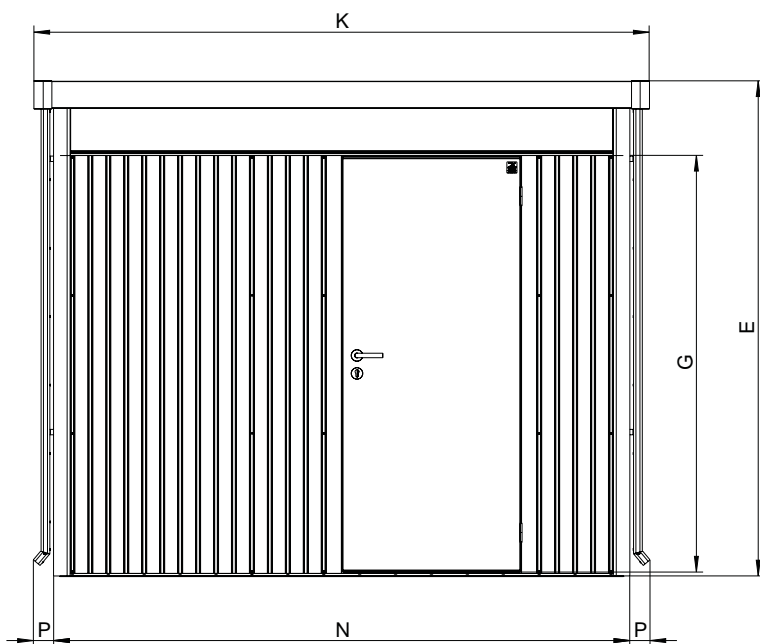

	HighLine H1	HighLine H2
A	2540 mm	2540 mm
B	1340 mm	1740 mm
C	2095 mm	2095 mm
D	125 mm	125 mm
E	2220 mm	2220 mm
F	760 mm	760 mm
G	1820 mm	1820 mm
H	510 mm	510 mm
J	1270 mm	1270 mm
K	2750 mm	2750 mm
L	1550 mm	1950 mm
M	800 mm	800 mm
N	2570 mm	2570 mm
P	90 mm	90 mm

Einreichplan

für die Aufstellung eines
Biohort-Gerätehauses
Modell „HighLine“

Approval plan

for the erection of
Biohort garden shed
model "HighLine"

Demande

d'autorisation pour la
mise en place d'un
abri de jardin Biohort
Modèle « HighLine »

Plan van goedkeuring

voor het bouwen van
het Biohort tuinhuis
model "HighLine"

Adresse Aufstellort / Address at site of erection / Adresse du terrain / Platsingsadres

Grundbuch-Einlagezahl
Land register-Site No. / Cadastre
Katastralgemeinde

Grundstücks-Nr.
Property No. / Parcelle n°
Kadastraal nummer

Katastralgemeinde
Council/Borough responsible
Section/Commune / Eigendomsnummer

Bauerber

Building applicant

Demandeur / Opbouwer

Vorname / Christian name / Prénom / Voornaam Familienname / Surname / Nom / Achternaam

Anschrift / Address / Adresse / Adres

Unterschrift des Bauerbers / Signature of applicant / Signature du demandeur / Handtekening eigenaar

Grundstückseigentümer

Property owner

Propriétaire du terrain

Landeigenaar

Vorname / Christian name / Prénom / Voornaam Familienname / Surname / Nom / Achternaam

Anschrift / Address / Adresse / Adres

Unterschrift des Grundstückseigentümers / Signature of property owner
Signature du propriétaire / Handtekening eigenaar

Bodenfläche des Biohort-Gerätehauses:

Floorspace of biohort garden shed:

Surface au sol de l'abri de jardin Biohort :

Oppervlakte van het Biohort tuinhuis:

o Größe H1 / Size H1 / Taille H1 / Grootte H1 = 3,4 m²

o Größe H2 / Size H2 / Taille H2 / Grootte H2 = 4,4 m²

Gesamte bebaute Fläche

Total built-up area / Surface totale bâtie / Totaal bebouwde oppervlakte

Gartenfläche

Garden area / Surface du jardin / Tuin oppervlakte

Altbau bewilligt

Erection authorised by

Permis de construire du bâtiment existant sur le terrain N°

Opdracht tot opbouw door

vom

Date / En date du / Datum

Verein

Association / Société / Vereniging

Lageplan 1 : 500

Siteplan 1 : 500

Plan de masse 1 : 500

Map 1 : 500