

ASSEMBLY INSTRUCTIONS

MONTAGEANLEITUNGEN

N634P190873S

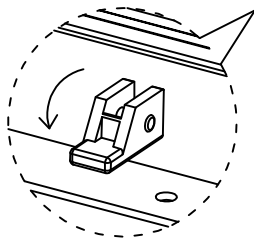
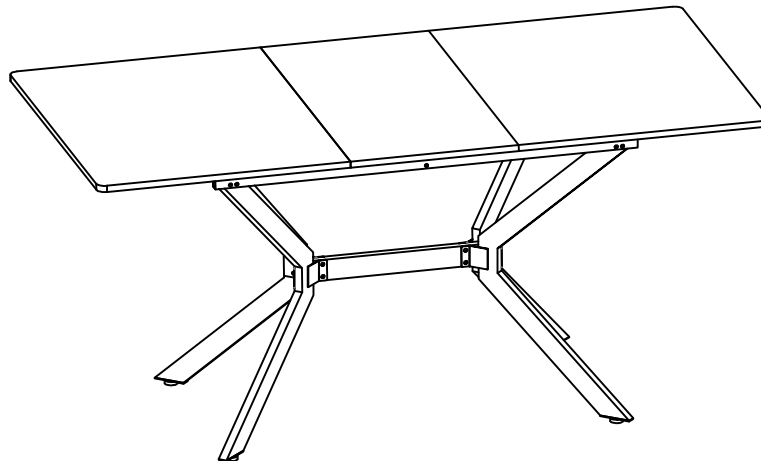

Lösen Sie die Verriegelung

Release the latch

Desserrer le loquet

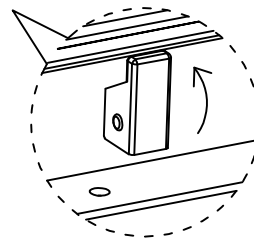
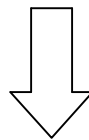



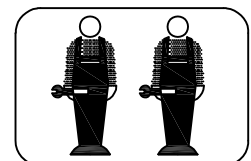
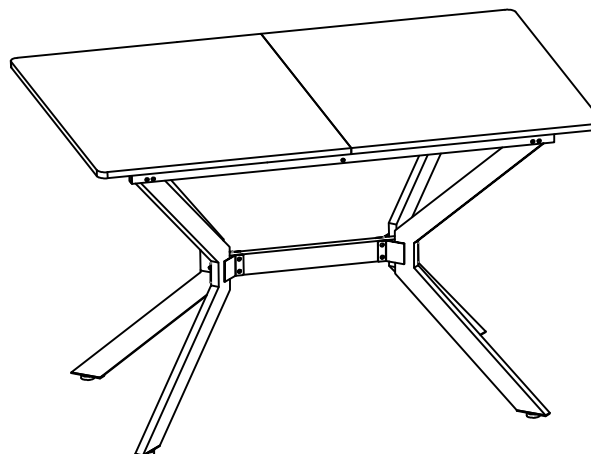

Verriegeln Sie die Verriegelung

Lock the latch

Verrouillé le loquet



			
M6×15mm	M6×12mm	φ18×1.8mm	φ19×3mm
Ⓒ×20pcs	Ⓓ×4pcs	Ⓕ×8pcs	Ⓖ×4pcs

Bitte beachten Sie, dass die Formen der Schrauben C und D ähnlich sind, F und G ähnlich sind. Bitte installieren Sie entsprechend der Anleitung und unterscheiden Sie sie!

Please note that the shapes of screws C and D are similar, F and G are similar. Please install according to the instructions and distinguish them!

Notez que les vis C et D ont des formes similaires, F et G ont des formes similaires. Veuillez les installer en suivant les instructions pour les séparer!



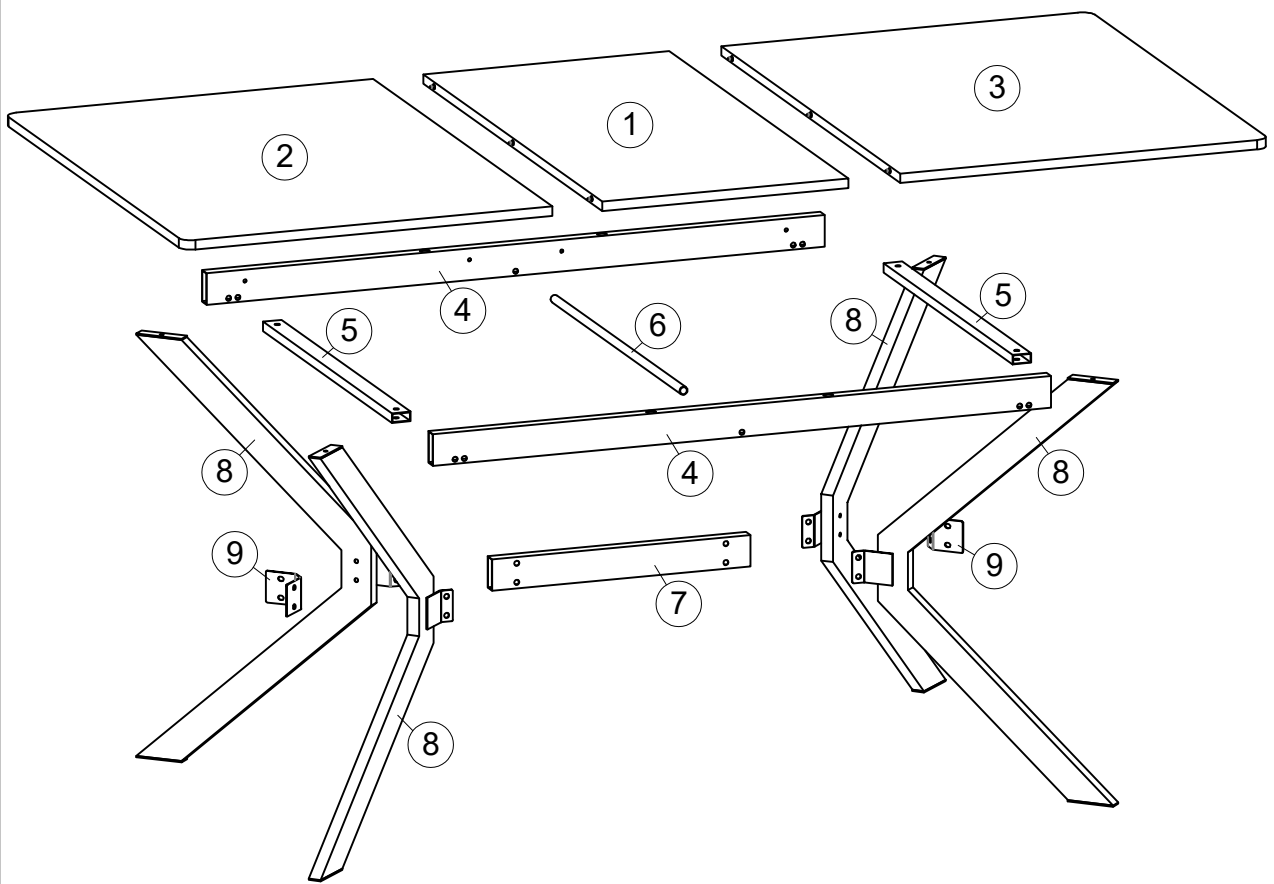

Vor dem Einbau die Schrauben in die Löcher stecken und festziehen, aber nicht bis 100%, 70% bis 80% anziehen reicht aus. Schließlich, nachdem alle Schrauben installiert sind, ziehen Sie alle Schrauben auf 100%. Wenn Sie auf diese Probleme stoßen, z.B. wenn die Löcher nicht ausgerichtet werden können oder einige Teile nicht installiert werden können, überprüfen Sie bitte, ob die Schrauben korrekt verwendet werden und passen Sie die Dichtheit der Schrauben an.

Before installation, insert the screws into the holes and tighten them, but do not tighten them to 100%, 70% to 80% is sufficient. Finally, after all screws are installed, tighten all screws to 100%. If you encounter these issues, such as if the holes cannot be aligned or some parts cannot be installed, please check if the screws are used correctly and adjust the tightness of the screws.



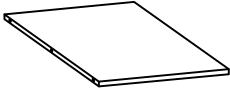
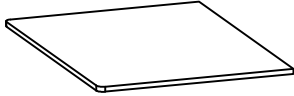
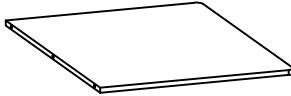

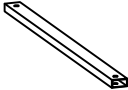
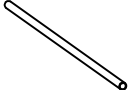

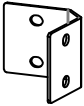

Insérer la vis dans le trou avant la fin de l'assemblage, serrer la vis, mais ne pas serrer à 100%, 70% ~ 80% est bien. Enfin, une fois que toutes les vis sont bien serrées, toutes les vis sont serrées à 100%. Si vous rencontrez ces problèmes, par exemple si les trous ne sont pas alignés ou si certaines pièces ne peuvent pas être montées, vérifiez que les vis sont utilisées correctement et ajustez leur serrage.

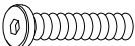
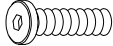

Part List
Stückliste

			
①×1pc	②×1pc	③×1pc	④×2pcs
			
⑤×2pcs	⑥×1pc	⑦×1pc	⑧×4pcs
			
⑨×2pcs			

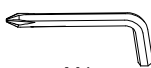



Hardware List
Hardwareliste

 M6×40mm	 M6×25mm	 M6×15mm	 M6×12mm	 M6×17mm
Ⓐ×10pcs	Ⓑ×8pcs	Ⓒ×20pcs	Ⓓ×4pcs	Ⓔ×4pcs
 φ18x1.8mm	 φ19x3mm		 M4	
Ⓕ×8pcs	Ⓖ×4pcs	Ⓗ×4pcs	Ⓘ×2pcs	Ⓣ×2pcs
 M4×12mm				
Ⓚ×8pcs				

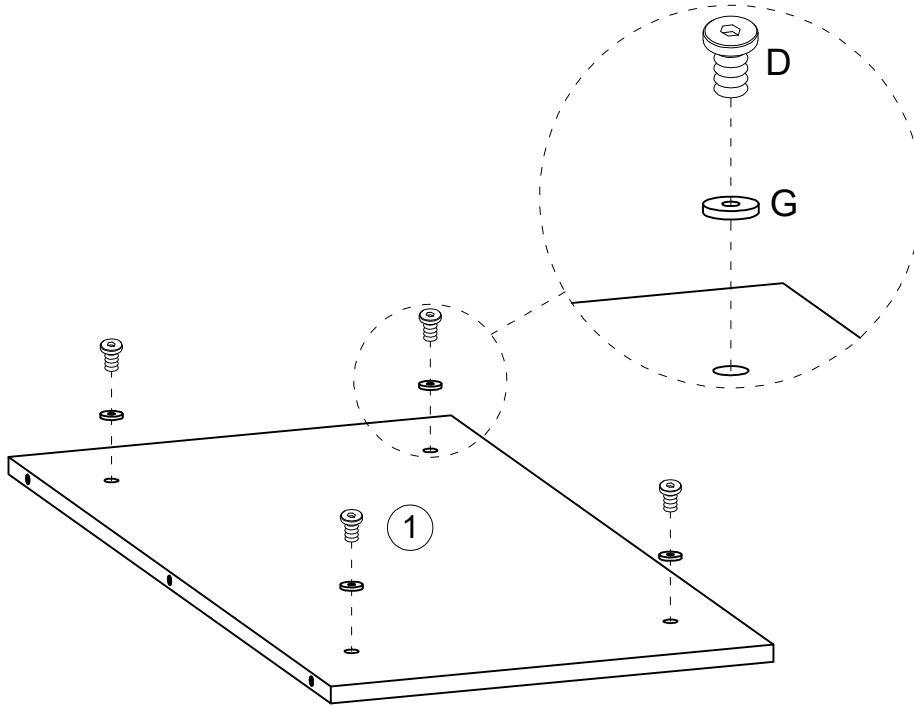

Step 1
Schritt 1

	
φ19x3mm	M6×12mm
ⓐ ×4pcs	ⓓ ×4pcs



	
φ19x3mm	M6×12mm
	
φ18x1.8mm	M6×15mm

Step 2
Schritt 2

	
M4×12mm	
Ⓚ ×8pcs	ⓙ ×2pcs

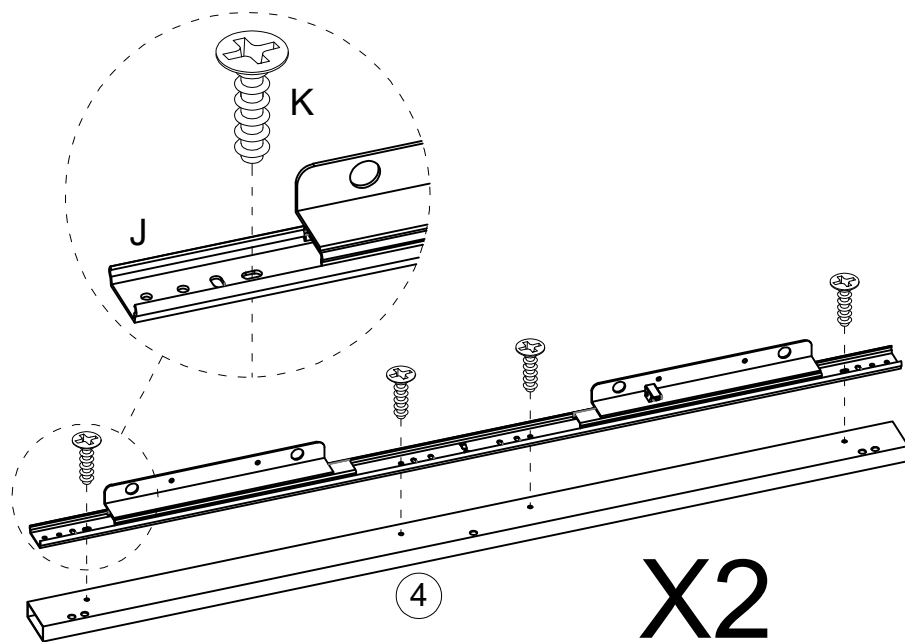

Step 3
Schritt 3

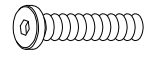

M6×40mm

Ⓐ×10pcs

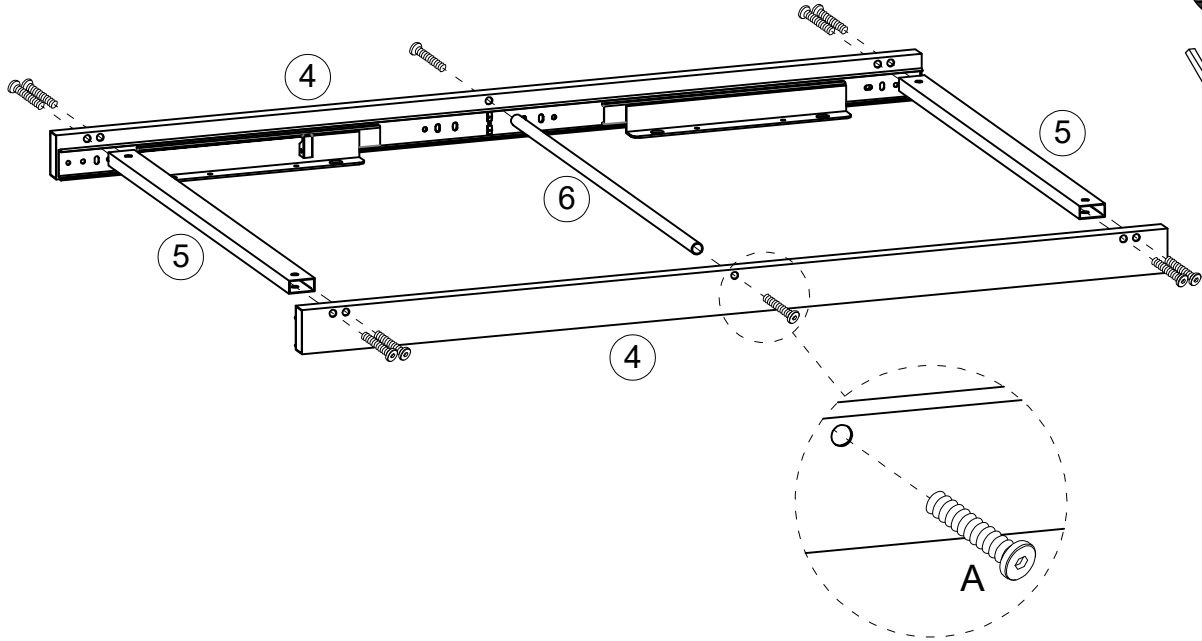

Step 4
Schritt 4



M6×25mm

Ⓑ×4pcs

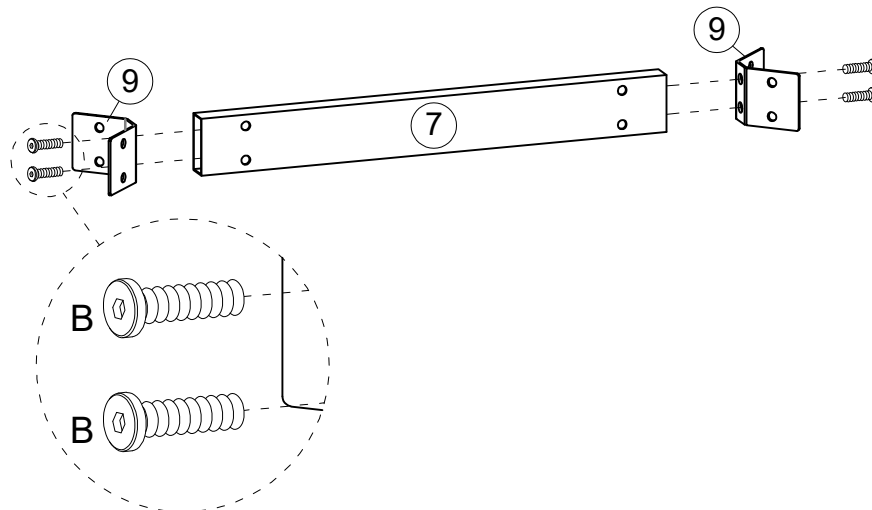

Step 5
Schritt 5

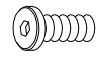
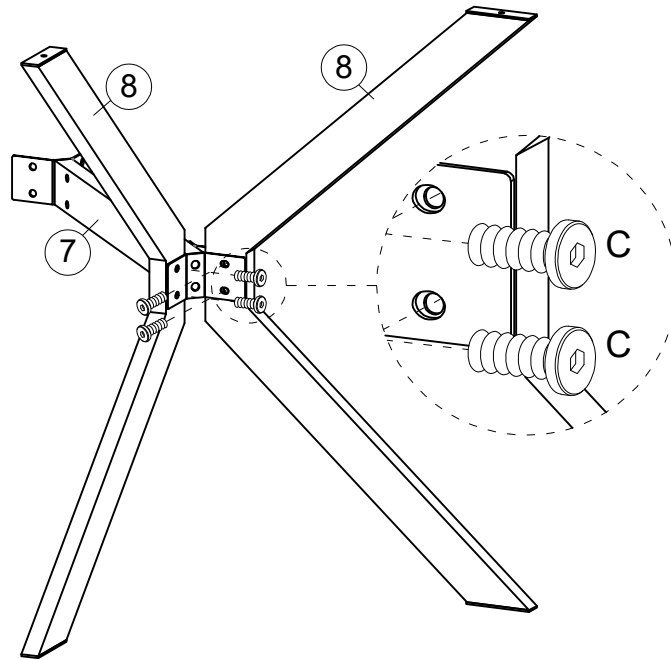

M6×15mm

Ⓢ ×4pcs

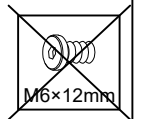

M6×12mm

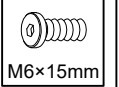

M6×15mm

Step 6
Schritt 6

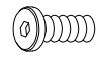
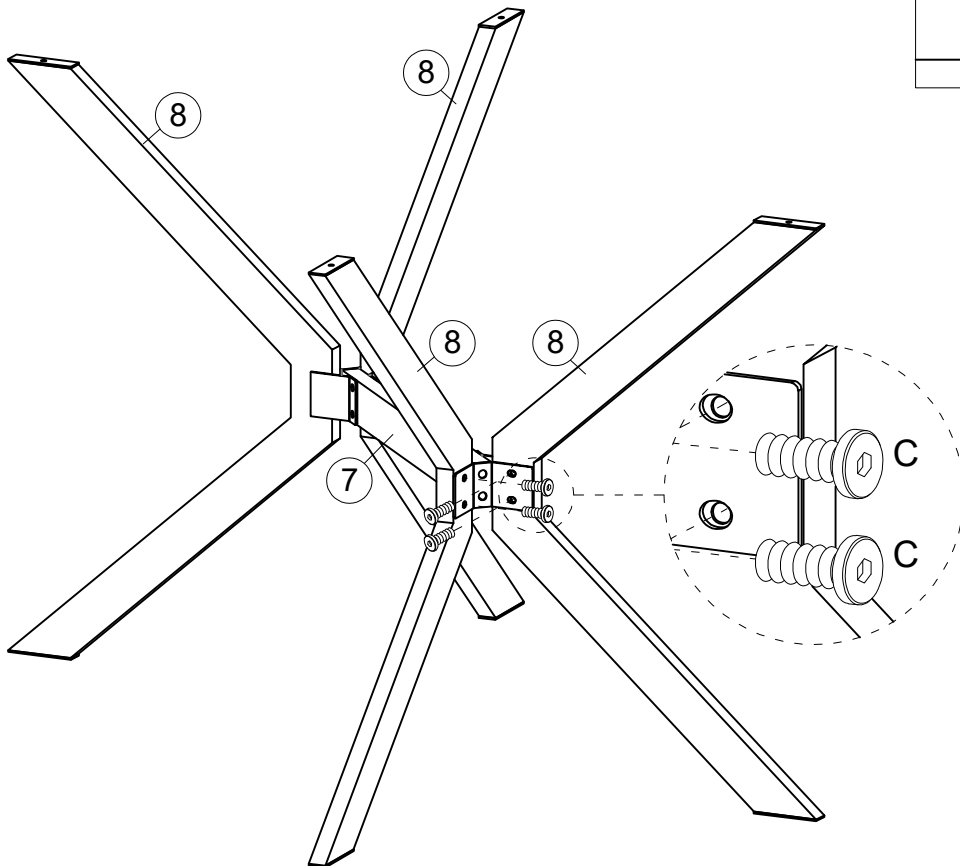

M6×15mm

Ⓢ ×4pcs

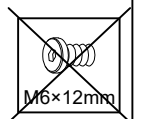



M6×12mm



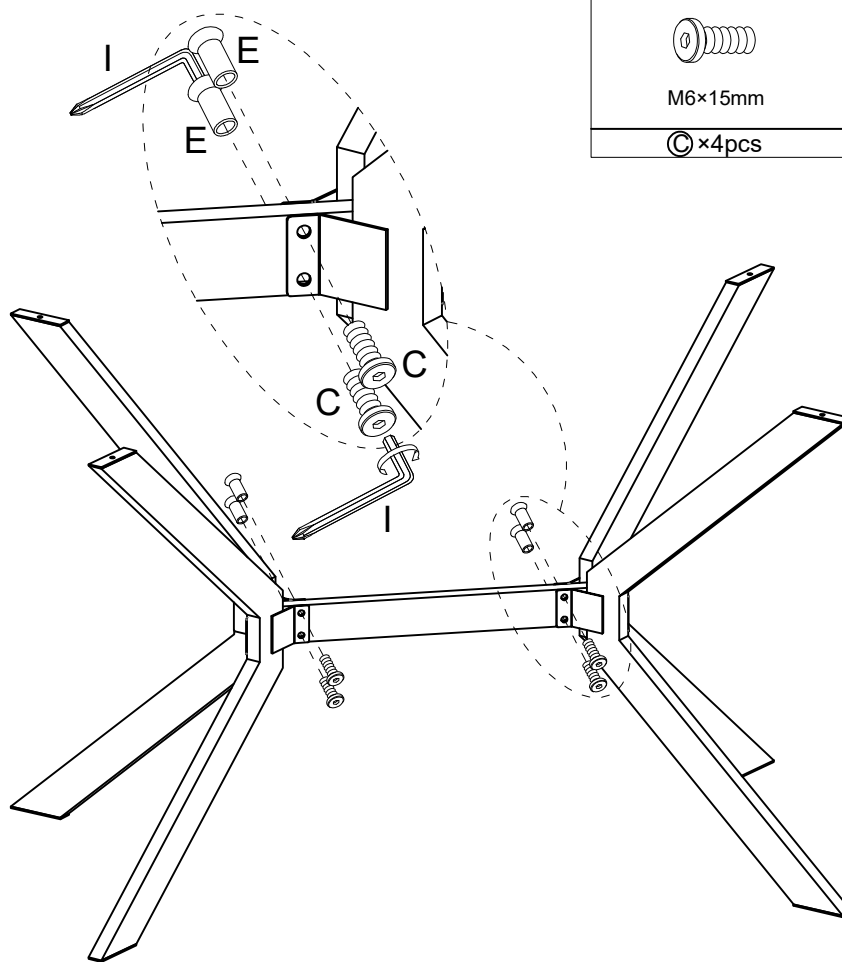

M6×15mm

Step 7
Schritt 7



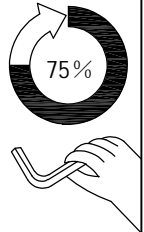

	
M6×15mm	M6×17mm
Ⓒ×4pcs	Ⓔ×4pcs



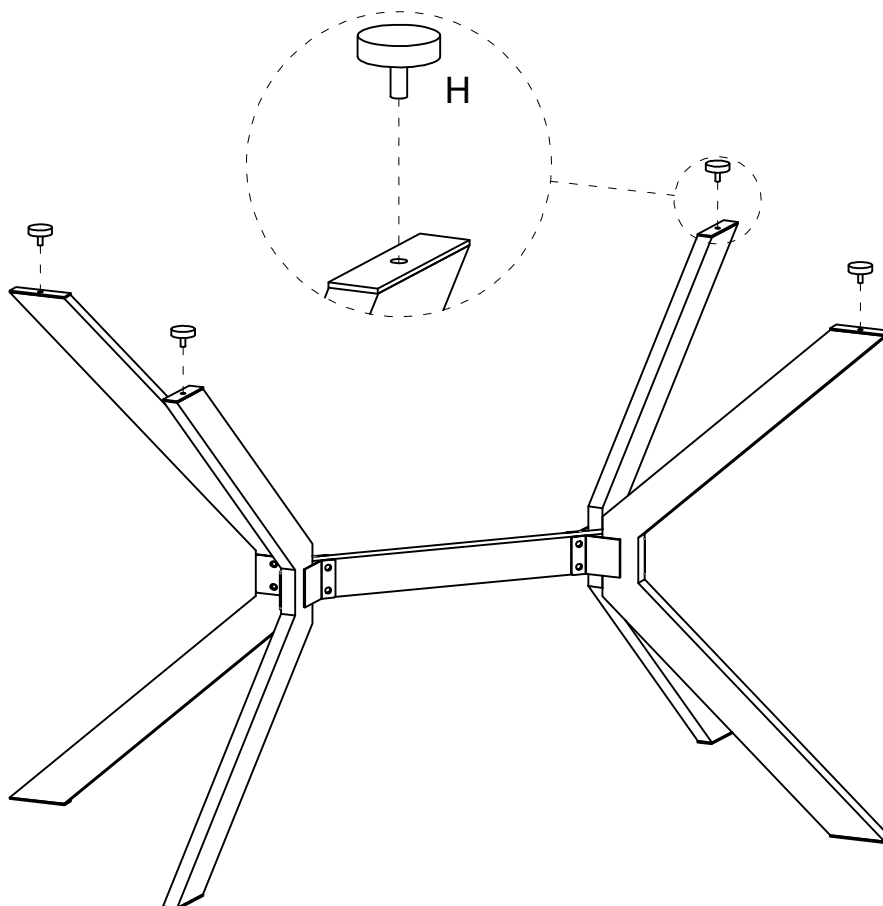

M6×12mm

M6×15mm

Step 8
Schritt 8



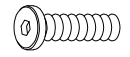

Ⓕ×4pcs

Step 9 Schritt 9

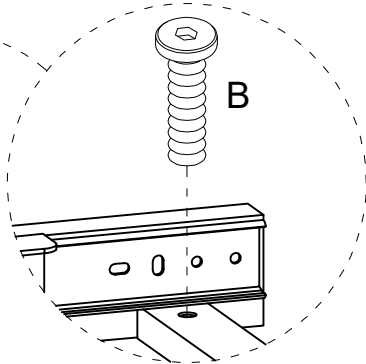
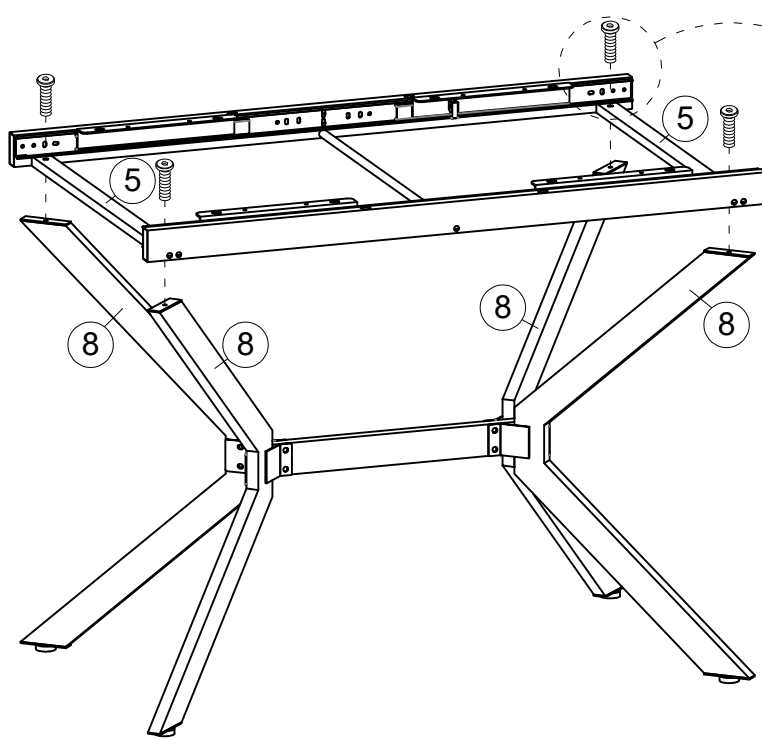

M6×25mm

Ⓑ×4pcs



Step 10 Schritt 10



M6×15mm

Ⓒ×8pcs



φ18×1.8mm

Ⓕ×8pcs

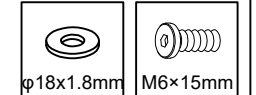
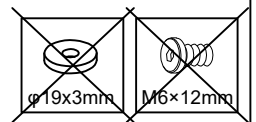
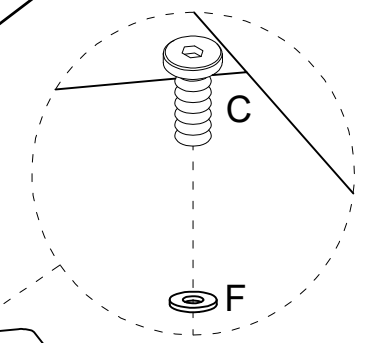
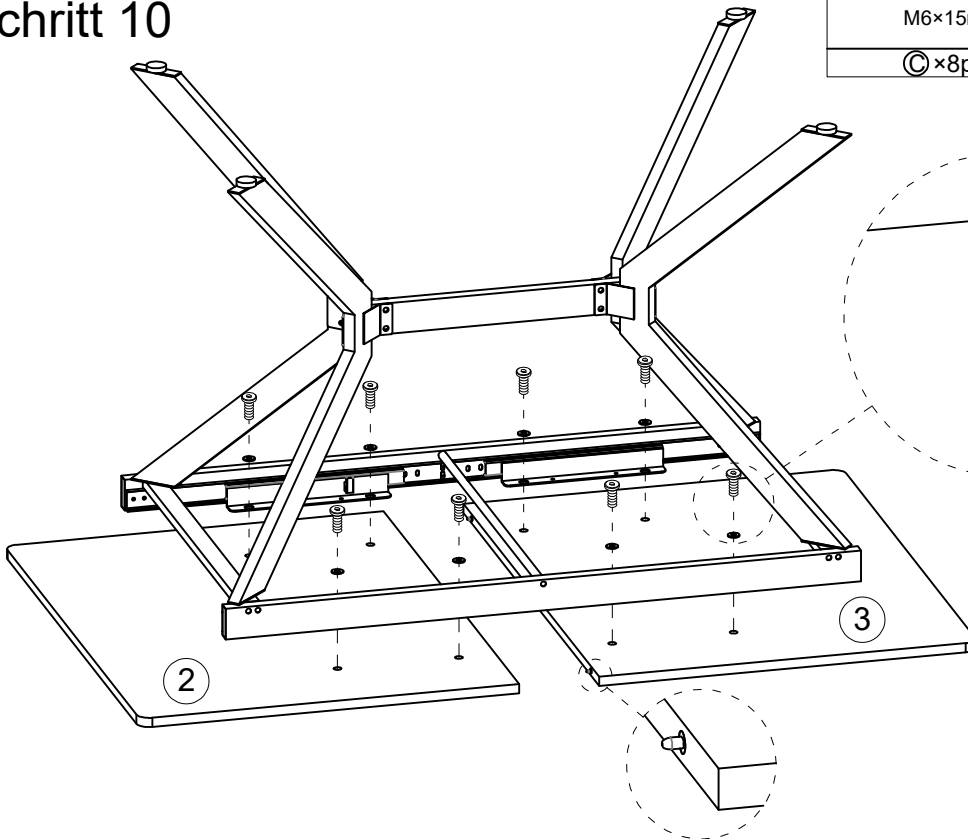

Step 11
Schritt 11

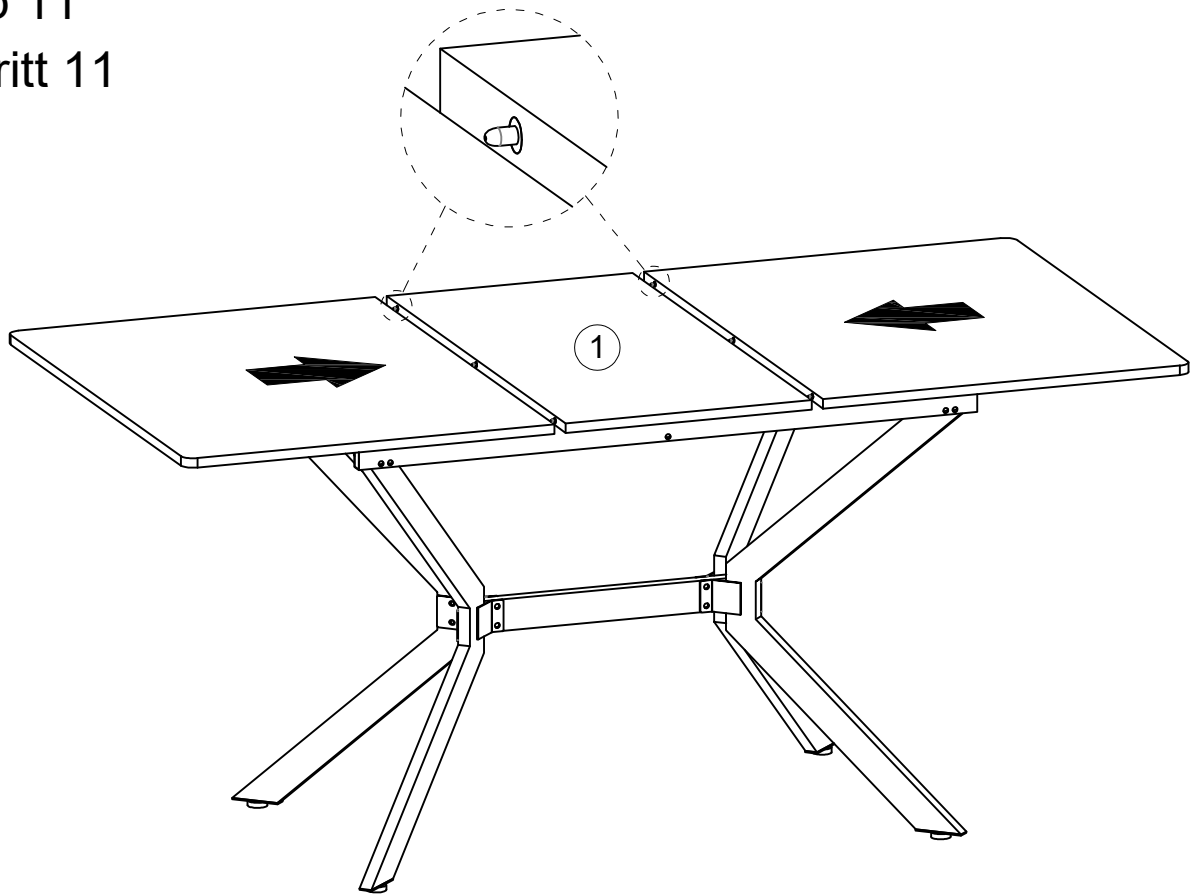

Step 12
Schritt 12

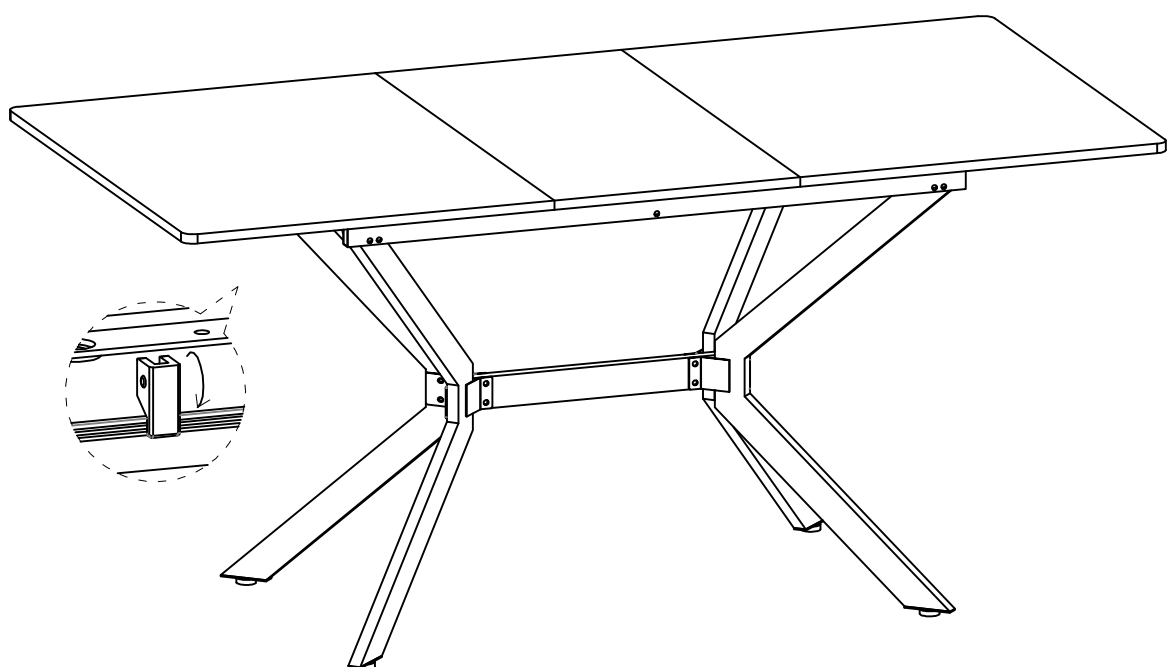

Step 13
Schritt 13

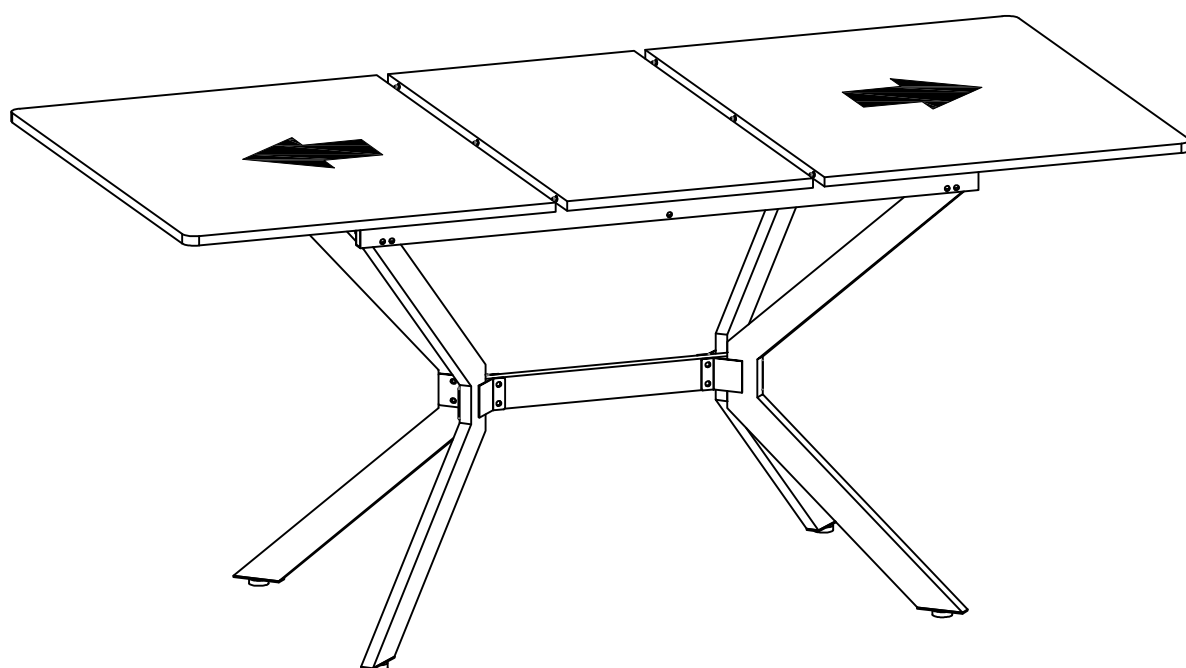
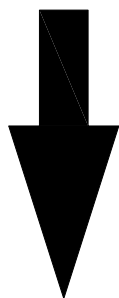
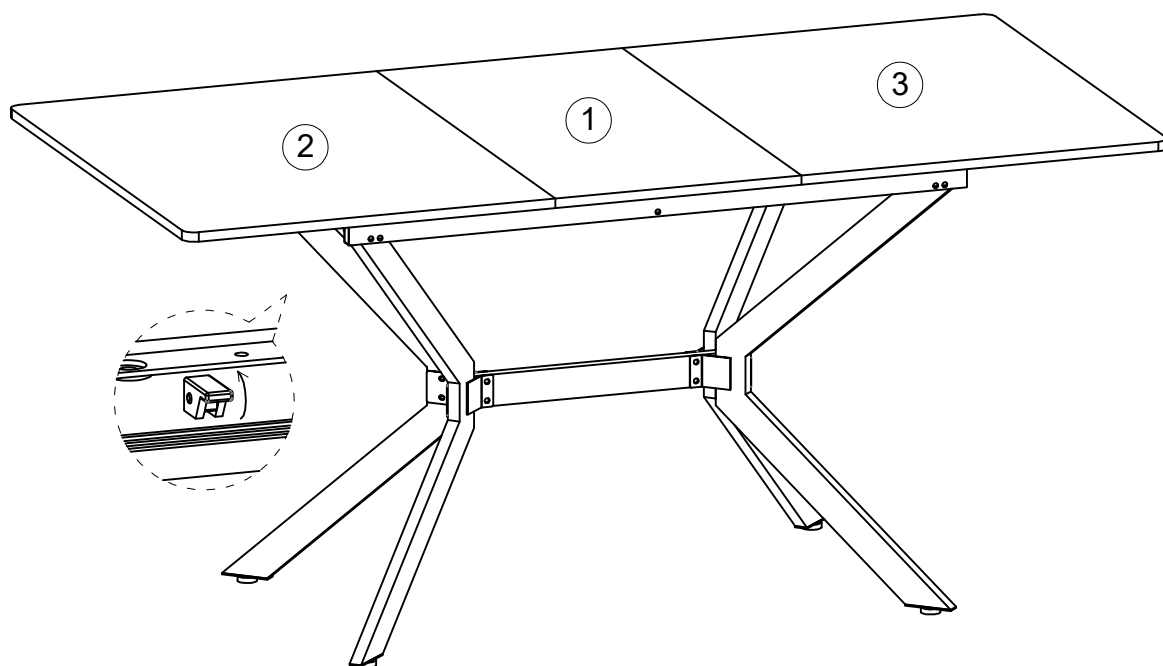

Step 14
Schritt 14

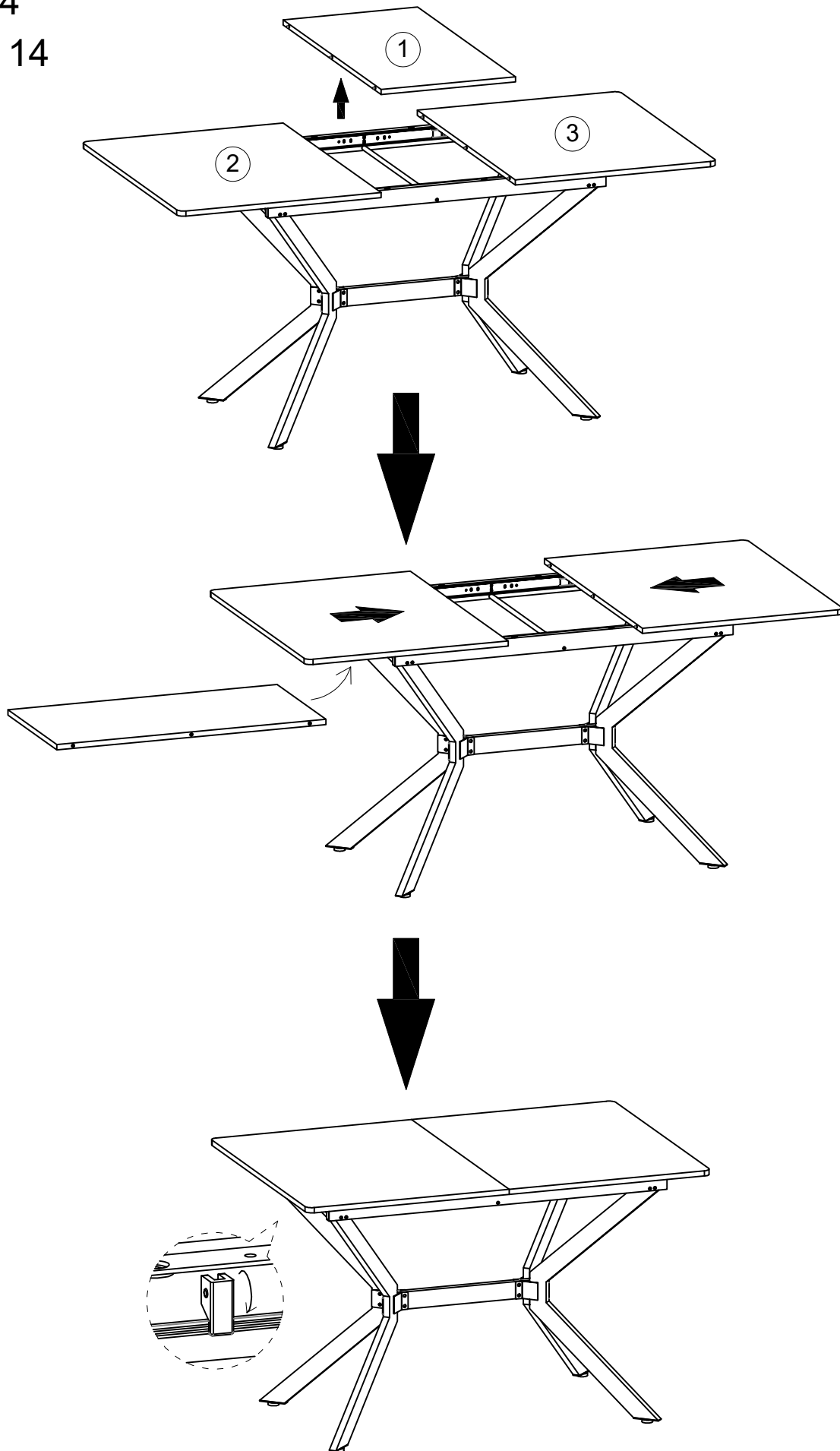

Step 15
Schritt 15

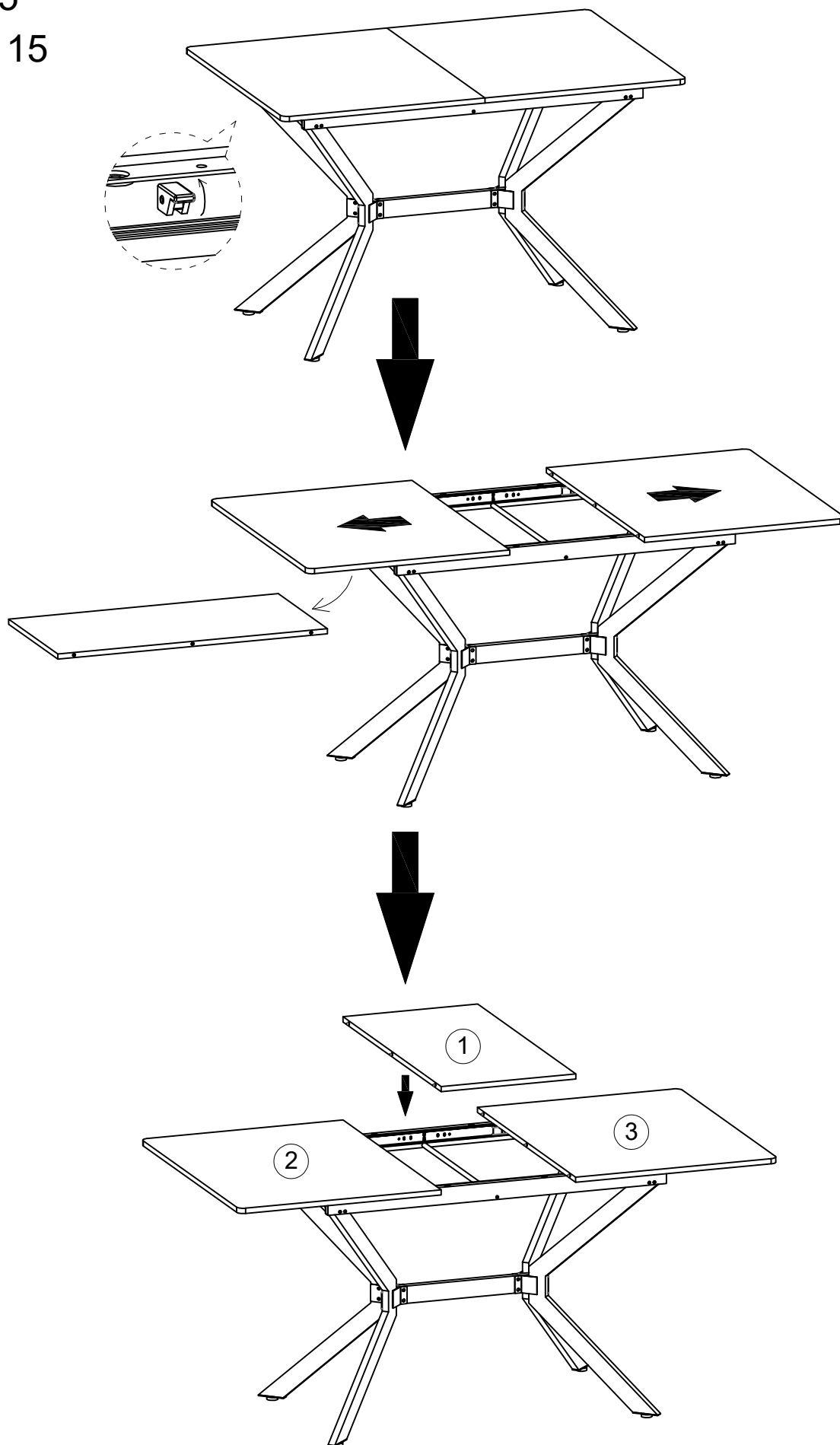

Step 16
Schritt 16

