

N625P307352W/N625P307353W

N625P307352S/N625P307353S

Product manual

Gebrauchsanweisung

Manuel du produit

Manual del producto

Manuale del prodotto

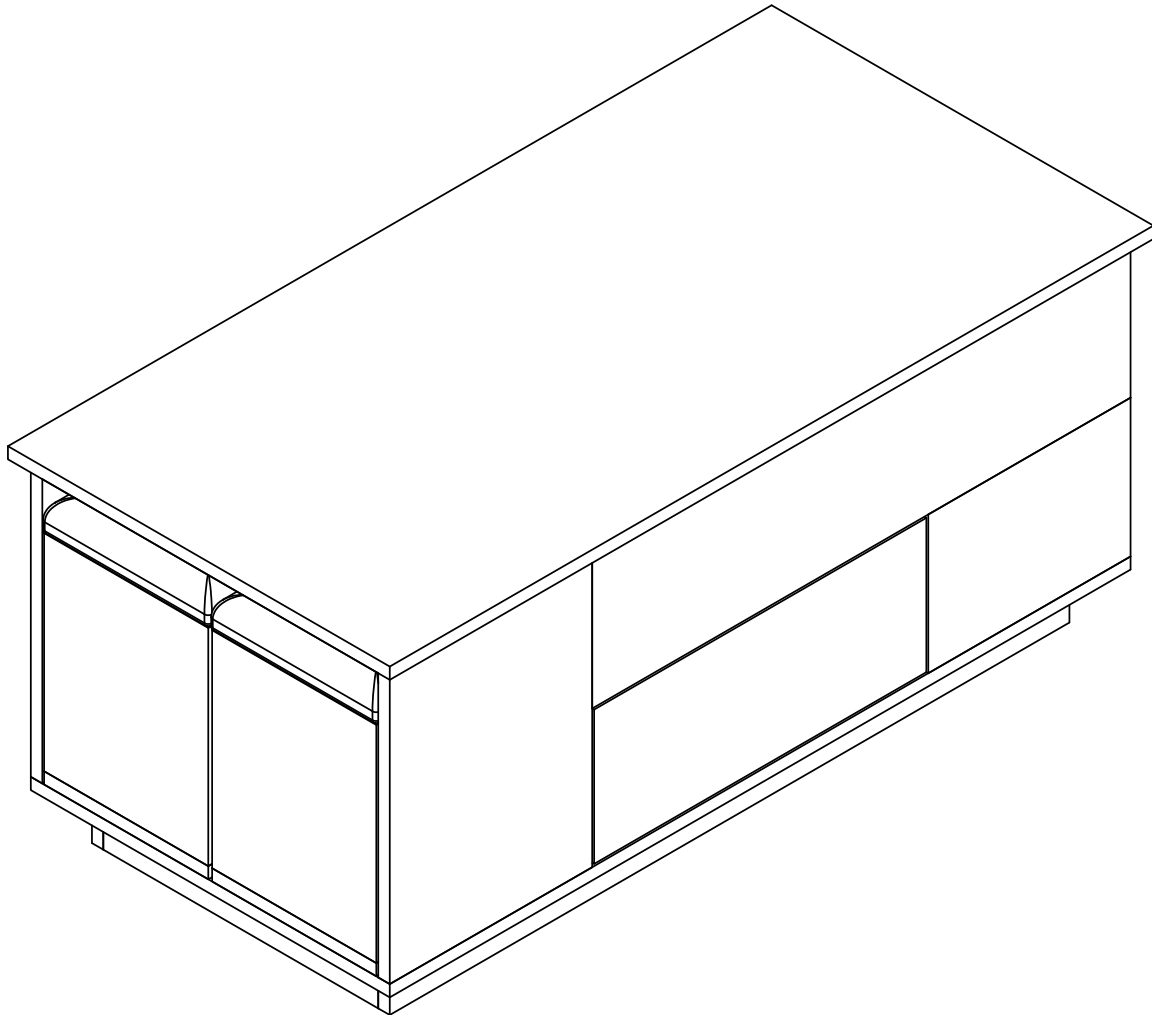

EN:Our product will be delivered to you in 2 packages.The delivery times of these 2 packages may differ,please be patient and thank you for your understanding

FR:Notre produit vous sera livré en 2 colis.Les delais de livraison de ces 2 colis peuvent différer, soyez patient et merci de votre compréhension.

DE:Unser Produkt wird Ihnen in 2 Paketen geliefert.Die Lieferzeiten dieser 2 Paketekönnenabweichen,bitte haben Sie etwas Geduld und vielen Dank für Ihr Verständnis

IT:I nostri prodotti vengono trasportati in due pacchetti. I tempi di consegna dei due pacchetti sono diversi abbiate pazienza e vi ringrazio per la vostra comprensione.

ES:Nuestro producto se entrega en dos paquetes. El tiempo de entrega de estos dos paquetes es diferente. Por favor sea paciente. Gracias por su comprensión.



2PERS



45 MIN

Tool Required Not Provided

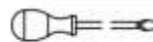

①

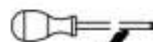

⊕





[DE]

Warnung: Lesen Sie diese Anleitung vor dem Zusammenbau bitte vollständig durch. Überprüfen Sie, ob Sie alle auf den Seiten aufgeführten Komponenten und Werkzeuge haben. Bewahren Sie die Anleitung zum späteren Nachschlagen auf. Teile des Zusammenbaus lassen sich mit 2 Personen leichter durchführen. Suchen Sie bei Bedarf professionelle Hilfe.

Warnung: Legen Sie alle Teile auf eine ebene Fläche. Legen Sie eine weiche Decke oder Ähnliches darunter, um sie vor Kratzern oder Flecken zu schützen. Vermeiden Sie es, Komponenten über den Boden zu ziehen oder zu schieben.

Warnung: Überprüfen Sie regelmäßig alle Beschläge und Befestigungen, um sicherzustellen, dass sie sicher sind und um Unfälle zu vermeiden. Wenn Teile fehlen, kaputt, beschädigt oder abgenutzt sind, verwenden Sie das Produkt nicht weiter, bis es mit vom Hersteller autorisierten Teilen repariert wurde.

Warnung: Lassen Sie Kinder nicht auf die Möbel klettern, da dies zum Umkippen und zu schweren Verletzungen führen kann. Bauen Sie die Möbel außerhalb der Reichweite von Kindern zusammen.

Warnung: Stellen Sie die Möbel nicht in die Nähe von Feuerquellen oder heißen Gegenständen, um Brandgefahr zu vermeiden.

Warnung: Reinigen Sie die Möbel mit einem feuchten Tuch oder Alkohol. Verwenden Sie keine Reinigungsmittel mit ätzenden Chemikalien.

[EN]

Warning: Please read these instructions fully before starting assembly. Check you have all the components and tools listed on pages. Keep the instructions for later reference. Parts of the assembly will be easier with 2 people. Seek professional assistance if necessary.

Warning: Please place all parts on a flat surface. Place a soft blanket or similar underneath to protect against scratches or stains. Avoid dragging or sliding components across the floor.

Warning: Regularly check all fittings and fastenings to ensure they are secure and to prevent accidents. If any parts are missing, broken, damaged, or worn, discontinue use of the product until repairs have been made using factory authorized parts.

Warning: Do not allow children to climb on the furniture as this may result in tipping and serious personal injury. Assemble the furniture away from the reach of children.

Warning: Do not place furniture close to fire sources or high-temperature objects to avoid the risk of fire. Do not place furniture in damp environments to prevent material damage.

Warning: Clean furniture with a damp cloth or alcohol, avoid using cleaning agents containing corrosive chemicals.

[FR]

Avertissement : Veuillez lire attentivement ces instructions avant de commencer l'assemblage. Vérifiez que vous disposez de tous les composants et outils répertoriés sur les pages. Conservez les instructions pour référence ultérieure. Certaines parties de l'assemblage seront plus faciles à 2 personnes. Demandez l'aide d'un professionnel si nécessaire.

Avertissement : Veuillez placer toutes les pièces sur une surface plane. Placez une couverture douce ou similaire en dessous pour les protéger des rayures ou des taches. Évitez de faire glisser les composants sur le sol.

Avertissement : Vérifiez régulièrement tous les raccords et fixations pour vous assurer qu'ils sont bien fixés et pour éviter les accidents. Si des pièces manquent, sont cassées, endommagées ou usées, cessez d'utiliser le produit jusqu'à ce que des réparations aient été effectuées à l'aide de pièces autorisées par l'usine.

Avertissement : Ne laissez pas les enfants grimper sur les meubles car cela pourrait entraîner un basculement et des blessures graves. Assemblez les meubles hors de portée des enfants.

Avertissement : Ne placez pas les meubles à proximité de sources de feu ou d'objets à haute température pour éviter tout risque d'incendie.

Avertissement : Nettoyez les meubles avec un chiffon humide ou de l'alcool, évitez d'utiliser des produits de nettoyage contenant des produits chimiques corrosifs.

[IT]

Attenzione: leggere attentamente queste istruzioni prima di iniziare il montaggio. Verificare di avere tutti i componenti e gli strumenti elencati nelle pagine. Conservare le istruzioni per riferimento futuro. Alcune parti del montaggio saranno più facili con 2 persone. Se necessario, chiedere assistenza professionale.

Attenzione: posizionare tutte le parti su una superficie piana. Posizionare una coperta morbida o simile sotto per proteggere da graffi o macchie. Evitare di trascinare o far scivolare i componenti sul pavimento.

Attenzione: controllare regolarmente tutti i raccordi e i dispositivi di fissaggio per assicurarsi che siano sicuri e per prevenire incidenti. Se alcune parti sono mancanti, rotte, danneggiate o usurate, interrompere l'uso del prodotto fino a quando non siano state eseguite le riparazioni utilizzando parti autorizzate dalla fabbrica.

Attenzione: non consentire ai bambini di arrampicarsi sui mobili poiché ciò potrebbe causare ribaltamenti e gravi lesioni personali. Montare i mobili lontano dalla portata dei bambini.

Attenzione: non posizionare i mobili vicino a fonti di fuoco o oggetti ad alta temperatura per evitare il rischio di incendio

Attenzione: pulire i mobili con un panno umido o alcol, evitare di utilizzare detersivi contenenti sostanze chimiche corrosive.

[ES]

Advertencia: Lea estas instrucciones completamente antes de comenzar el montaje. Compruebe que tiene todos los componentes y herramientas que se enumeran en las páginas. Conserve las instrucciones para consultarlas más adelante. El montaje de algunas partes será más sencillo con 2 personas. Busque ayuda profesional si es necesario.

Advertencia: Coloque todas las piezas sobre una superficie plana. Coloque una manta suave o algo similar debajo para protegerlas de rayones o manchas. Evite arrastrar o deslizar los componentes por el piso.

Advertencia: Verifique regularmente todos los accesorios y fijaciones para asegurarse de que estén seguros y evitar accidentes. Si falta alguna pieza, está rota, dañada o desgastada, deje de usar el producto hasta que se hayan realizado las reparaciones con piezas autorizadas de fábrica.



Advertencia: No permita que los niños se suban a los muebles, ya que esto puede provocar que se vuelquen y lesiones personales graves. Monte los muebles fuera del alcance de los niños.

Advertencia: No coloque los muebles cerca de fuentes de fuego u objetos de alta temperatura para evitar el riesgo de incendio.

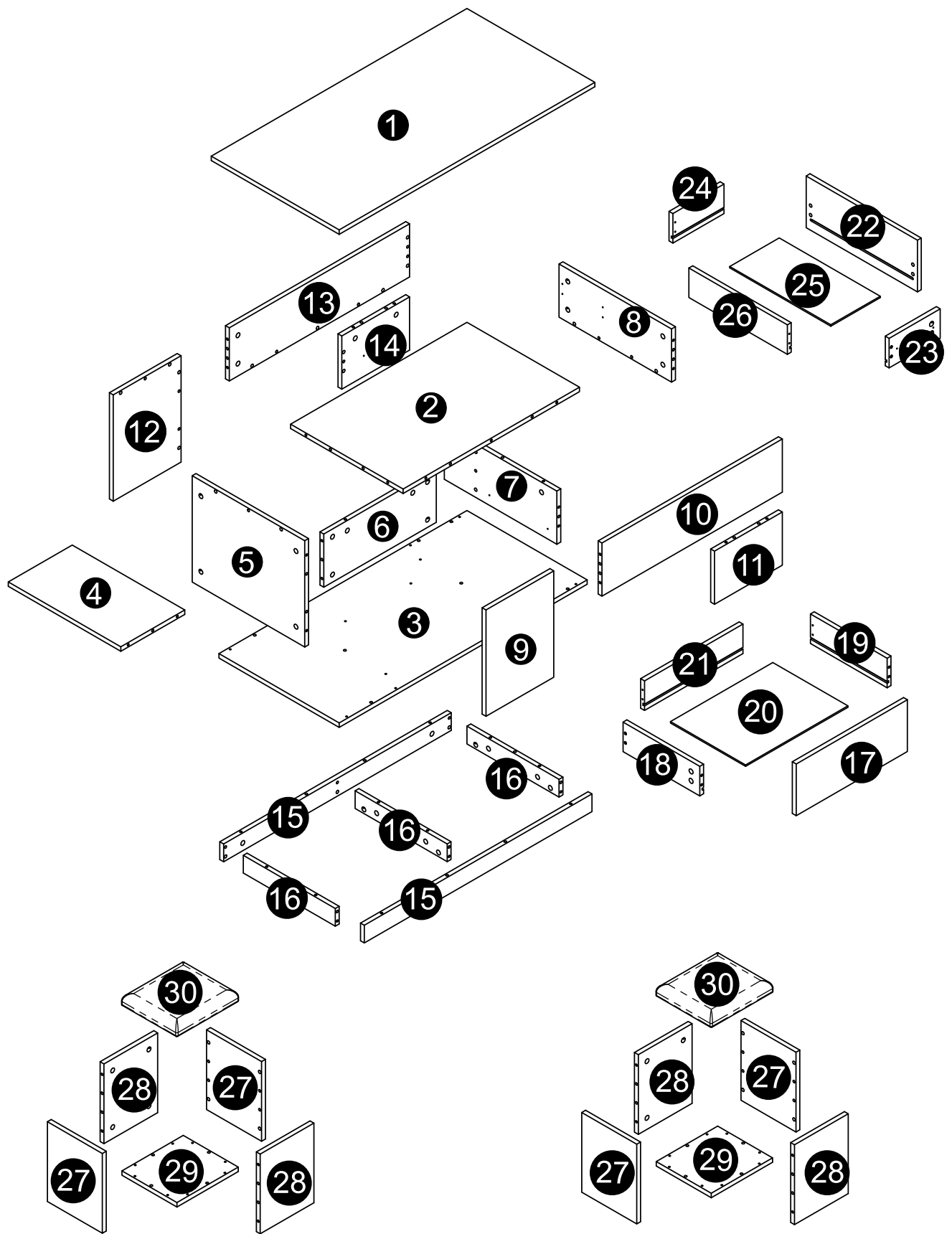

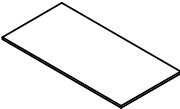
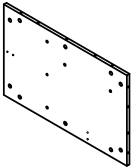
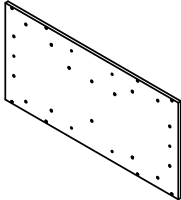
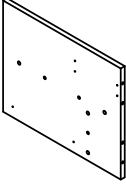
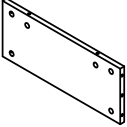
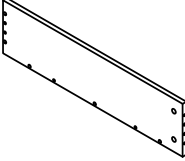

Advertencia: Limpie los muebles con un paño húmedo o alcohol, evite usar agentes de limpieza que contengan químicos corrosivos.

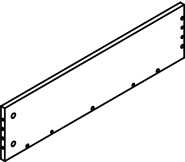
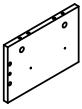
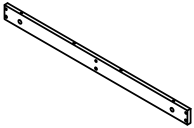
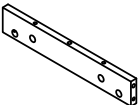



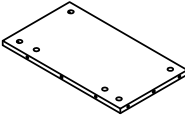
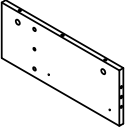
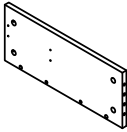

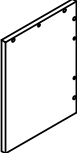
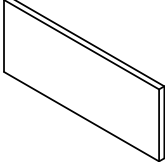
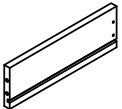
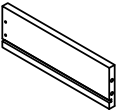
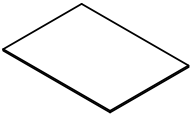
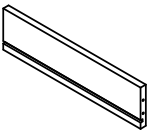
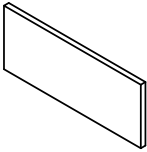

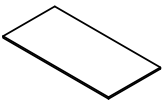
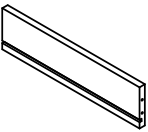
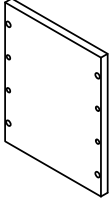
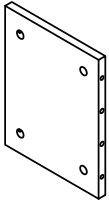
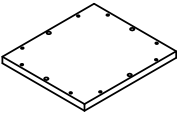
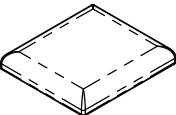

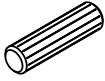
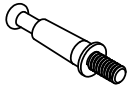

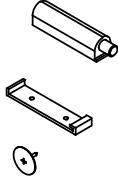
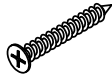
DE:Teilleiste für / EN:Parts List for / FR:Liste des pièces pour / IT:Elenco delle parti per /ES:Lista de piezas para
N625P307352W/N625P307352S

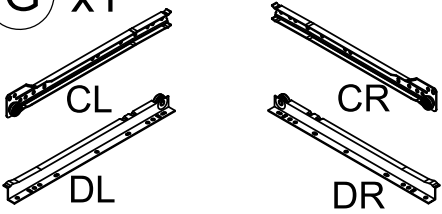
						
① x1	② x1	③ x1	⑤ x1	⑥ x1	⑩ x1	⑪ x1
						
⑬ x1	⑭ x1	⑮ x2	⑯ x3			

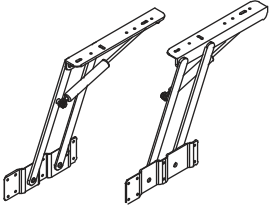
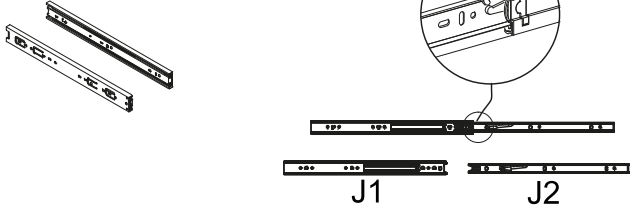
DE:Teilleiste für / EN:Parts List for / FR:Liste des pièces pour / IT:Elenco delle parti per /ES:Lista de piezas para
N625P307353W/N625P307353S

						
④ x1	⑦ x1	⑧ x1	⑨ x1	⑫ x1	⑰ x1	⑱ x1
						
⑲ x1	⑳ x1	㉑ x1	㉒ x1	㉓ x1	㉔ x1	㉕ x1
						
⑳ x1	㉗ x4	㉘ x4	㉙ x2	㉚ x2		

<p>A x77</p> 	<p>B x84</p> 	<p>C x84</p> 	<p>D x 2</p> 	<p>E x22</p> 	<p>F x44</p> 
<p>φ8*40</p>				<p>φ3.5*35</p>	<p>φ3.5*14</p>
<p>G x1</p> 	<p>H x18</p> 	<p>I x1</p>  <p>Left Side Linke Seite Côté Gauche Lado Izquierdo Lato Sinistro</p> <p>Right Side Rechte Seite Côté Droit Lado Derecho Lato Destro</p>			
<p>300mm</p>					
<p>J x1</p>  <p>J1 J2</p>			<p>K x70</p> 	<p>L x1</p> 	
<p>200mm</p>				<p>2800mm</p>	
<p>M x16</p> 					
<p>φ3.5*30</p>					

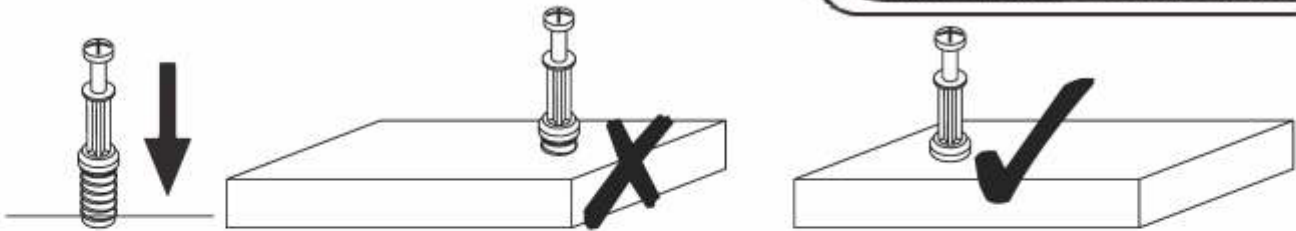

EN_QUICKFIT: Tighten quickfit until shoulder is flush with panel. Do not overtighten or undertighten.

FR_RACCORD RAPIDE: Faites serrer le raccord rapide jusqu'à ce que l'épaulement soit parfaitement encastré dans le panneau. Il ne faut ni trop serrer ni insuffisamment serrer.

ES_QUICKFIT: Apriete quickfit hasta que el hombro se descargue con el panel. NO lo sobreapriete ni lo apriete poco.

DE_QUICKFIT: Ziehen Sie den Quickfit fest, bis die Schulter mit der Platte bündig ist. Bitte nicht zu fest oder zu schwach anziehen.

IT_MONTAGGIO RAPIDO: Stringere il montaggio rapido fino a quando la spalla è a filo con il pannello, non stringere troppo o troppo poco.



EN_CAM LOCK: When fitting cam lock, ensure starting position is correct before you insert connecting quickfit.

FR_SERRURE BATTEUSE: Avant d'insérer la serrure batteuse, veillez à la bonne orientation avant d'insérer le raccord rapide.

ES_CIERRE DE LA CÁMARA: Cuando instale el cierre de la cámara, asegúrese de que la posición de inicio es correcta antes de que inserte el quickfit conector.

DE_CAM-LOCK: Achten Sie bei der Montage des Cam-Locks auf die richtige Ausgangsposition, bevor Sie den Quickfit einsetzen.

IT_BLOCCAGGIO A CAMMA: Quando si monta il bloccaggio a camma, assicurarsi che la posizione iniziale sia corretta prima di inserire il montaggio rapido di collegamento.

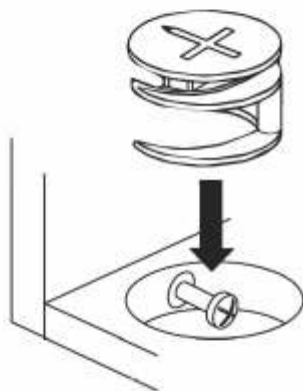

EN_Quickfit head should be in the centre of the cam lock when the two panels are joined.

Cam lock should be inserted before quickfit.

FR_Lorsque les deux panneaux sont assemblés, la tête du raccord rapide doit reposer au centre de la serrure batteuse. Il faut insérer la serrure batteuse avant le raccord rapide.

ES_El cabezal del quickfit debe estar en el centro del cierre de la cámara cuando se unan los dos paneles.

Se debe insertar el cierre de la cámara antes que el quickfit.

DE_Der Quickfit-Kopf sollte sich in der Mitte des Cam-Locks befinden, wenn die beiden Platten zusammengefügt sind.

Der Cam-Lock sollte vor dem Quickfit eingesetzt werden.

IT_La testa del montaggio rapido deve trovarsi al centro del bloccaggio a camma quando i due pannelli sono uniti.

Il Bloccaggio a Camma deve essere inserito prima del montaggio rapido.

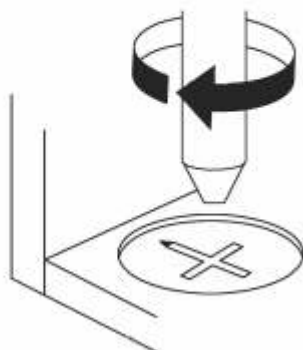

EN_Turn cam lock clockwise to tighten.

FR_Faites tourner la serrure batteuse dans le sens des aiguilles d'une montre pour la resserrer.

ES_Gire el cierre de la cámara en sentido horario para apretarlo.

DE_Drehen Sie den Cam-Lock im Uhrzeigersinn, um ihn festzuziehen.

IT_Ruotare il bloccaggio a camma in senso orario per stringere.

EN_NOTE: Pull inner and outer drawer runners apart before fixing them to panels.

FR_REMARQUE: Avant de fixer les glissières de tiroir aux panneaux, tirez vers l'extérieur et poussez vers l'intérieur de chacun des tiroirs.

ES_NOTA: retire los rieles interiores y exteriores antes de fijarlos a los paneles.

PT_NOTA: Separar as corredeças das gavetas interiores e exteriores antes de fixar para os painéis.

DE_HINWEIS: Ziehen Sie die inneren und äußeren Schubladenführung auseinander, bevor Sie sie an den Platten befestigen.

IT_NOTA: Separare le guide interne ed esterne del cassetto prima di fissarle ai pannelli.

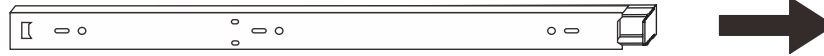

EN_Slide drawer runners apart until the drawer lock can be seen, as shown.

FR_Les glissières de tiroir doivent être ouvertes jusqu'à ce que la serrure du tiroir soit visible, comme indiqué.

ES_Deslice a un lado los rieles del cajón hasta que se pueda ver el cierre del armario, tal y como se muestra.

PT_Deslizam-se as gavetas até se poder ver o fecho da gaveta, como se mostra.

DE_Schieben Sie die Schubladenführungen auseinander, bis das Schubladenschloss sichtbar ist, gemäß der Abbildung.

IT_Far scorrere le guide del cassetto fino a quando non sia visibile il blocco di scorrimento, come mostrato.

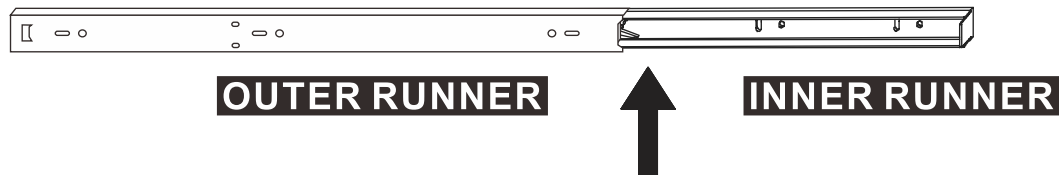

EN_Press and hold the drawer runner lock and then continue to slide drawer runners apart, as shown.

FR_En appuyant et en maintenant le verrouillage des glissières de tiroir, vous pouvez continuer à les écarter l'une de l'autre, comme indiqué.

ES_Mantenga presionado el cierre del riel del cajón y después continúe deslizando a un lado los rieles de los cajones, tal y como se muestra.

PT_Manter pressionado o fecho de gaveta e depois continuar a deslizar as corredeças da gaveta, como mostrado.

DE_Drücken und halten Sie die Verriegelung der Schubladenführung und schieben Sie die Schubladenführungen wie abgebildet weiter auseinander.

IT_Tenere premuto il blocco di scorrimento e quindi continuare a far scorrere la guida, come mostrato.

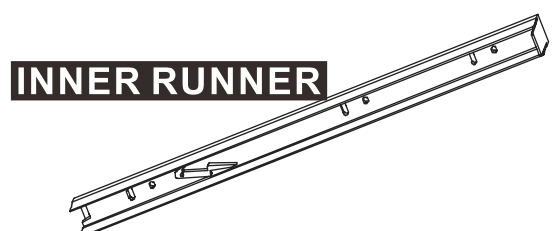
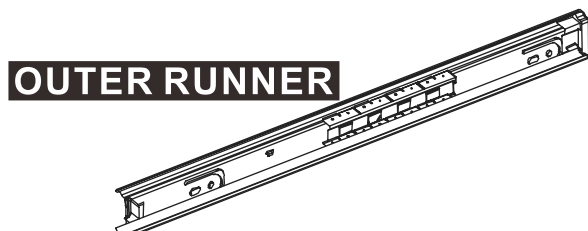
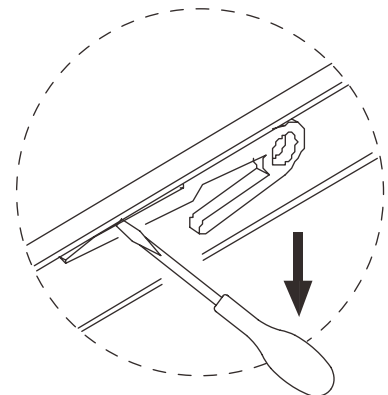

EN_Your inner and outer drawer runners are ready to be fixed to panels.

FR_Il est possible, à présent, de fixer les glissières intérieures et extérieures de vos tiroirs sur des panneaux.





ES_Los rieles interiores y exteriores del cajón están listos para fijarse a los paneles.

PT_As corredeças das gavetas interiores e exteriores estão prontas para serem fixadas nos painéis.

DE_Ihre inneren und äußeren Schubladenführungen sind bereit, an den Platten befestigt zu werden.



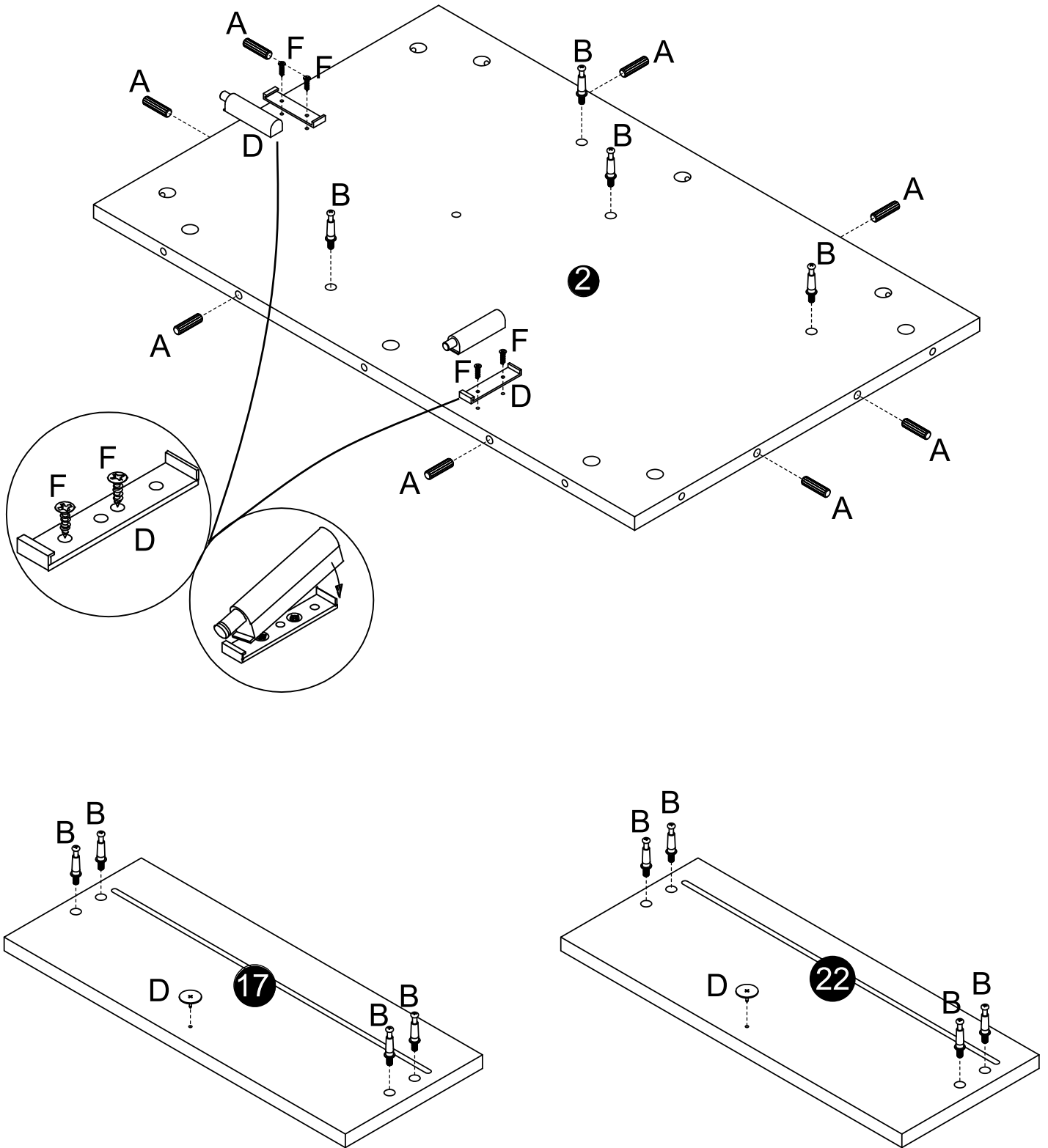

IT_Le guide interne ed esterne sono pronte per essere fissate ai pannelli.

01

Ax8	Bx12	Dx2	Fx4
			
$\phi 8 \times 40$			$\phi 3.5 \times 14$

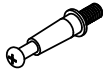

02

Ax9 	Bx8 	Fx4 	Gx1 CL 	Gx1 CR 
$\phi 8 \times 40$		$\phi 3.5 \times 14$		

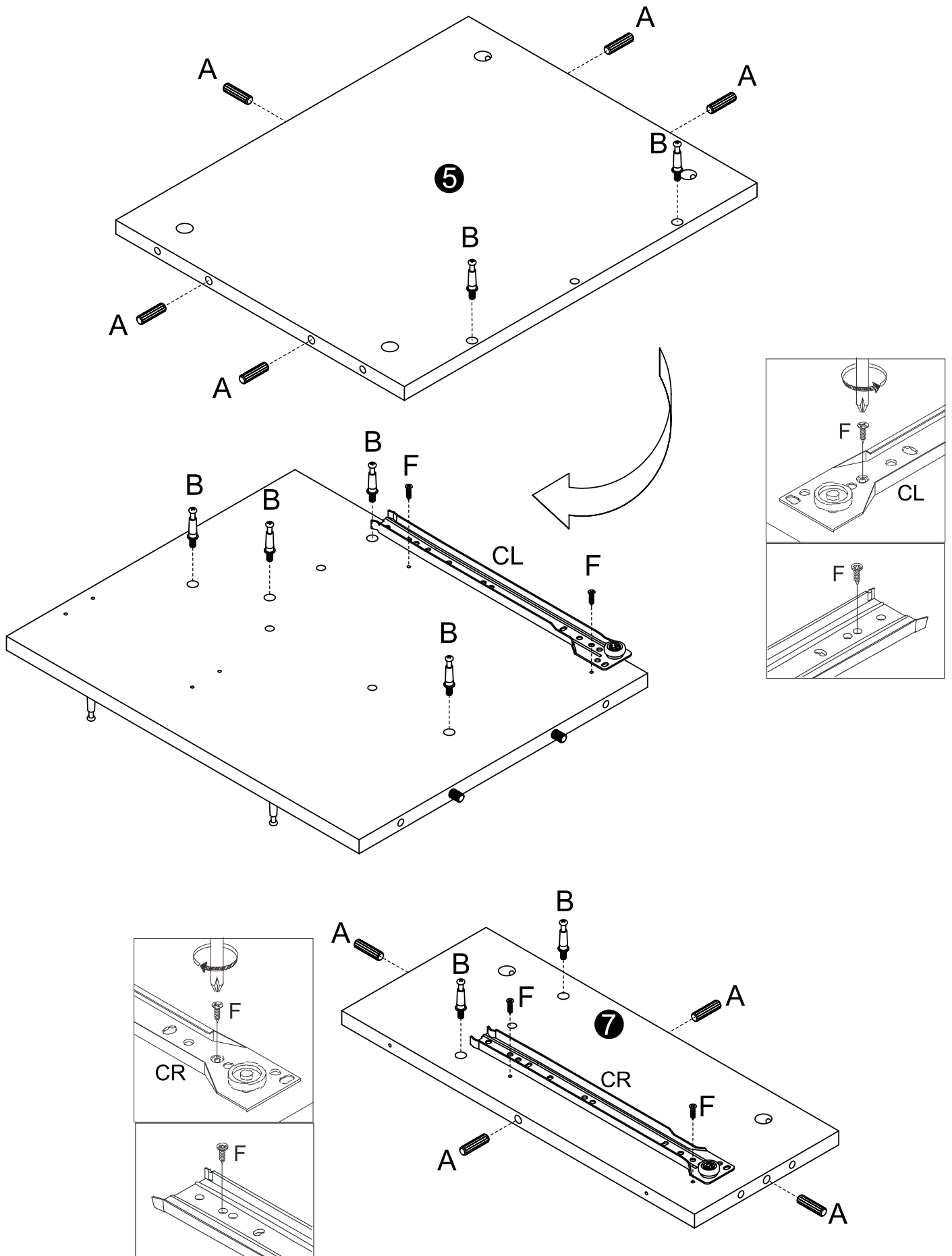

03

Ax5



Bx10

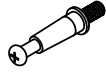

$\phi 8 \times 40$

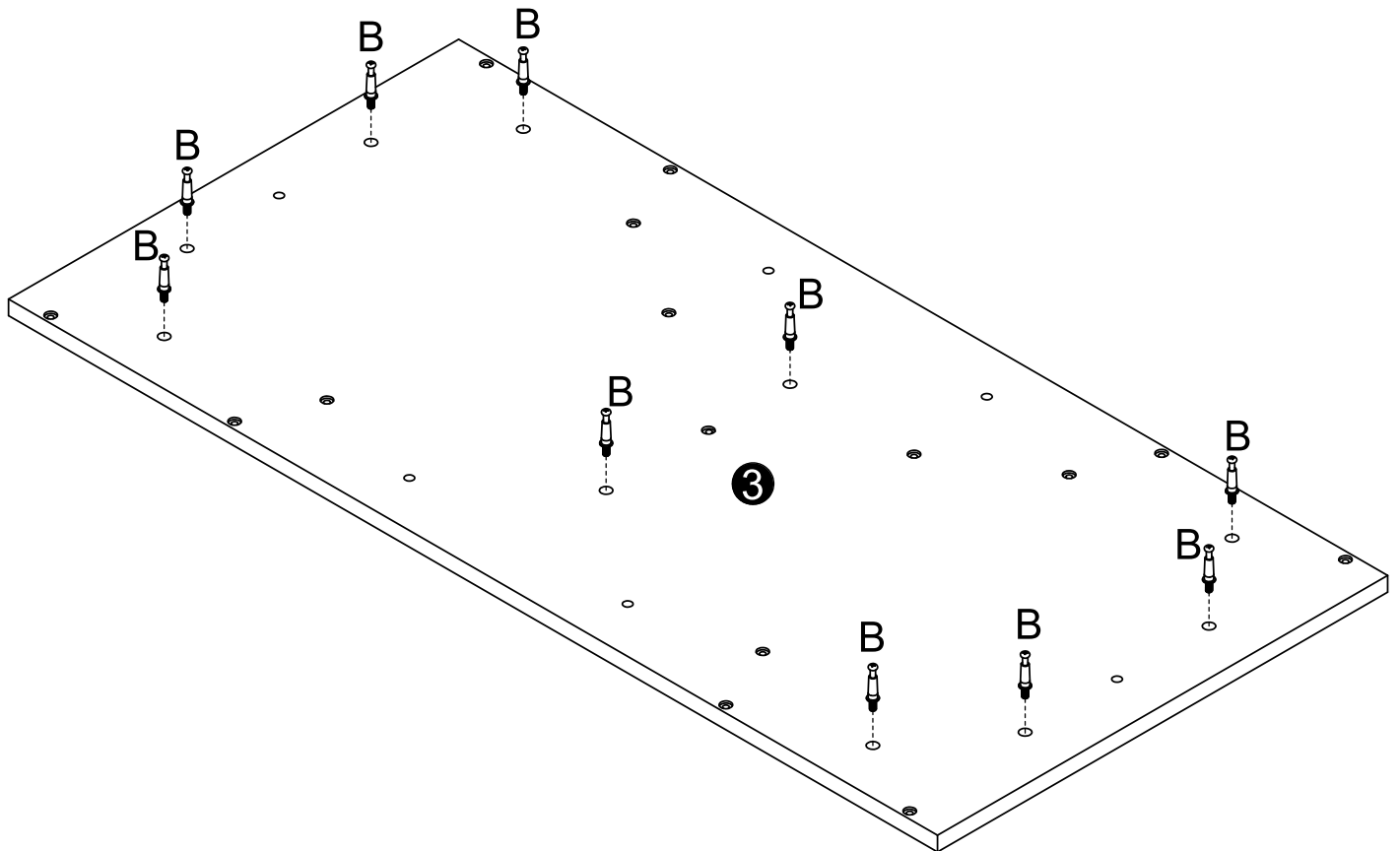
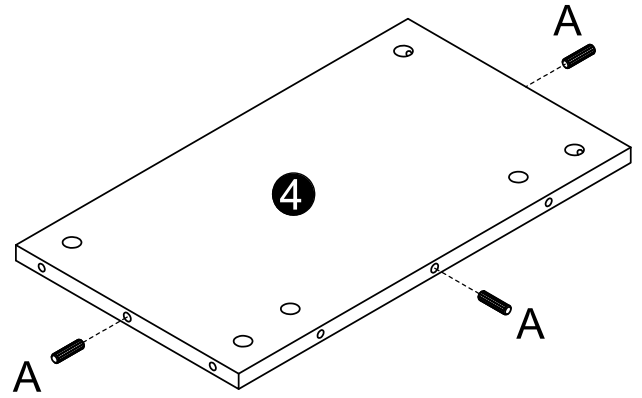
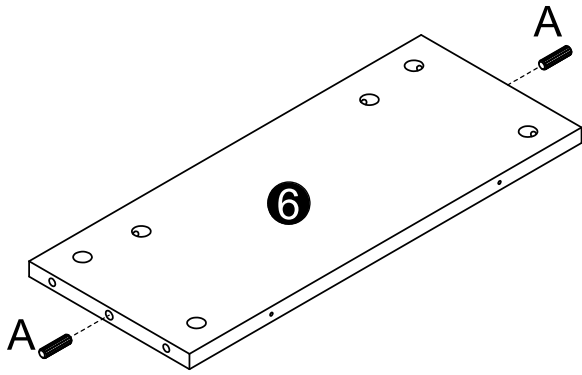

04

Ax2



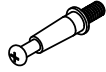

Bx12

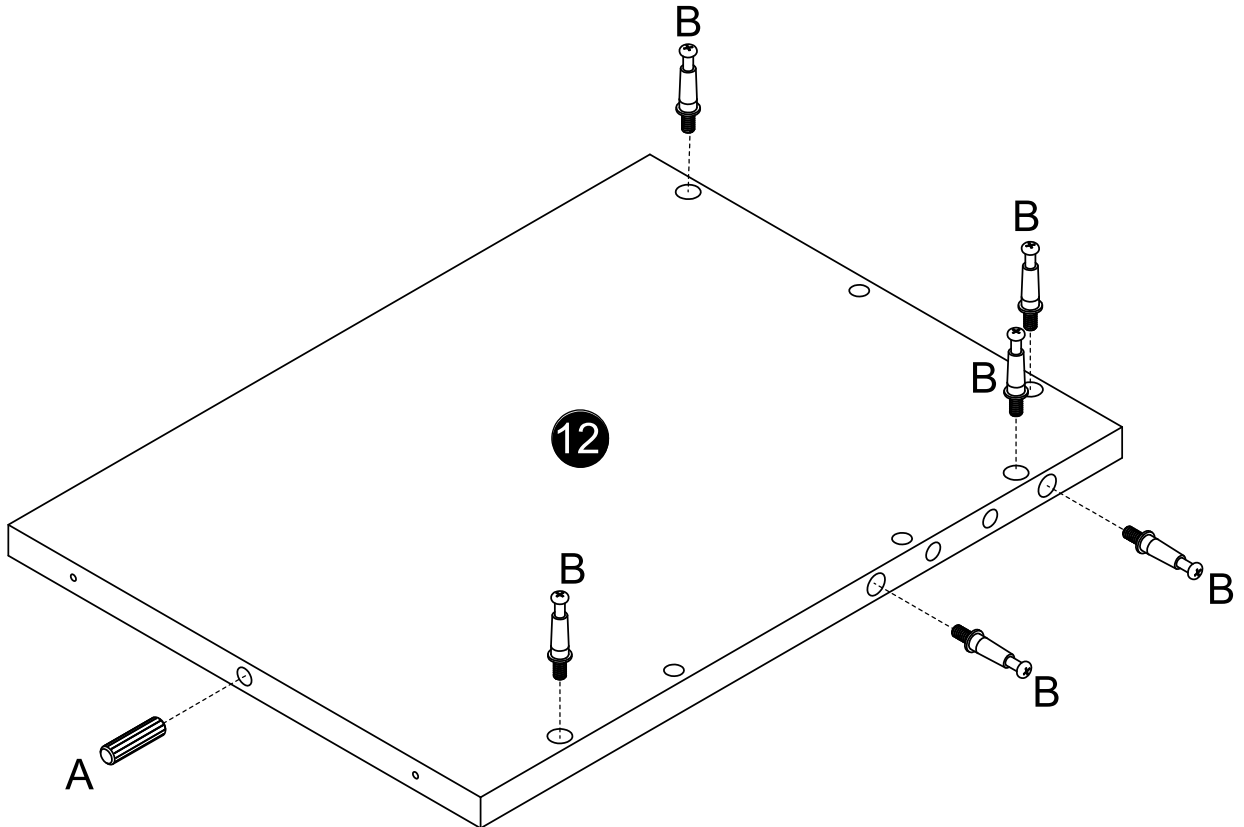
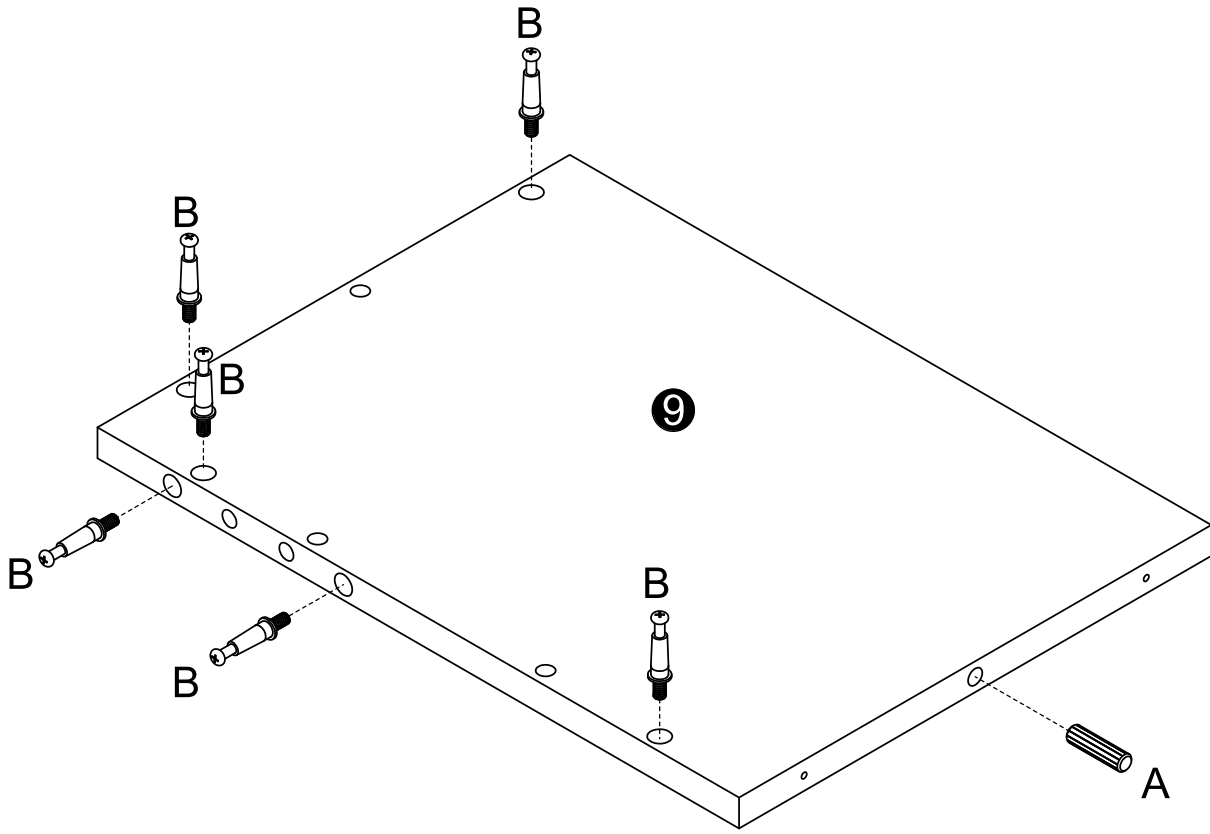

$\phi 8 \times 40$

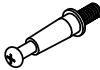

05

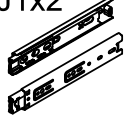
Ax8 	Bx4 	Fx4 	J1x2 
$\phi 8 \times 40$		$\phi 3.5 \times 14$	

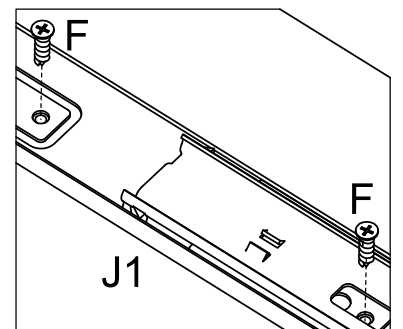
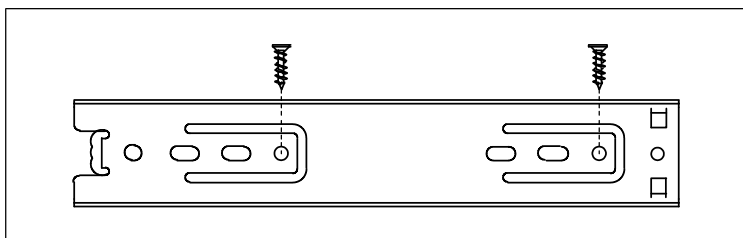
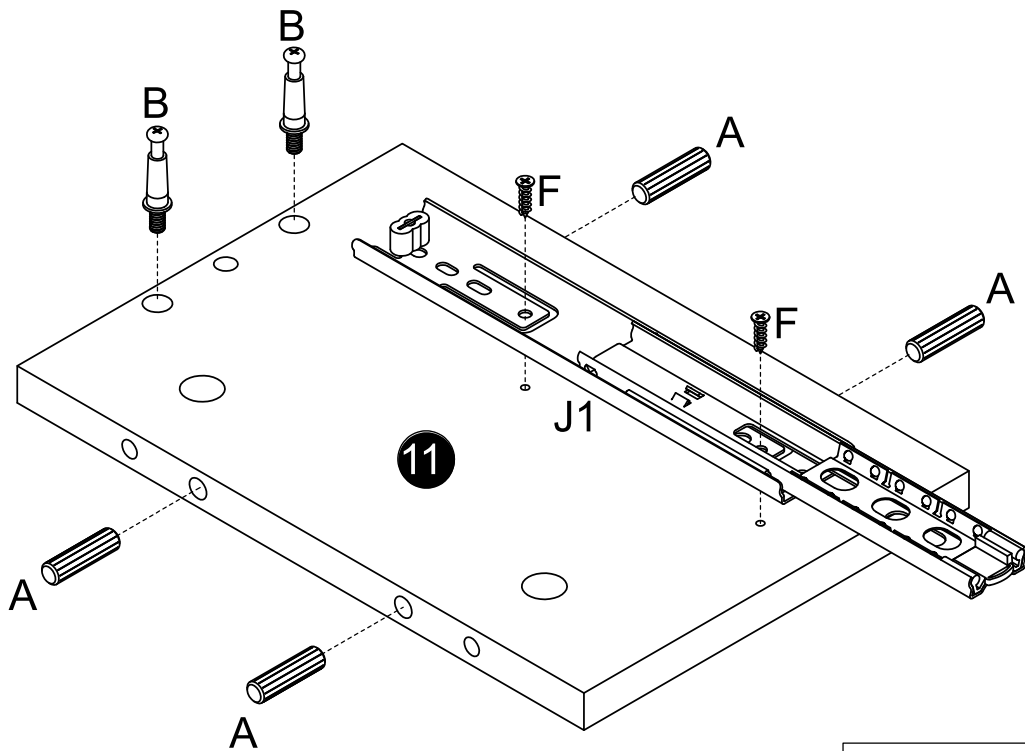
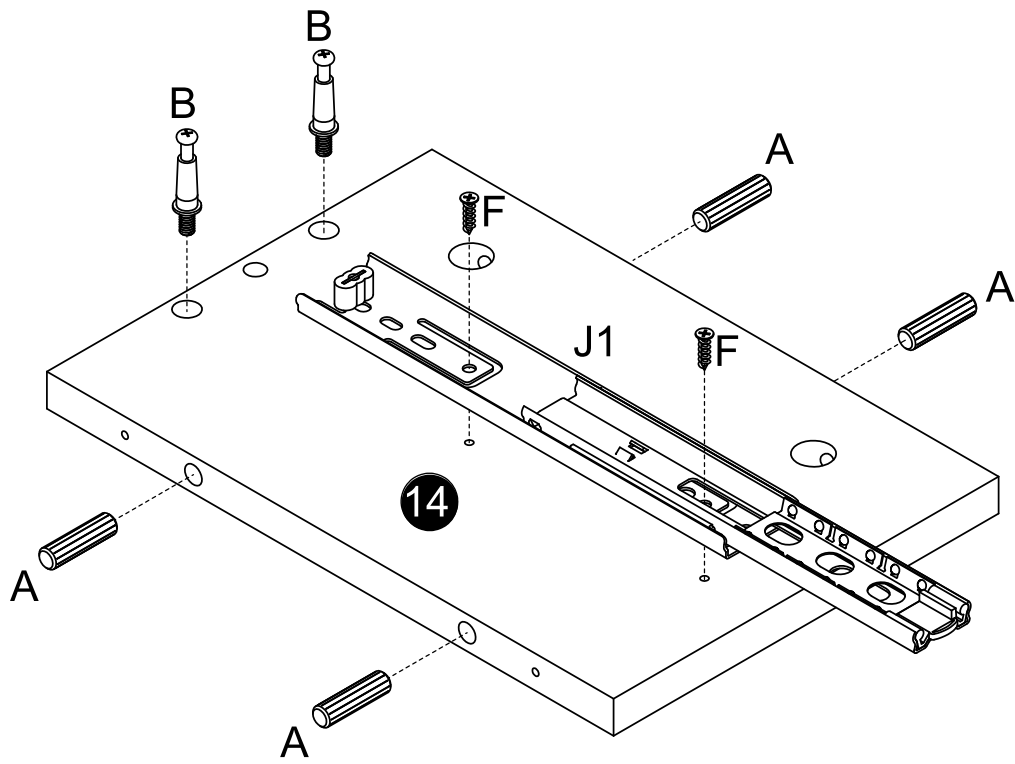

06

Ax17



Bx8



φ8*40

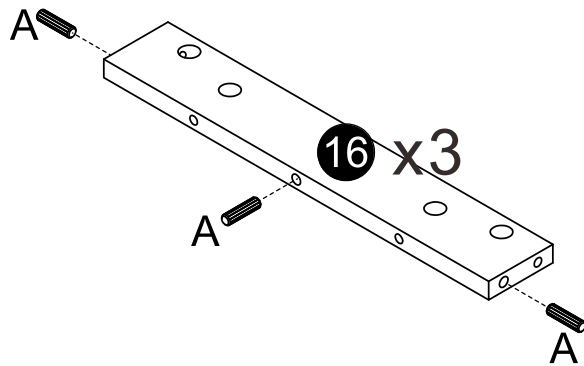
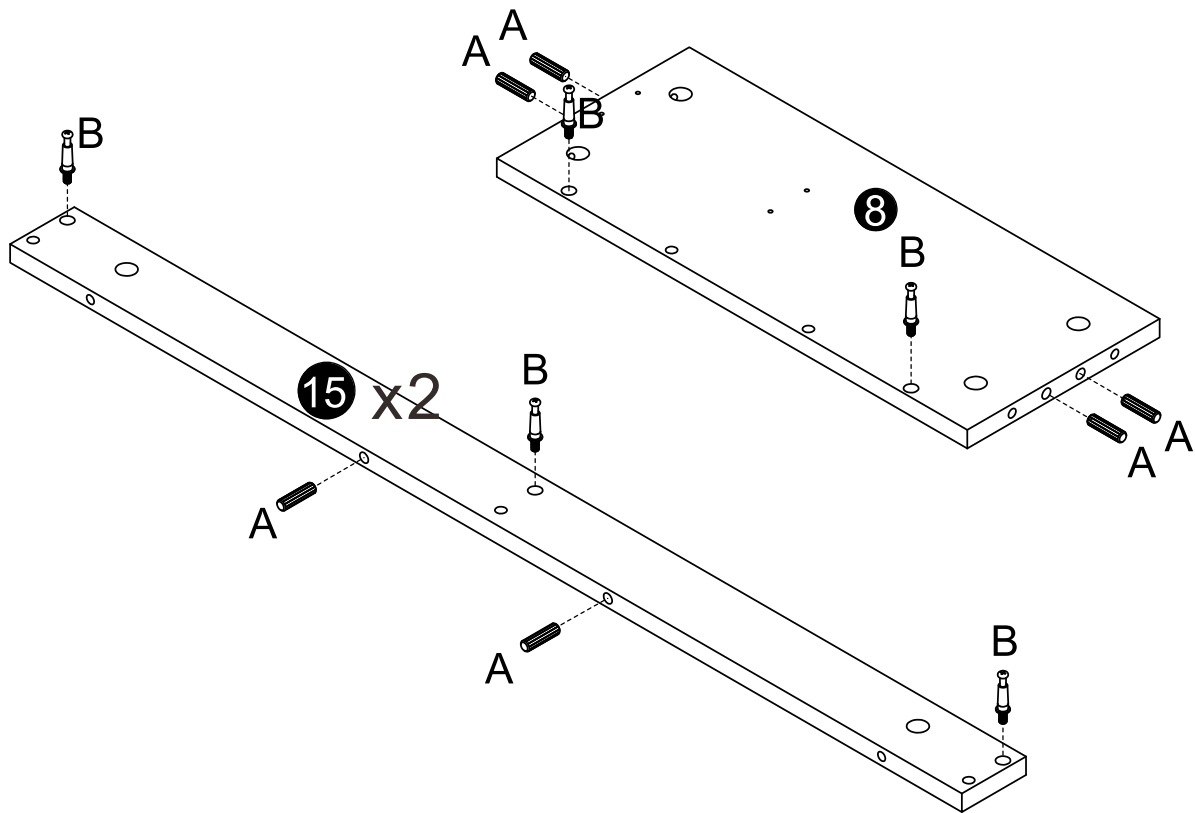

07

Ax4



Bx14

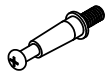

$\phi 8 \times 40$

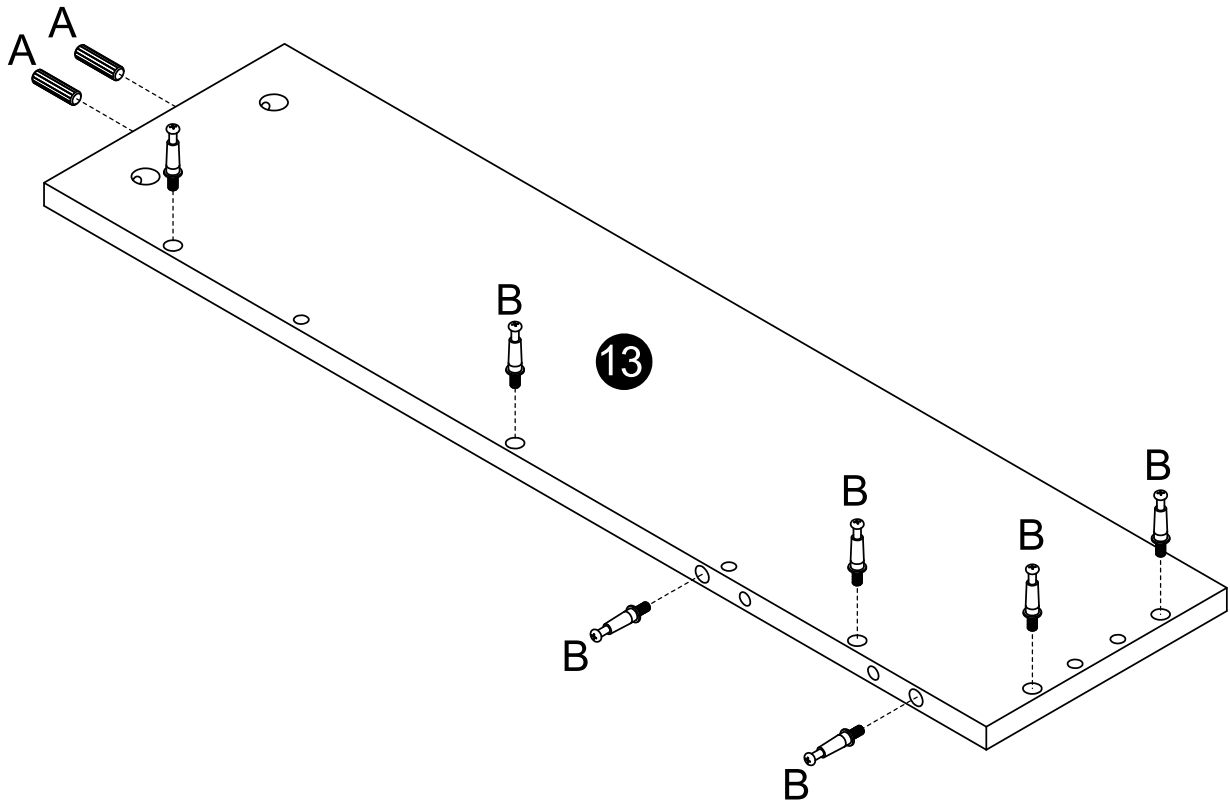
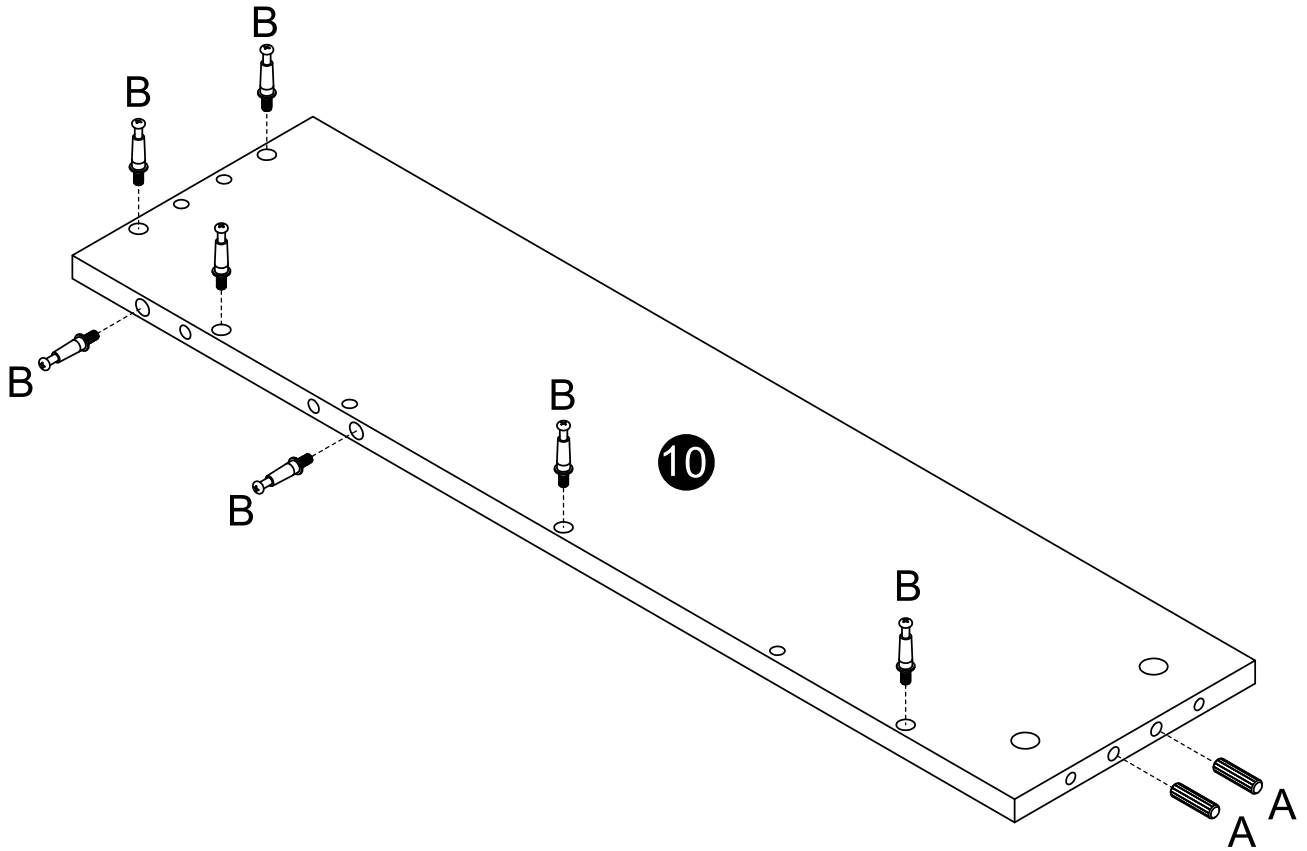

08

Cx4

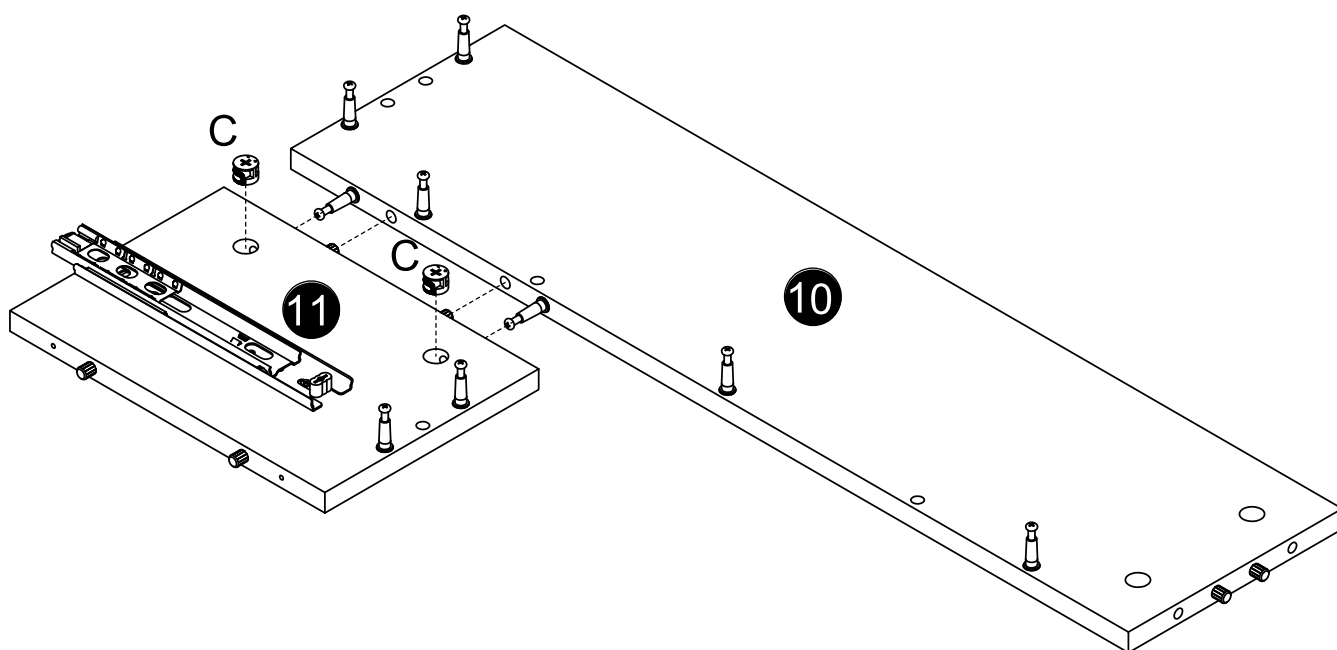
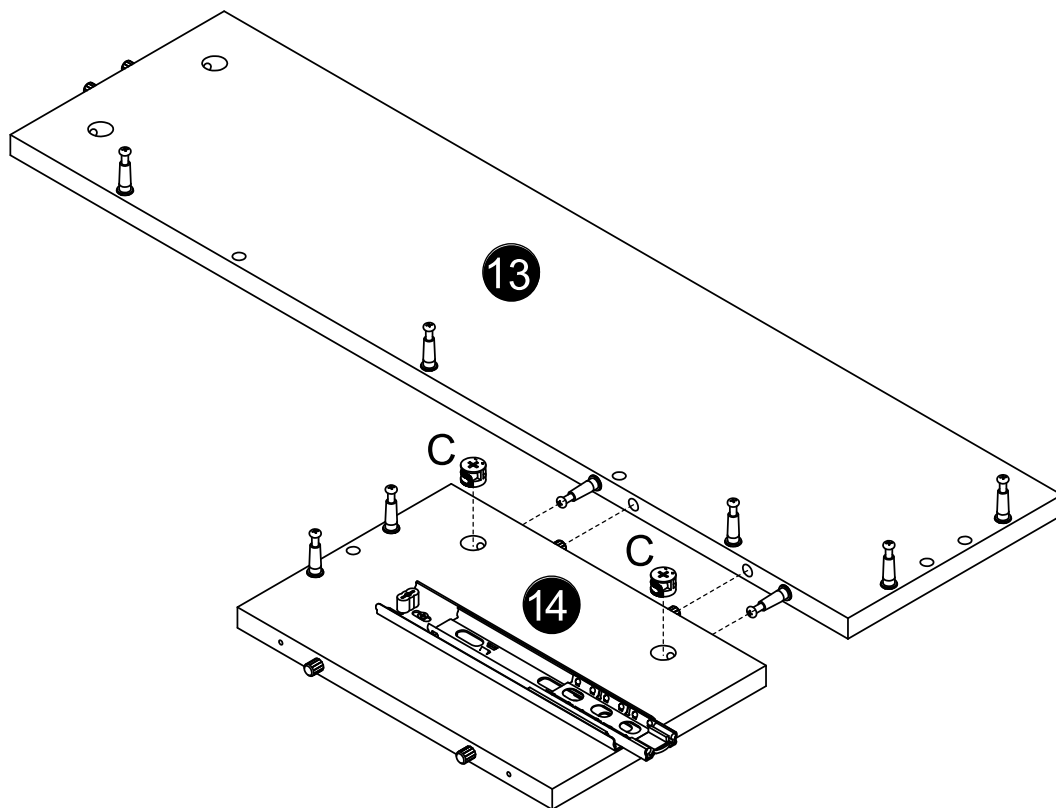

09

Cx4

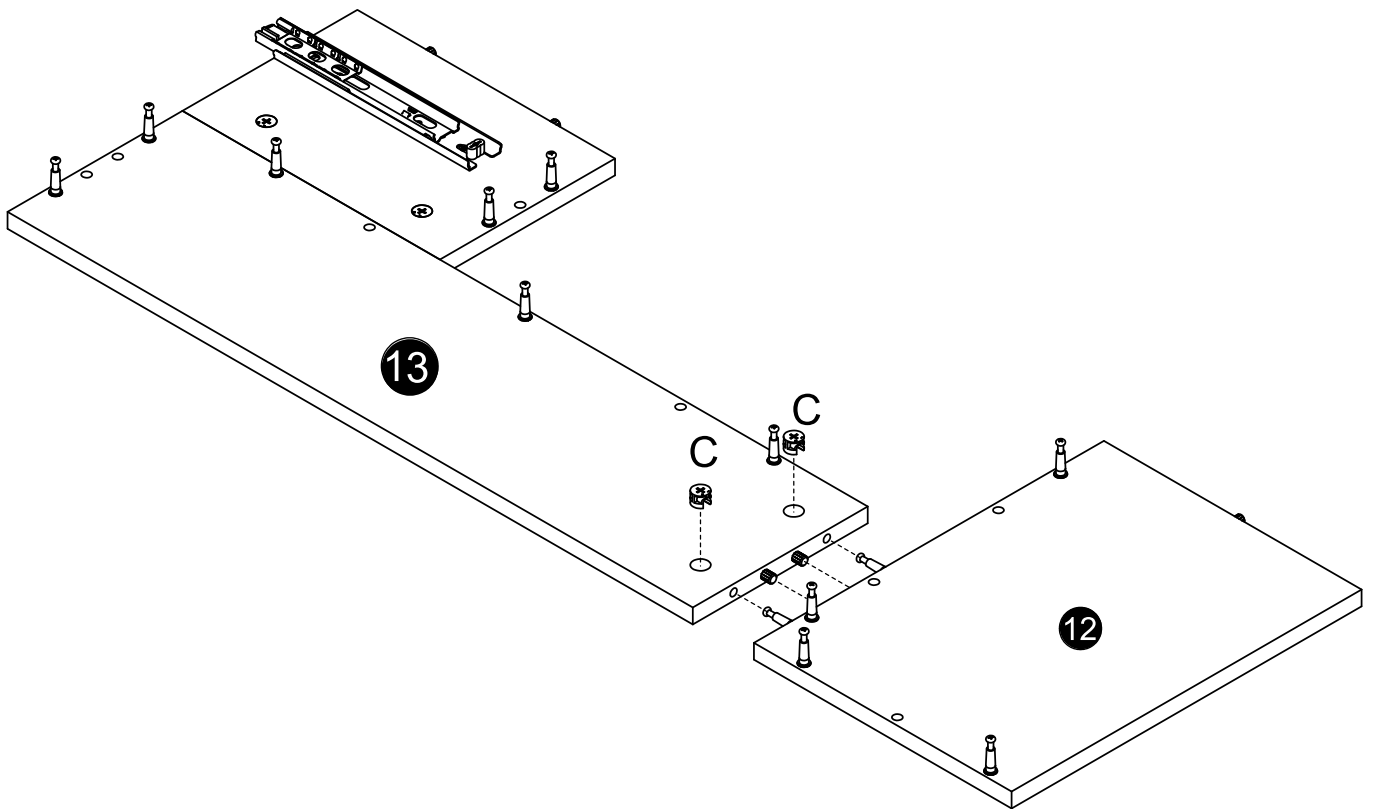
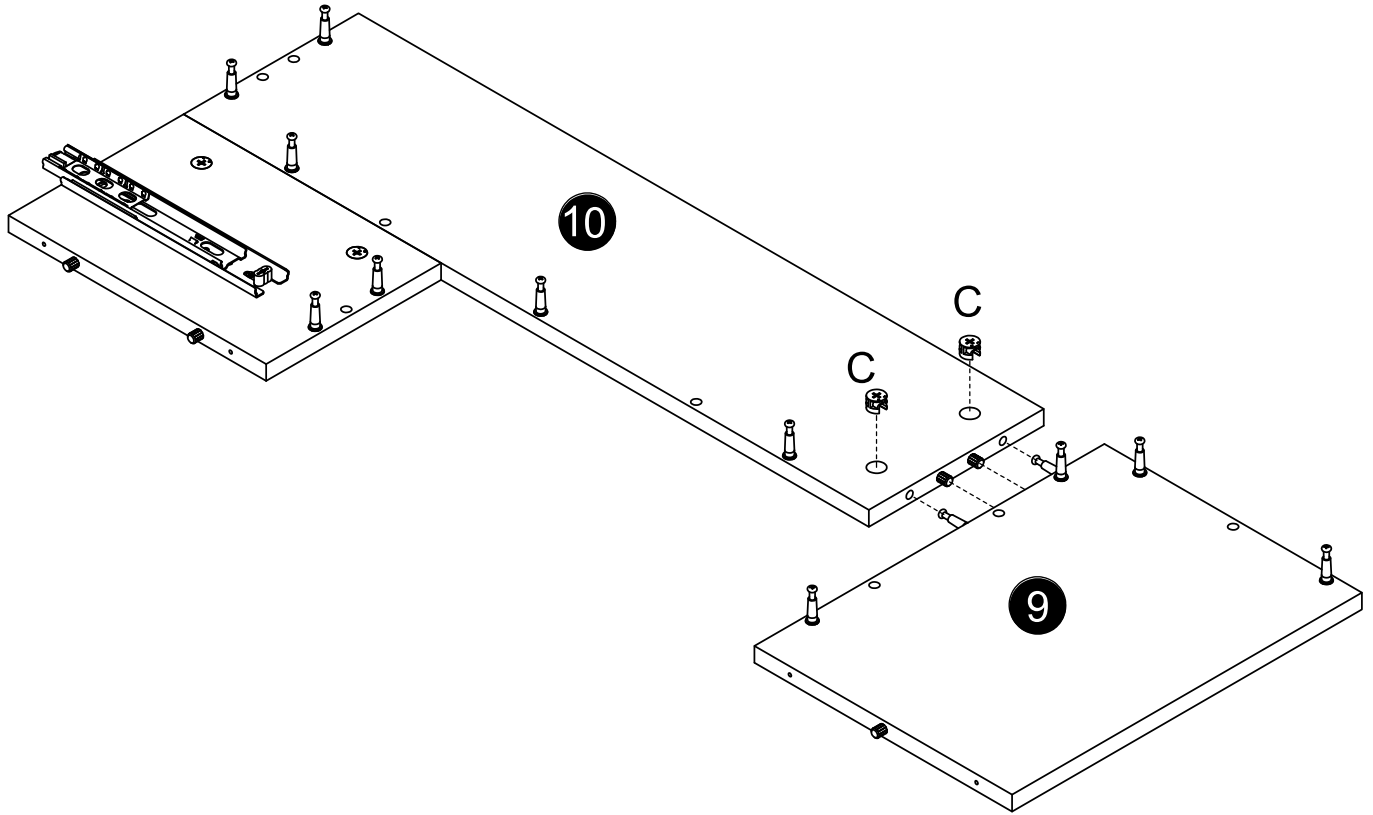

10

Cx2

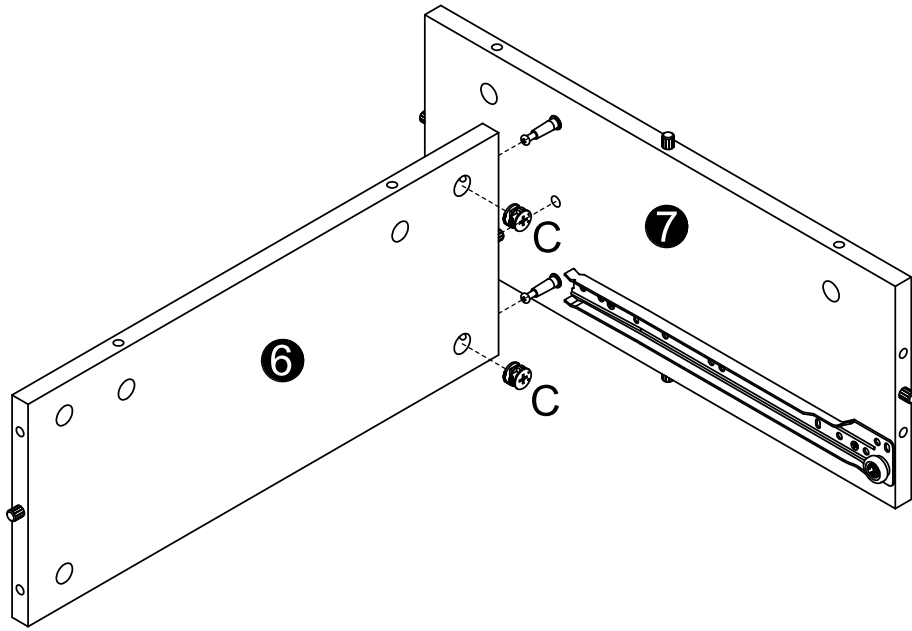
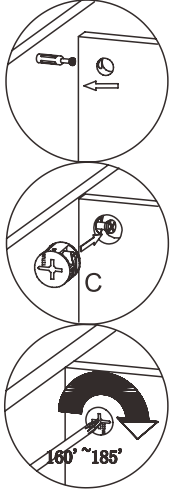

11

Cx2

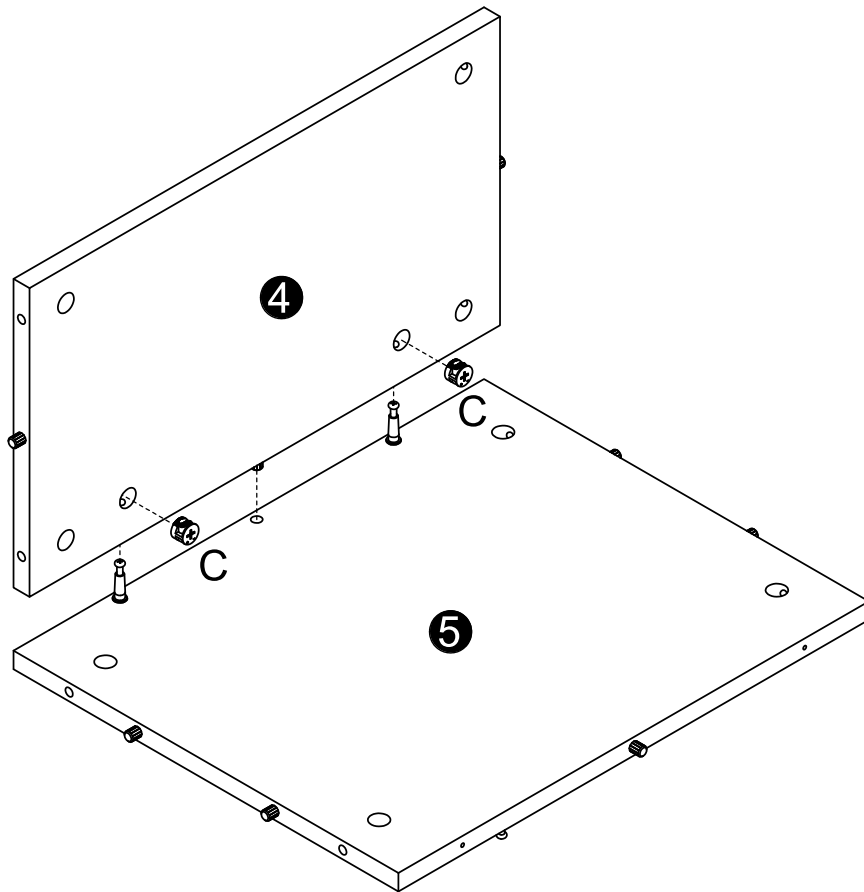
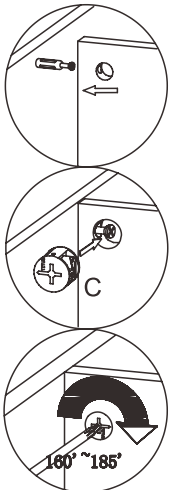

12

Cx4

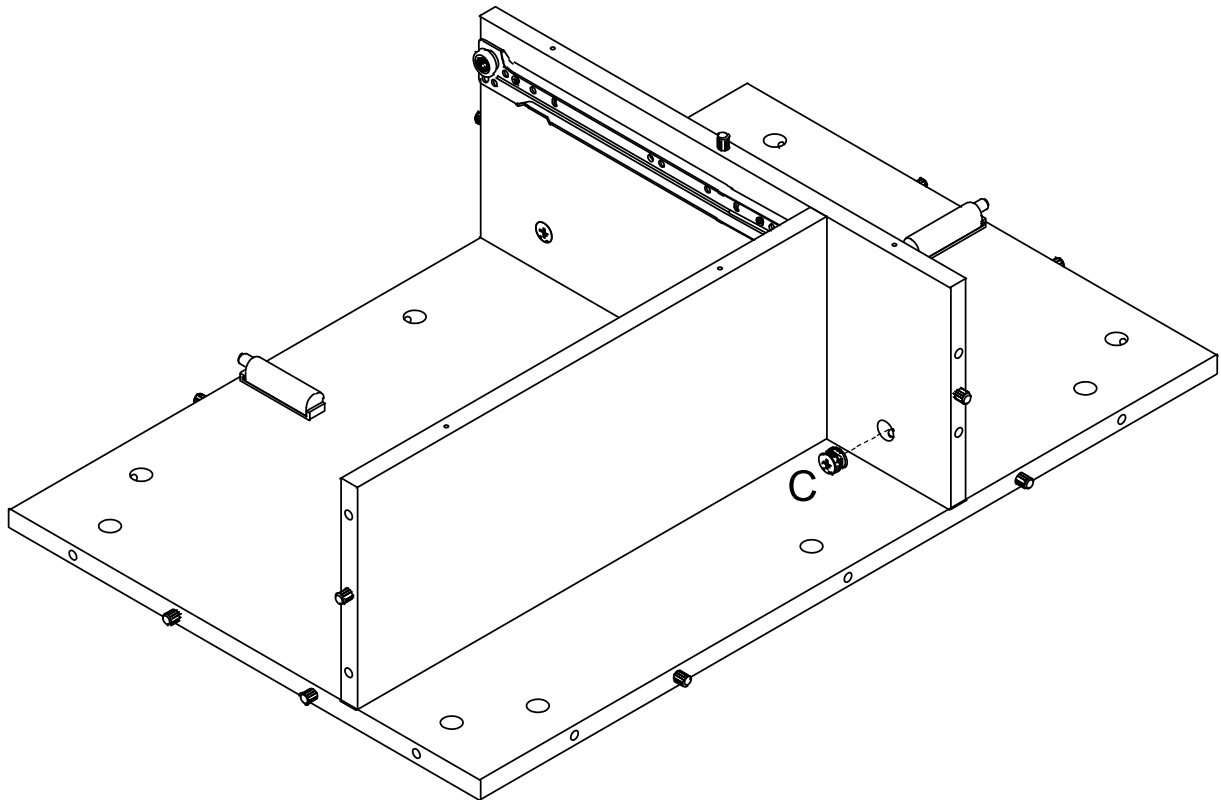
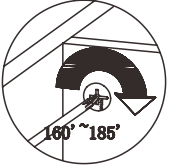
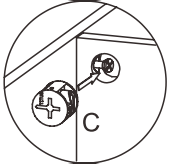
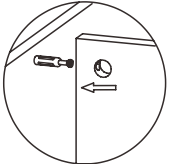
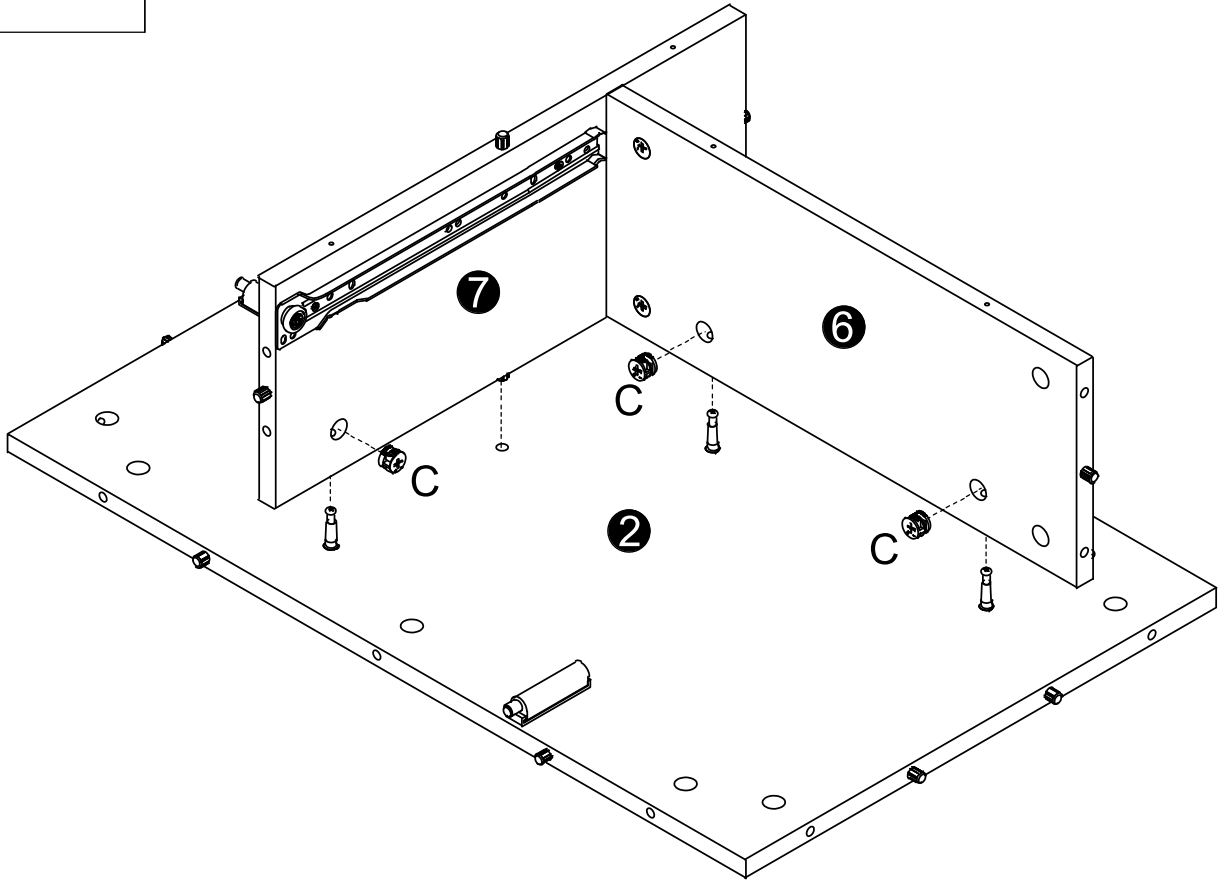

13

Cx6

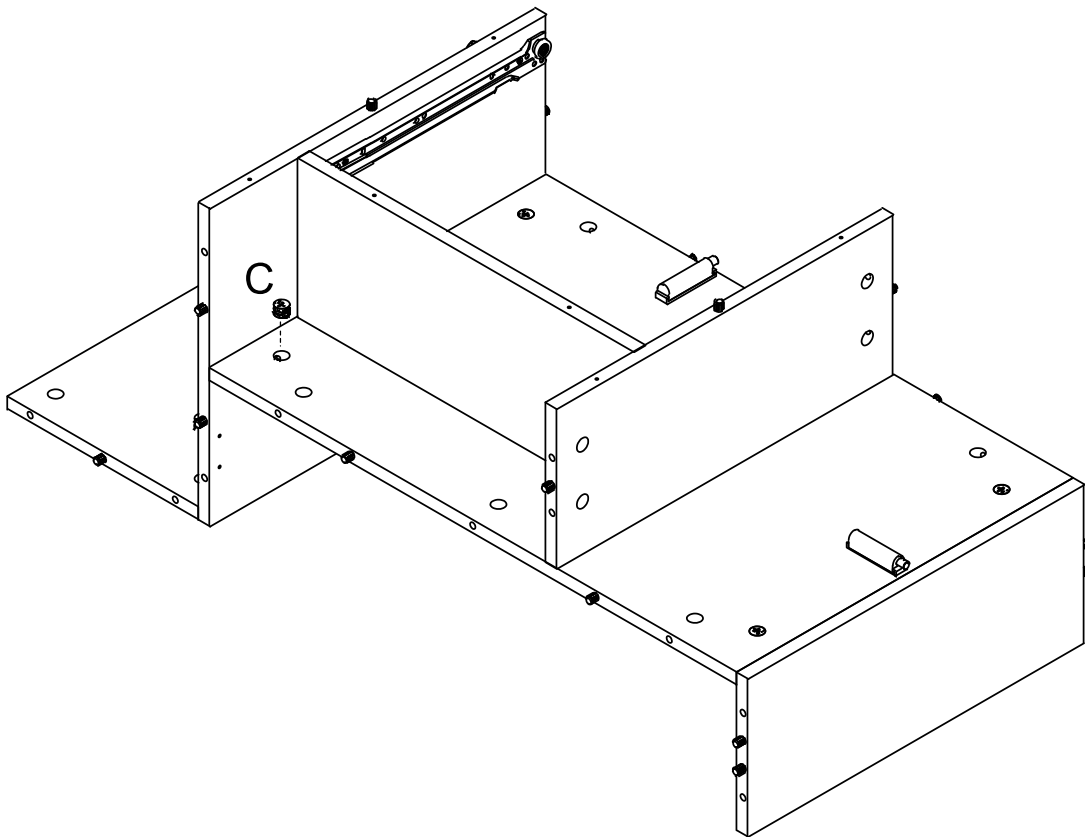
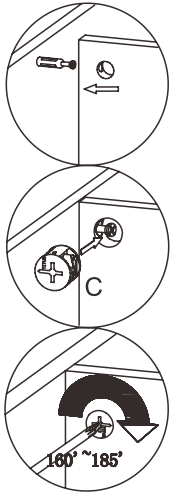
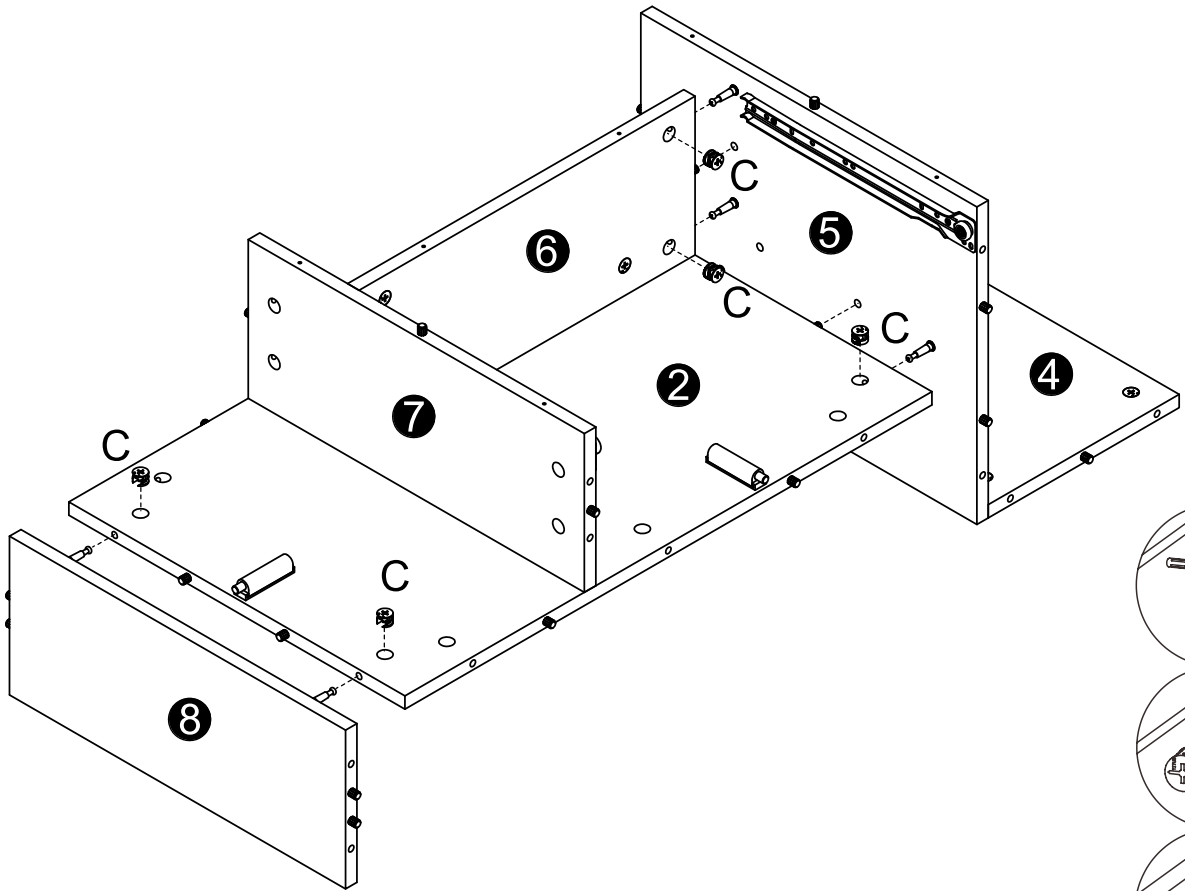

14

Cx22

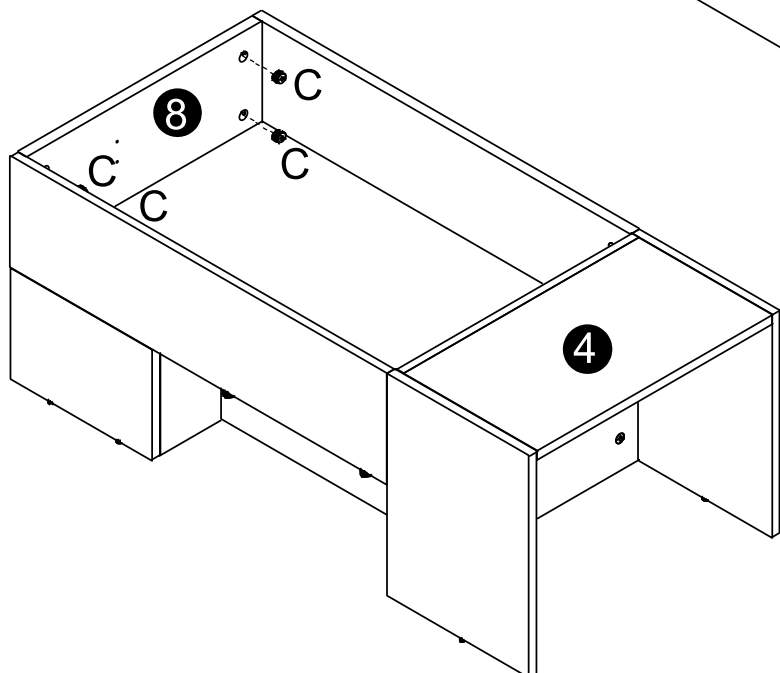
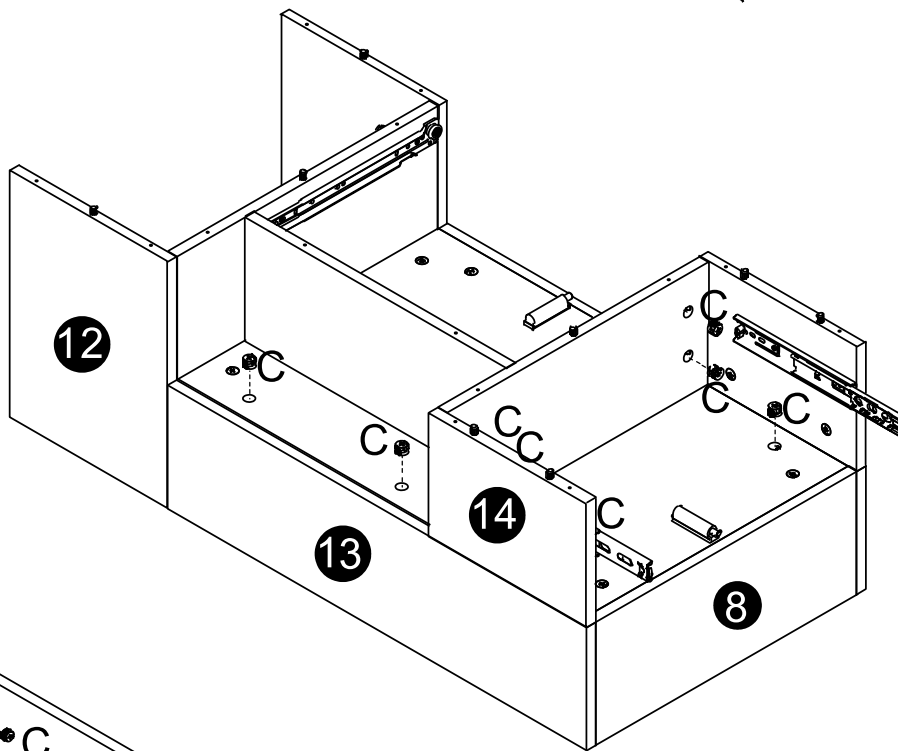
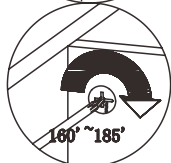
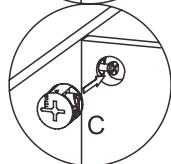
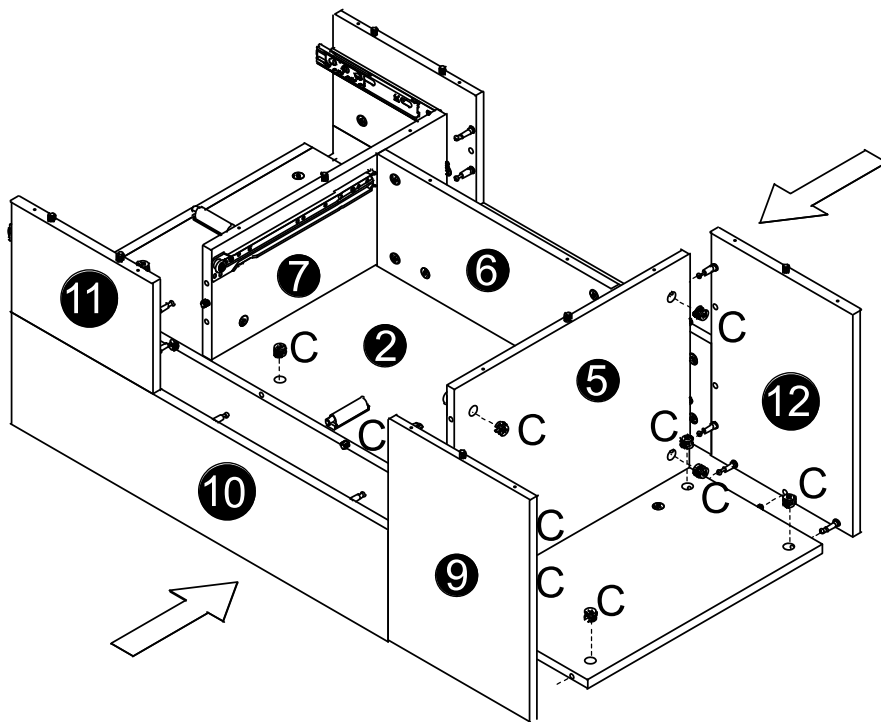

15

Ex14



φ3.5*35

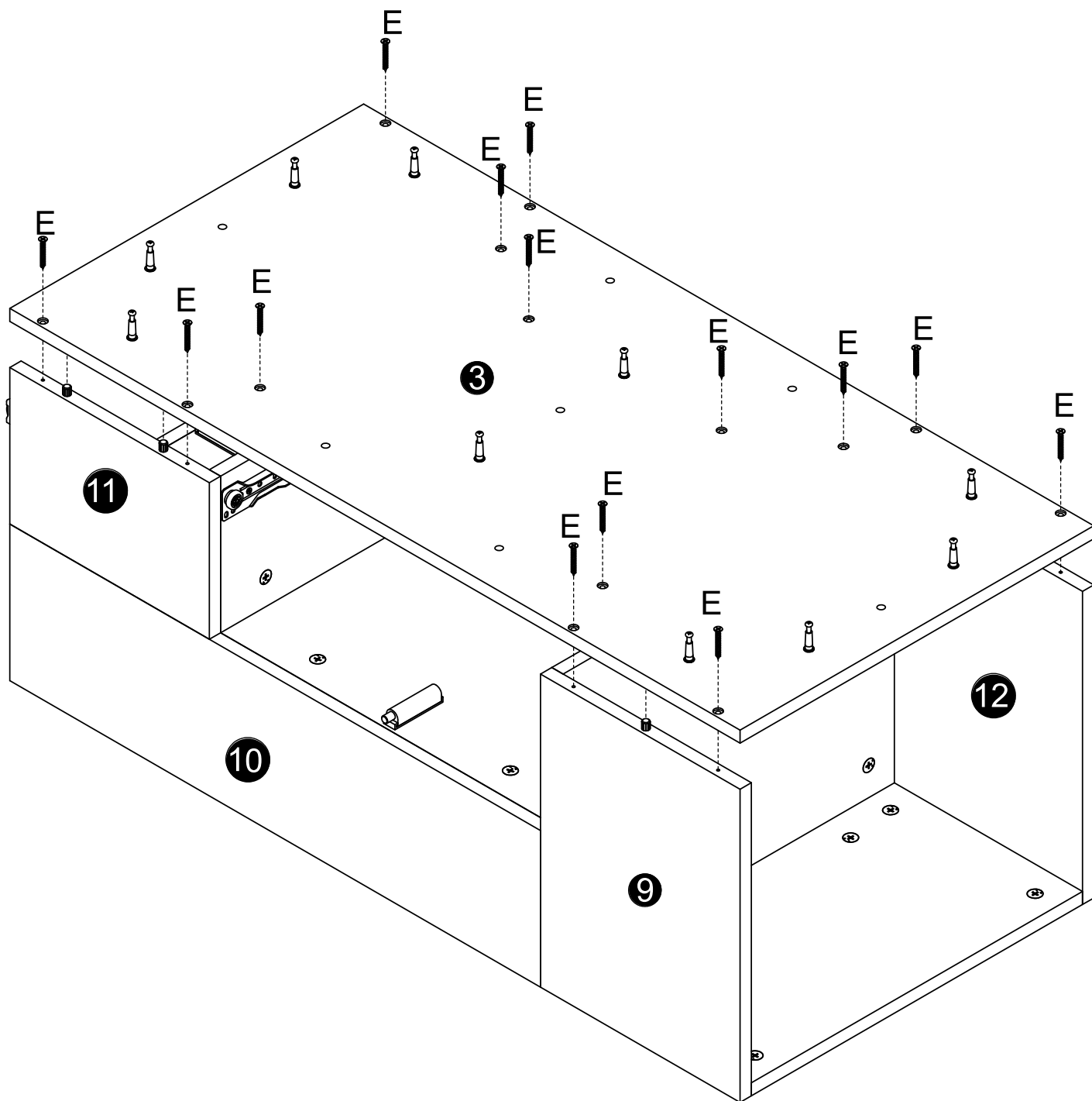

16

Cx6

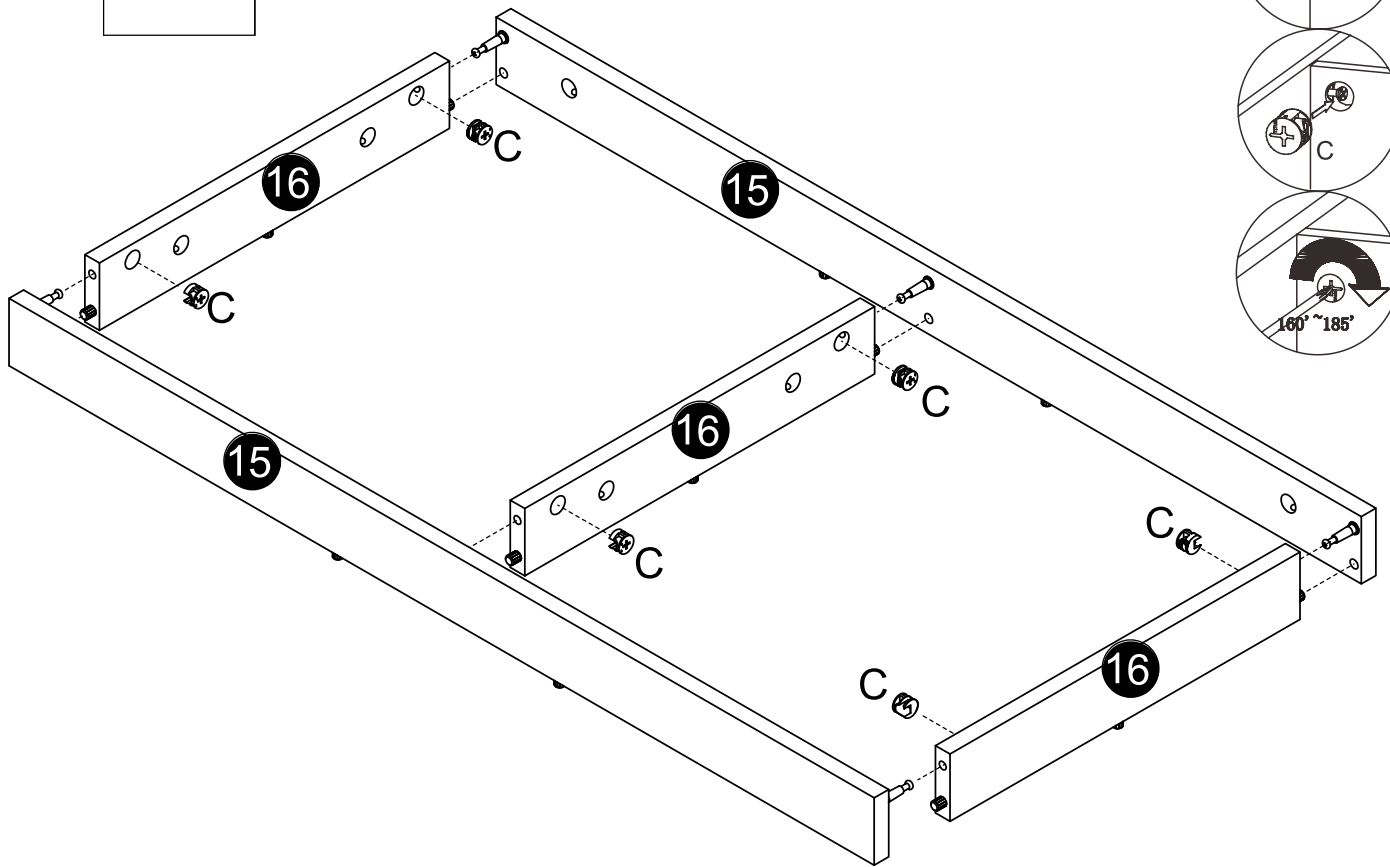
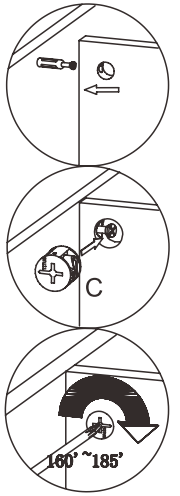

17

Fx8



φ3.5*14

I x1

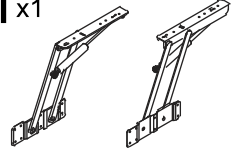

Left Side
Linke Seite
Côté Gauche
Lado Izquierdo
Lato Sinistro

Right Side
Rechte Seite
Côté Droit
Lado Derecho
Lato Destro

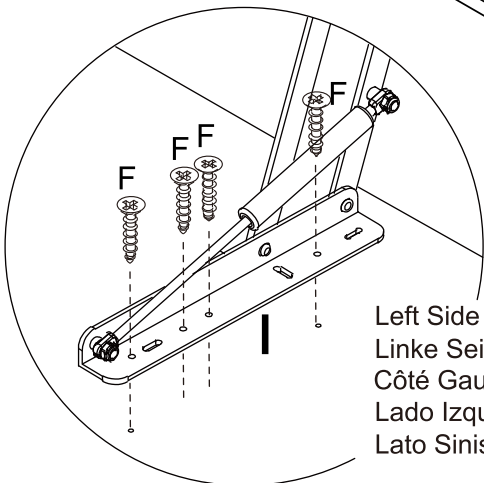
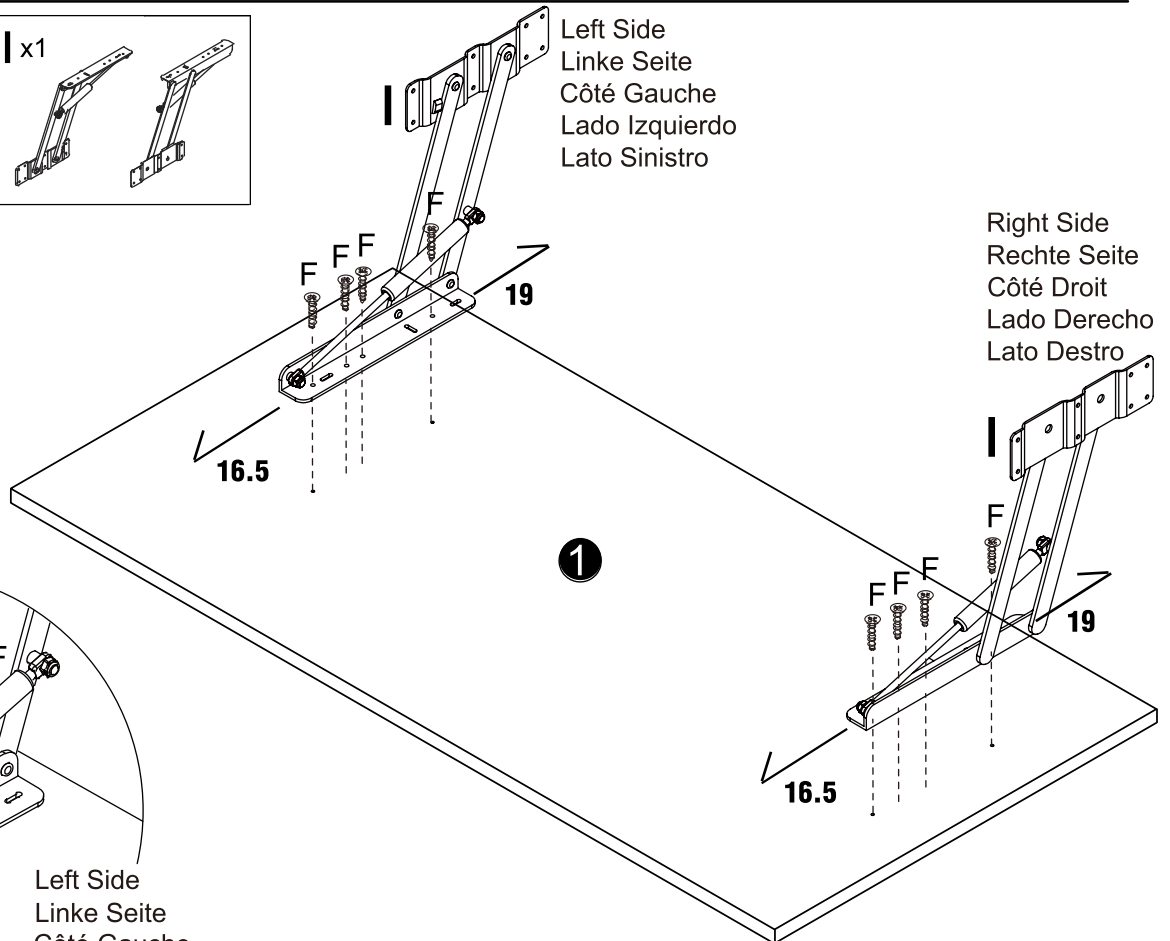

Left Side
Linke Seite
Côté Gauche
Lado Izquierdo
Lato Sinistro

18

Cx10

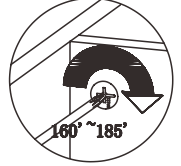
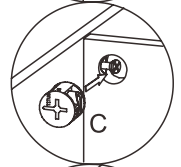
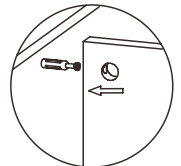
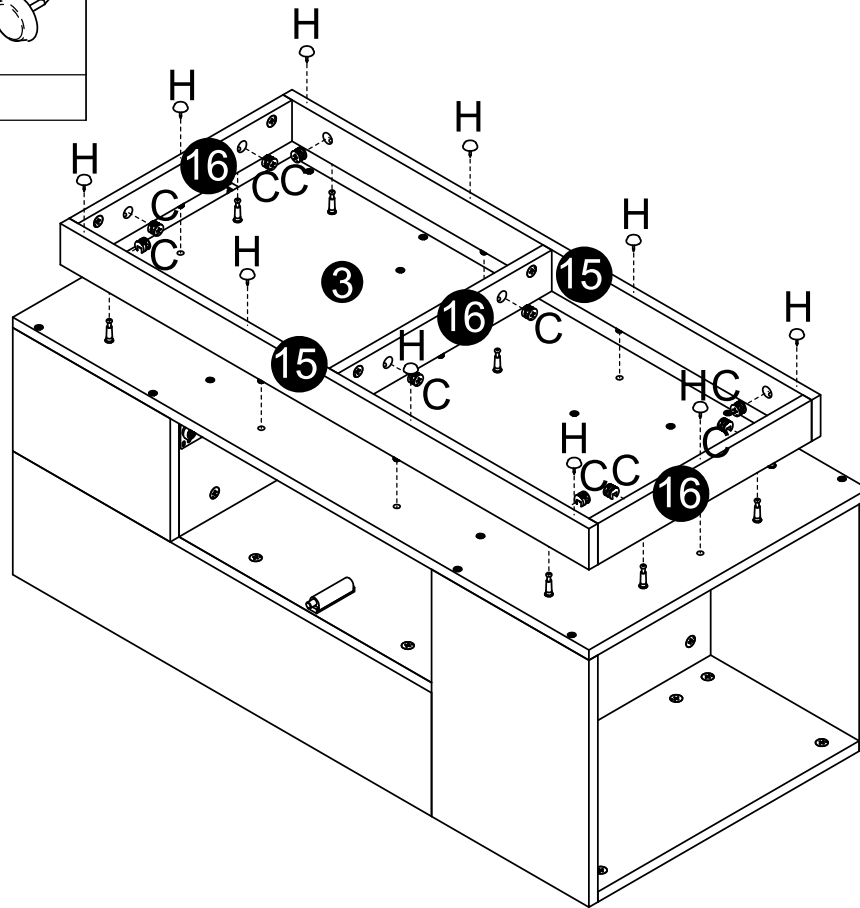

Hx10

**19**

Lx1



2800mm



DE:Scannen Sie den QR-Code, um die App zur Steuerung des LED-Lichts herunterzuladen.

EN:Scan the QR code to download the app to control the LED light.

IT:Scansiona il codice QR per scaricare l'app per controllare la luce LED.

FR:Scannez le code QR pour télécharger l'application afin de contrôler la lumière LED.

ES:Escanea el código QR para descargar la aplicación y controlar la luz LED.

EN:Tearoff the back tape
 FR:Déchirer le ruban adhésif arrière
 DE:Reiß das hintere Band ab
 IT:Rimuovere il nastro posteriore
 ES:Arranca la cinta trasera

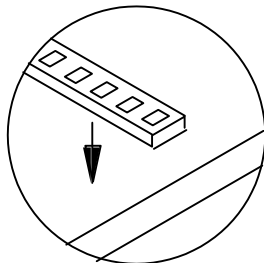
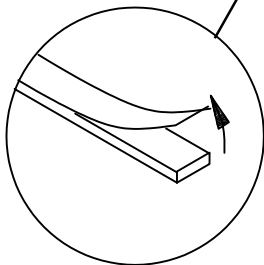
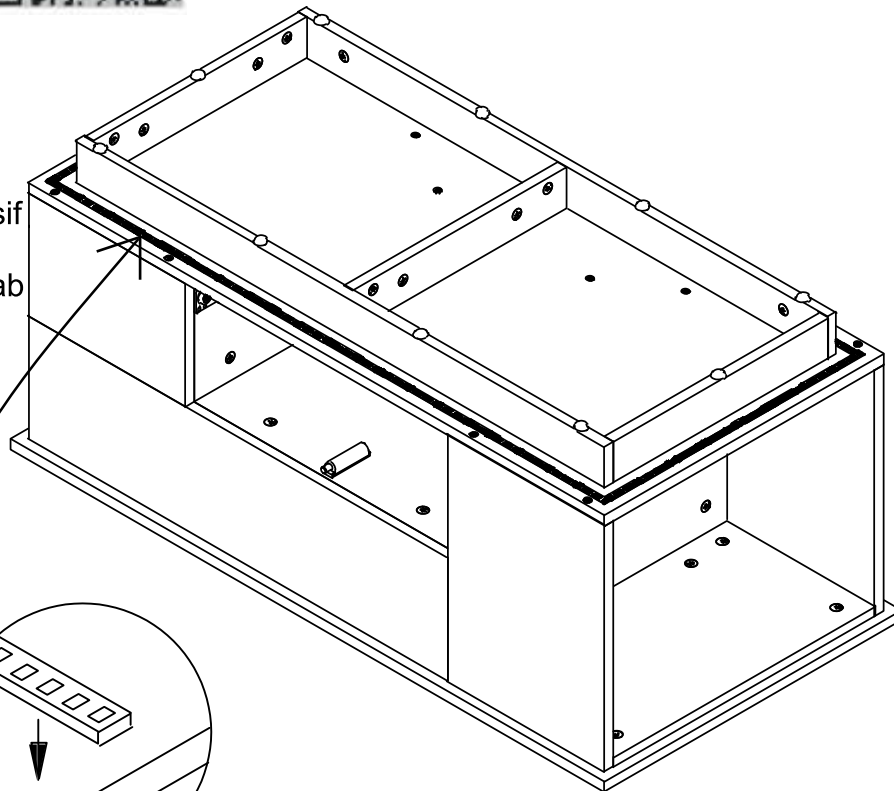

20

Fx16



φ3.5*14

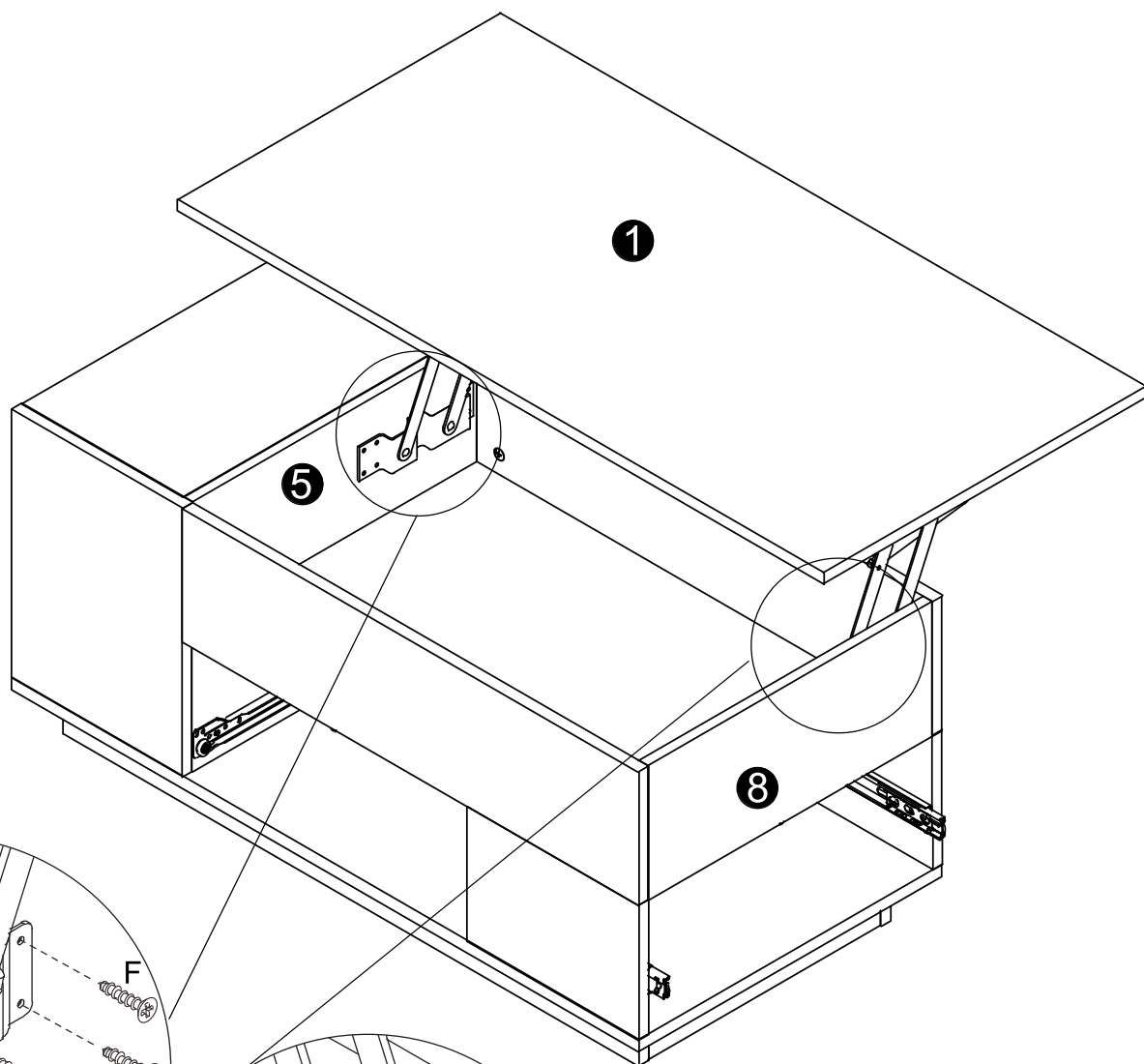



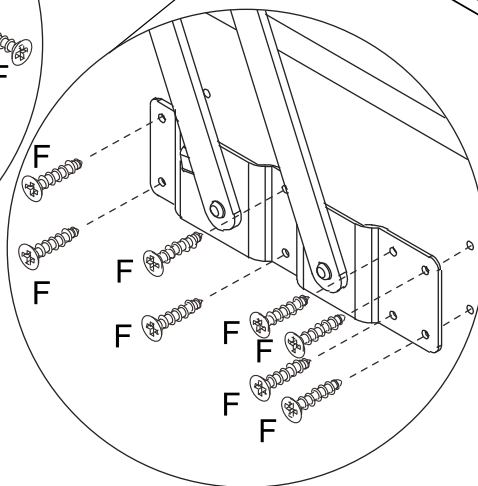
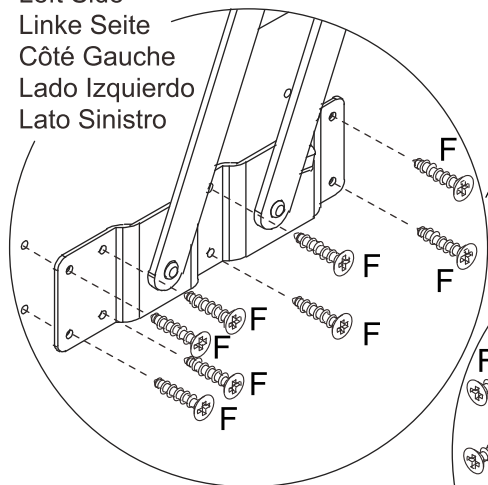

Left Side
Linke Seite
Côté Gauche
Lado Izquierdo
Lato Sinistro



Right Side
Rechte Seite
Côté Droit
Lado Derecho
Lato Destro

21

Ex4 	Cx4 	G3x1  DL	G4x1  DR	F x4 
$\phi 3.5 \times 35$				$\phi 3.5 \times 14$

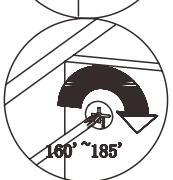
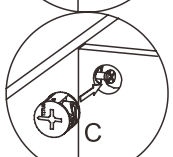
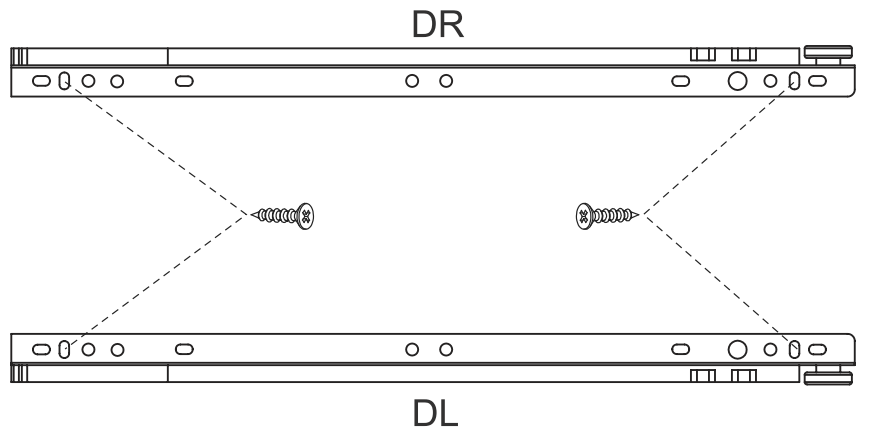
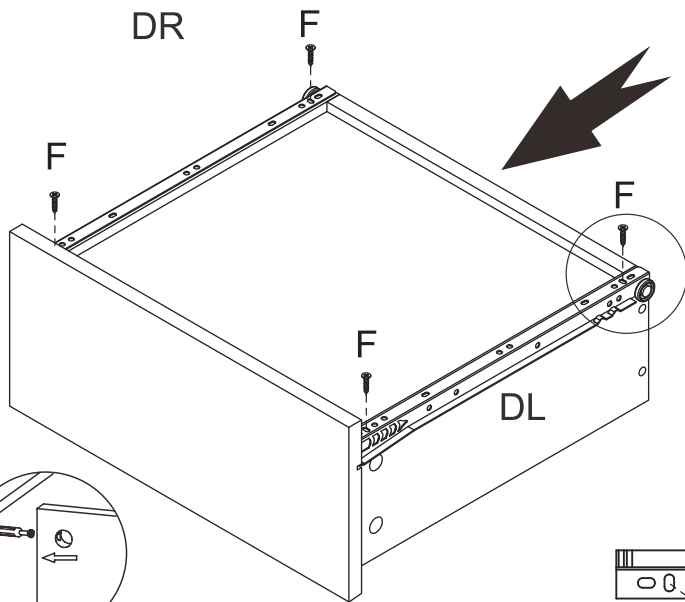
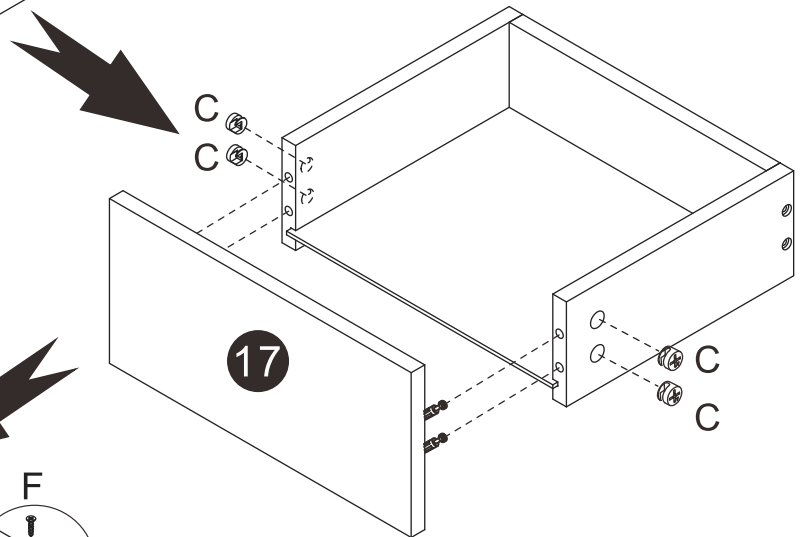
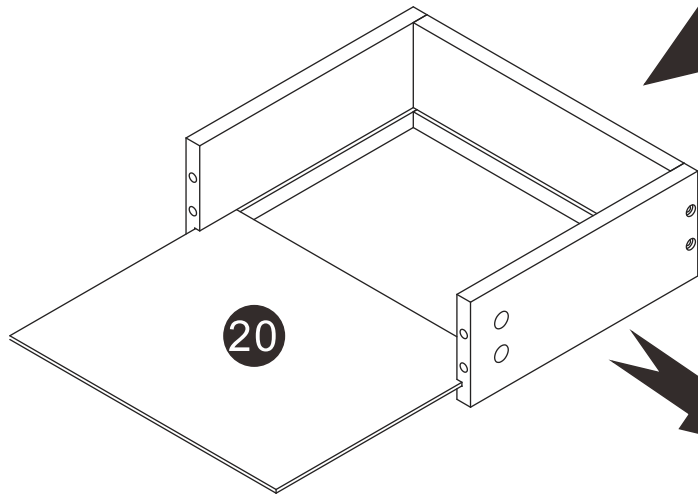
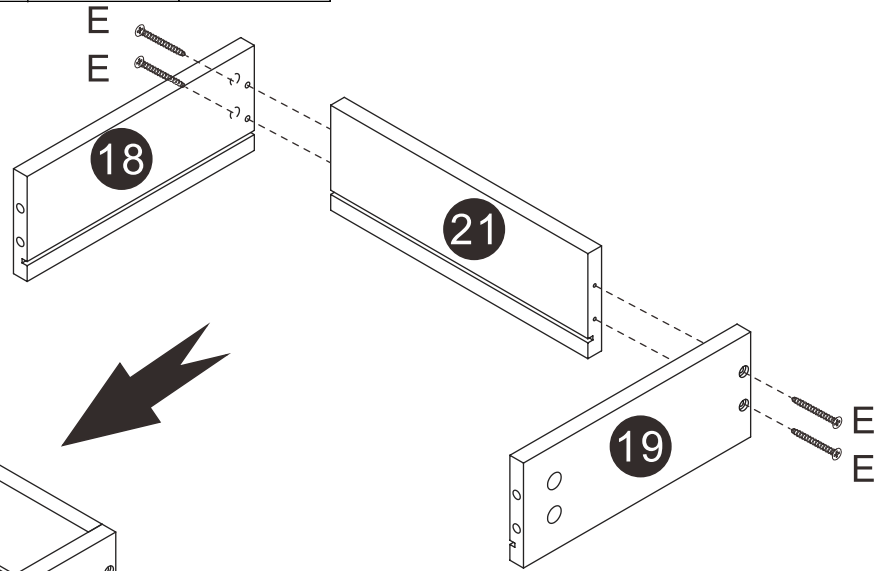

22

Ex4



φ3.5*35

Cx4

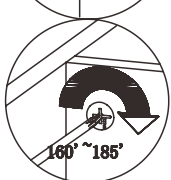
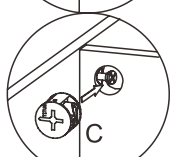
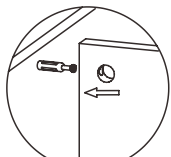
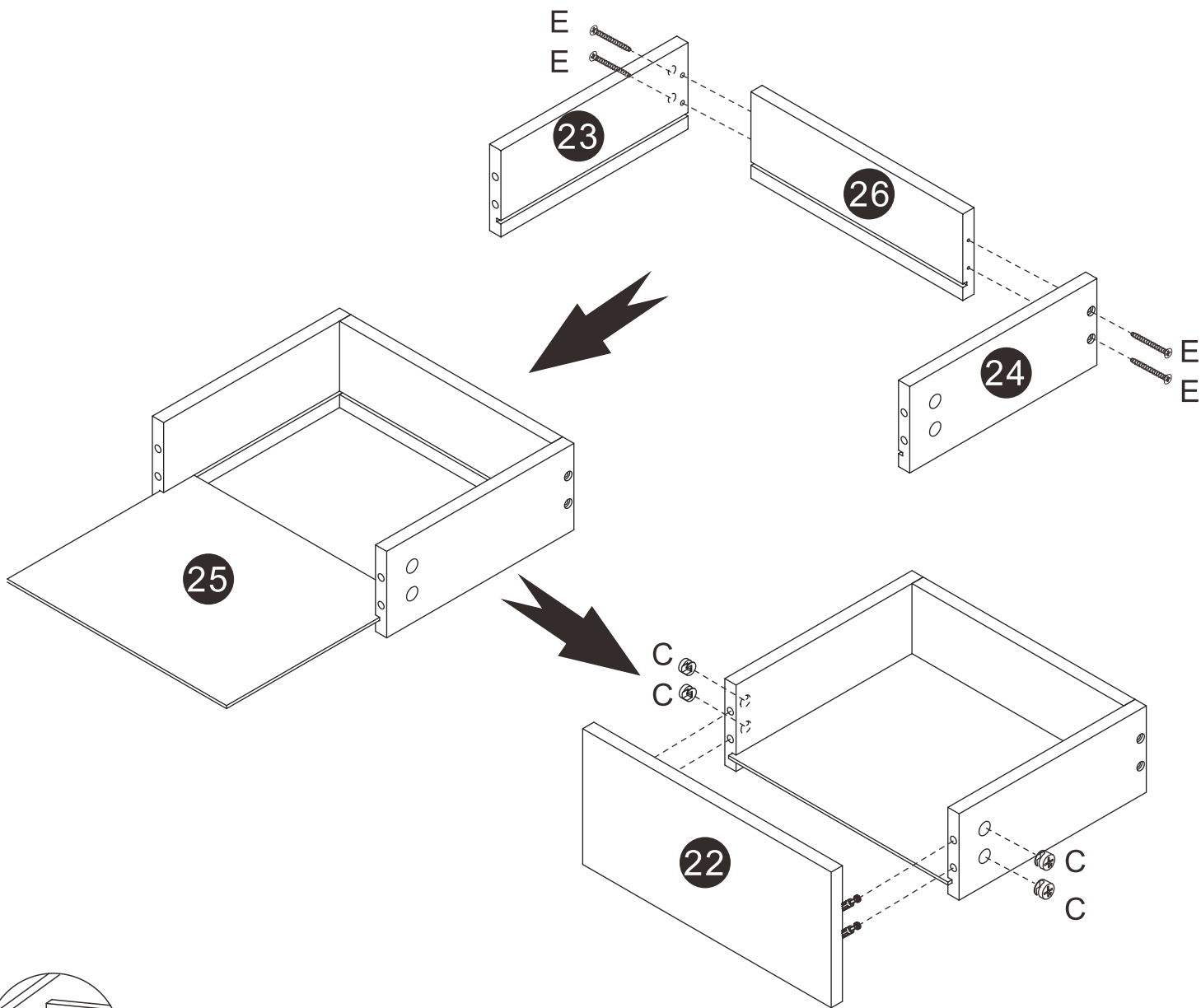

23

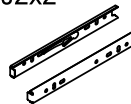
Fx4 	J2x2 
$\phi 3.5 \times 14$	

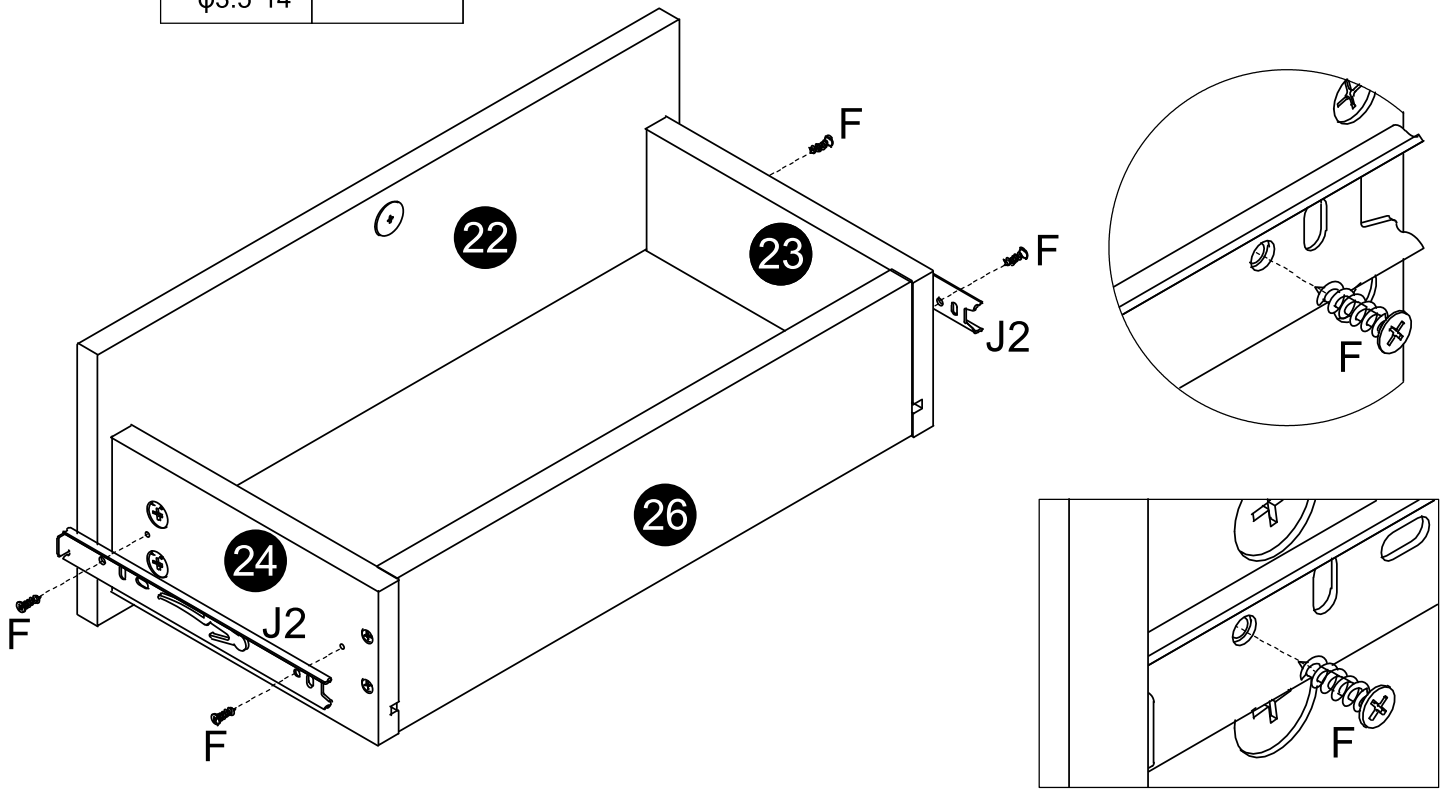

24

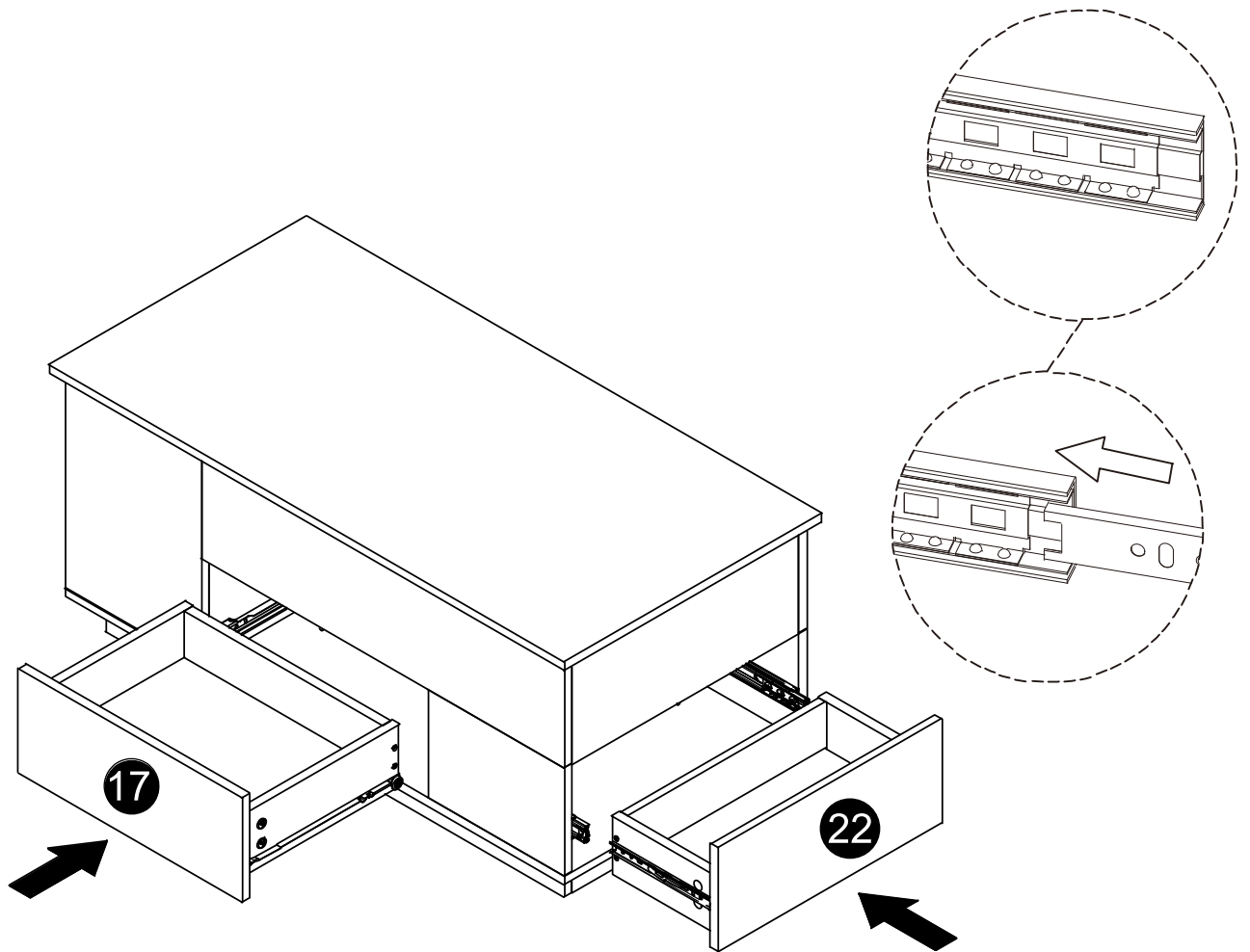

25

Ax24



Bx16



φ8*40

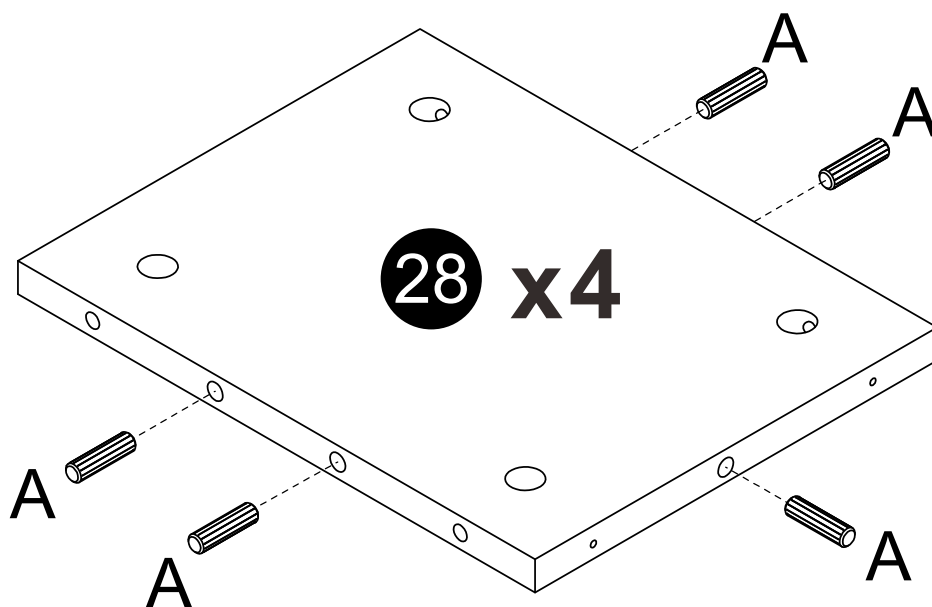
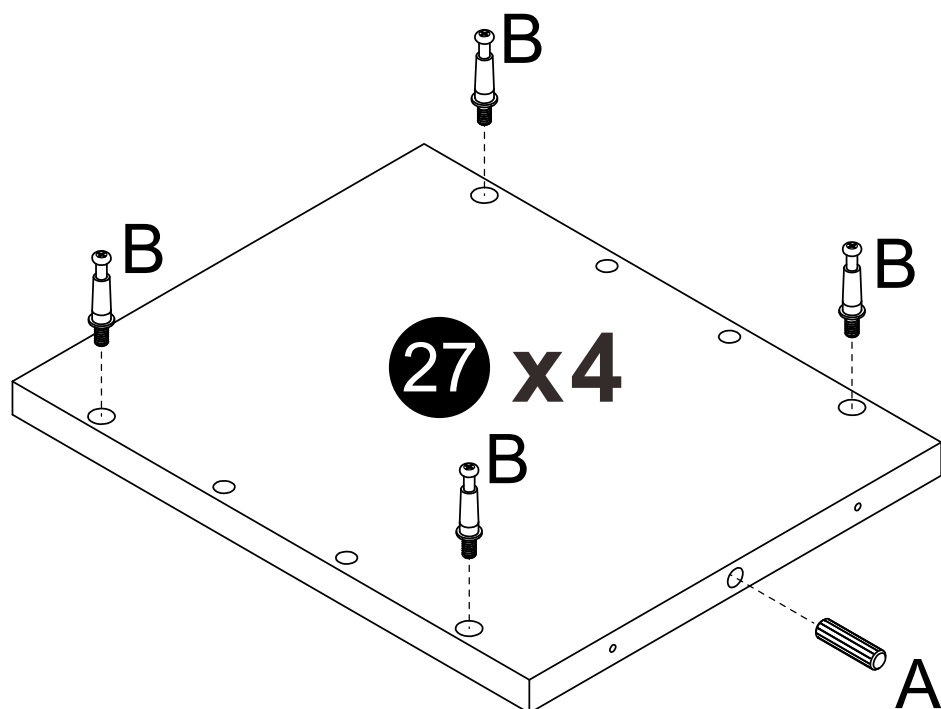

26

Cx16

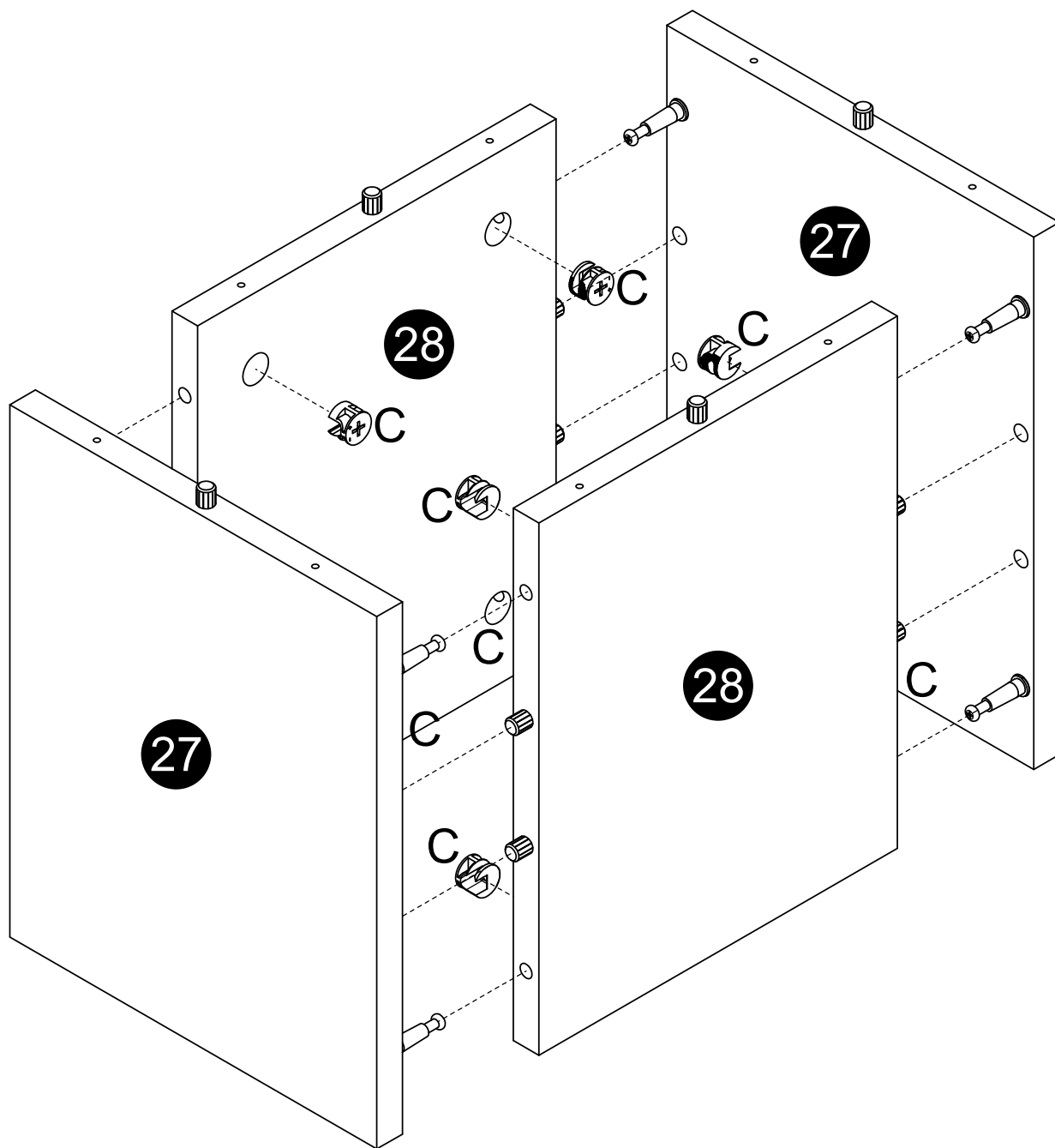

x2

27

Mx16



φ3.5*30

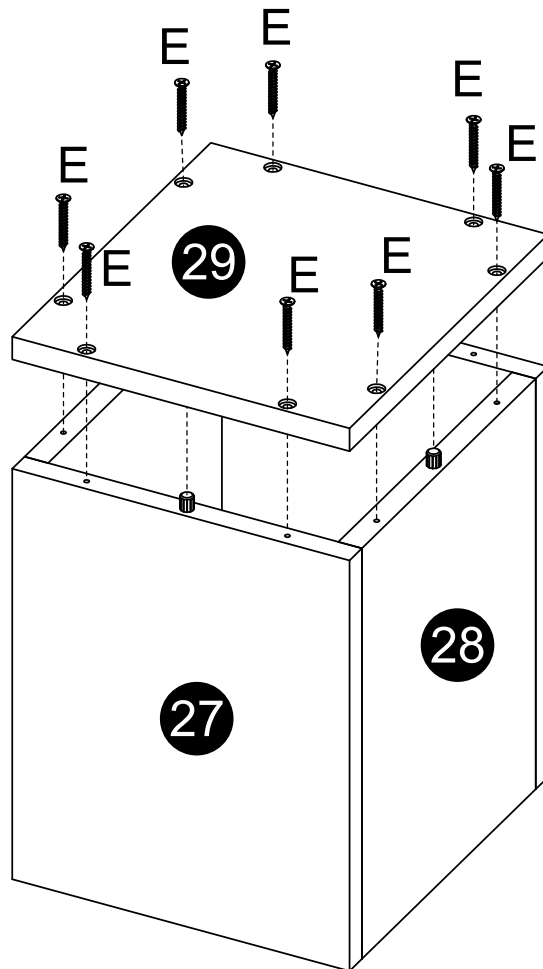

x2

28

Hx8

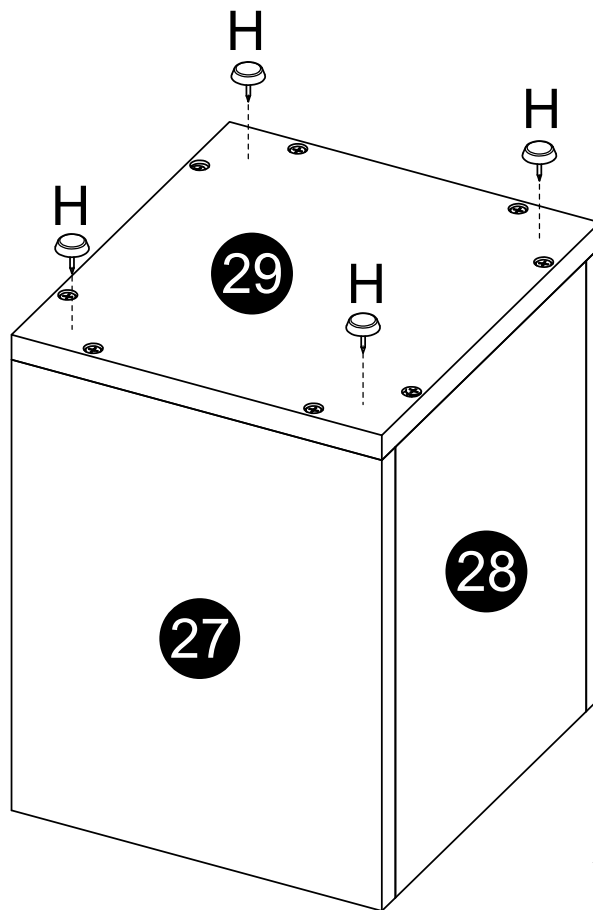

x2

29

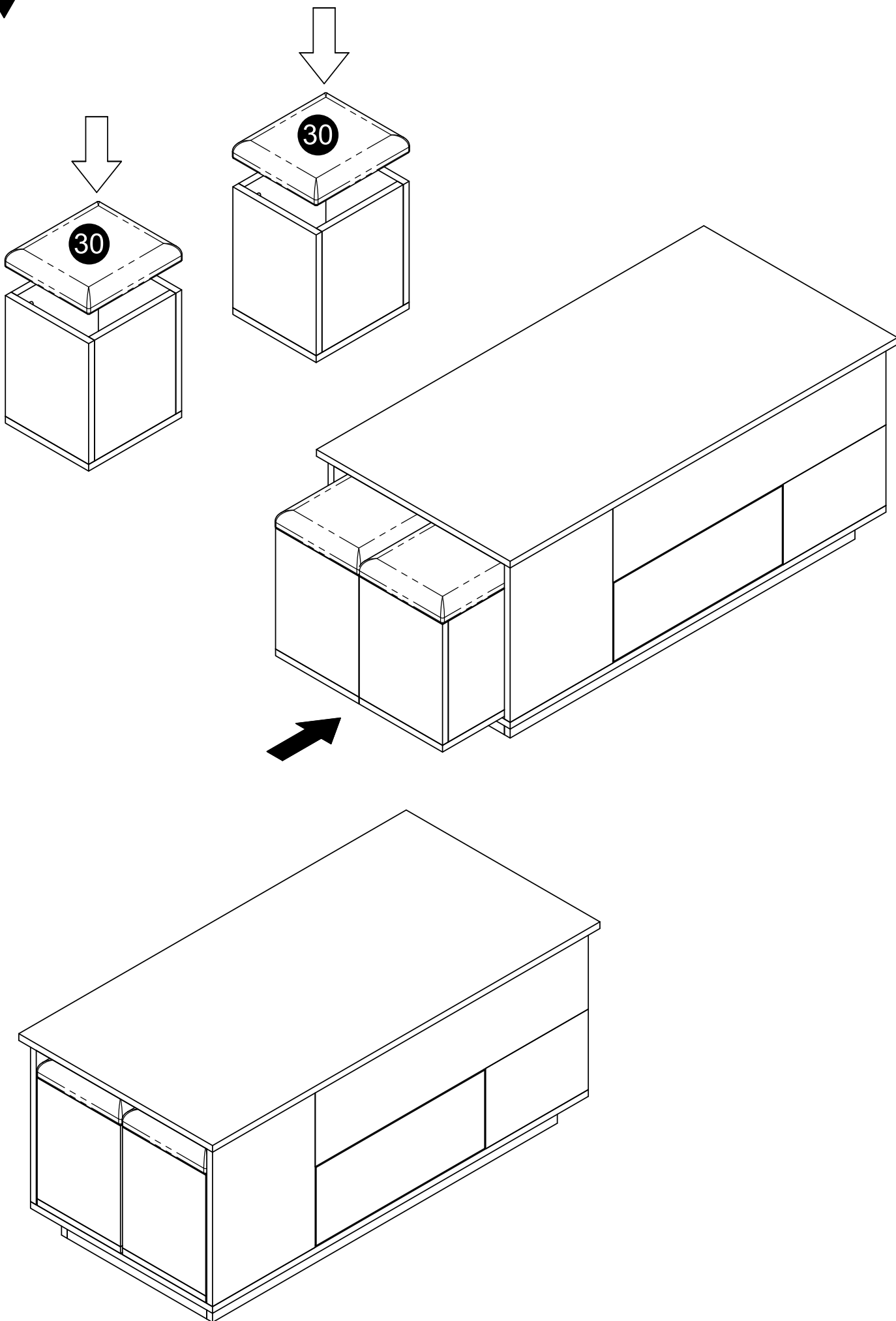

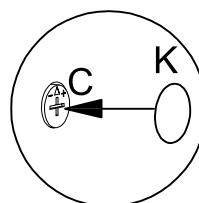
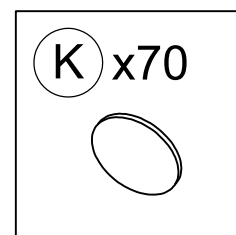
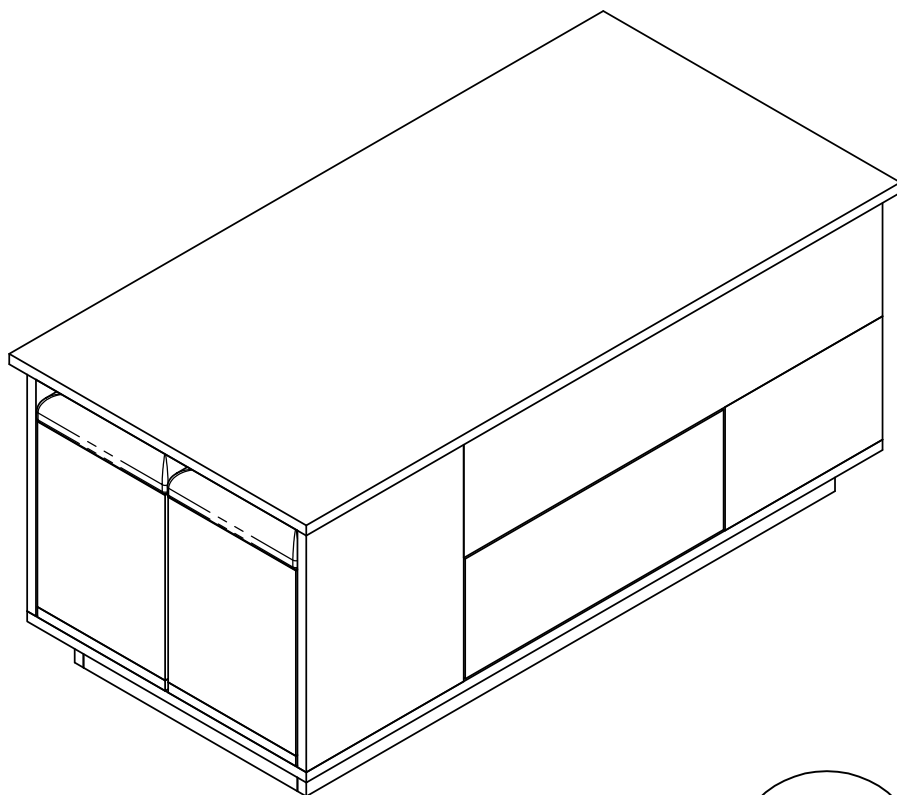

UK: After installing the product, stick the number K on the perforated position

FR: Une fois le produit installé, collez le numéro K à l'endroit où il y a des trous

DE: Nach der Installation des Produkts kleben Sie die Nummer K auf die perforierte Position

IT:Dopo l'installazione del prodotto, fissare il numero K sulla posizione perforata

ES:Después de instalar el producto, pegue el número K en la posición perforada

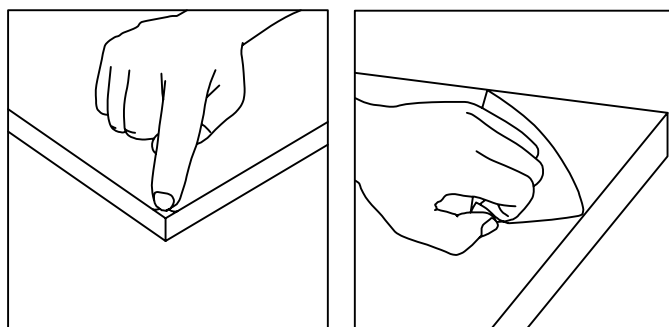

[DE]

BITTE BEACHTEN: Teilenummer 1.8.9.10.11.12 .13.14.17.2 2 ist mit einer dichten Kunststoffschutzfolie überzogen. Wenn das Produkt nach der Demontage Kratzer aufweist, machen Sie sich bitte keine Sorgen, es handelt sich nicht um einen Produktschaden. Bitte ziehen Sie die schützende Kunststoffolie langsam entlang der Kante von der Oberfläche ab. Nach dem Abziehen wird das Produkt glatt und sauber.

[EN]

PLEASE NOTE:Part number 1.8.9.10.11.12.13.14.17.22 are covered with a tight plastic protective film. If there are scratches on the product after disassembly, please don't worry, it's not product damage. Please slowly tear off the protective plastic film on the surface along the edge. After peeling off, the product becomes smooth and clean.

[FR]

REMARQUE : les pièces numéro 1.8.9.10.11.12.13.14.17.22 sont recouvertes d'un film protecteur en plastique étanche. Si le produit présente des rayures après le démontage, ne vous inquiétez pas, il ne s'agit pas d'un dommage au produit. Retirez lentement le film protecteur en plastique sur la surface le long du bord. Une fois décollé, le produit devient lisse et propre.

[IT]

NOTA BENE: il numero di parte 1.8.9.10.11.12.13.14.17.22 è coperto da una pellicola protettiva in plastica stretta. Se ci sono graffi sul prodotto dopo lo smontaggio, non preoccuparti, non è un danno al prodotto. Strappare lentamente la pellicola protettiva in plastica sulla superficie lungo il bordo. Dopo averla staccata, il prodotto diventa liscio e pulito.

[ES]

NOTA: La pieza número 1.8.9.10.11.12.13.14.17.22 está cubierta con una película protectora de plástico. Si hay rayones en el producto después de desmontarlo, no se preocupe, no se trata de daños en el producto. Retire lentamente la película protectora de plástico de la superficie a lo largo del borde. Después de despegarla, el producto quedará liso y limpio.

Certificate

Certificate Number: UNIA23010714EC-11



Product: LED low voltage light belt
Applicant: Shenzhen Light Belt Cloud Chain Lighting Co., Ltd
303 Xingfu Building, Tongfu Industrial Zone, Aiqun Road, Shangwu
Community, Shiyan Street, Bao'an District, Shenzhen
Manufacturer: Shenzhen Light Belt Cloud Chain Lighting Co., Ltd
303 Xingfu Building, Tongfu Industrial Zone, Aiqun Road, Shangwu
Community, Shiyan Street, Bao'an District, Shenzhen
Model No.: SMD 12V-2835-120, SMD 12V-2835-60, SMD 12V-2835-180,
SMD 12V-2835-240
Trade Mark: N/A
Test Methods: EN IEC 55015:2019+A11:2020 EN 61547:2009

The laboratory tested the product provided by the applicant according to the above test methods. According to the test results, the product conforms to EMC Directive (2014/30/EU) issued by the European Commission. It is possible to use CE marking to demonstrate the compliance with EMC Directive.

The certificate applies to the tested sample above mentioned only and shall not imply an assessment of the whole production. It is only valid in connection with the test report number: UNIA23010714ER-11.

Feb.09,2023

Issue Date

A handwritten signature in black ink, appearing to read 'Hoffer Lau'.

Hoffer Lau



Shenzhen United Testing Technology Co., Ltd.

Shenzhen:2/F.,Annex Building,Jiahuangyuan Tech Park, No.365, Baotian 1 st Road, Tiegang, Xixiang Street,

Bao'an District, Shenzhen, Guangdong, China/518050

Guangzhou:No.47-3, Industrial Road, Zhushan, Dalong Street, Panyu District, Guangzhou, Guangdong,

China/511450

Tel:+86-755-86180996/+86-020-39277769 Fax:+86- 0755-86180156

Web.Site:www.uni-lab.hk/ E-mail:hofferlau@uni-lab.hk



Certificate of Compliance