

DE:Installationsanleitung  
 UK:Installation Instruction  
 FR:Instruction d'installation  
 IT:Istruzioni di installazione  
 ES: Instrucciones de instalación  
 NL: Installatie-instructies  
 SE: Installationsanvisningar  
 PL:Instrukcje instalacji  
**N620P347797/N620P347798/N620P347799**

DE:Unser Produkt wird Ihnen in 3 Paketen geliefert. Die Lieferzeiten dieser 3 Pakete können abweichen, bitte haben Sie etwas Geduld und vielen Dank für Ihr Verständnis.

UK:Our product will be delivered to you in 3 packages. The delivery times of these 3 packages may differ, please be patient and thank you for your understanding.

FR:Notre produit vous sera livré en 3 colis. Les délais de livraison de ces 3 colis peuvent différer, soyez patient et merci pour votre compréhension.

IT: Il nostro prodotto verrà consegnato in 3 pacchi. I tempi di consegna di questi 3 pacchi possono variare; vi preghiamo di avere un po' di pazienza e vi ringraziamo per la vostra comprensione.

ES: Nuestro producto se entregará en 3 paquetes. Los tiempos de entrega de estos 3 paquetes pueden variar; por favor, tenga un poco de paciencia y gracias por su comprensión.

NL: Ons product wordt in 3 pakketten bij u geleverd. De levertijden van deze 3 pakketten kunnen verschillen, we vragen om uw geduld en bedanken u voor uw begrip.

SE: Vår produkt kommer att levereras till dig i 3 paket. Leveranstiderna för dessa 3 paket kan variera, vi ber om ditt tålamod och tackar för din förståelse.

PL: Nasz produkt zostanie dostarczony w 3 paczkach. Czas dostawy tych 3 paczek może się różnić, prosimy o cierpliwość i dziękujemy za zrozumienie.

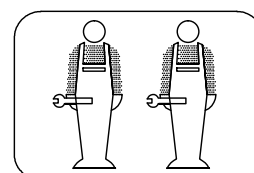
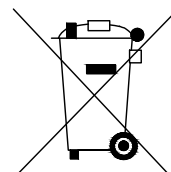
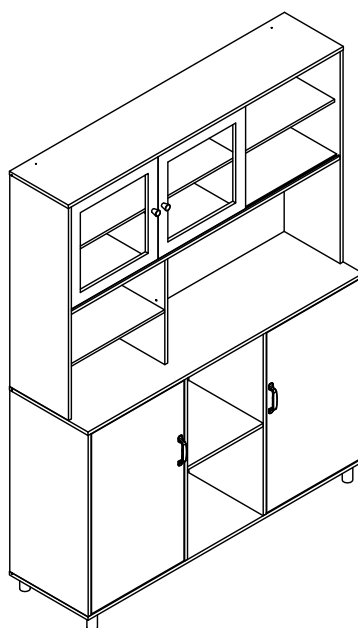

Importeur	Decobus Handel GmbH
Adresse	Innungsstraße 9,21244 Buchholz, Deutschland
Email/URL	<a href="https://www.decobusgroup.de">https://www.decobusgroup.de</a>
Hersteller	ZHANGZHOU SHUJIAN FURNITURE CO.,LTD
Adresse	ROOM 101,BUILDING 21,NO.60 BAOXING ROAD, XIANGCHENG DISTRICT,ZHANGZHOU,FUJIAN,CHINA
Email/URL	Freja_zsj@163.com
Partienummer	N620P347797/N620P347798/N620P347799
Hergestellt in	CHINA
EC REP	Decobus Handel GmbH Innungsstraße 9,21244 Buchholz, Deutschland <a href="https://www.decobusgroup.de">https://www.decobusgroup.de</a>

	
M3.5x14mm	M3.5x14mm
Ⓜx72pcs	Ⓜx2pcs

DE: Bitte beachten Sie, dass die Formen der Schrauben E und H ähnlich sind. Bitte installieren Sie entsprechend der Anleitung und unterscheiden Sie sie!

UK: Please note that the shapes of screws E and H are similar. Please install according to the instructions and distinguish them!

FR: Notez que les vis E et H ont des formes similaires. Veuillez les installer en suivant les instructions pour les séparer!

IT: Si prega di notare che le forme delle viti E e H sono simili. Si prega di installarle seguendo le istruzioni e di distinguerle!

ES: Por favor, tenga en cuenta que las formas de los tornillos E y H son similares. Por favor, instálelos de acuerdo con las instrucciones y distíngalos.

NL: Let op, de vormen van schroeven E en H zijn vergelijkbaar. Installeer volgens de instructies en maak onderscheid tussen ze!

SE: Observera att formerna på skruvarna och E och H är lika. Installera enligt anvisningarna och särskilj dem!

PL: Zauważ, że kształty śrub E i H i są podobne. Zainstaluj zgodnie z instrukcjami i rozróżnij je!

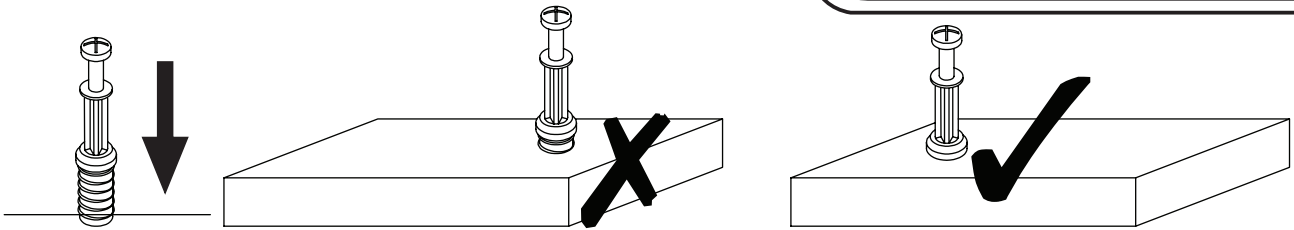

**EN\_QUICKFIT:** Tighten quickfit until shoulder is flush with panel. Do not overtighten or undertighten.

**FR\_RACCORD RAPIDE:** Faites serrer le raccord rapide jusqu'à ce que l'épaulement soit parfaitement encastré dans le panneau. Il ne faut ni trop serrer ni insuffisamment serrer.

**ES\_QUICKFIT:** Apriete quickfit hasta que el hombro se descargue con el panel. NO lo sobreapriete ni lo apriete poco.

**DE\_QUICKFIT:** Ziehen Sie den Quickfit fest, bis die Schulter mit der Platte bündig ist. Bitte nicht zu fest oder zu schwach anziehen.

**IT\_MONTAGGIO RAPIDO:** Stringere il montaggio rapido fino a quando la spalla è a filo con il pannello, non stringere troppo o troppo poco.

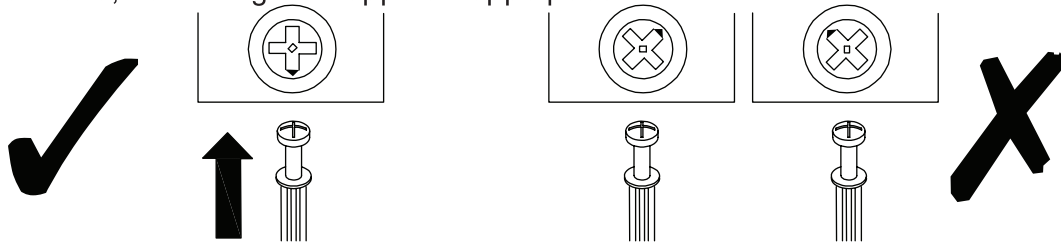

**EN\_CAM LOCK:** When fitting cam lock, ensure starting position is correct before you insert connecting quickfit.

**FR\_SERRURE BATTEUSE:** Avant d'insérer la serrure batteuse, veillez à la bonne orientation avant d'insérer le raccord rapide.

**ES\_CIERRE DE LA CÁMARA:** Cuando instale el cierre de la cámara, asegúrese de que la posición de inicio es correcta antes de que inserte el quickfit conector.

**DE\_CAM-LOCK:** Achten Sie bei der Montage des Cam-Locks auf die richtige Ausgangsposition, bevor Sie den Quickfit einsetzen.

**IT\_BLOCCAGGIO A CAMMA:** Quando si monta il bloccaggio a camma, assicurarsi che la posizione iniziale sia corretta prima di inserire il montaggio rapido di collegamento.

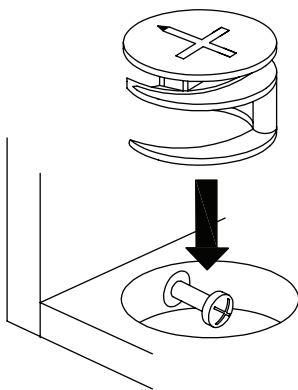

**EN\_Quickfit head** should be in the centre of the cam lock when the two panels are joined.

Cam lock should be inserted before quickfit.

**FR\_**Lorsque les deux panneaux sont assemblés, la tête du raccord rapide doit reposer au centre de la serrure batteuse. Il faut insérer la serrure batteuse avant le raccord rapide.

**ES\_**El cabezal del quickfit debe estar en el centro del cierre de la cámara cuando se unan los dos paneles.

Se debe insertar el cierre de la cámara antes que el quickfit.

**DE\_**Der Quickfit-Kopf sollte sich in der Mitte des Cam-Locks befinden, wenn die beiden Platten zusammengefügt sind. Der Cam-Lock sollte vor dem Quickfit eingesetzt werden.

**IT\_**La testa del montaggio rapido deve trovarsi al centro del bloccaggio a camma quando i due pannelli sono uniti.

Il Bloccaggio a Camma deve essere inserito prima del montaggio rapido.

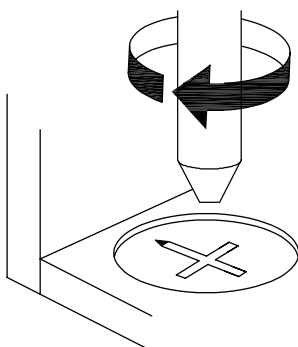

**EN\_**Turn cam lock clockwise to tighten.

**FR\_**Faites tourner la serrure batteuse dans le sens des aiguilles d'une montre pour la resserrer.

**ES\_**Gire el cierre de la cámara en sentido horario para apretarlo.

**DE\_**Drehen Sie den Cam-Lock im Uhrzeigersinn, um ihn festzuziehen.

**IT\_**Ruotare il bloccaggio a camma in senso orario per stringere.

DE:Vor dem Einbau die Schrauben in die Löcher stecken und festziehen, aber nicht bis 100%, 70% bis 80% anziehen reicht aus. Schließlich, nachdem alle Schrauben installiert sind, ziehen Sie alle Schrauben auf 100%.Wenn Sie auf diese Probleme stoßen, wie z. B. Fehlausrichtung der Löcher oder Unfähigkeit, bestimmte Teile zu installieren, überprüfen Sie bitte, ob die Schrauben korrekt verwendet werden und passen Sie die Dichtigkeit der Schrauben an.

UK:Before installation, insert the screws into the holes and tighten them, but do not tighten them to 100%, 70% to 80% is sufficient. Finally, after all screws are installed, tighten all screws to 100%.If you encounter these issues, such as if the holes cannot be aligned or some parts cannot be installed, please check if the screws are used correctly and adjust the tightness of the screws.

FR:Insérer la vis dans le trou avant la fin de l'assemblage, serrer la vis, mais ne pas serrer à 100%, 70% ~ 80% est correct. Enfin, une fois que toutes les vis sont bien serrées, toutes les vis sont serrées à 100%.Si vous rencontrez ces problèmes, par exemple si les trous ne sont pas alignés ou si certaines pièces ne peuvent pas être montées, vérifiez que les vis sont utilisées correctement et Ajustez leur serrage.

IT:Prima dell'installazione, inserire le viti nei fori e stringerle, ma non al 100%, è sufficiente stringerle al 70% - 80%. Infine, dopo aver installato tutte le viti, stringere tutte le viti al 100%. Se riscontri problemi come disallineamenti dei fori o difficoltà nell'installare alcuni componenti, verifica che le viti siano utilizzate correttamente e regola la tensione delle viti.

ES:Antes de la instalación, coloque los tornillos en los agujeros y apriéte los, pero no al 100%; apretar al 70% - 80% es suficiente. Finalmente, después de haber instalado todos los tornillos, apriete todos los tornillos al 100%. Si se encuentra con problemas como desalineación de los agujeros o dificultad para instalar ciertas piezas, verifique que los tornillos se estén utilizando correctamente y ajuste la tensión de los tornillos.

NL:Voordat u begint met de installatie, plaatst u de schroeven in de gaten en draait u ze aan, maar draai ze niet volledig aan; 70% tot 80% is voldoende. Draai uiteindelijk, nadat alle schroeven zijn geplaatst, alle schroeven volledig aan. Als u problemen ondervindt, zoals niet uitgelijnde gaten of onderdelen die niet kunnen worden geïnstalleerd, controleer dan of de schroeven correct zijn gebruikt en pas de spanning van de schroeven aan.

SE:Innan installation, sätt i skruvarna i hålen och dra åt dem, men dra inte åt dem helt; 70% till 80% är tillräckligt. Slutligen, när alla skruvar är installerade, dra åt alla skruvar helt. Om du stöter på problem, som att hålen inte kan justeras eller vissa delar inte kan installeras, kontrollera om skruvarna används korrekt och justera skruvarnas åtdragning.

PL:Przed instalacją wstaw śruby w otwory i dokręć je, ale nie dokręcaj ich na 100%; 70% do 80% wystarczy. Na koniec, po zainstalowaniu wszystkich śrub, dokręć wszystkie śruby do 100%. Jeśli napotkasz problemy, takie jak niedopasowane otwory lub części, które nie mogą być zainstalowane, sprawdź, czy śruby są używane prawidłowo i dostosuj ich dokręcenie.

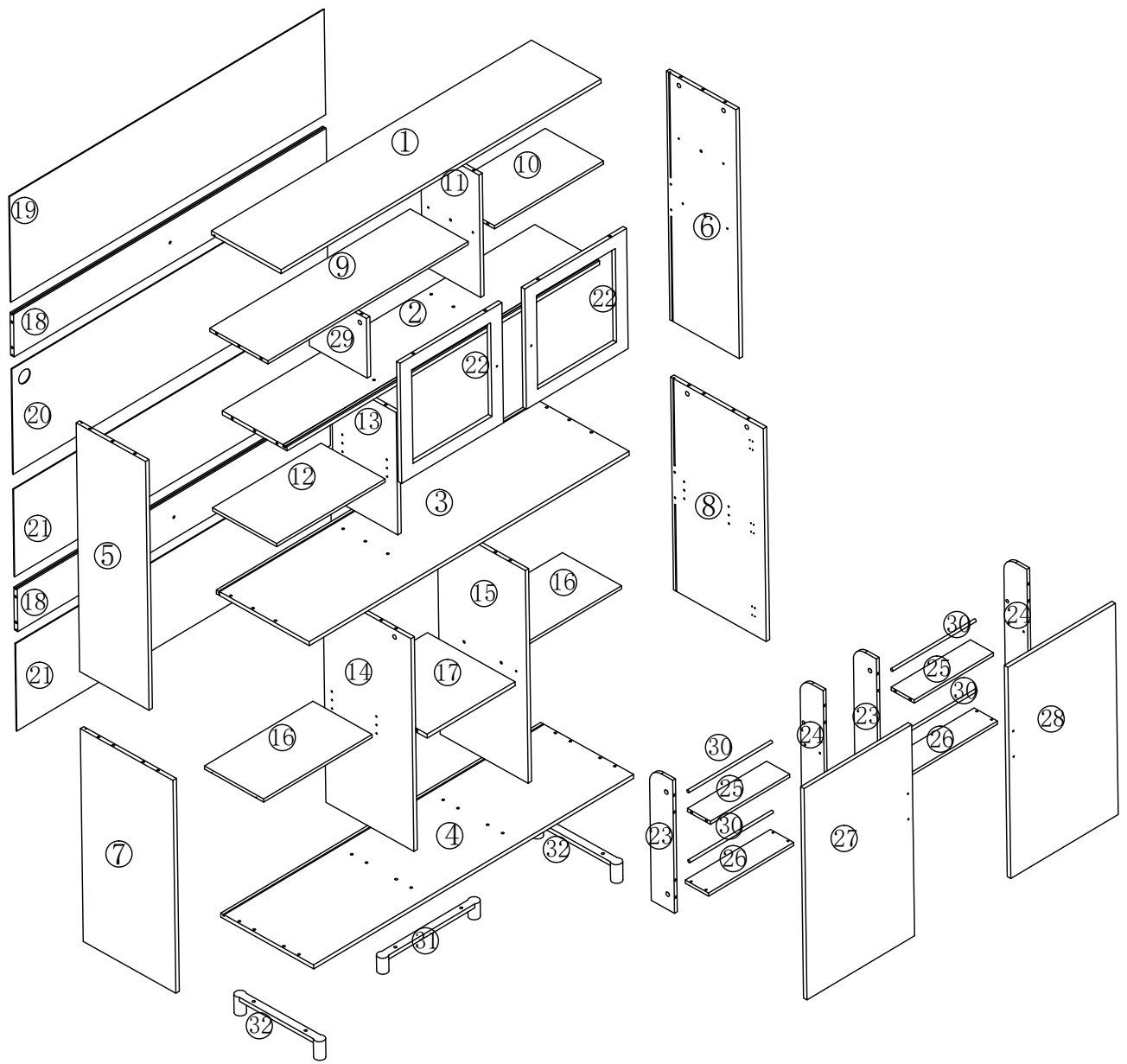

### N620P347797

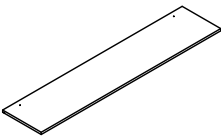
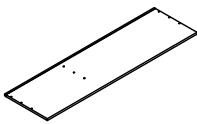
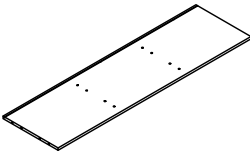
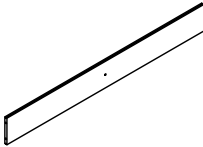
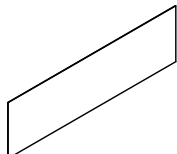
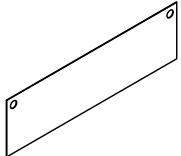
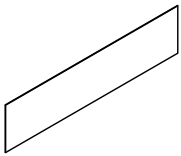
				
① x1pc	③ x1pc	④ x1pc	⑱ x2pcs	⑲ x1pc
				
⑳ x1pc	㉑ x2pcs			

### N620P347798

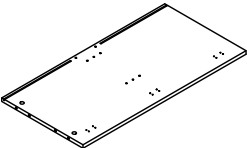
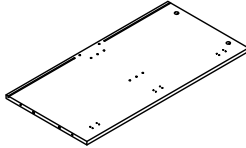
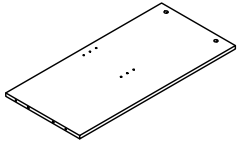
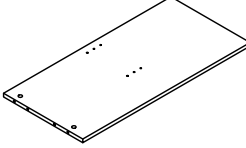
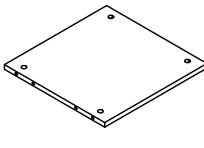
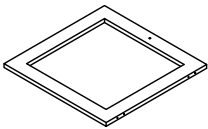
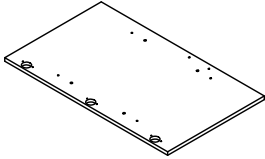
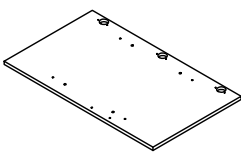
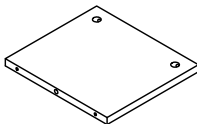



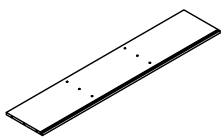
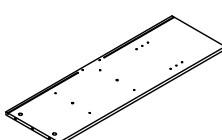
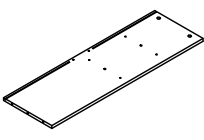
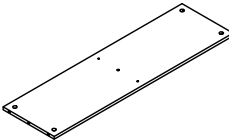
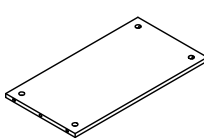
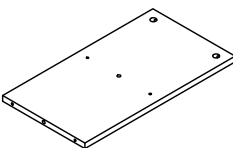
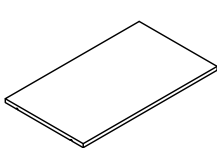
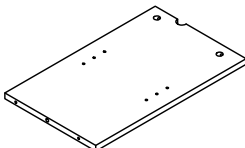
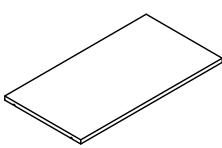
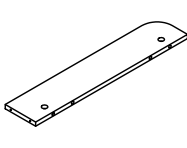
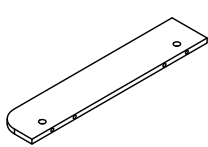
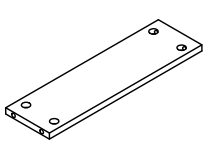
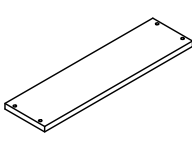
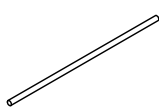
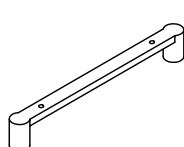
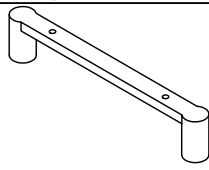





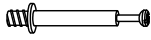

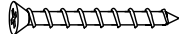

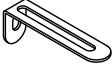



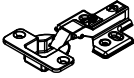

				
⑦ x1pc	⑧ x1pc	⑭ x1pc	⑮ x1pc	⑰ x1pc
				
㉒ x2pcs	㉗ x1pc	㉘ x1pc	㉙ x1pc	

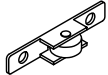
### N620P347799

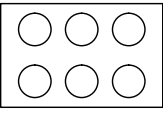
				
② x1pc	⑤ x1pc	⑥ x1pc	⑨ x1pc	⑩ x1pc
				
⑪ x1pc	⑫ x1pc	⑬ x1pc	⑯ x2pcs	㉓ x2pcs
				
㉔ x2pcs	㉕ x2pcs	㉖ x2pcs	⑳ x4pcs	㉑ x1pc
				
㉒ x2pcs				

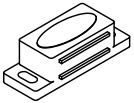

Hardware List  
Hardwareliste

N620P347799

 Ø6x35mm Ⓐx58pcs	 Ø15x9mm Ⓑx58pcs	 Ø8x30mm Ⓒx42pcs	 M4x40mm Ⓓx10pcs	 M3.5x14mm Ⓔx2pcs
 Ø5x14mm Ⓕx12pcs	 Ⓒx2pcs	 M3.5x14mm Ⓗx72pcs	 Ⓙx24pcs	 Ⓜx2pcs
 Ⓚx1pc	 Ⓛx6pcs	 M4x18mm Ⓜx6pcs	 M7x40mm Ⓝx20pcs	 Ⓞx1pc
 Ⓟx2pcs	 Ⓠx4pcs	 M6x25mm Ⓡx6pcs	 Ⓢx4pcs	 Ⓣx58pcs
 Ⓤx2pcs	 Ⓡx2pcs	 Ⓦx1pc	 Ⓧx3pcs	 Ø8x50mm Ⓨx1pcs
 Ⓩx2pcs				

# Step 1

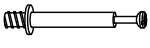
## Schritt 1

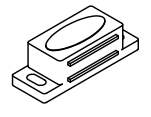
	
Ø6x35mm	M3.5x14mm
Ⓐx36pcs	Ⓗx4pcs
	
	Ⓒx2pcs

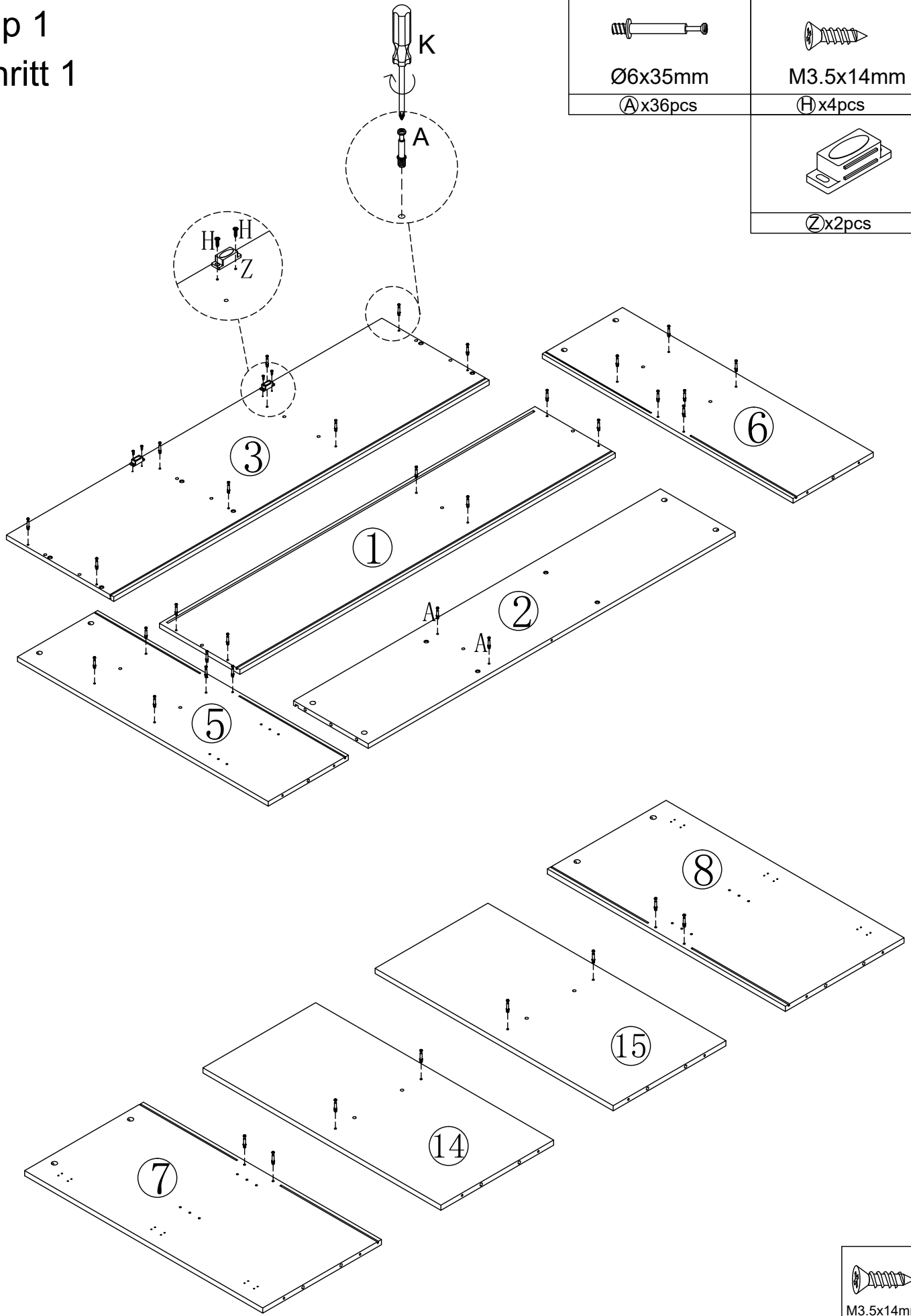

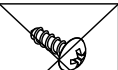
M3.5x14mm

<del>M3.5x14mm</del>

# Step 2

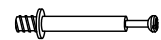
## Schritt 2



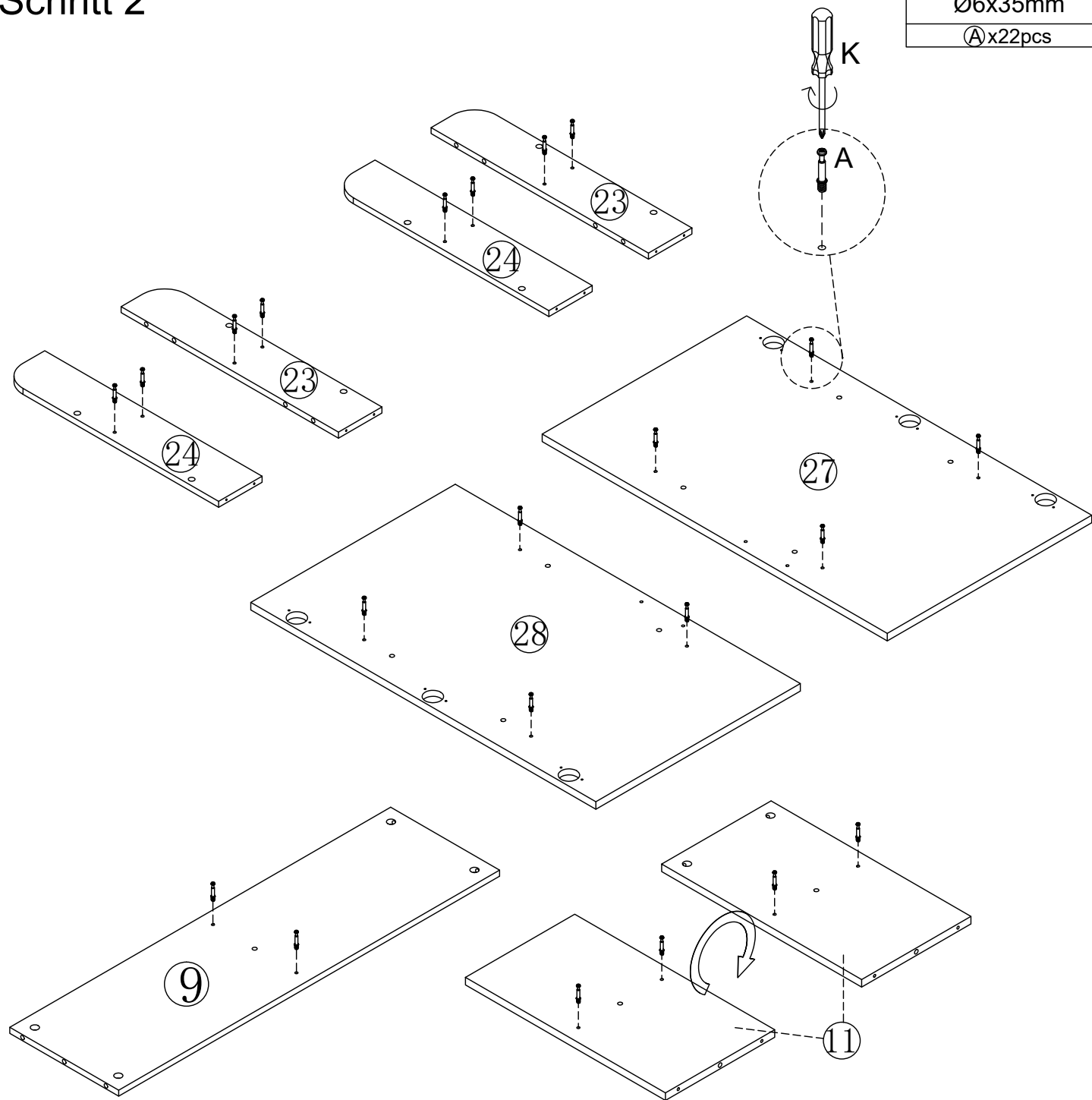

Ø6x35mm

Ⓐx22pcs



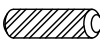

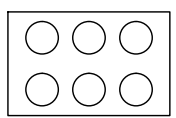
# Step 3 Schritt 3

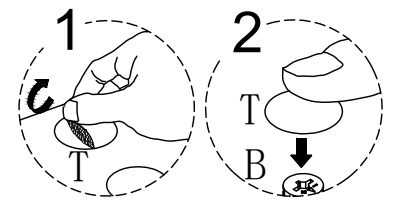
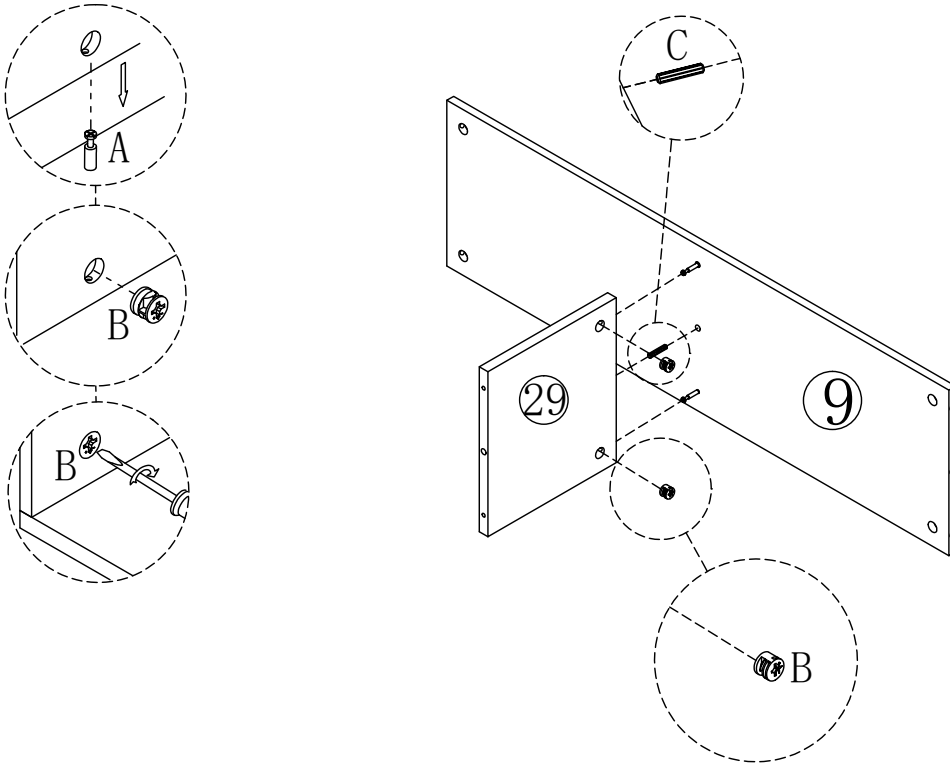
	
Ø8x30mm	Ø15x9mm
Ⓒx1pc	Ⓑx2pcs
	
	Ⓓx2pcs



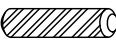
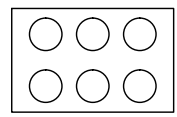

# Step 4 Schritt 4

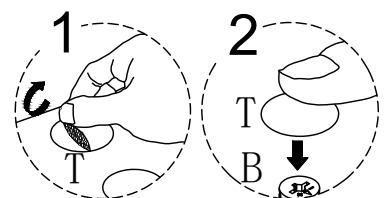
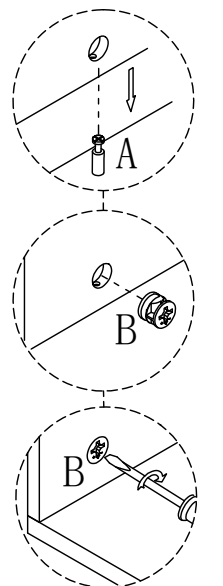
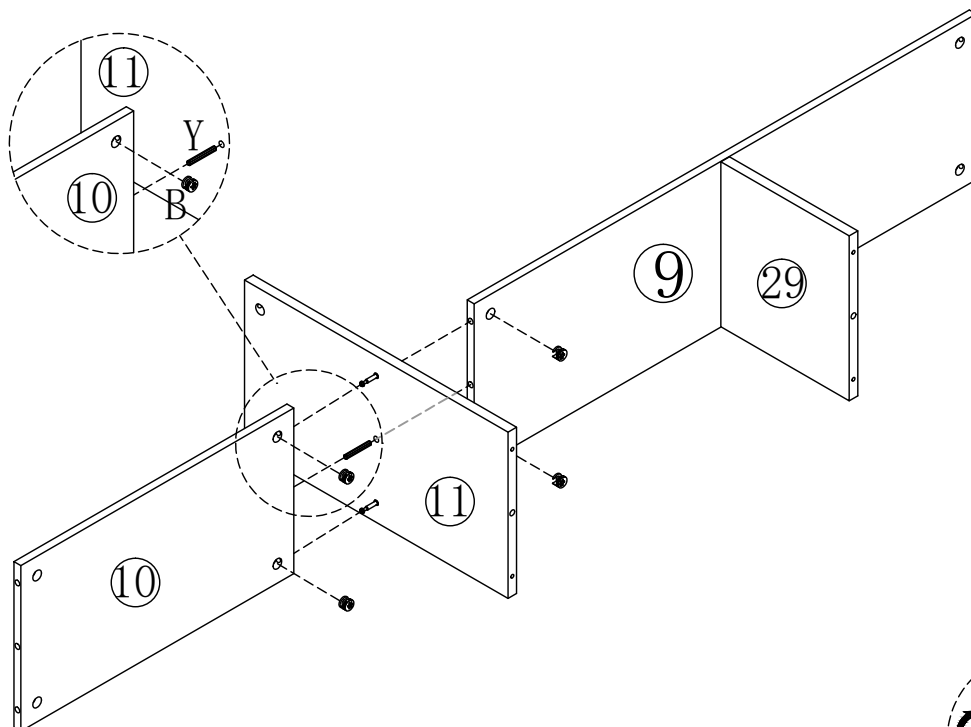
		
Ø8x50mm		Ø15x9mm
Ⓐx1pcs	Ⓒx4pcs	Ⓑx4pcs



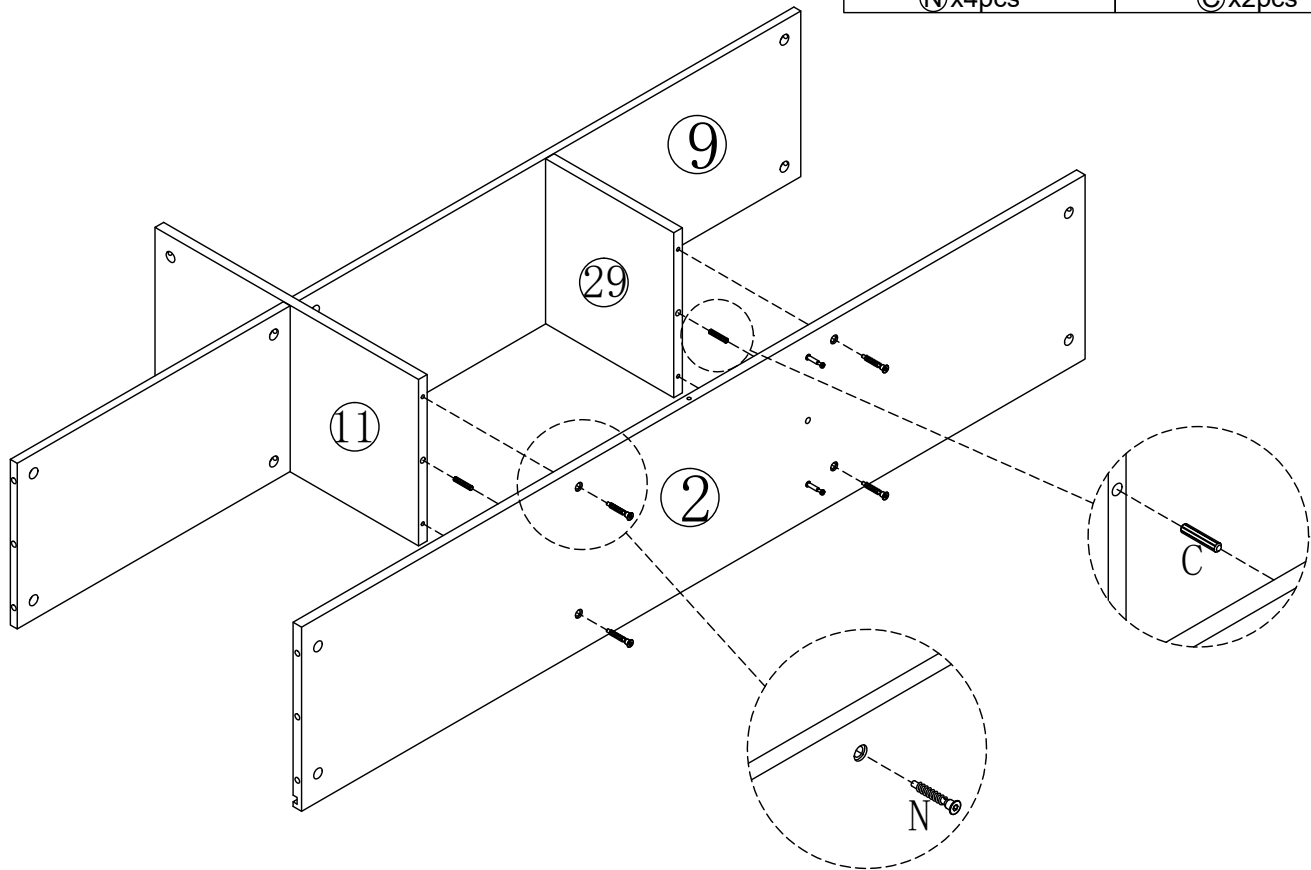

# Step 5 Schritt 5

	
M7x40mm	Ø8x30mm
Ⓝx4pcs	Ⓒx2pcs



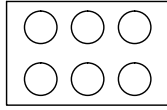

# Step 6 Schritt 6

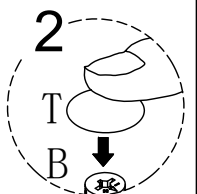
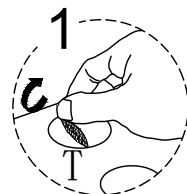
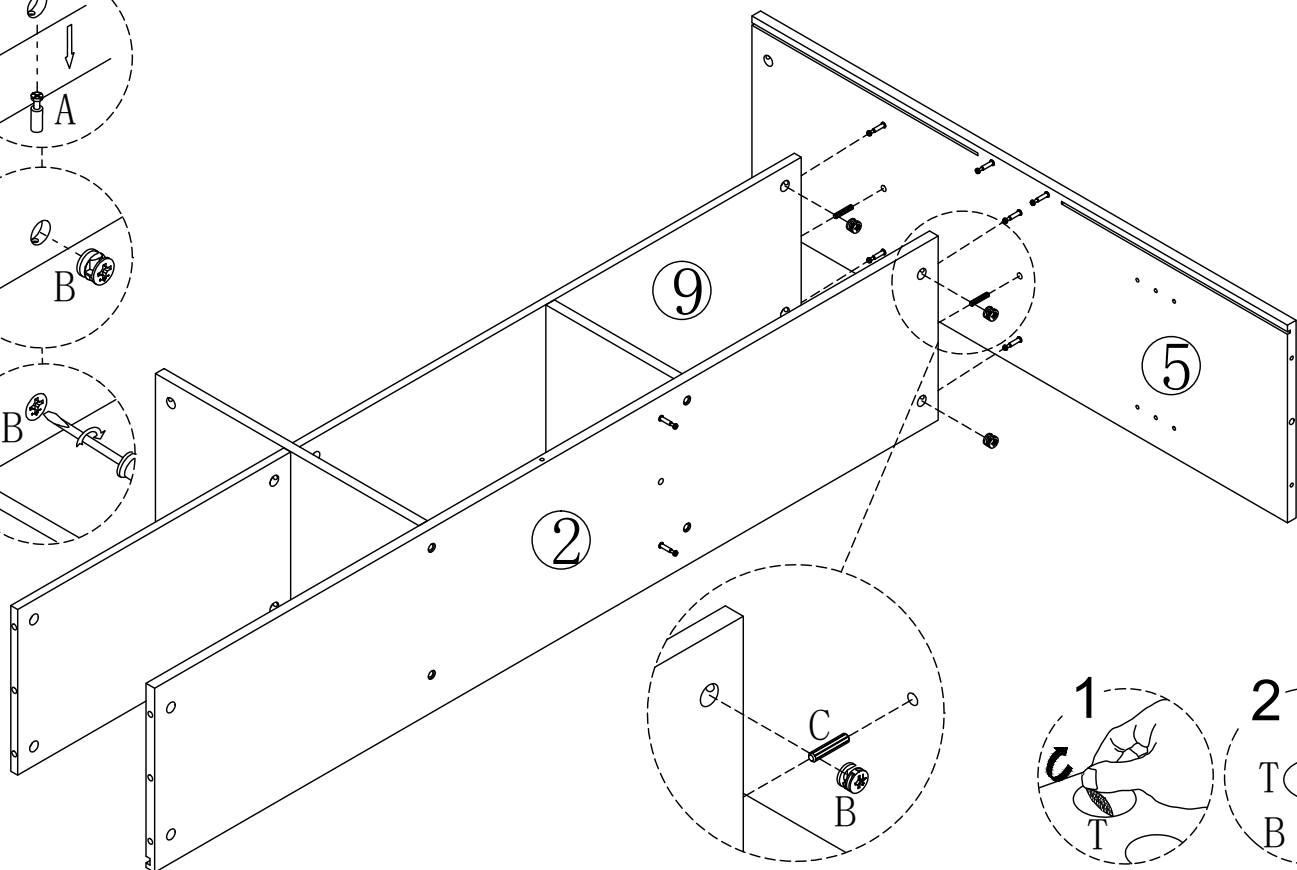
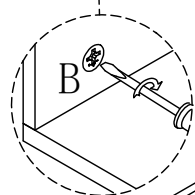
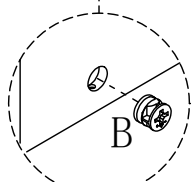
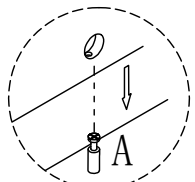
		
Ø8x30mm		Ø15x9mm
Ⓒx2pcs	Ⓣx4pcs	Ⓑx4pcs



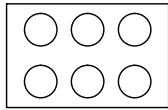

# Step 7 Schritt 7

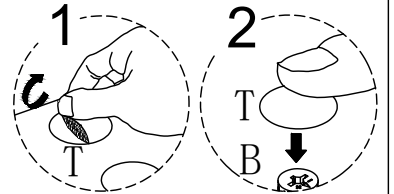
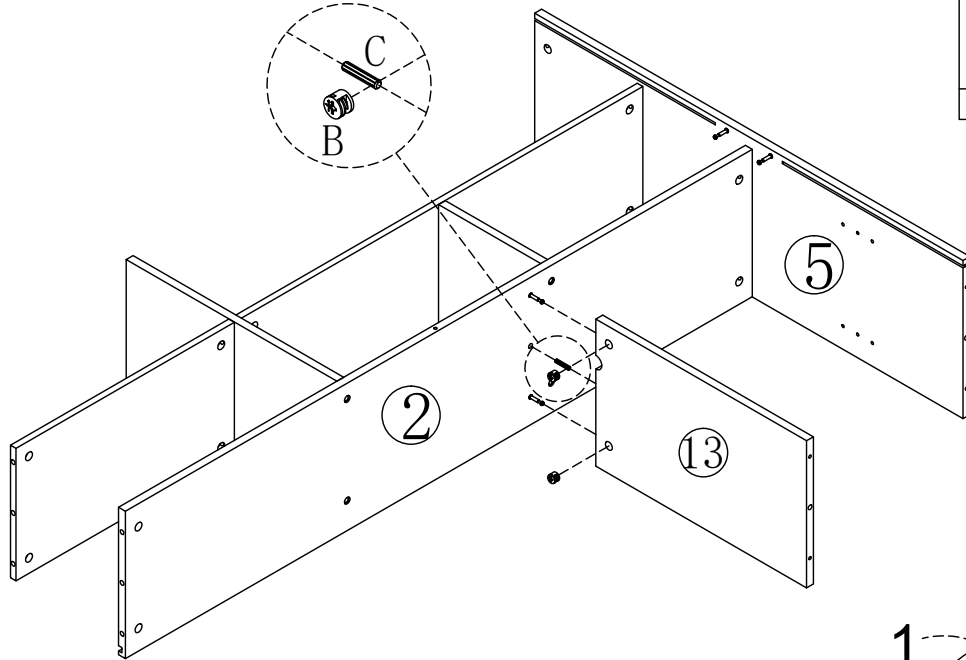
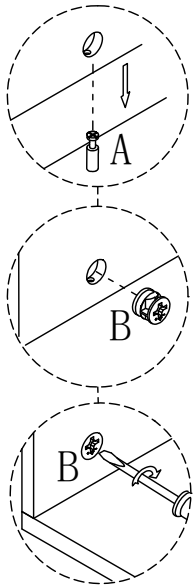
	
Ⓐx2pcs	Ⓑx2pcs Ø15x9mm
	
	Ⓒx1pcs Ø8x30mm



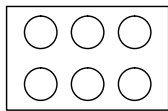

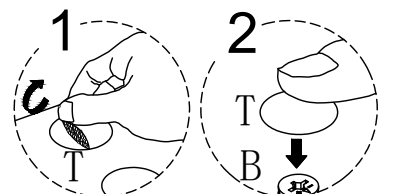
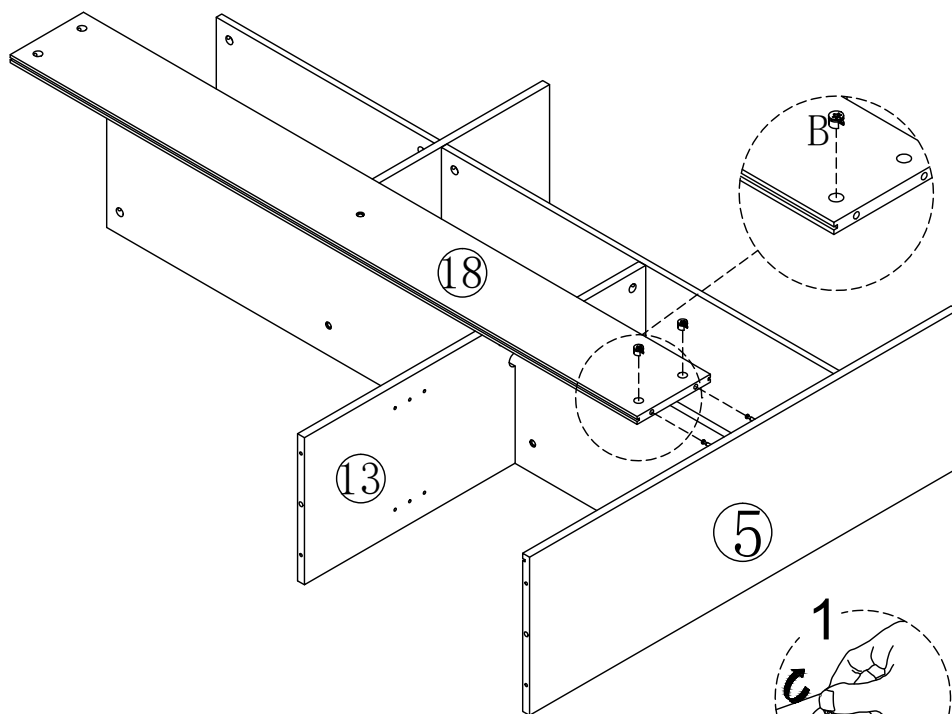
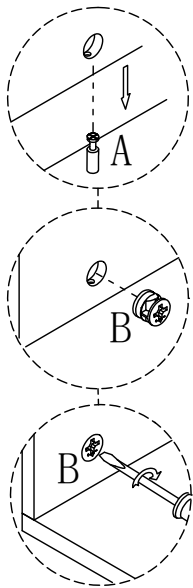

# Step 8 Schritt 8

	
Ⓐx2pcs	Ⓑx2pcs Ø15x9mm

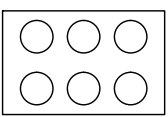

# Step 9 Schritt 9

			
M7x40mm	Ø8x30mm		Ø15x9mm
Nx1pc	Cx2pcs	Tx6pcs	Bx6pcs

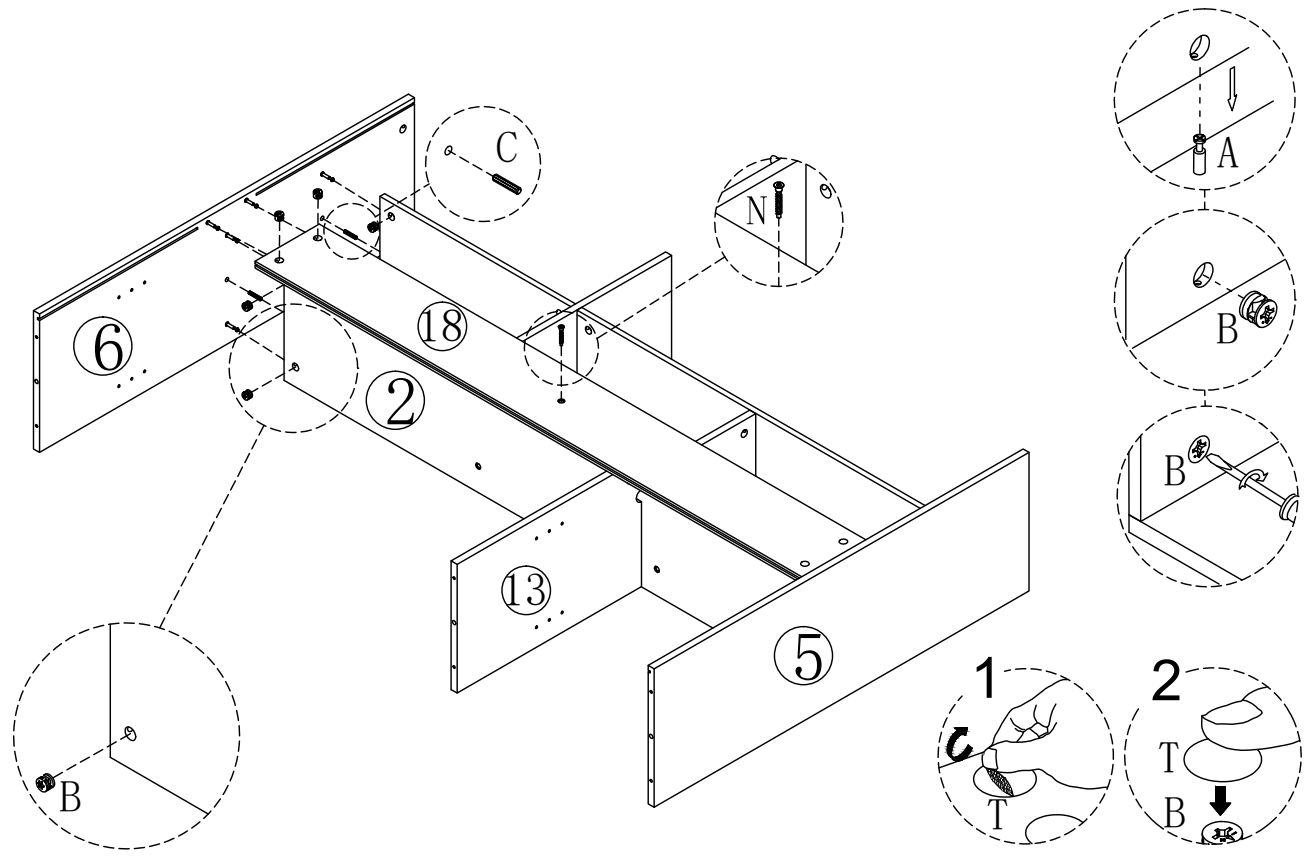

# Step 10 Schritt 10

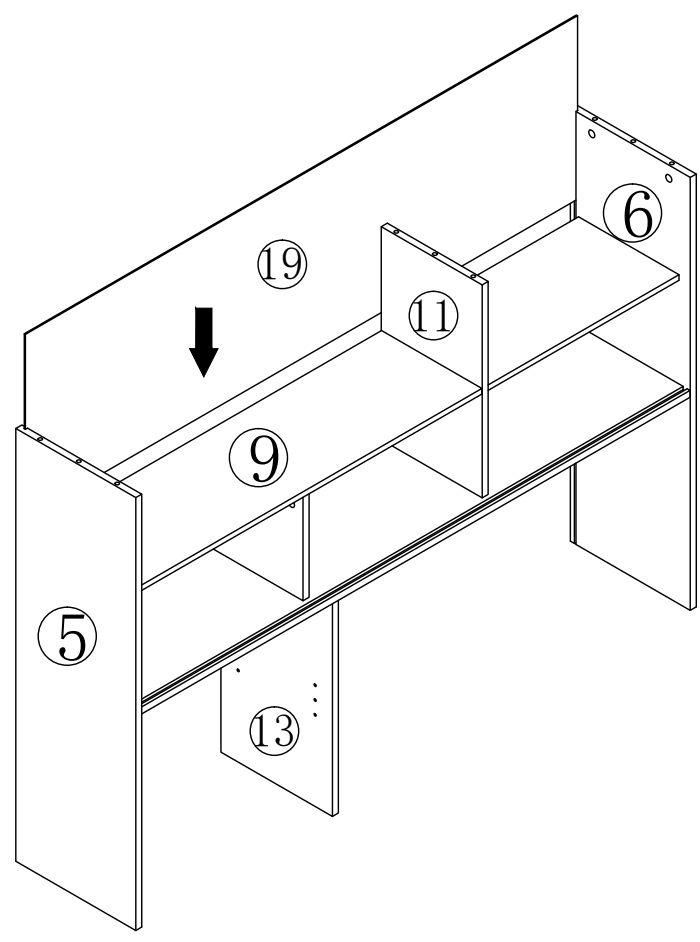

Step 11  
Schritt 11

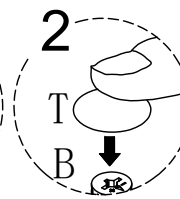
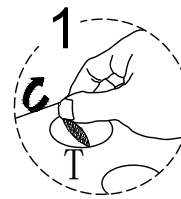
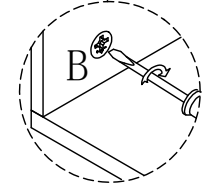
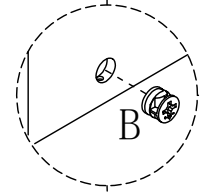
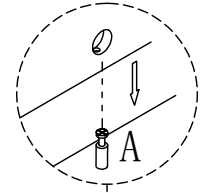
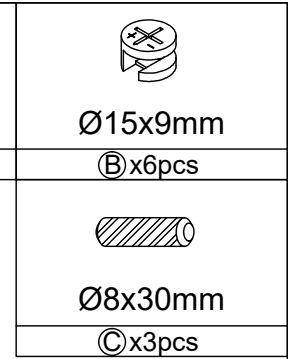
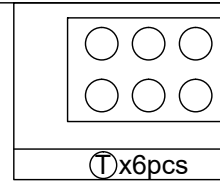
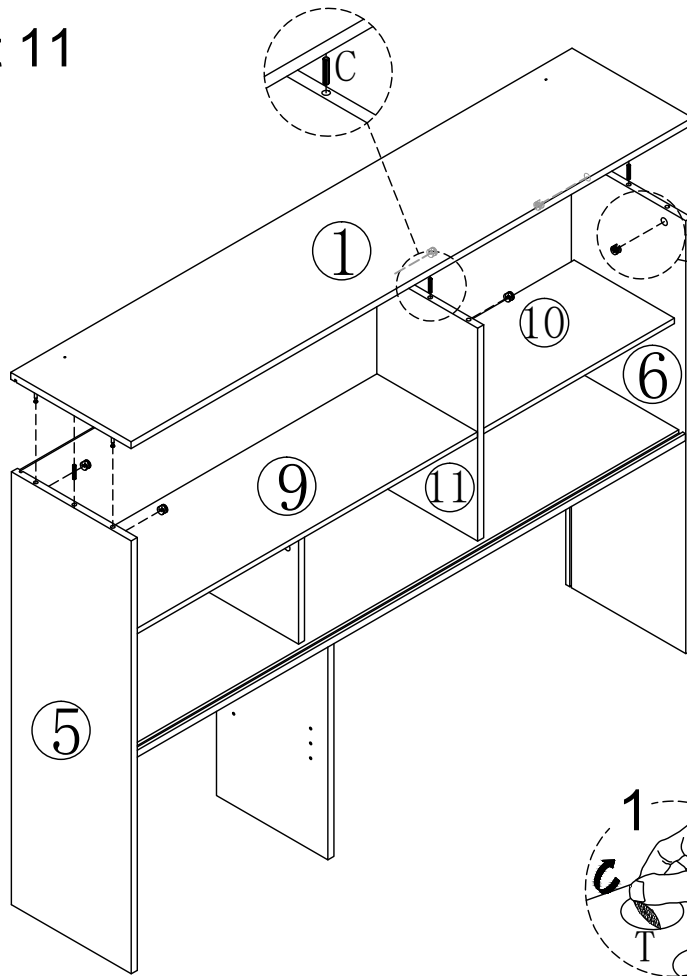

Step 12  
Schritt 12

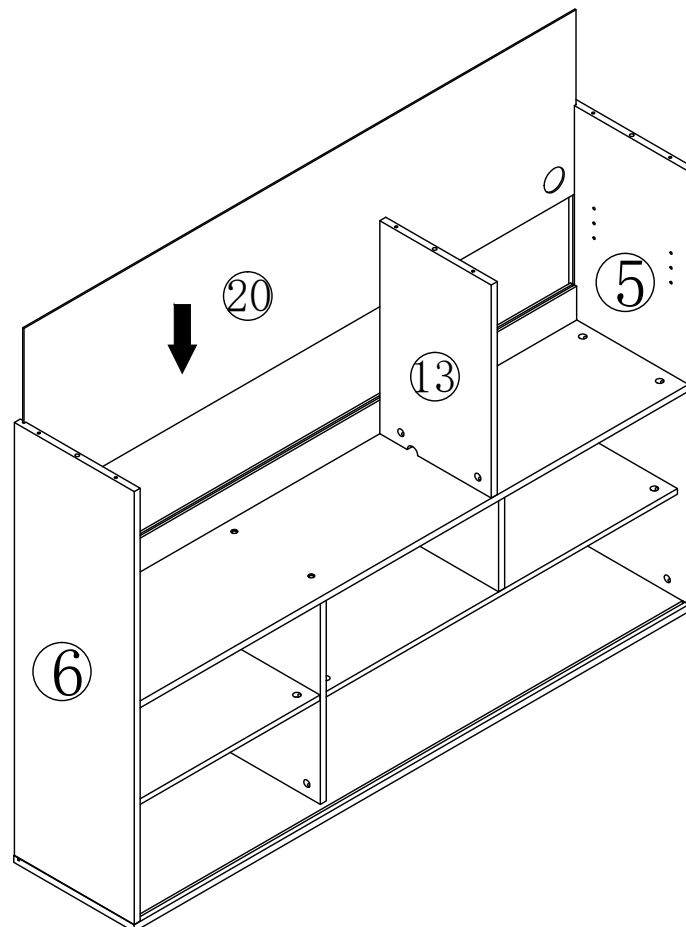

Step 13  
Schritt 13

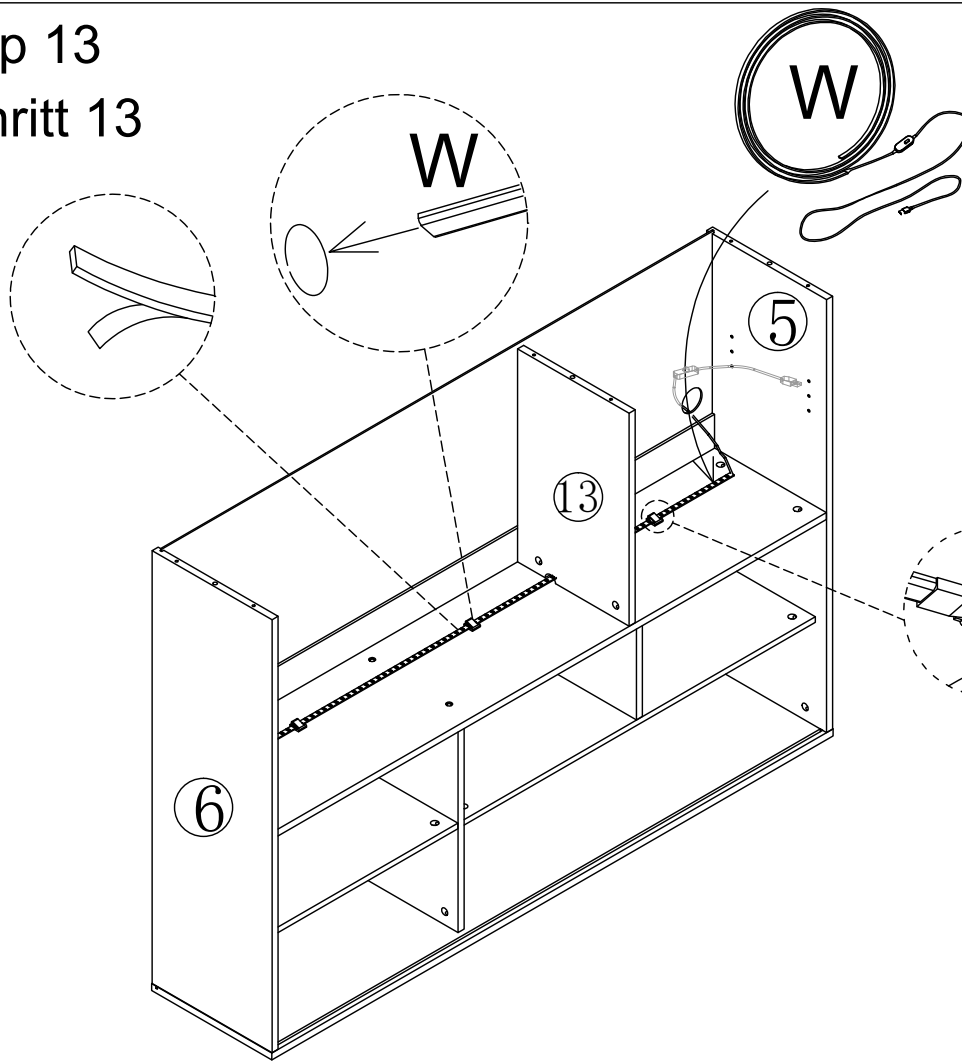

W x1pc



X x3pcs

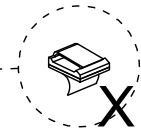
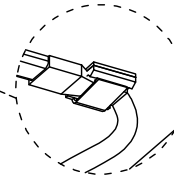

Step 14  
Schritt 14

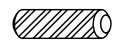
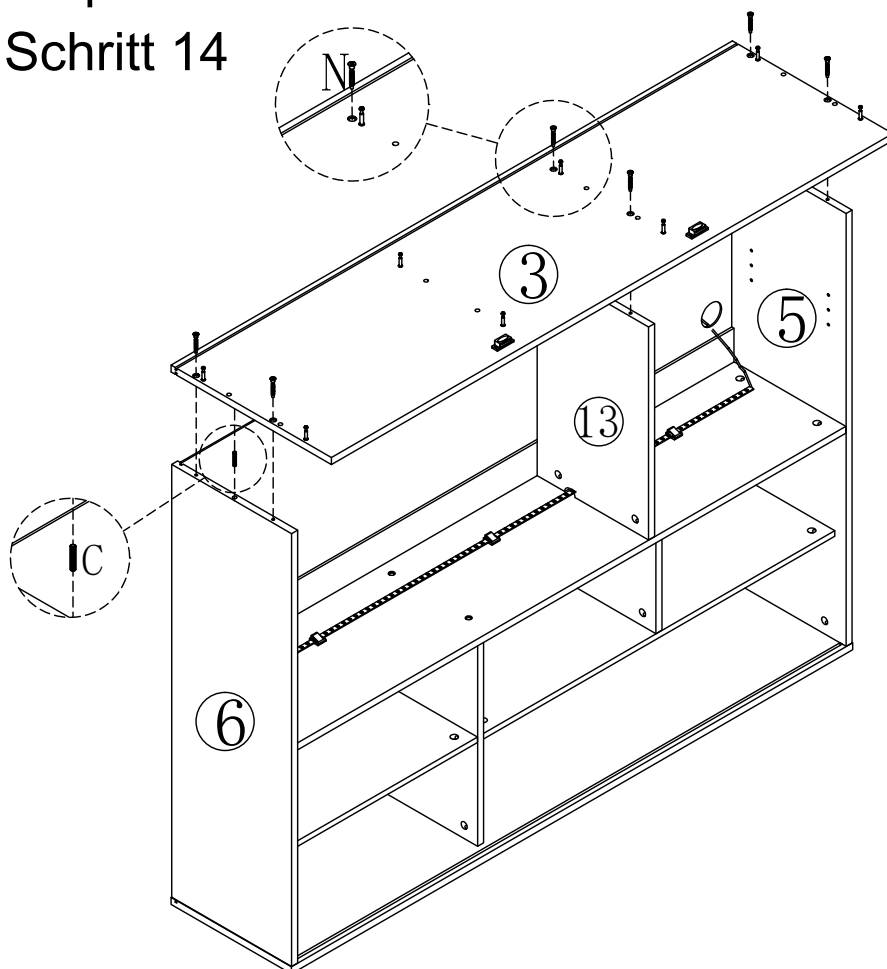

Ø8x30mm

C x3pcs



M7x40mm

N x6pcs

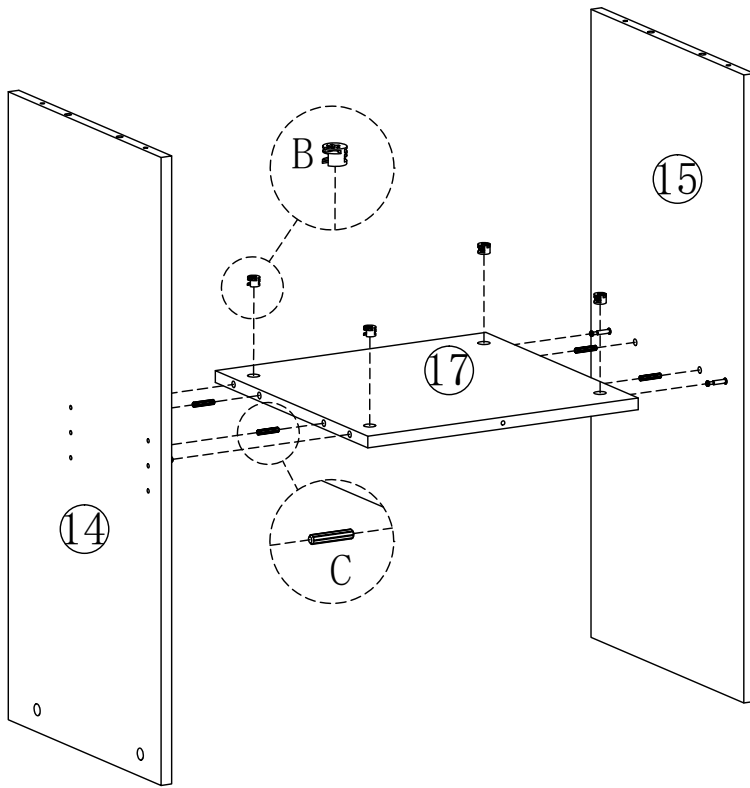
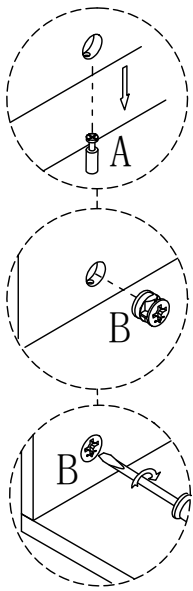

# Step 15 Schritt 15

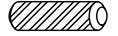
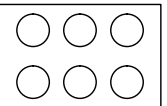

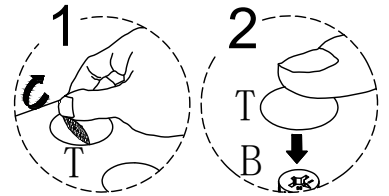

Ø15x9mm
ⓑx4pcs

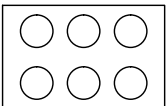
Ø8x30mm
ⓒx4pcs

Ⓣx4pcs

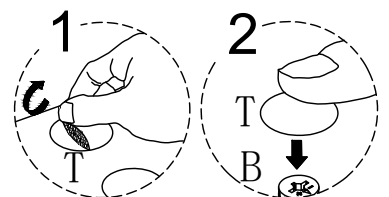
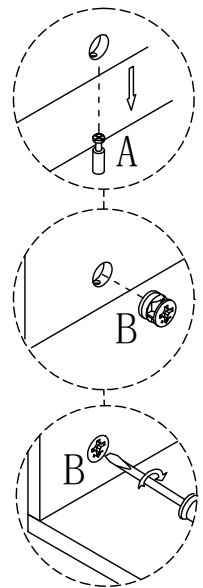
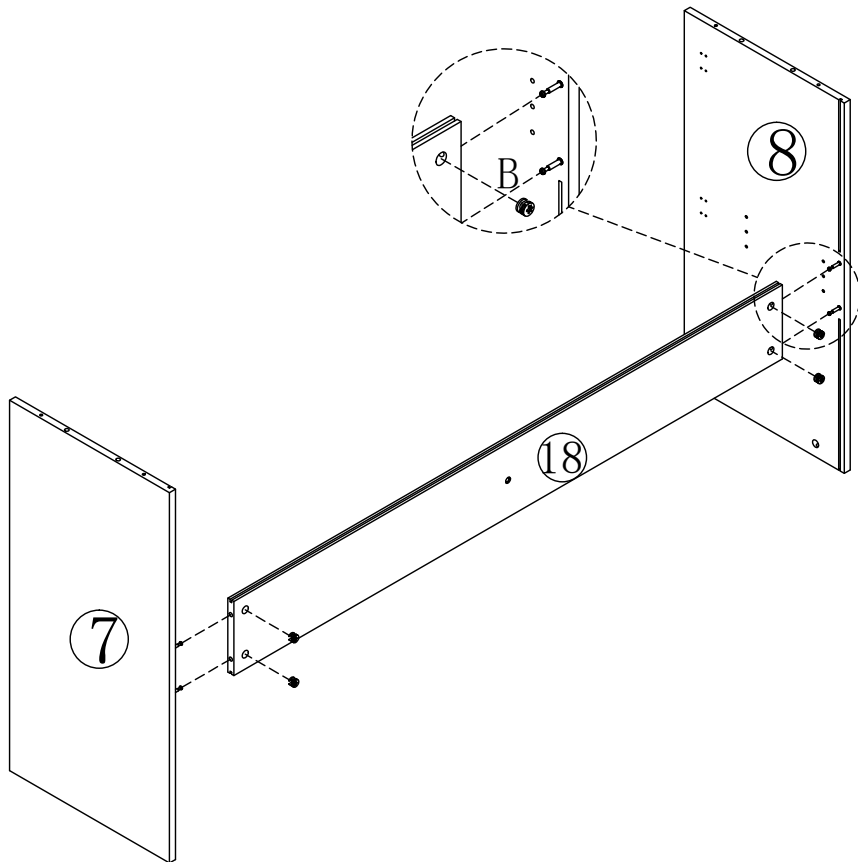

# Step 16 Schritt 16

	
Ⓣx4pcs	Ø15x9mm
	ⓑx4pcs



Step 17  
Schritt 17



M7x40mm

Ⓝx1pc

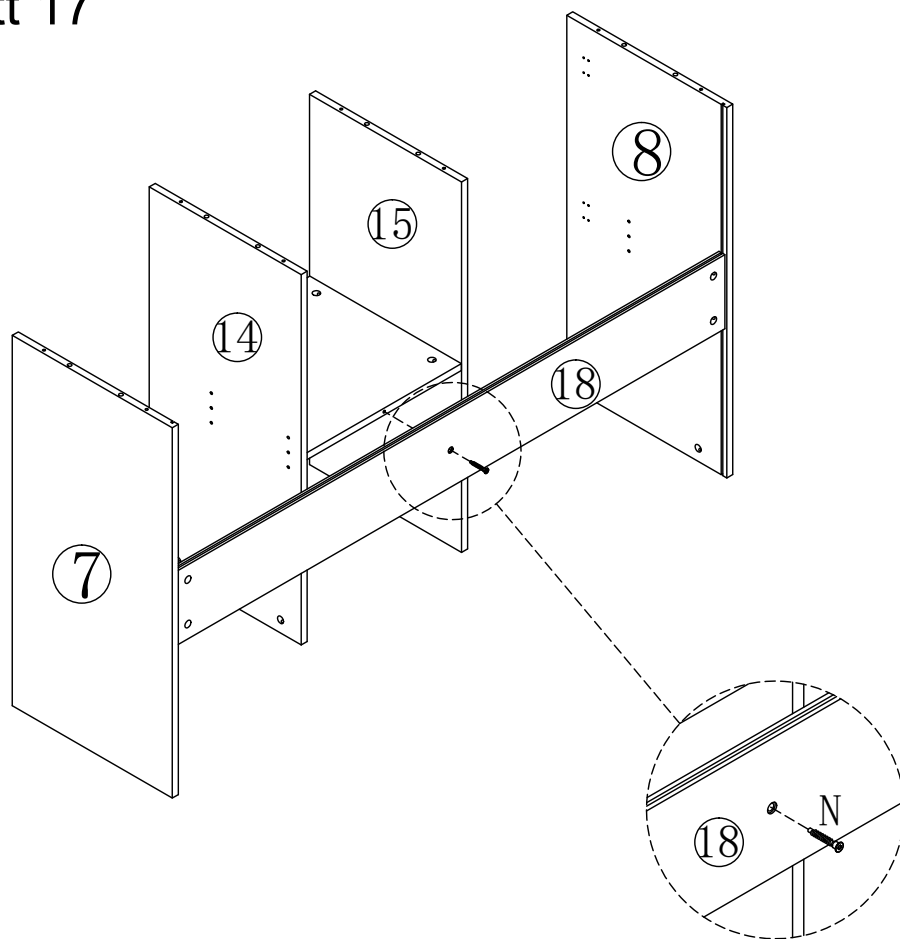

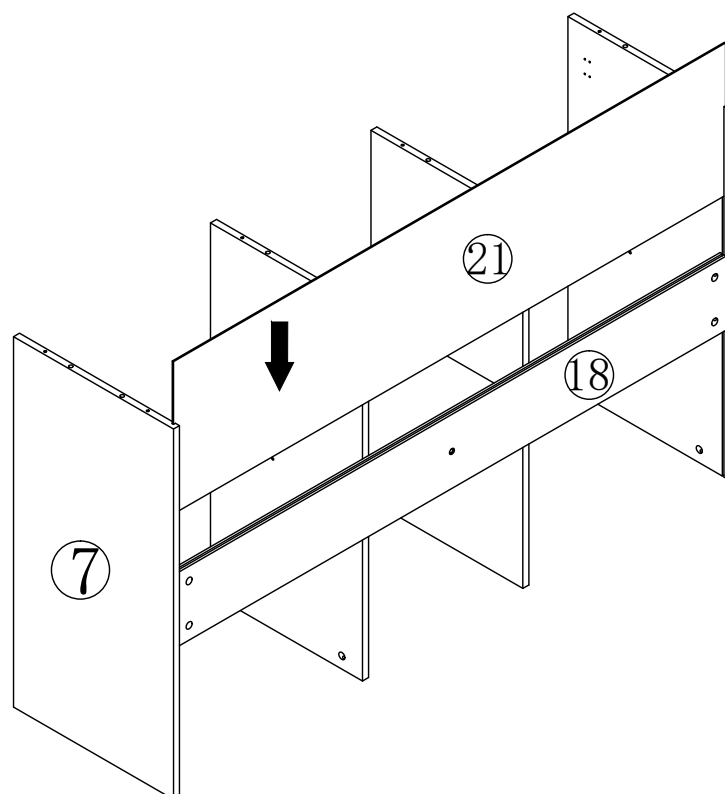

Step 18  
Schritt 18

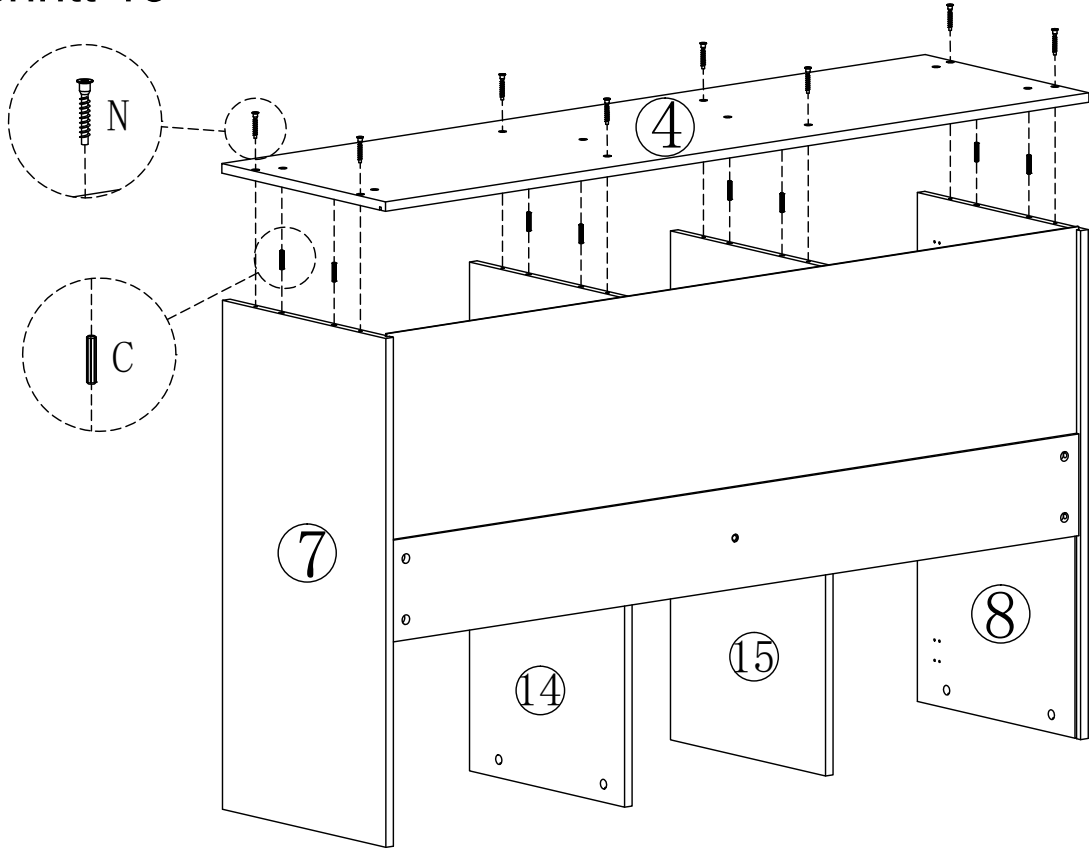

Step 19  
Schritt 19



Ø8x30mm
Ⓢx8pcs

M7x40mm
Ⓝx8pcs

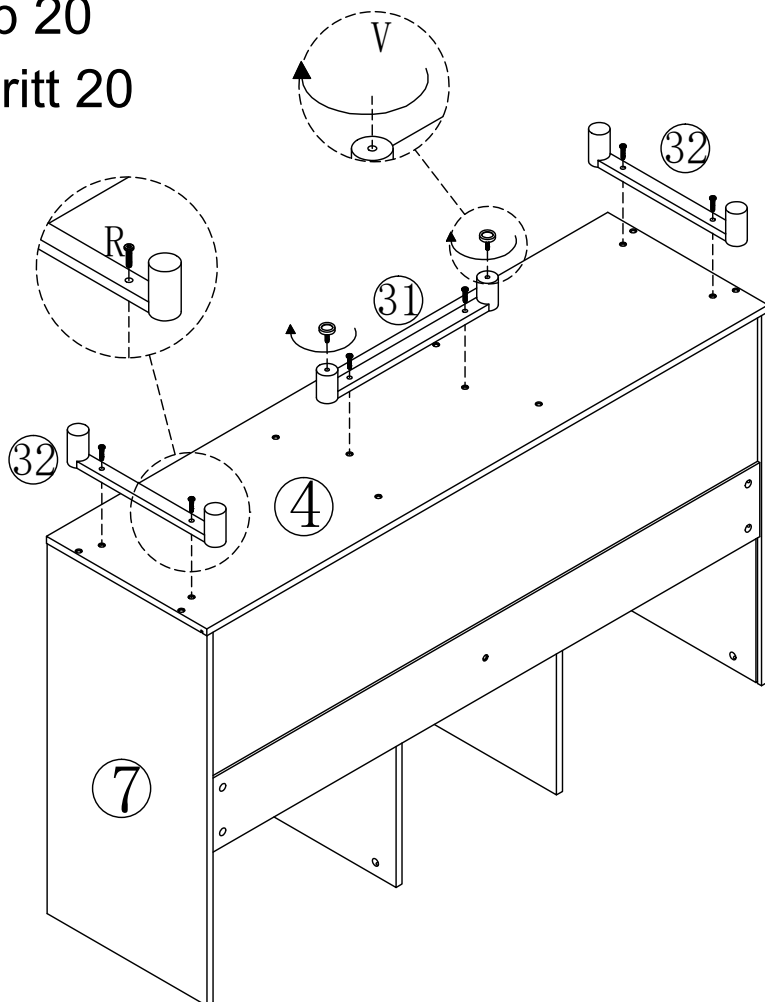
Step 20  
Schritt 20



	
Ⓥx2pcs	M6x25mm
	Ⓡx6pcs

Step 21

Schritt 21

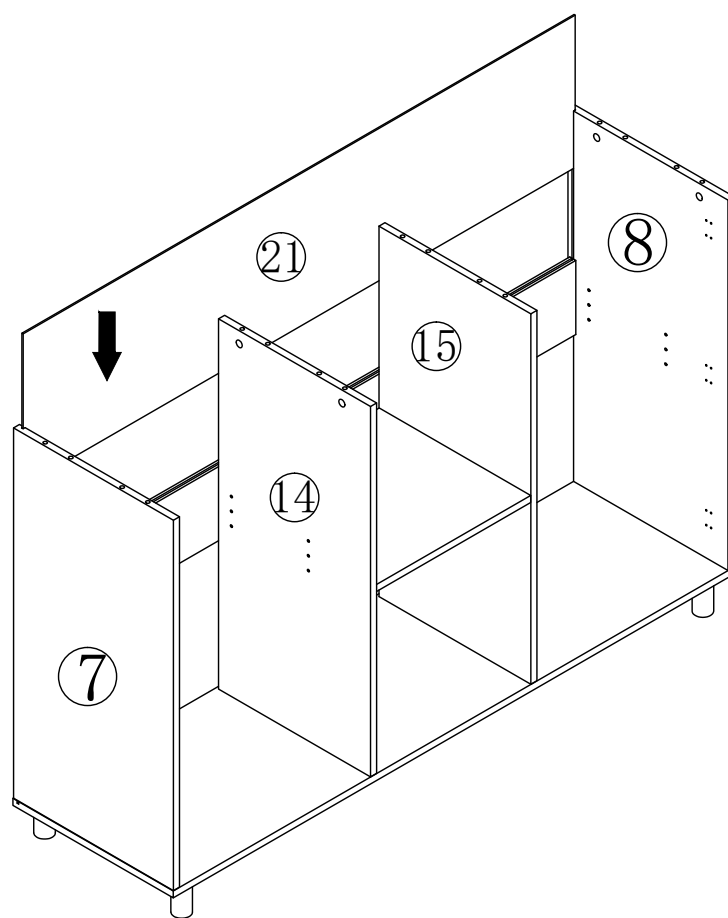

# Step 22

## Schritt 22



Ø15x9mm

ⓑx8pcs

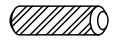

Ø8x30mm

ⓒx8pcs

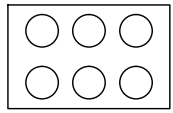

ⓓx8pcs

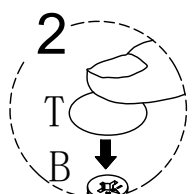
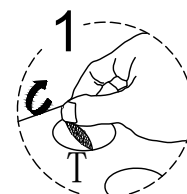
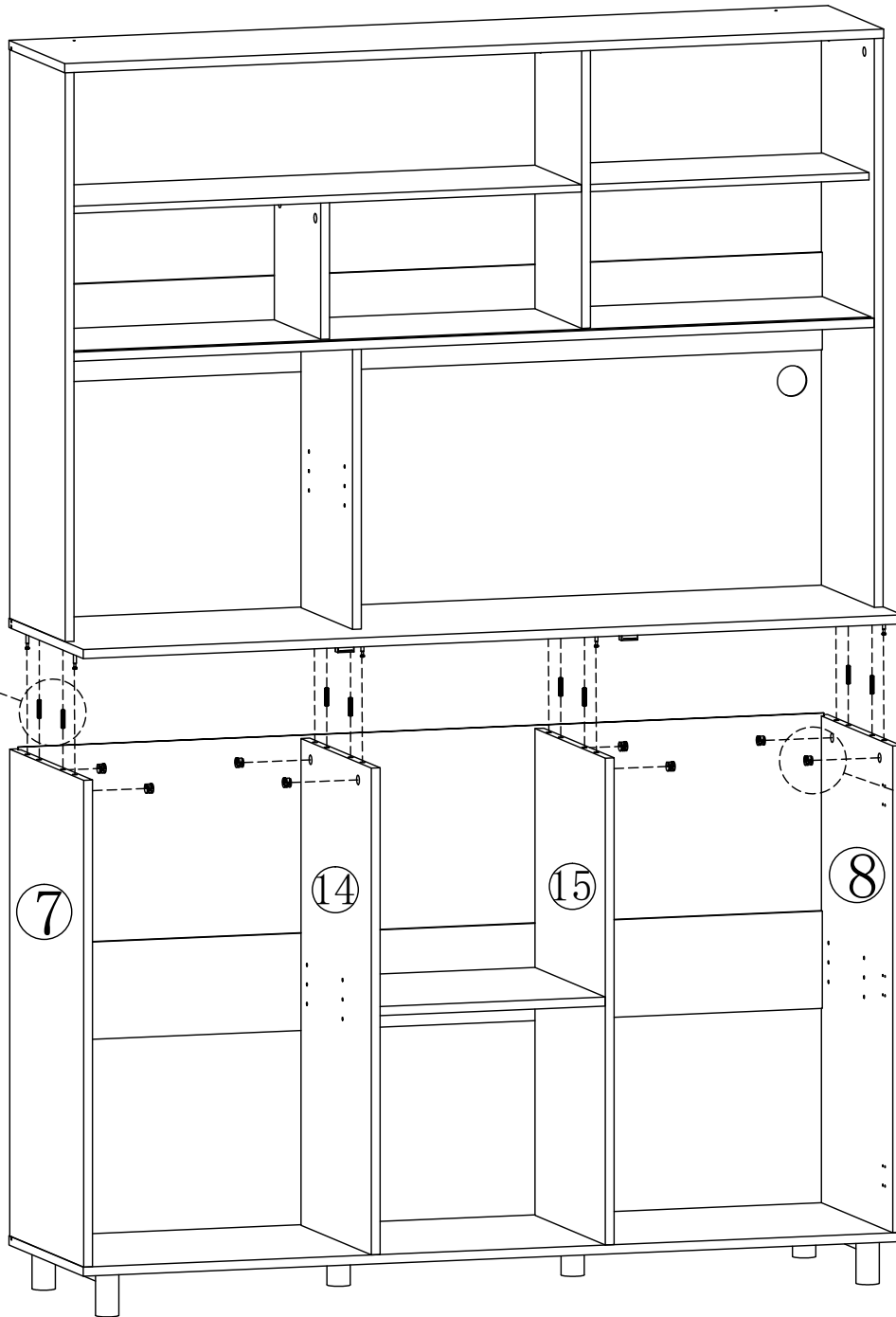
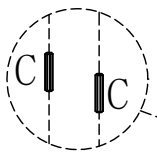
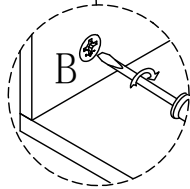
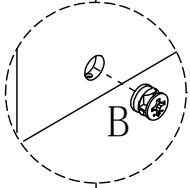
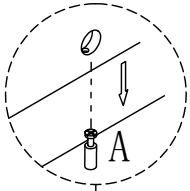

# Step 23

## Schritt 23



M3.5x14mm

Ⓜ x24pcs



① x24pcs

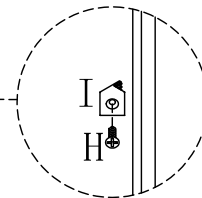
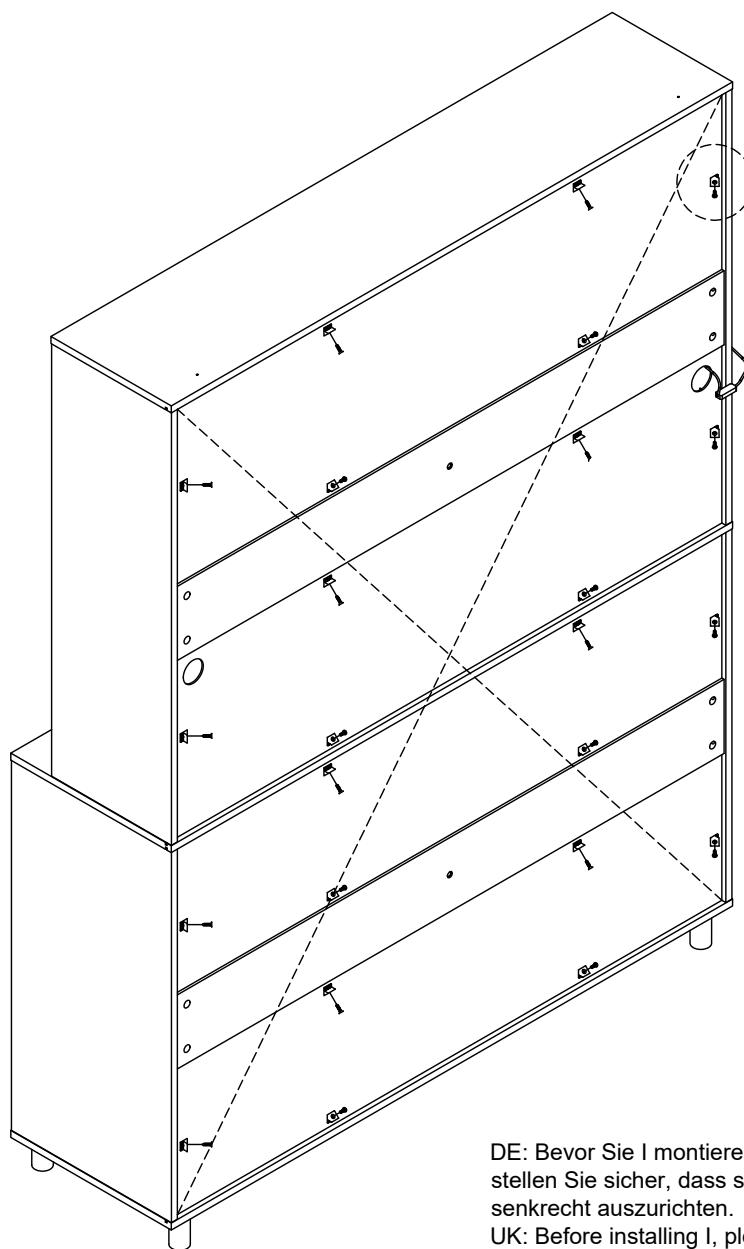

DE: Bevor Sie I montieren, messen Sie bitte die Diagonalen und stellen Sie sicher, dass sie gleich lang sind, um den Schrank senkrecht auszurichten.

UK: Before installing I, please measure the diagonals to ensure they are equal in length, keeping the cabinet upright.

FR: Avant d'installer I, veuillez mesurer les diagonales et vous assurer qu'elles sont de même longueur afin de maintenir l'armoire droite.

IT: Prima di installare I, misurare le diagonali e assicurarsi che siano della stessa lunghezza per mantenere l'armadio in posizione verticale.

ES: Antes de instalar I, mida las diagonales y asegúrese de que tengan la misma longitud para mantener el armario en posición vertical.

NL: Voordat u I installeert, meet de diagonalen en zorg ervoor dat ze even lang zijn om de kast rechtop te houden.

SE: Innan du installerar I, mät diagonalerna och se till att de är lika långa för att hålla skåpet upprätt.

PL: Przed zamontowaniem I zmierz przekątne i upewnij się, że są równej długości, aby szafa była pionowa.



M3.5x14mm

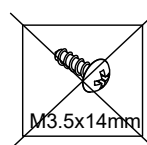

M3.5x14mm

Step 24  
Schritt 24



Ø5x14mm

Ⓡx12pcs

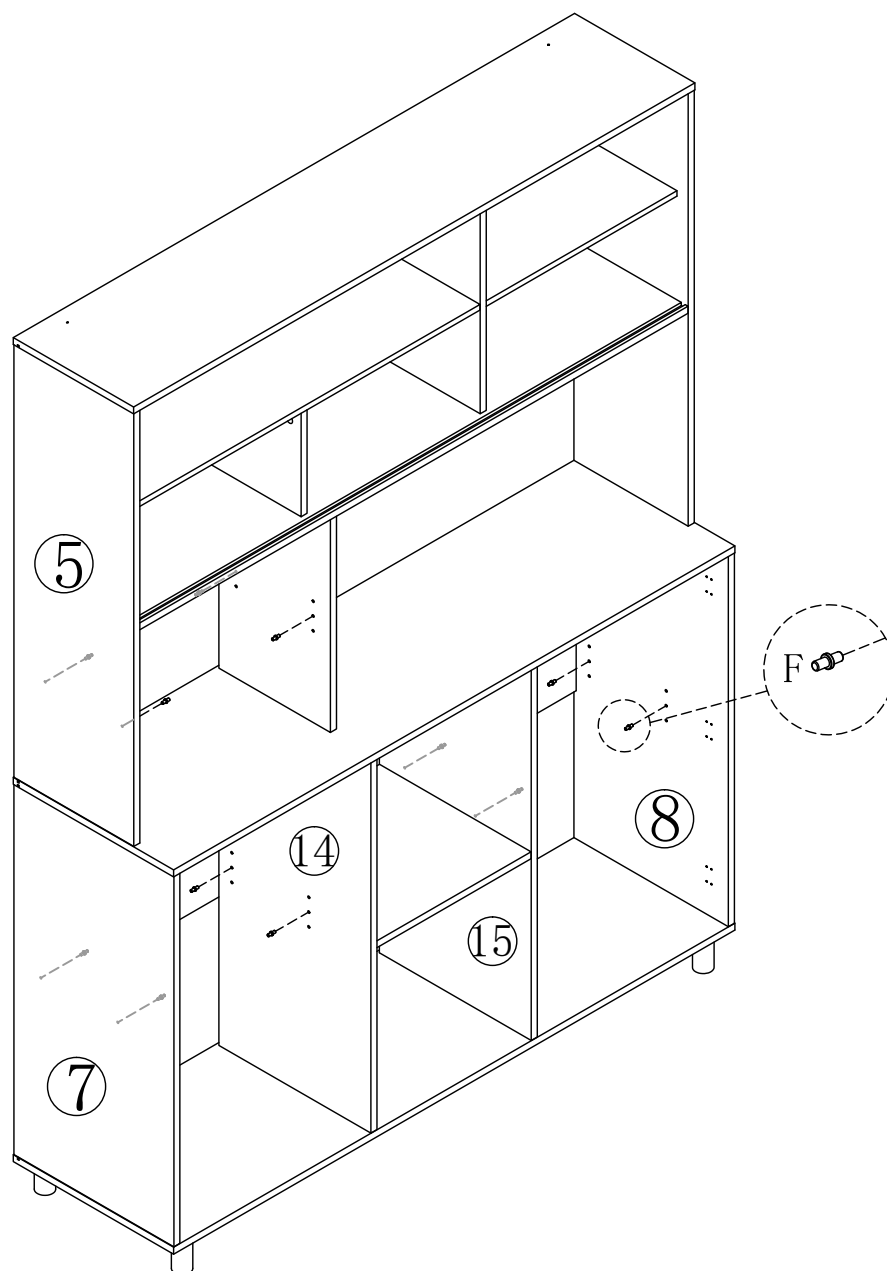

Step 25  
Schritt 25

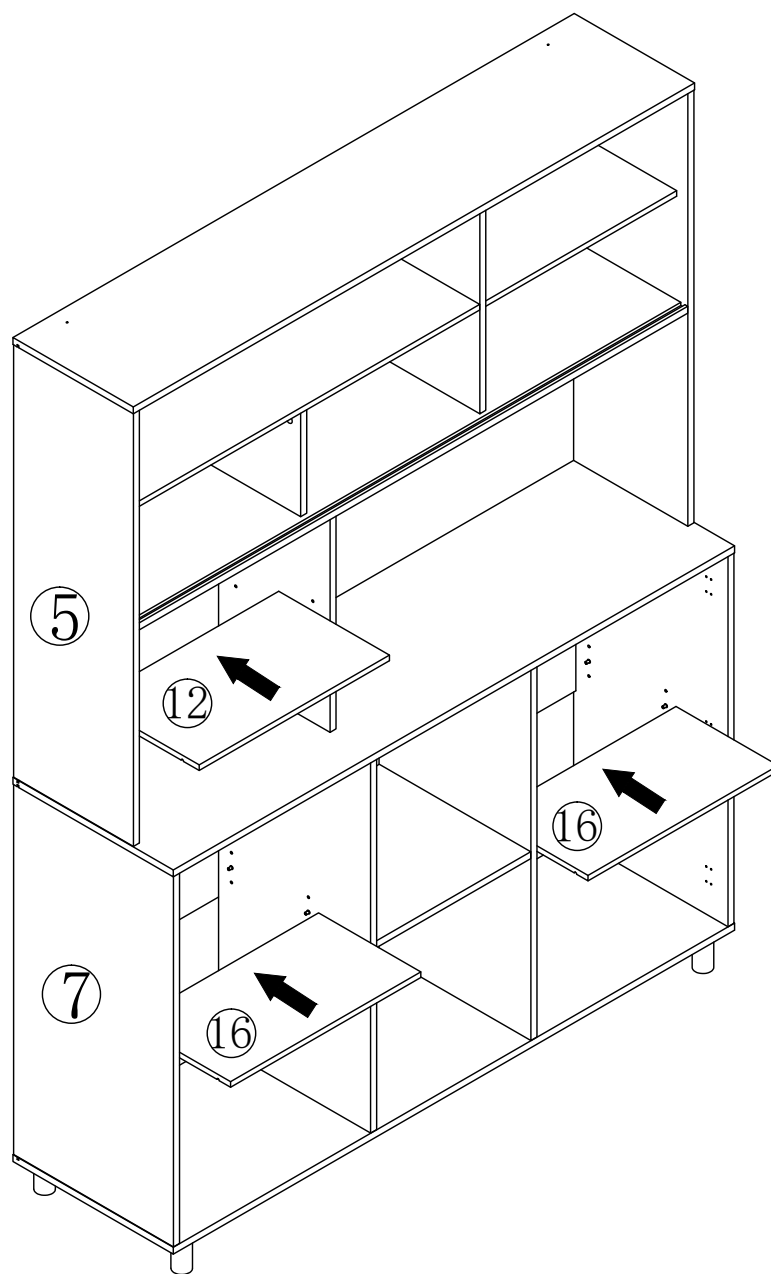

# Step 26 Schritt 26

①x4pcs	②x4pcs

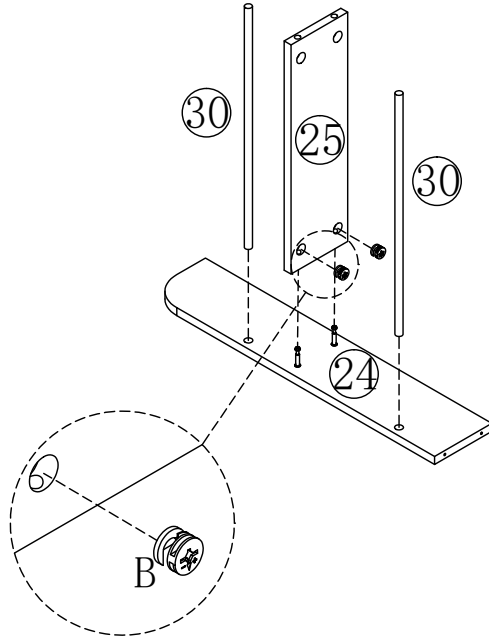
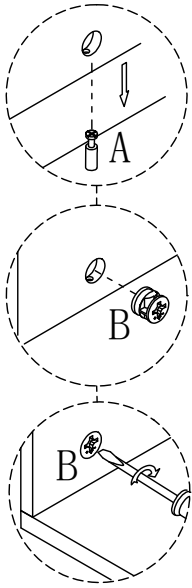

x2

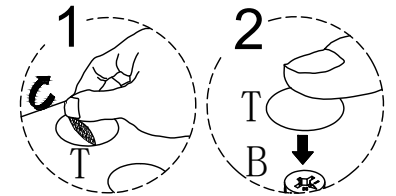

# Step 27 Schritt 27

①x4pcs	②x4pcs

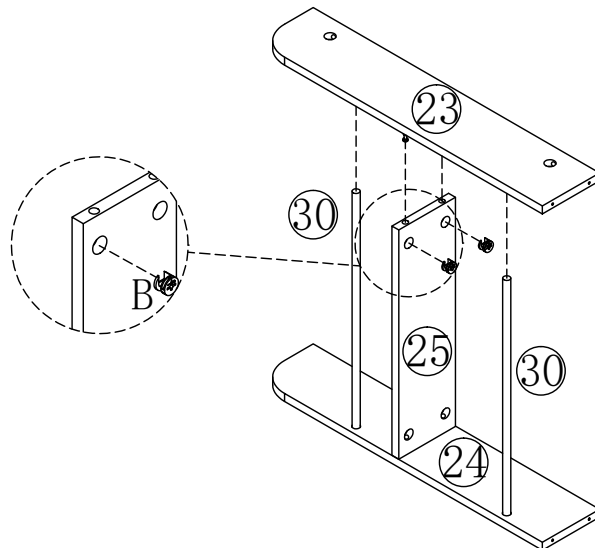
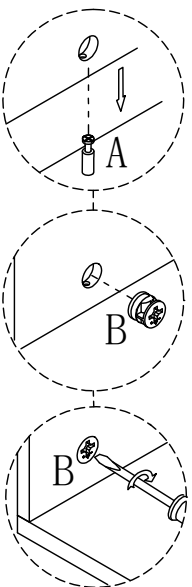

x2

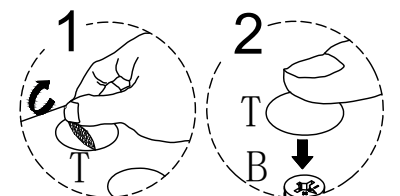

# Step 28

## Schritt 28

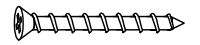

M4x40mm

ⓓx8pcs

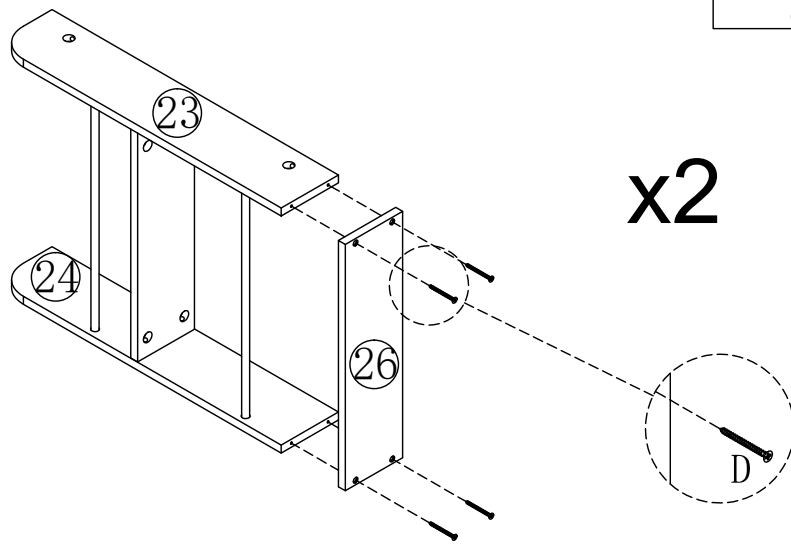

# Step 29

## Schritt 29

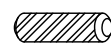

Ø8x30mm

Ⓒx8pcs

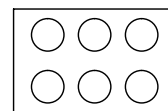

Ⓣx8pcs



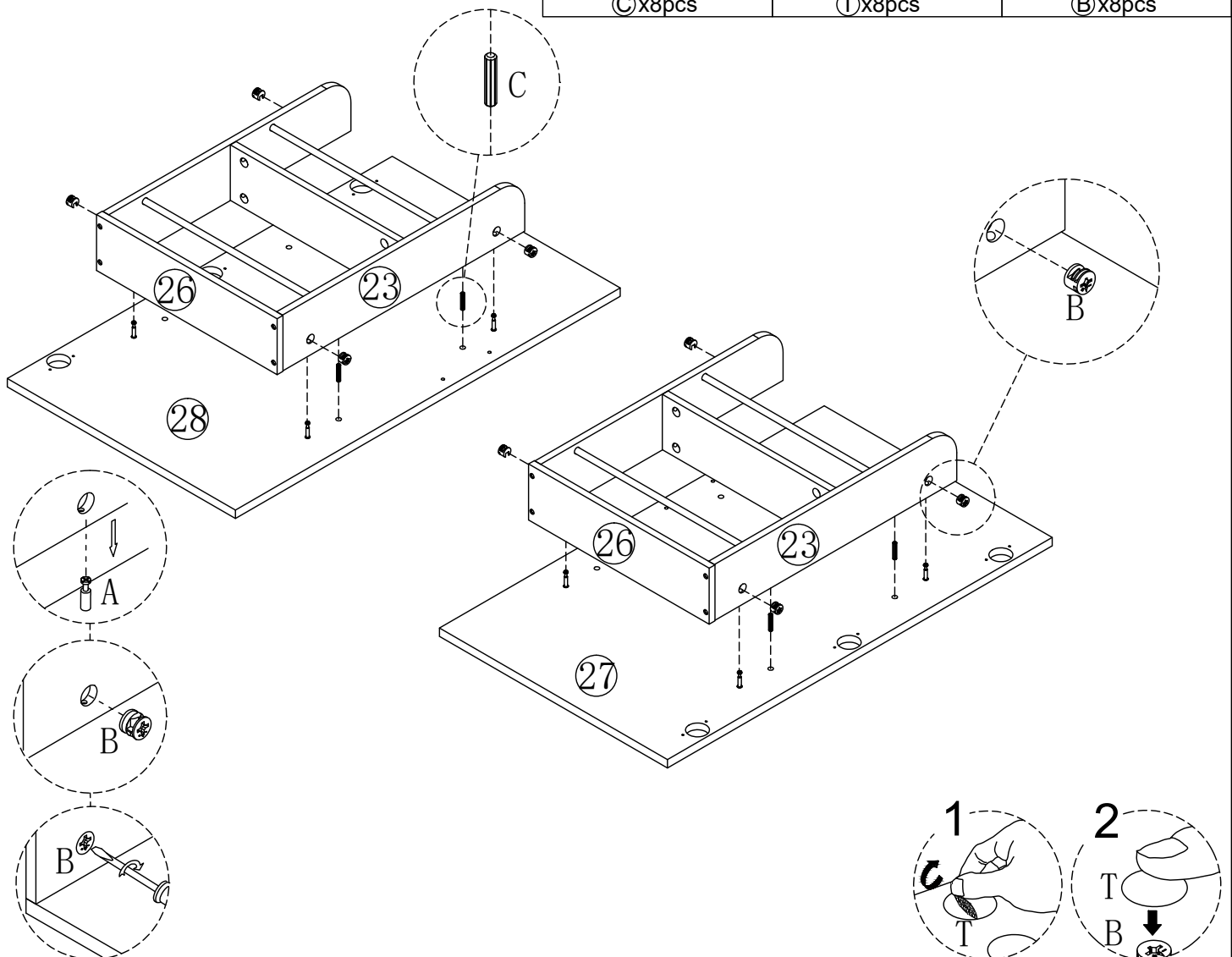

Ø15x9mm

Ⓑx8pcs



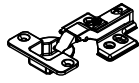

# Step 30 Schritt 30

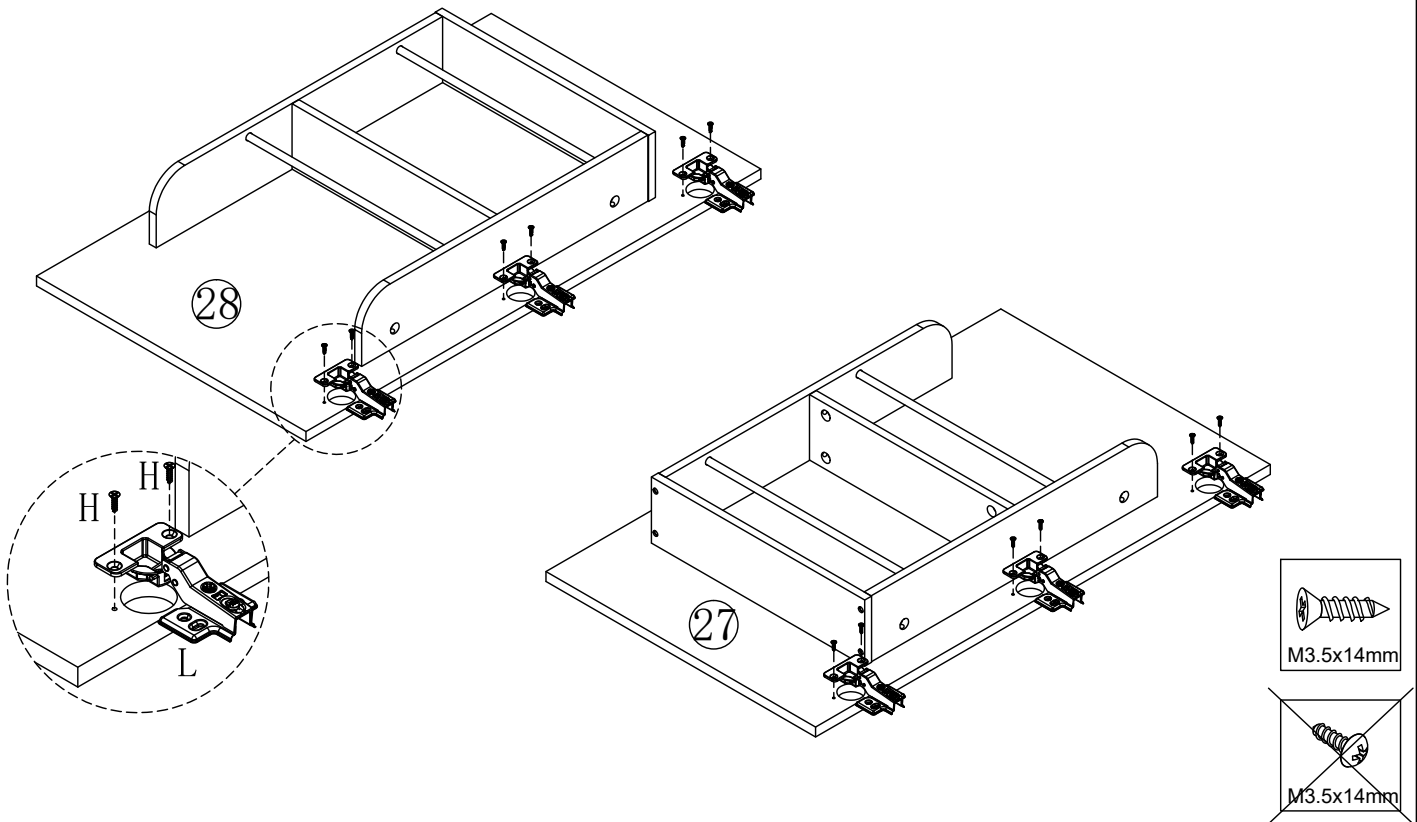
	
Ⓛx6pcs	Ⓜ3.5x14mm Ⓜx12pcs

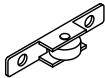

# Step 31 Schritt 31

		
Ⓢx4pcs	Ⓚx4pcs	Ⓜ3.5x14mm Ⓜx8pcs

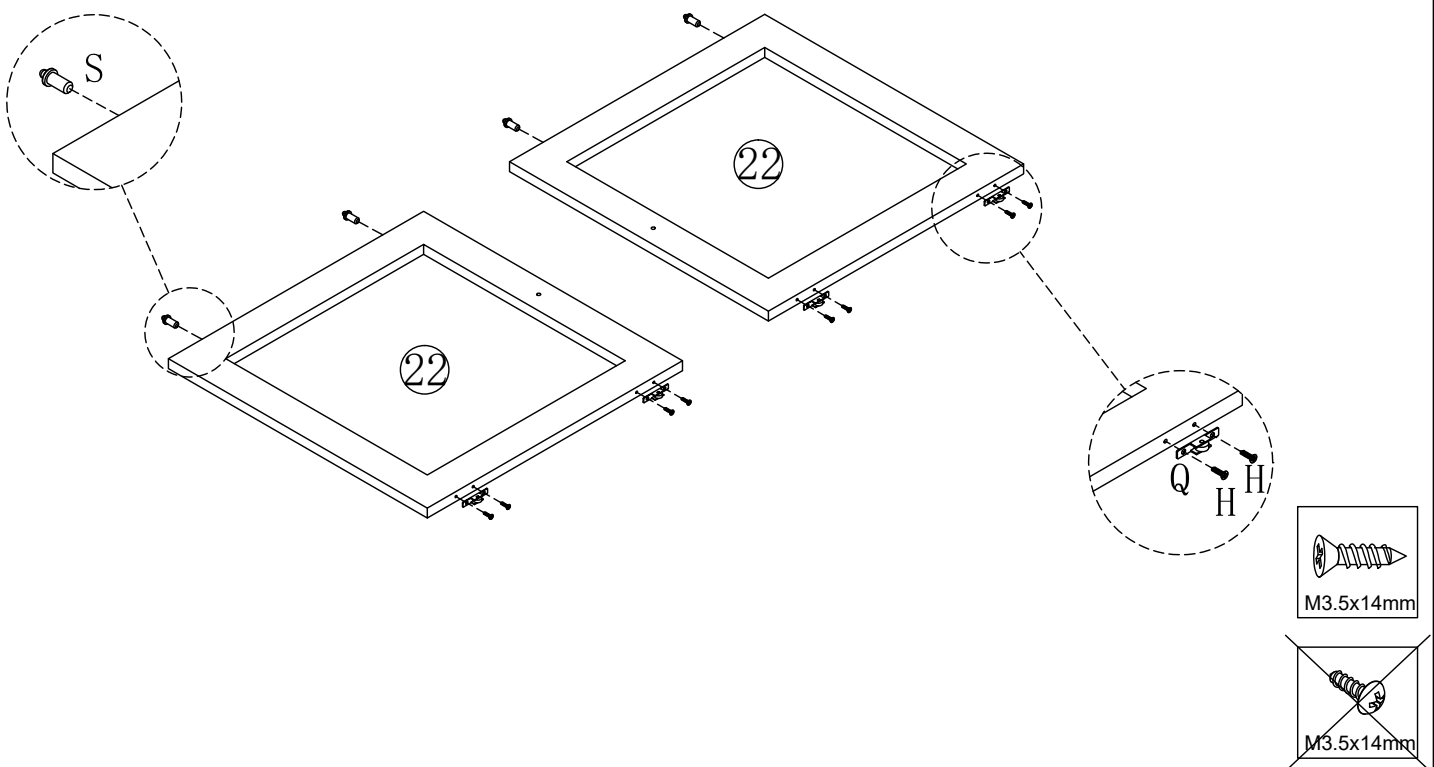

Step 32  
Schritt 32



M4x18mm

Ⓜ x2pcs



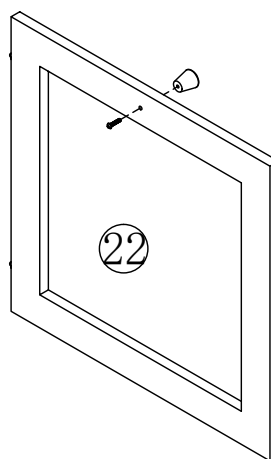
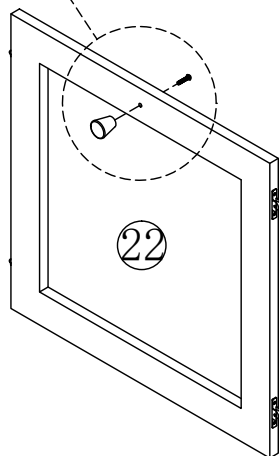
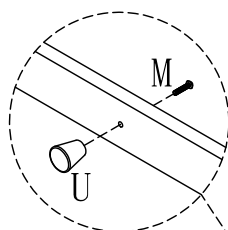

Ⓤ x2pcs



# Step 33

## Schritt 33

		
Ⓟx1pc	Ⓜx2pcs	Ⓜx12pcs

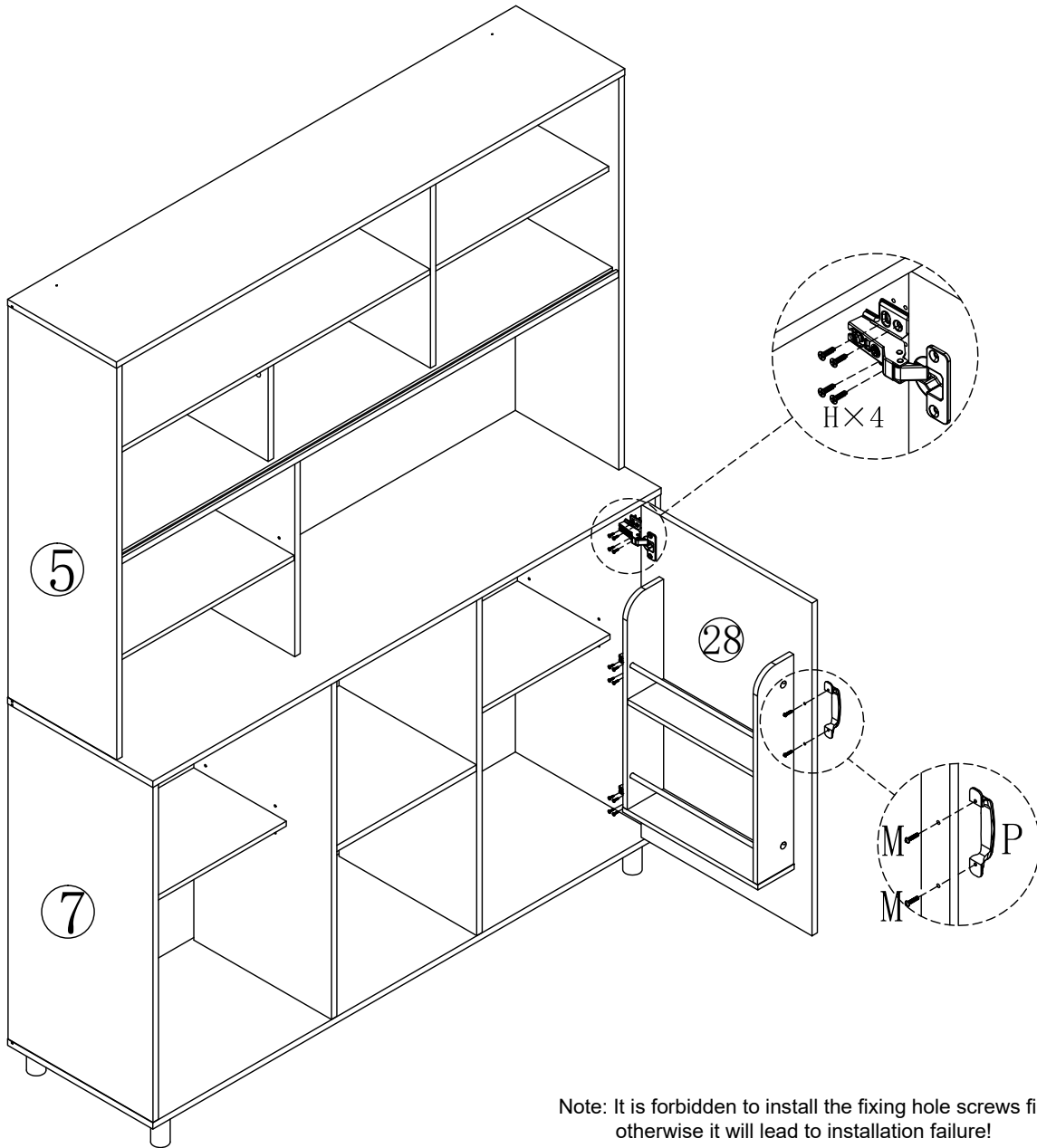

Note: It is forbidden to install the fixing hole screws first, otherwise it will lead to installation failure!

Remarque : Il est interdit d'installer d'abord les vis du trou de fixation, sinon cela entraînera un échec de l'installation !

Hinweis: Es ist verboten, zuerst die Befestigungslochschauben zu montieren, da dies sonst zu einem Installationsfehler führt!

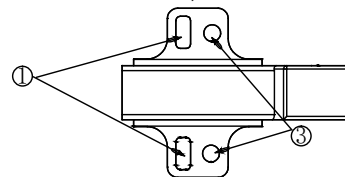

- ① Installez d'abord les vis du trou de réglage
- ② Mettez la porte dans la bonne position
- ③ Montieren Sie abschließend die Befestigungslochschauben

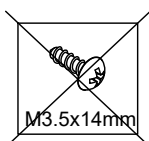
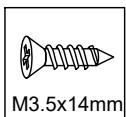

- ① Install the adjustment hole screws first
- ② Get the door in the right position
- ③ Finally, install the fixing hole screws

- ① Montieren Sie zuerst die Einstellochschauben
- ② Bringen Sie die Tür in die richtige Position
- ③ Enfin, installez les vis du trou de fixation



# Step 34

## Schritt 34

		
Ⓟx1pc	Ⓜx2pcs	Ⓜx12pcs

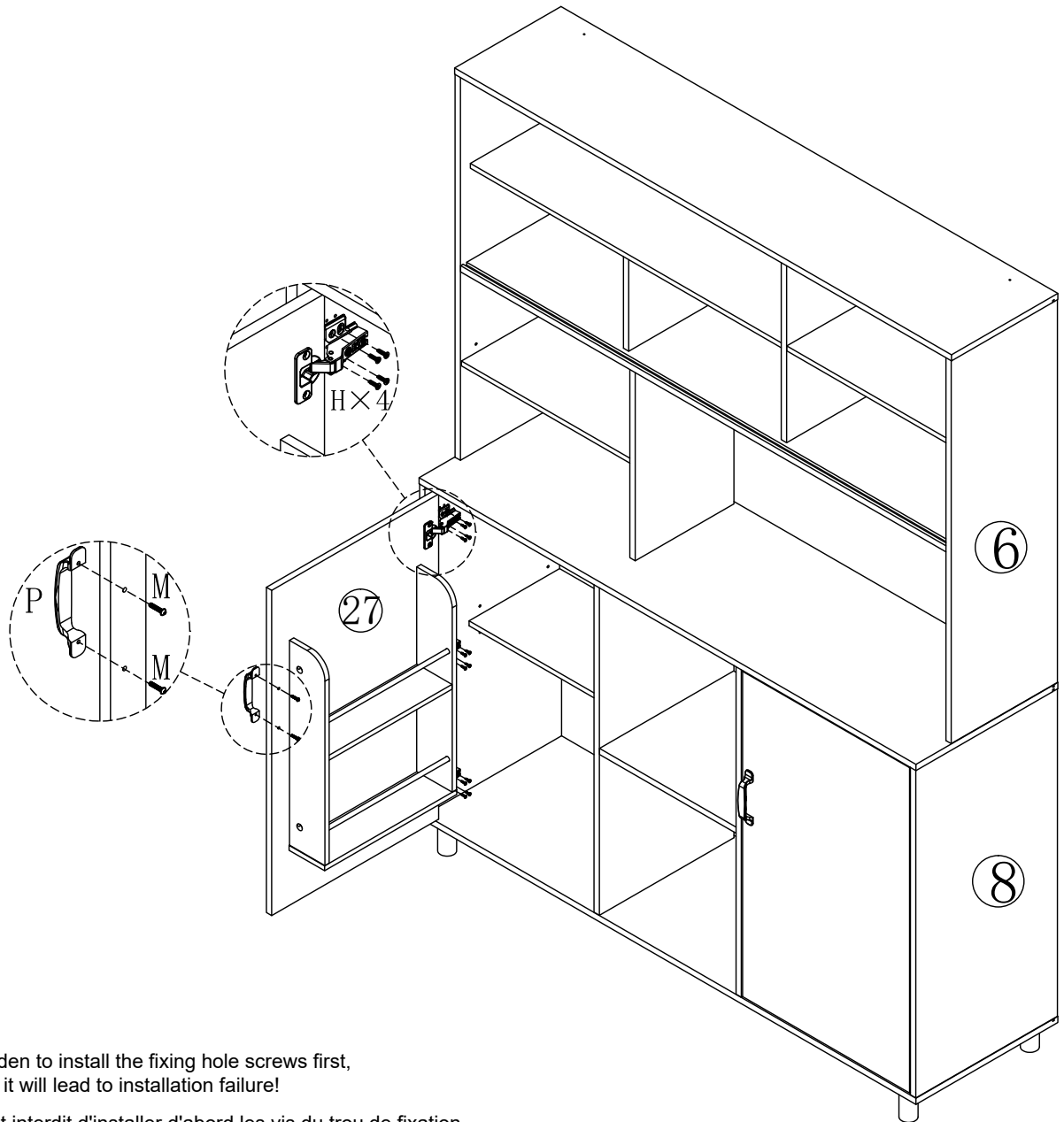

Note: It is forbidden to install the fixing hole screws first, otherwise it will lead to installation failure!

Remarque : Il est interdit d'installer d'abord les vis du trou de fixation, sinon cela entraînera un échec de l'installation !

Hinweis: Es ist verboten, zuerst die Befestigungslochschauben zu montieren, da dies sonst zu einem Installationsfehler führt!

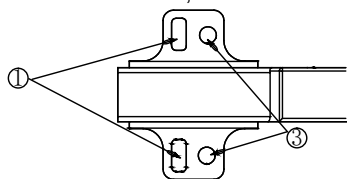

- ① Installez d'abord les vis du trou de réglage
- ② Mettez la porte dans la bonne position
- ③ Montieren Sie abschließend die Befestigungslochschauben

- ① Install the adjustment hole screws first
- ② Get the door in the right position
- ③ Finally, install the fixing hole screws

- ① Montieren Sie zuerst die Einstellochschauben
- ② Bringen Sie die Tür in die richtige Position
- ③ Enfin, installez les vis du trou de fixation

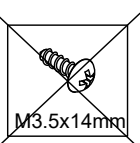
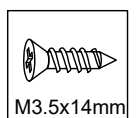

Step 35

Schritt 35

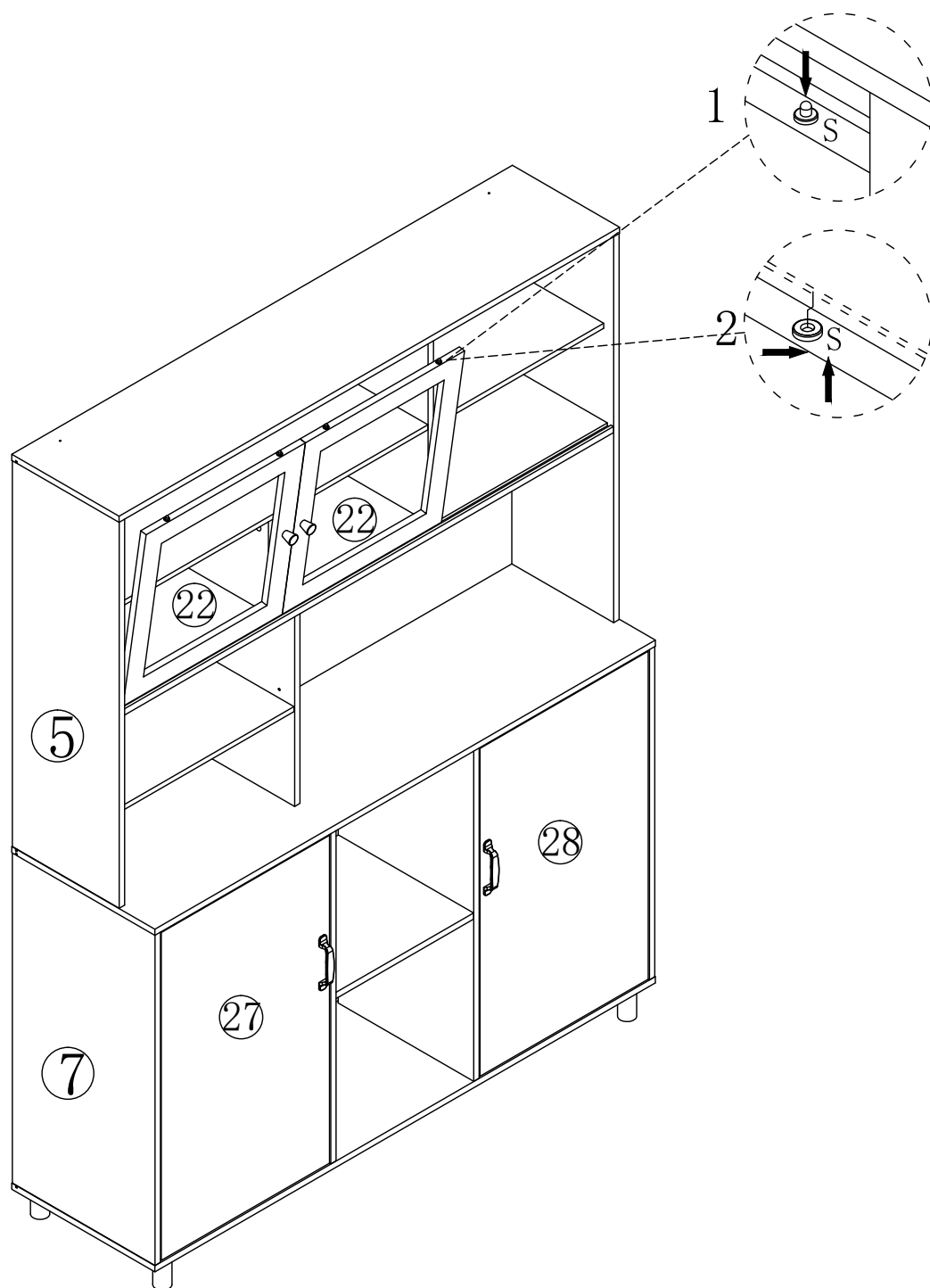

# Step 36

## Schritt 36

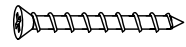

M4x40mm

Ⓓ x2pcs



Ⓙ x2pcs

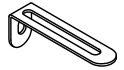

Ⓖ x2pcs

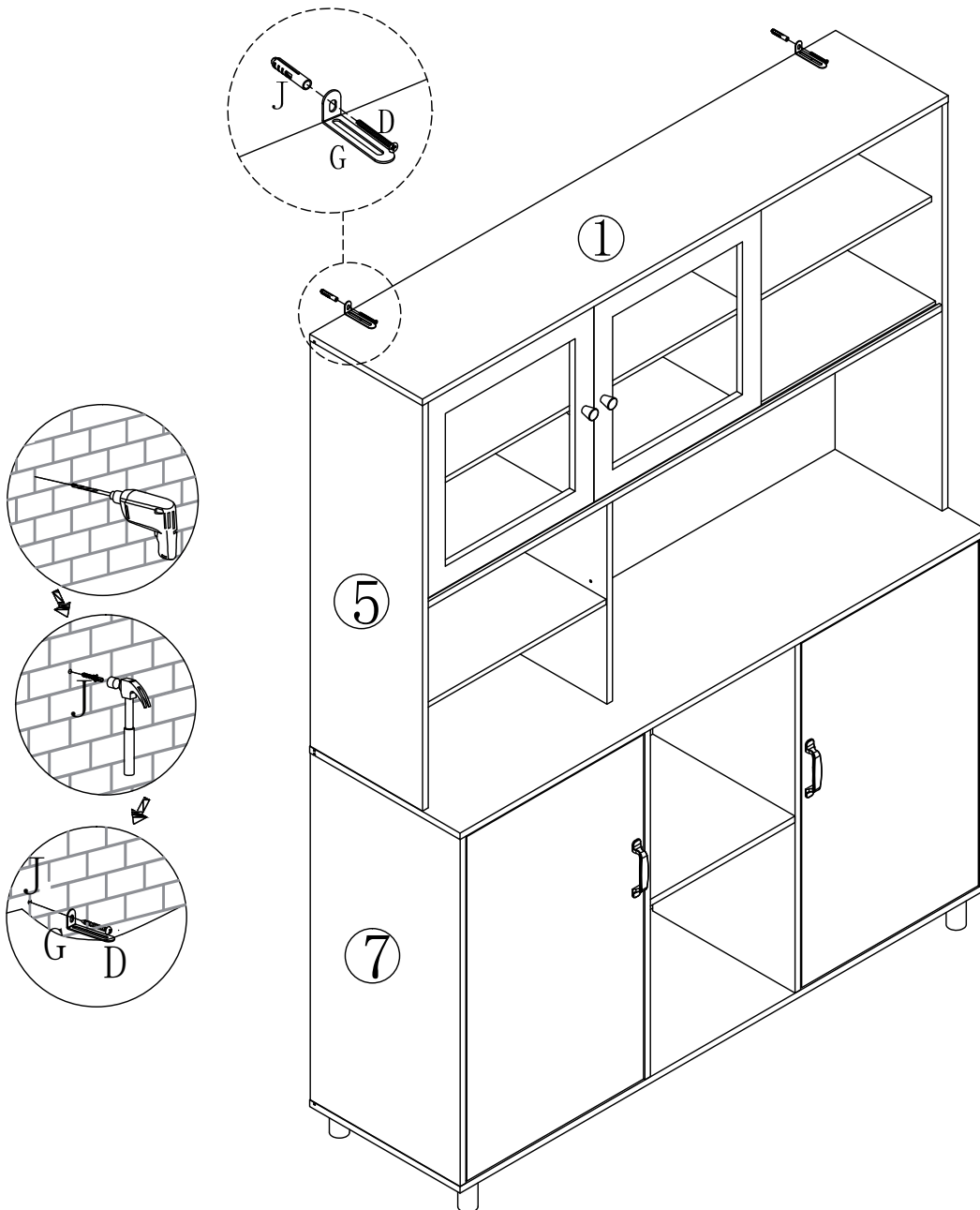

# Step 37

## Schritt 37



M3.5x14mm

ⓔx2pcs

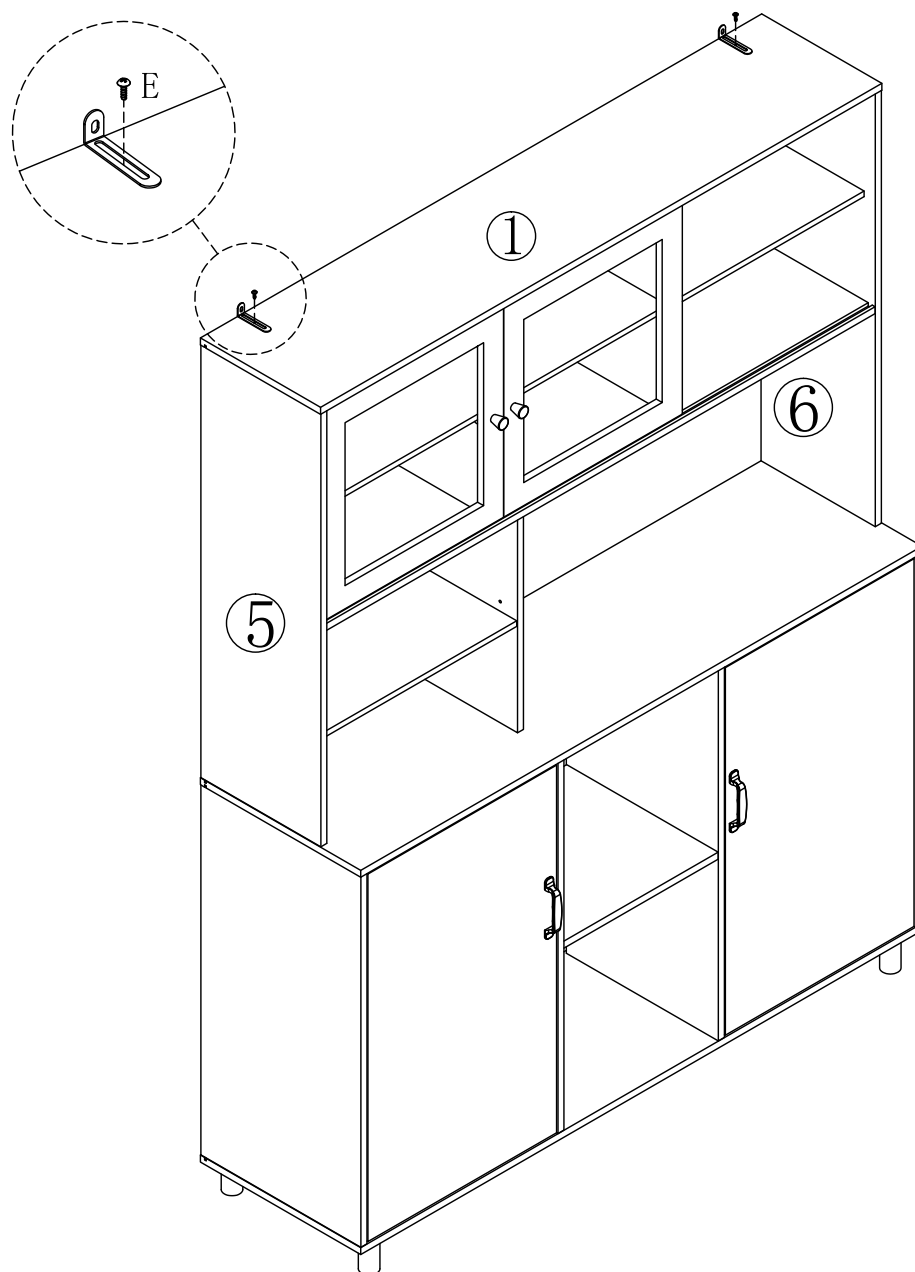

M3.5x14mm



M3.5x14mm

Shenzhen ZKT Technology Co., Ltd.  
 1/F, No. 101, Building B, No. 6, Tangwei Community Industrial Avenue,  
 Fuhai Street, Bao'an District, Shenzhen, China



# Certificate of Compliance

Certificate Number: ZKT-2403202774C

**Certificate's Holder :** Shenzhen Pinchengxin Technology Co., Ltd  
 3rd Floor, 8th Building Yuanling Industrial Zone, No. 39  
 Yuanlingcun Road, Shiyan Street, Bao'an District,  
 Shenzhen

**Manufacturer :** Shenzhen Pinchengxin Technology Co., Ltd  
 3rd Floor, 8th Building Yuanling Industrial Zone, No. 39  
 Yuanlingcun Road, Shiyan Street, Bao'an District,  
 Shenzhen

**Trade Mark :** N/A

**Product :** 5050 RGB LED Strip Lights with RF Controller and RF  
 Remote

**Model(s) :** 5050 RGB LED Strip Lights

**Test Standard :** Art.3.1(a) Safety EN IEC 62368-1:2020+A11:2020  
 Art.3.1(a) Health EN 62479: 2010  
 EN 50663:2017  
 Art.3.1(b) EMC ETSI EN 301 489-1 V2.2.3 (2019-11)  
 ETSI EN 301 489-3 V2.3.2 (2023-01)  
 Art.3.2 Radio ETSI EN 300 220-1 V3.1.1 (2017-02)  
 ETSI EN 300 220-2 V3.2.1 (2018-06)

This Attestation of Compliance is issued on a voluntary basis for electrical equipment below the  
 voltage limits of Radio Equipment Directive (RED) 2014/53/EU. The essential requirement are  
 fulfilled accordingly based on the technical specifications applicable at the time of issuance.



This Certificate of Conformity is based on single evaluation of the submitted sample(s) of the above mentioned  
 product. It does not imply an assessment of the whole product and relevant Directives to be observed.

+86-400 000 9970 +86-755-22336688 zkt@zkt-lab.com www.zkt-lab.com

Importeur	Decobus Handel GmbH		
Adresse	Innungsstraße 9,21244 Buchholz, Deutschland		
Email/URL	https://www.decobusgroup.de		
Hersteller	Shenzhen Pinchengxin Technology Co., Ltd		
Adresse	3rd Floor, 8th Building Yuanling Industrial Zone, No. 39Yuanlingcun Road, Shiyan Street, Bao'an District,Shenzhen		
Email/URL	Freja_zsj@163.com		
Hergestellt in	CHINA		
<table border="1"> <tr> <td>EC</td> <td>REP</td> </tr> </table>	EC	REP	Decobus Handel GmbH Innungsstraße 9,21244 Buchholz, Deutschland https://www.decobusgroup.de
EC	REP		



Produkt:LED-Lichtleiste  
 Modell:5050RGB  
 Nennspannung:5V  
 Nennfrequenz:50Hz/60Hz  
 Leistung:≤5W

**DE**

1. Die maximale Tragfähigkeit der Oberplatte beträgt 60 kg, bitte nicht überladen.
2. Lassen Sie Kinder nicht auf Möbeln klettern, da dies zu Umstürzen und schweren Verletzungen führen kann.
3. Um die Sicherheit zu gewährleisten, installieren Sie bitte gemäß der Anleitung und ziehen Sie bei Bedarf Fachleute hinzu.
4. Stellen Sie Möbel nicht in die Nähe von Feuerquellen oder heißen Gegenständen, um Brandgefahr zu vermeiden.
5. Stellen Sie Möbel nicht in feuchten Umgebungen auf, um Materialschäden zu verhindern.
6. Überprüfen Sie regelmäßig alle Verbindungs- und Befestigungselemente, um sicherzustellen, dass sie fest sitzen und Unfälle zu vermeiden.
7. Dieses Produkt ist mit einem Kipp-Schutz ausgestattet, installieren Sie diesen Schutz, um Verletzungen durch Umstürzen zu vermeiden.

**UK**

1. The maximum weight capacity of the top panel is 60kg; please do not overload.
2. Do not allow children to climb on furniture, as this may cause tipping and serious injury.
3. To ensure safety, please install correctly according to the instructions and seek professional assistance if necessary.
4. Do not place furniture near fire sources or hot objects to avoid fire hazards.
5. Do not place furniture in damp environments to prevent material damage.
6. Regularly check all connectors and fasteners to ensure they are secure to prevent accidents.
7. This product comes with a anti-tipping device; install this device to prevent injuries from tipping.

**FR**

1. La charge maximale du panneau supérieur est de 60 kg, ne pas surcharger.
2. Ne laissez pas les enfants grimper sur les meubles, cela peut entraîner des basculements et des blessures graves.
3. Pour garantir la sécurité, installez correctement selon les instructions et demandez l'aide de professionnels si nécessaire.
4. Ne placez pas les meubles près de sources de chaleur ou d'objets chauds pour éviter les risques d'incendie.
5. Ne placez pas les meubles dans des environnements humides pour éviter d'endommager les matériaux.
6. Vérifiez régulièrement tous les connecteurs et les fixations pour vous assurer qu'ils sont bien serrés et éviter les accidents.
7. Ce produit est équipé d'un dispositif anti-basculement; installez ce dispositif pour éviter les blessures dues au basculement.

**IT**

1. La capacità massima del pannello superiore è di 60 kg; non sovraccaricare.
2. Non permettere ai bambini di arrampicarsi sui mobili, poiché ciò può causare ribaltamenti e gravi infortuni.
3. Per garantire la sicurezza, installare correttamente secondo le istruzioni e, se necessario, chiedere assistenza a professionisti.
4. Non posizionare i mobili vicino a fonti di calore o oggetti caldi per evitare rischi di incendio.
5. Non posizionare i mobili in ambienti umidi per prevenire danni ai materiali.
6. Controllare regolarmente tutti i connettori e le viti per assicurarsi che siano saldi e prevenire incidenti.
7. Questo prodotto è dotato di un dispositivo anti-ribaltamento; installare questo dispositivo per evitare infortuni da ribaltamento.

**ES**

1. La capacidad máxima del panel superior es de 60 kg; no sobrecargar.
2. No permita que los niños escalen los muebles, ya que esto puede causar volcaduras y lesiones graves.
3. Para garantizar la seguridad, instale correctamente según las instrucciones y busque ayuda profesional si es necesario.
4. No coloque los muebles cerca de fuentes de fuego u objetos calientes para evitar riesgos de incendio.
5. No coloque los muebles en ambientes húmedos para evitar daños en los materiales.
6. Revise regularmente todos los conectores y sujetadores para asegurarse de que estén seguros y prevenir accidentes.
7. Este producto viene con un dispositivo anti-vuelco; instale este dispositivo para prevenir lesiones por vuelcos.

**NL**

1. De maximale draagcapaciteit van het bovenpaneel is 60 kg; niet overbelasten.
2. Laat kinderen niet op meubels klimmen, dit kan leiden tot omvallen en ernstige verwondingen.
3. Installeer correct volgens de instructies om de veiligheid te waarborgen, en schakel indien nodig professionele hulp in.
4. Plaats meubels niet in de buurt van vuurbronnen of warme objecten om brandgevaar te voorkomen.
5. Plaats meubels niet in vochtige omgevingen om materiaalschade te voorkomen.
6. Controleer regelmatig alle verbindingen en bevestigingsmiddelen om ervoor te zorgen dat ze stevig zijn en om ongevallen te voorkomen.
7. Dit product is uitgerust met een kantelbeveiliging; installeer dit apparaat om verwondingen door omvallen te voorkomen.

**SE**

1. Den maximala viktkapaciteten för överpanelen är 60 kg; överbelasta inte.
2. Låt inte barn klättra på möbler, då detta kan orsaka tippning och allvarliga skador.
3. För att säkerställa säkerheten, installera korrekt enligt instruktionerna och sök professionell hjälp om det behövs.
4. Placera inte möbler nära eldkällor eller heta föremål för att undvika brandrisk.
5. Placera inte möbler i fuktiga miljöer för att förhindra skador på materialen.
6. Kontrollera regelbundet alla kopplingar och fästelement för att säkerställa att de är säkra för att förhindra olyckor.
7. Denna produkt levereras med en anti-tippanordning; installera denna anordning för att förhindra skador vid tippning.

**PL**

1. Maksymalne obciążenie górnej płyty wynosi 60 kg; nie przeciążaj.
2. Nie pozwól dzieciom wspinać się na meble, ponieważ może to prowadzić do przewrócenia się i poważnych obrażeń.
3. Aby zapewnić bezpieczeństwo, zainstaluj prawidłowo zgodnie z instrukcją i w razie potrzeby skorzystaj z pomocy profesjonalistów.
4. Nie stawiaj mebli w pobliżu źródeł ognia lub gorących przedmiotów, aby uniknąć ryzyka pożaru.
5. Nie stawiaj mebli w wilgotnych środowiskach, aby zapobiec uszkodzeniu materiałów.
6. Regularnie sprawdzaj wszystkie złącza i elementy mocujące, aby upewnić się, że są stabilne i aby zapobiec wypadkom.
7. Produkt ten jest wyposażony w urządzenie zapobiegające przewróceniu; zainstaluj to urządzenie, aby uniknąć obrażeń w wyniku przewrócenia.