

[EN] Product manual

[DE] Benutzerhandbuch

[FR] Manuel de l'utilisateur

[ES] Manual de instrucciones

[IT] Manuale d'uso

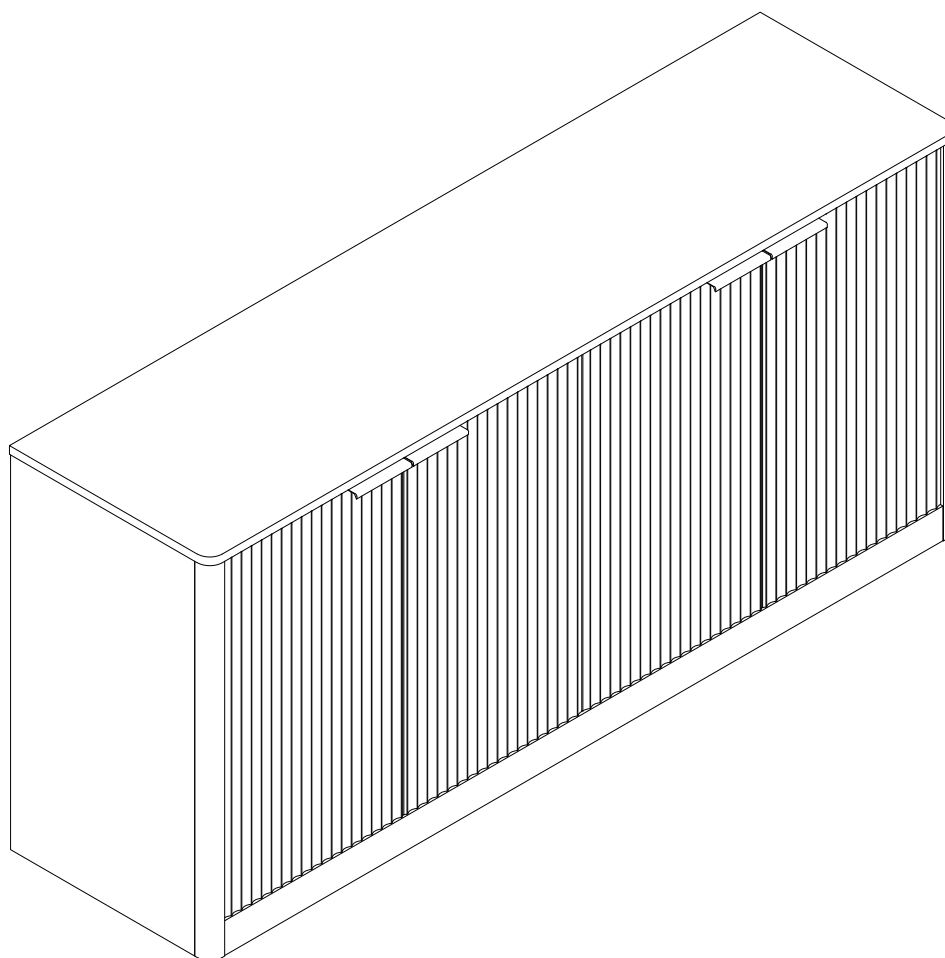

OZ-CBN166

Allgemeine Leitlinien

- Bitte lesen Sie die folgenden Anweisungen sorgfältig durch und verwenden Sie das Produkt entsprechend
- Bitte bewahren Sie dieses Handbuch auf und geben Sie es bei der Weitergabe des Produkts weiter.
- Diese Zusammenfassung kann nicht alle Varianten und die in Betracht gezogenen Schritte in allen Einzelheiten aufzeigen. Bitte kontaktieren Sie uns, wenn Sie weitere Informationen und Hilfe benötigen.

Notizen

- Dieses Produkt ist nur für den ausschließlichen Gebrauch. Das Produkt muß nach der Beschreibung zusammengebaut und verwendet werden. Eine Schädigung der Person und/oder eine Beschädigung des Produkts können eintreten, wenn das Produkt nicht zum erwarteten Zweck genutzt und/oder vom ursprünglichen Design verändert/verändert wird.
- Der Verkäufer übernimmt keine Verantwortung oder Haftung für Verletzungen/Schäden, die durch unsachgemäßen Zusammenbau oder unsachgemäßen Gebrauch verursacht werden.
- Hinterlassen Sie keine heißen Objekte auf der Oberfläche.
- Wenn die Verpackung entfernt wird und Mängel festgestellt werden, hören Sie bitte sofort auf, zusammenzubauen und uns zu kontaktieren.
- Bauen Sie die Produkte bitte auf einer geräuber Oberfläche zusammen. Vermeiden Sie, dass ausgeschnittene Produkte unbeschädigt auf den Boden gelegt werden.
- Trage beim Zusammenziehen und/oder Zerlegen Handschuhe, um einen scharfen Rand zu vermeiden.
- Bitte die Seriennummer der Komponenten in der Anleitung anpassen.
- Wenn ein Ersatzteil nicht passt, überprüfen Sie die in diesem Handbuch beschriebenen Regeln.
- Bei einem speziellen Bau werden zunächst alle Schrauben angebracht, damit die Schrauben gespannt sind.
- Die Verwendung des Geräts wird regelmäßig nach Schraube kontrolliert. Gegebenenfalls strafft, um die strukturelle Integrität zu gewährleisten.
- Vermeiden Sie scharfe Objekte und ätzende Stoffe.
- Verwenden Sie das Gerät immer auf ebenem und festem Boden.

Warnung

- Bei der Montage jedes einzelne Element so einsetzen, dass es für Kinder unerreichbar ist. Wenn Sie einsteigen, könnte Sie tödlich sein.
- Vermeiden Sie Säuglinge und Kinder mit allen Bestandteilen (Film, Plastiktüten, Schaum usw.) und der Verpackung (Film -, Plastik -, Kunststoffolie usw.).
- Artikel mit spitzen Gegenständen und ätzenden Eigenschaften, die vermeiden, dass Sie beschädigt oder beschädigt werden.

General Guidelines

- Please read the following instructions carefully and use the product accordingly
- Please keep this manual and hand it over when you transfer the product.
- This summary may not include every detail of all variations and considered steps. Please contact us when further information and help are needed.

Notes

- The product is intended for indoor use only. The product must be assembled and used in accordance with the provisions of the manual. Personal injury and/or damage to product may occur if it is used outside of its intended purposes and/or if it has been changed/modified from its original design.
- The seller does not assume any responsibility or liability for any injury/damage caused by incorrect assembly or improper use.
- Keep the product away from fire sources and high temperatures.
- Do not place any hot objects on the surface of the product.
- If there are any defective or missing parts after unpacking, please cease assembly immediately and contact us.
- Please assemble the item on a spacious surface and do not place the unwrapped product directly on the ground to avoid product damage.
- Please wear gloves during the assembly and/or disassembly process to avoid scratches from any sharp edges.
- Please match the corresponding part and fitting based on the part number in the manual.
- If the part does not match with the fitting, please check the piece as specified in this manual.
- During assembly, first loosely align all screws with the corresponding pre-drilled holes and then tighten the screws one by one.
- Periodically inspect screw tightness while the product is in use. If necessary, retighten to ensure structural integrity.
- Please keep the product away from sharp, pointed objects and corrosive substances to prevent product damage.
- Please place this item on level, solid ground during use.

Warnings

- During assembly, keep all small parts out of the reach of children. It may be fatal if swallowed or inhaled.
- To avoid the potential dangers of suffocation, please keep all parts and packaging (film, plastic bags, foam, etc.) away from babies and children.
- Keep sharp objects and corrosive items away from the product to avoid any damage or injury.

Lignes directrices générales

- Lisez attentivement les instructions suivantes et utilisez le produit en conséquence.
- Gardez le manuel prêt pour le transfert.
- Le résumé peut ne pas inclure toutes les modifications ou les phases à l'étude. Pour de plus amples informations et de l'aide, veuillez contacter:

Notes

- Le produit est réservé à un usage personnel. Les produits doivent être assemblés et utilisés conformément au mode d'emploi. Des dommages corporels et/ou des dommages au produit peuvent survenir si le produit n'a pas été utilisé aux fins prévues et/ou a été modifié/modifié par la conception originale.
- Le vendeur n'est pas responsable des blessures ou des dommages causés par un montage incorrect ou une mauvaise utilisation.
- Tenir à l'écart du feu et de la chaleur.
- Orienter pour éviter de laisser des objets chauds à la surface.
- Si l'emballage est enlevé et qu'il y a des défauts ou des défauts, arrêtez immédiatement l'assemblage et contactez-nous.
- Opt veuillez assembler le produit sur une surface propre. Évitez de mettre les produits non coupés sur le sol intacts.
- Peler et/ou enlever les gants pour éviter les arêtes tranchantes.
- Changez le numéro de série de la pièce dans le manuel.
- Vérifiez les règles décrites dans ce manuel si les pièces remplacées ne conviennent pas.
- Vissez les vis pour les visser.
- Vissez régulièrement pour vérifier l'utilisation de l'appareil. Le cas échéant, l'armature est nécessaire pour assurer l'intégrité structurale.
- Renforcer pour éviter les objets pointus et les substances corrosives.
- L'essai doit être effectué sur une surface plane et dure.

Avertissement

- Pendant le montage, gardez toutes les petites pièces hors de portée des enfants. elles peuvent être mortelles si elles sont avalées ou inhalées. Afin d'éviter les risques potentiels de suffocation, veuillez tenir toutes les pièces et l'emballage (film, sacs en plastique, mousse, etc.) hors de portée des bébés et des enfants.
- Tenir les objets tranchants et corrosifs à l'écart du produit afin d'éviter tout dommage ou blessure.

Linee guida generali

- Leggere attentamente le istruzioni che seguono e utilizzare il prodotto di conseguenza.
- Tenere il manuale pronto per il trasferimento.
- Questa sintesi potrebbe non includere tutti i dettagli di tutti i cambiamenti e le fasi da considerare. Per ulteriori informazioni e assistenza, contattateci.

Appunti

- Il prodotto è destinato esclusivamente ad uso personale. I prodotti devono essere assemblati e utilizzati conformemente alle istruzioni per l'uso. Possono verificarsi danni alle persone e/o danni al prodotto se il prodotto non è stato utilizzato per lo scopo previsto e/o se è stato modificato/modificato dal progettista originale.
- Il venditore non è responsabile di eventuali lesioni o danni causati da un montaggio errato o da un uso improprio.
- Tenere lontano dal fuoco e dal calore.
- Sterzare per non lasciare oggetti caldi sulla superficie.
- Se l'imballaggio viene smontato e si riscontrano difetti o difetti, interrompere immediatamente il montaggio e mettersi in contatto con noi.
- Per favore assemblare il prodotto su una superficie pulita. Evitare di mettere i prodotti non tagliati sul pavimento intatti.
- Sterzare e/o togliere guanti per evitare che i bordi siano affilati.
- Cambiare il numero di serie del pezzo nel manuale.
- Verificare le regole descritte in questo manuale se le parti sostituite non sono adatte.
- Avvitare le viti per avvitare.
- Avvitare regolarmente per verificare l'uso dell'apparecchio. Se necessario, il rafforzamento è necessario per garantire l'integrità strutturale.
- Sterzare per evitare oggetti appuntiti e sostanze corrosive.
- La prova deve essere effettuata su una superficie piana e dura.

Avvertimento

- Utilizzare ogni singolo elemento nel processo di assemblaggio, in modo che i bambini non possano accedervi. Potrebbe essere fatale se entrassero.
- Evitare che i bambini e i bambini entrino in contatto con tutti i materiali (pellicola, borsa di plastica, schiuma, ecc.) e con gli imballaggi (pellicola, plastica, pellicola di plastica, ecc.).
- Oggetti appuntiti e corrosivi da evitare di essere danneggiati o danneggiati.

Criterios generales

- Lea las siguientes instrucciones cuidadosamente y utilice el producto en consecuencia.
- Tener el manual listo para la transferencia.
- Es posible que este resumen no incluya todos los detalles de todos los cambios y pasos a tener en cuenta. Para más información y ayuda, póngase en contacto con nosotros.

Instrucciones

- Este producto es solo para uso personal. El producto debe ser montado y utilizado de acuerdo con las instrucciones. Lesiones personales y/o daños al producto pueden ocurrir si el producto no se utiliza para el propósito previsto y/o ha sido modificado/modificado por el diseño original.
- El vendedor no se hace responsable de las lesiones o daños causados por un montaje incorrecto o un uso inadecuado.
- Mantener alejado del fuego y el calor.
- Posicionamiento para evitar dejar objetos calientes en la superficie.
- Si el paquete se retira y es defectuoso o defectuoso, detenga el montaje de inmediato y póngase en contacto con nosotros.
- Opción de ensamblar el producto en una superficie limpia. Evite dejar productos sin cortar en el suelo intactos.
- Pelar y/o quitarse los guantes para evitar los bordes afilados.
- Cambiar el número de serie de la pieza en el manual.
- Si la pieza de repuesto no es adecuada, revise las reglas descritas en este manual.
- Fijación de tornillos con tornillos.
- Compruebe regularmente el uso del equipo. Cuando proceda, se requiere un marco para garantizar la integridad estructural.
- Reforzado para evitar objetos puntiagudos y sustancias corrosivas.
- La prueba debe realizarse en una superficie dura y plana.

Advertencia

- Utilice cada elemento individual durante el montaje para que los niños no puedan acceder a ellos. Si entran, pueden ser mortales.
- Evitar el contacto de bebés y bebés con todos los materiales (cortex, bolsas de plástico, caucho, etc.) y materiales de embalaje (cortex, plástico, plástico, etc.).
- piezas punzantes y corrosivas para evitar ser dañadas o dañadas.

Parts List (EN)

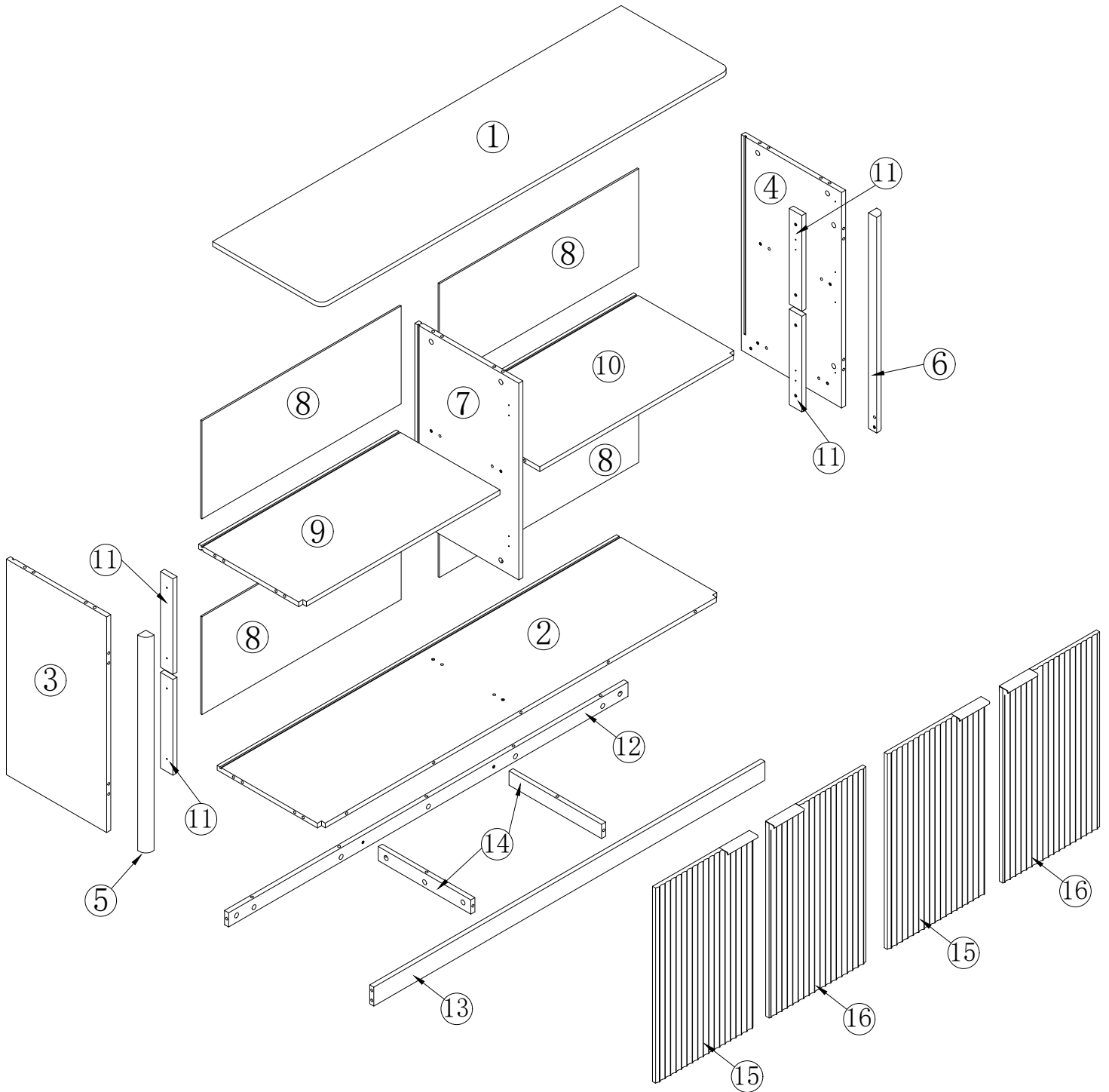

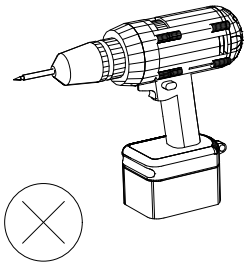
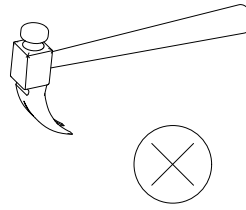
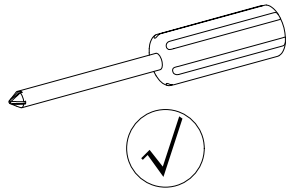
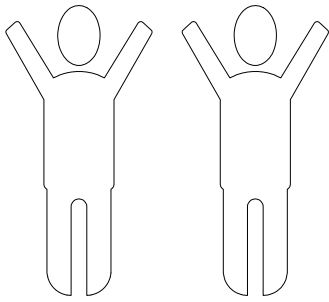

Parts List (EN)

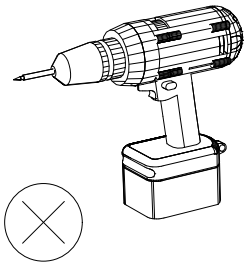
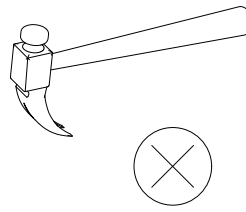
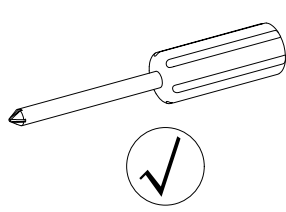
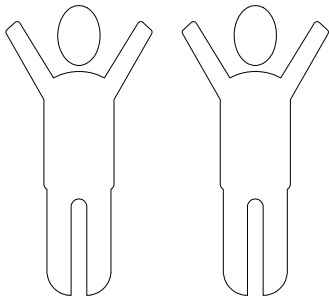

<p>①</p> <p>1PCS</p>	<p>②</p> <p>1PCS</p>	<p>③</p> <p>1PCS</p>	<p>④</p> <p>1PCS</p>
<p>⑤</p> <p>1PCS</p>	<p>⑥</p> <p>1PCS</p>	<p>⑦</p> <p>1PCS</p>	<p>⑧</p> <p>4PCS</p>
<p>⑨</p> <p>1PCS</p>	<p>⑩</p> <p>1PCS</p>	<p>⑪</p> <p>4PCS</p>	<p>⑫</p> <p>1PCS</p>
<p>⑬</p> <p>1PCS</p>	<p>⑭</p> <p>2PCS</p>	<p>⑮</p> <p>2PCS</p>	<p>⑯</p> <p>2PCS</p>

Parts List (EN)

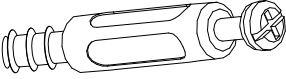

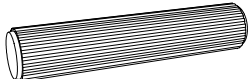
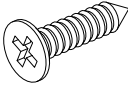
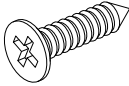
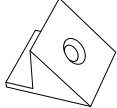
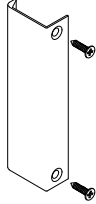
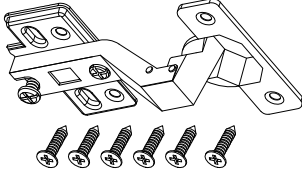
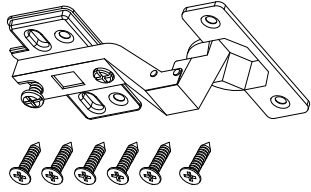
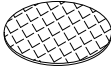
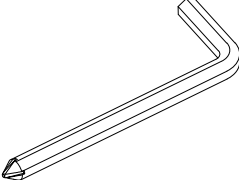

<p>A</p>  <p>∅6*35mm</p> <p>44+2PCS</p>	<p>B</p>  <p>∅15*9.5mm</p> <p>44+2PCS</p>	<p>C</p>  <p>∅8*30mm</p> <p>26+2PCS</p>
<p>D</p>  <p>∅3.5*14mm</p> <p>16+2PCS</p>	<p>E</p>  <p>∅3.5*25mm</p> <p>8+2PCS</p>	<p>F</p>  <p>16+2PCS</p>
<p>G</p>  <p>[EN]Handle [FR]Poignée [DE]Griff</p> <p>4sets</p>	<p>H</p>  <p>[EN]Mid bend door hinge. [FR]Charnière de porte à courbure moyenne. [DE]Türscharnier mit mittlerer Biegung.</p> <p>4sets</p>	<p>I</p>  <p>[EN]Large curved door hinge [FR]Grande charnière de porte incurvée [DE]Großes gebogenes Türscharnier</p> <p>4sets</p>
<p>J</p>  <p>20+2 PCS</p>	<p>K</p>  <p>M4</p> <p>1PCS</p>	

Assembly Steps (EN)

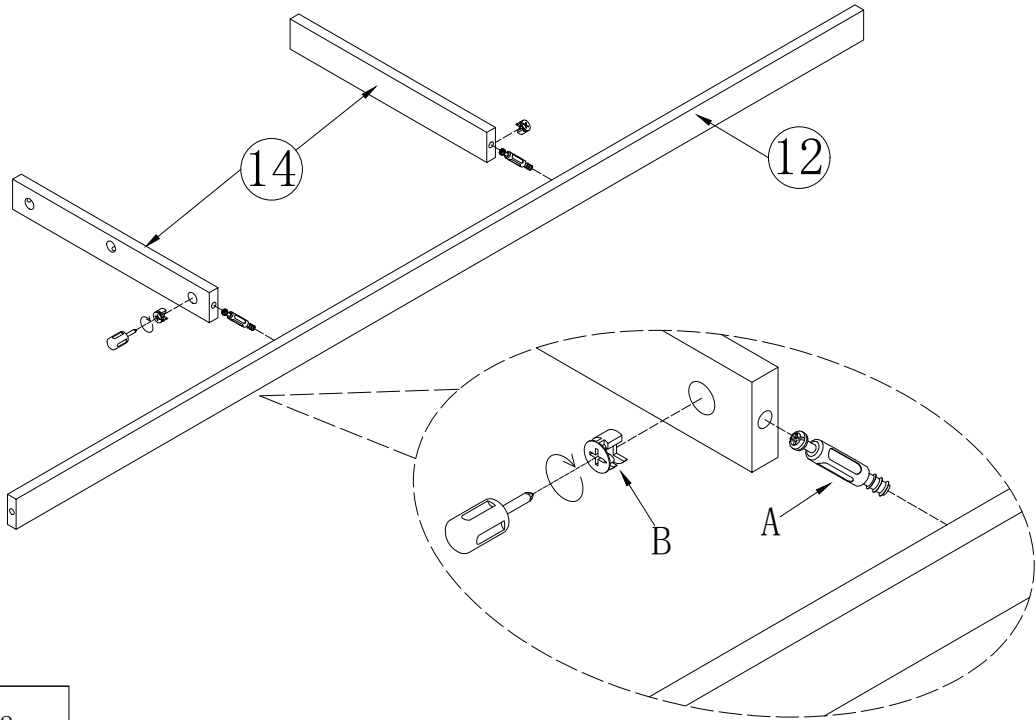

Step 1

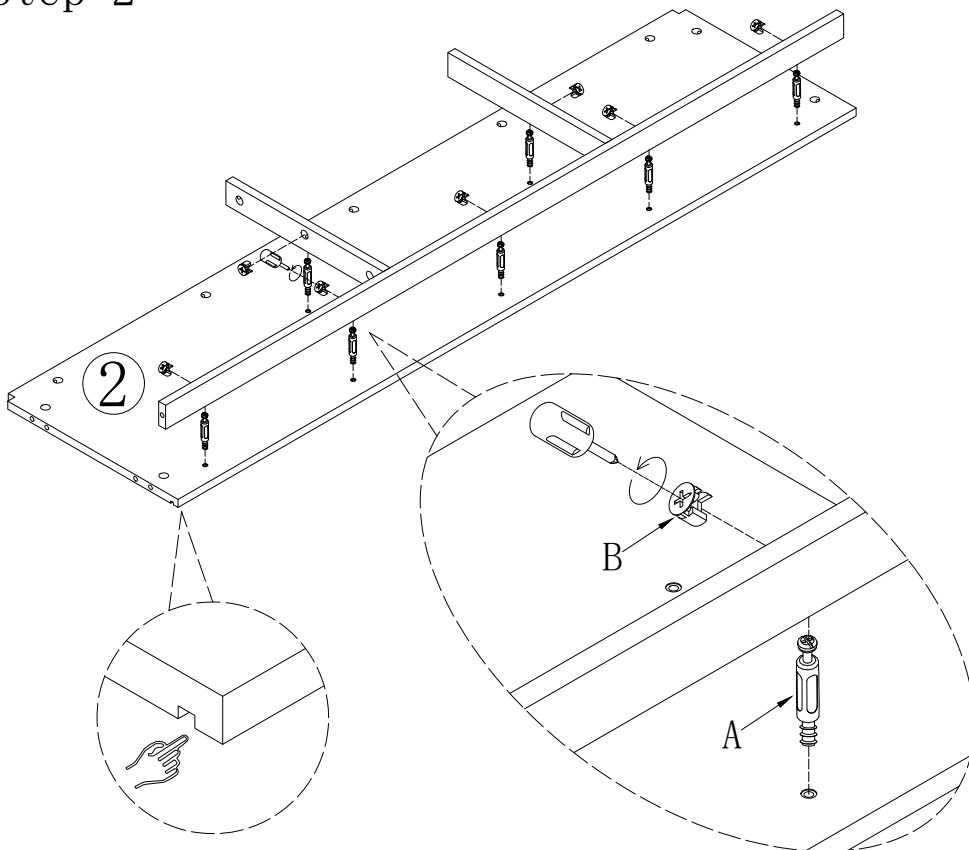

	Ax2pcs
	Bx2pcs

Step 2





	Ax7pcs
	Bx7pcs

Assembly Steps (EN)

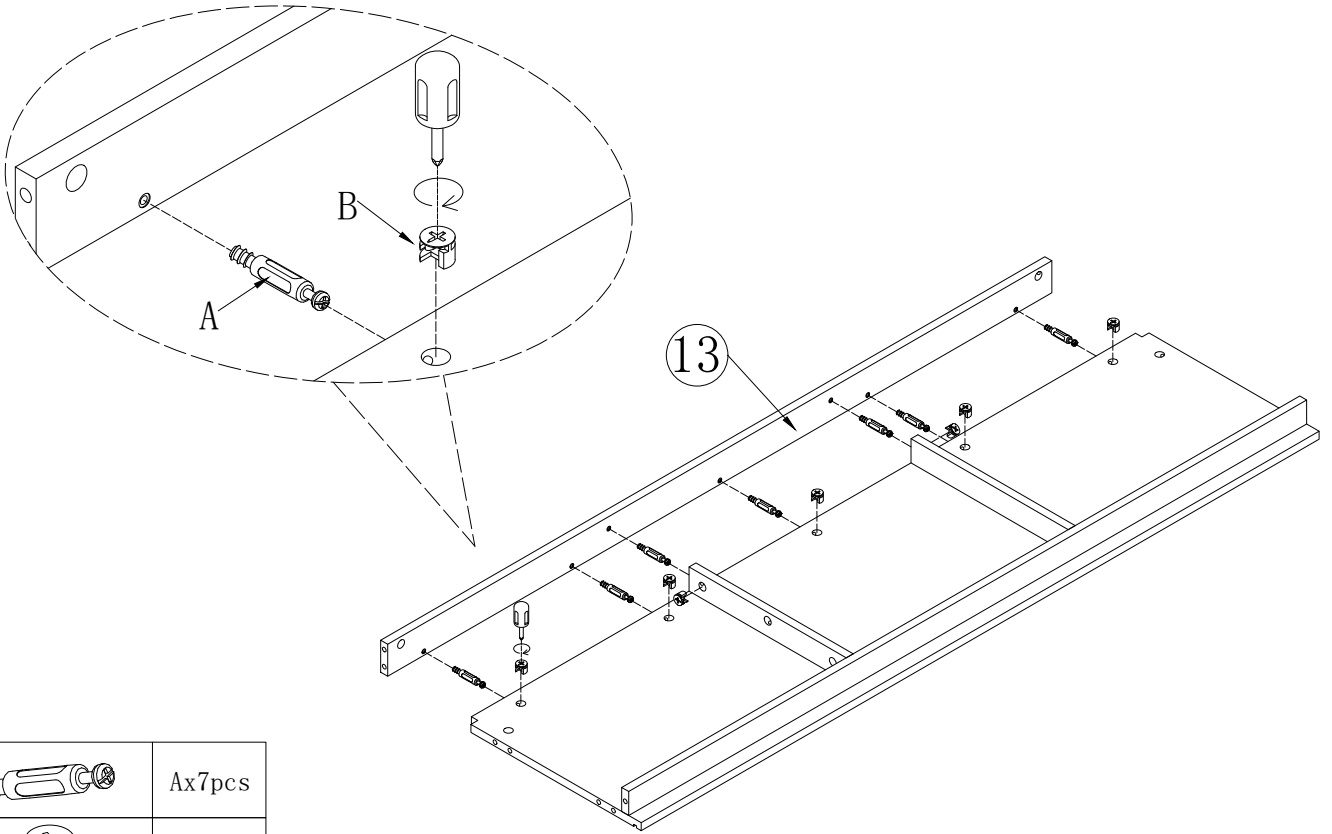

Step 3

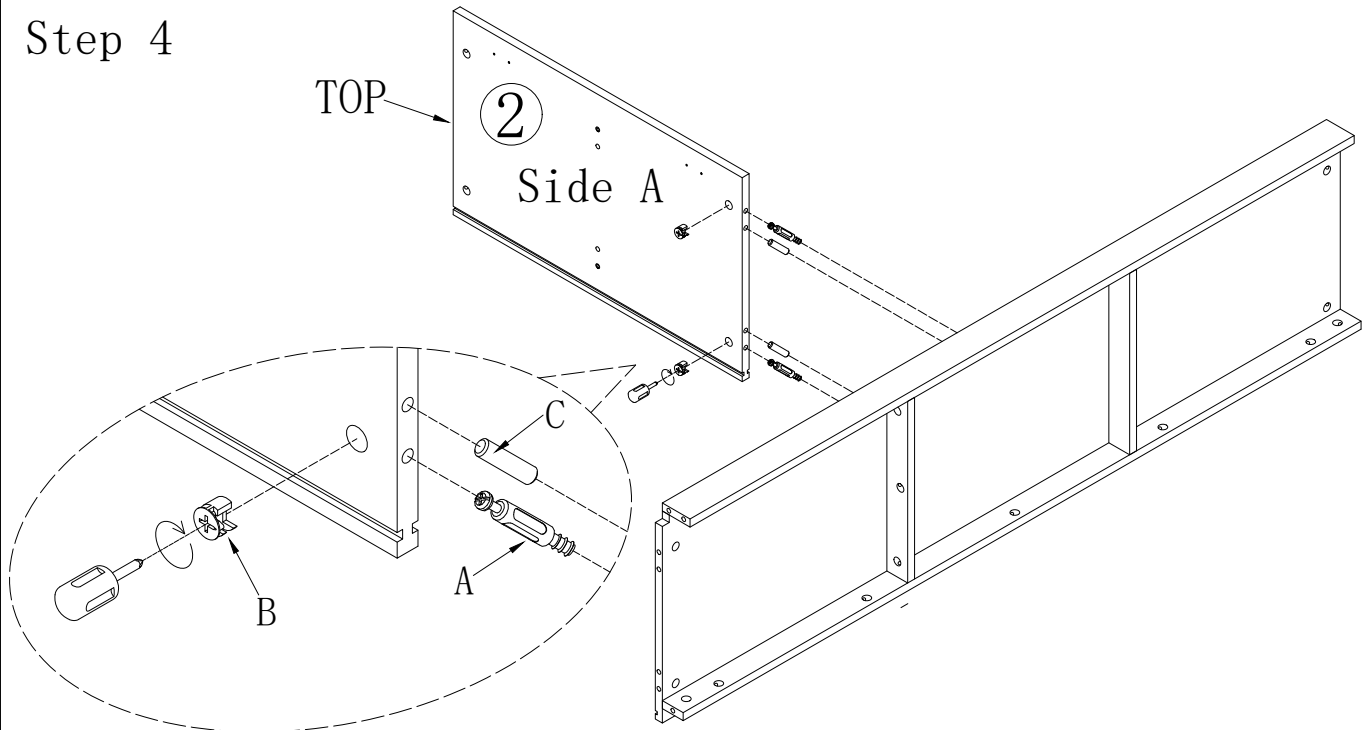

	Ax7pcs
	Bx7pcs

Step 4





	Ax2pcs
	Bx2pcs
	Cx2pcs

Assembly Steps (EN)

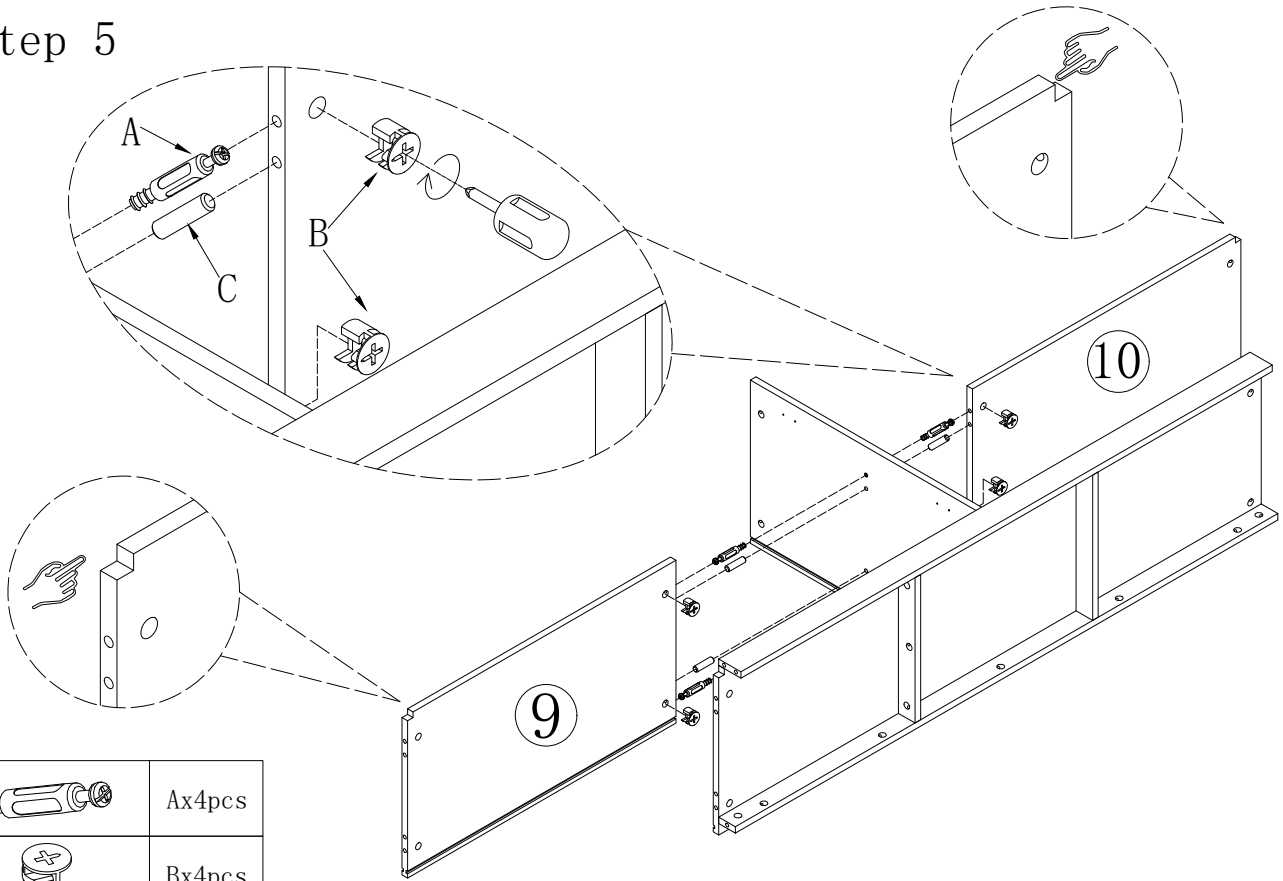
Step 5

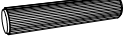

	Ax4pcs
	Bx4pcs
	Cx4pcs

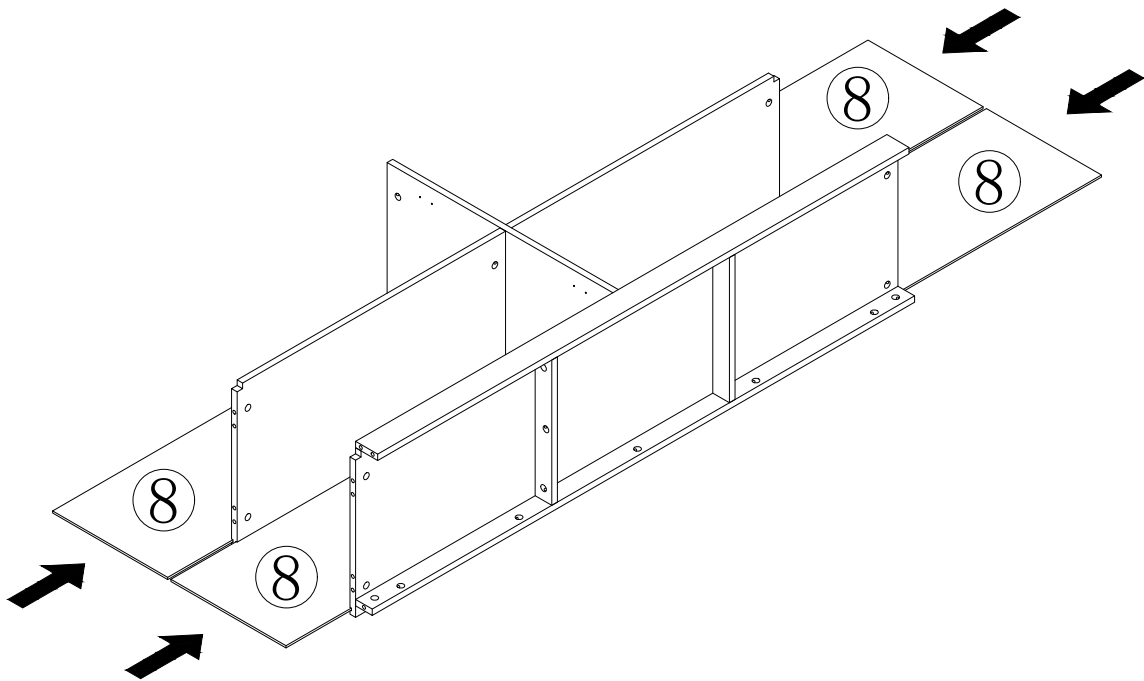

Step 6



Assembly Steps (EN)

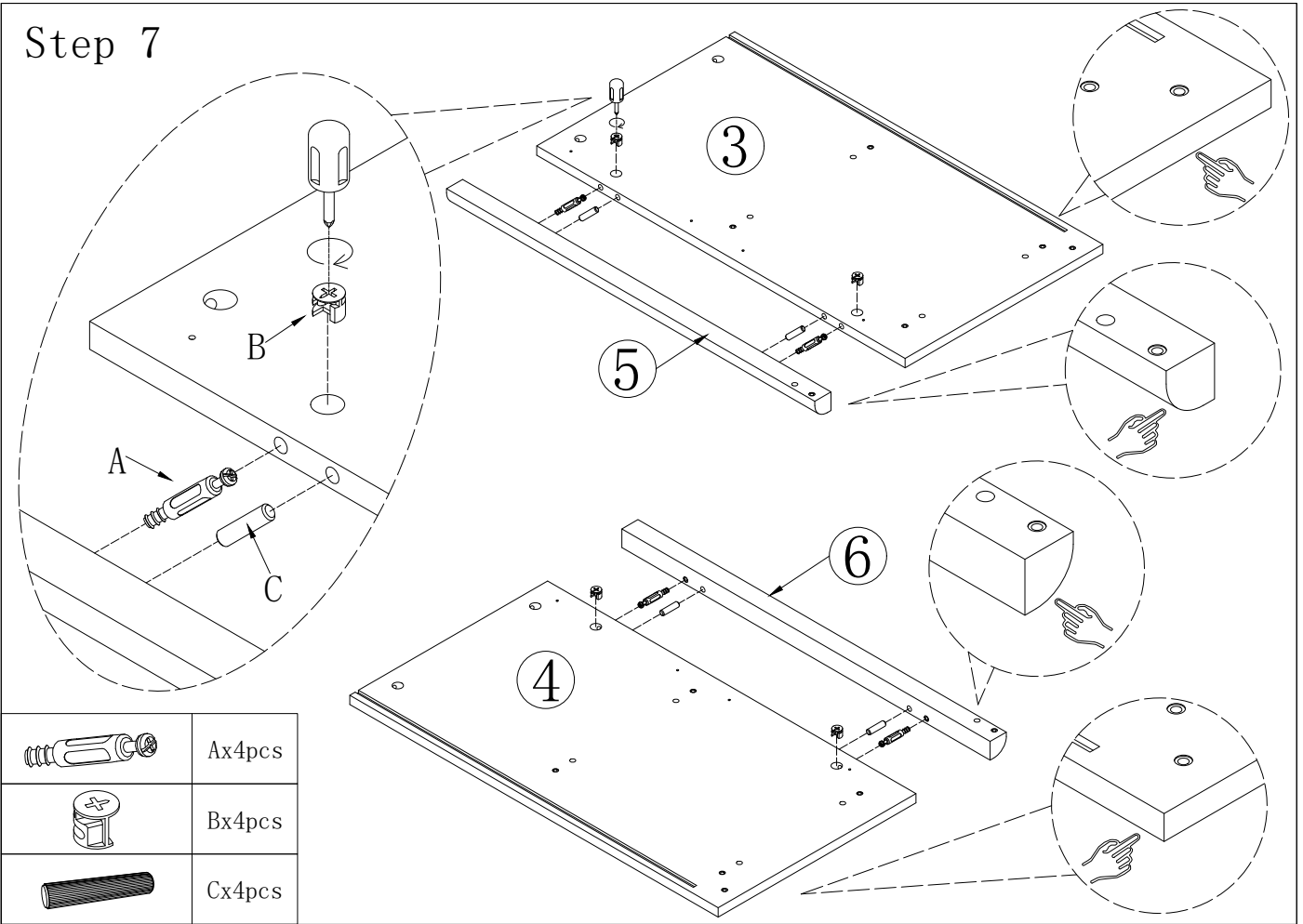

Step 7

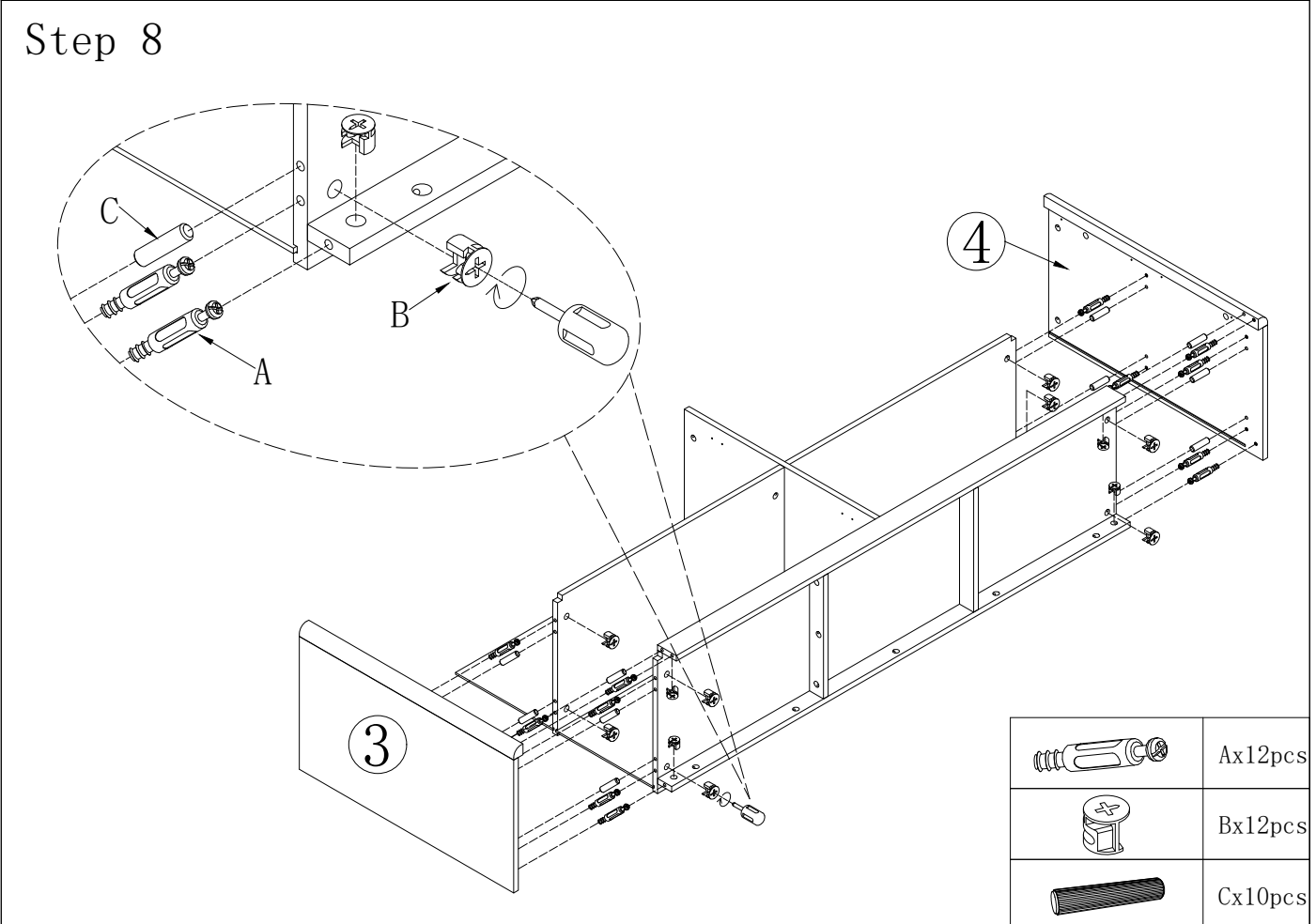

	Ax4pcs
	Bx4pcs
	Cx4pcs

Step 8





	Ax12pcs
	Bx12pcs
	Cx10pcs

Assembly Steps (EN)

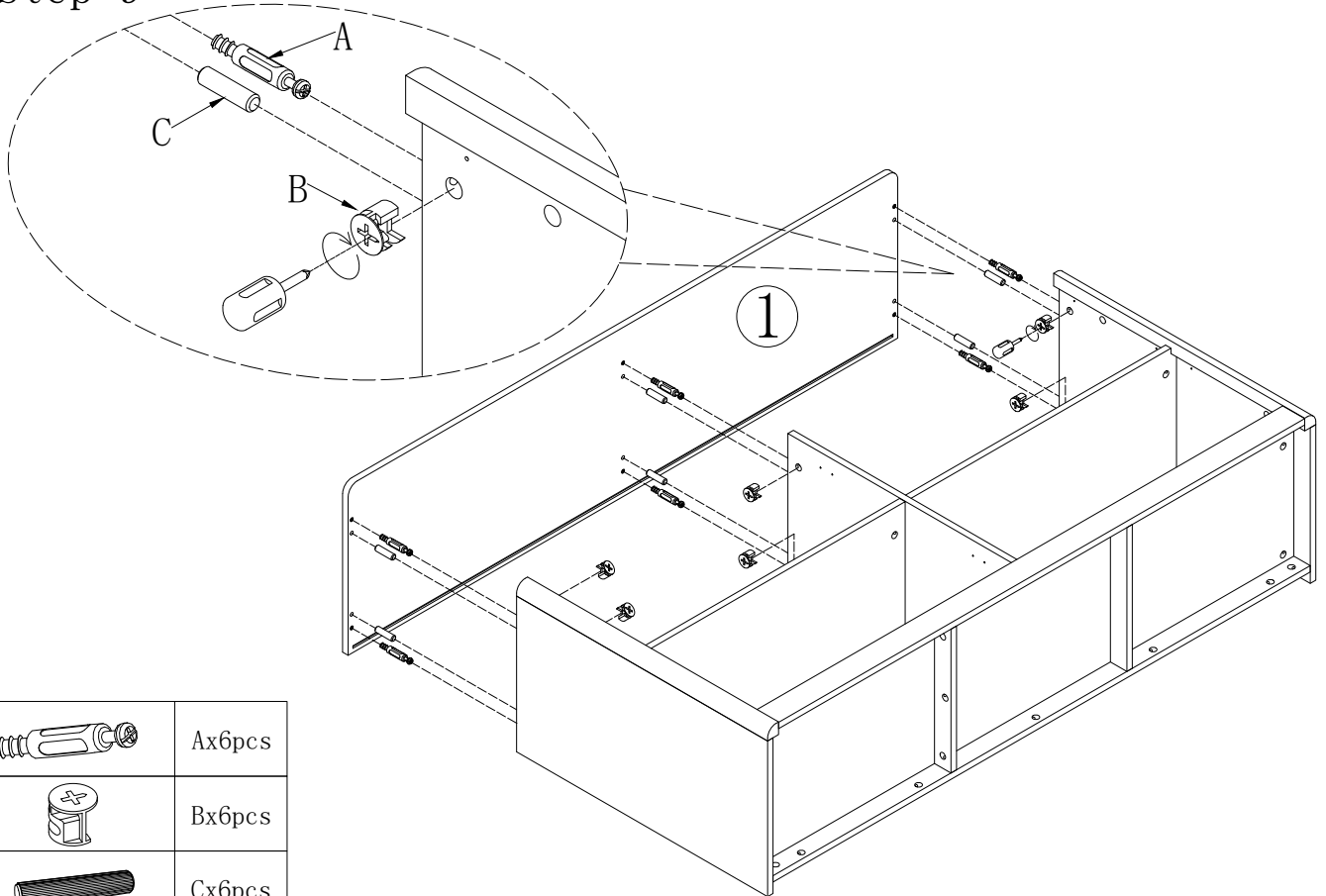
Step 9



	Ax6pcs
	Bx6pcs
	Cx6pcs

Step 10

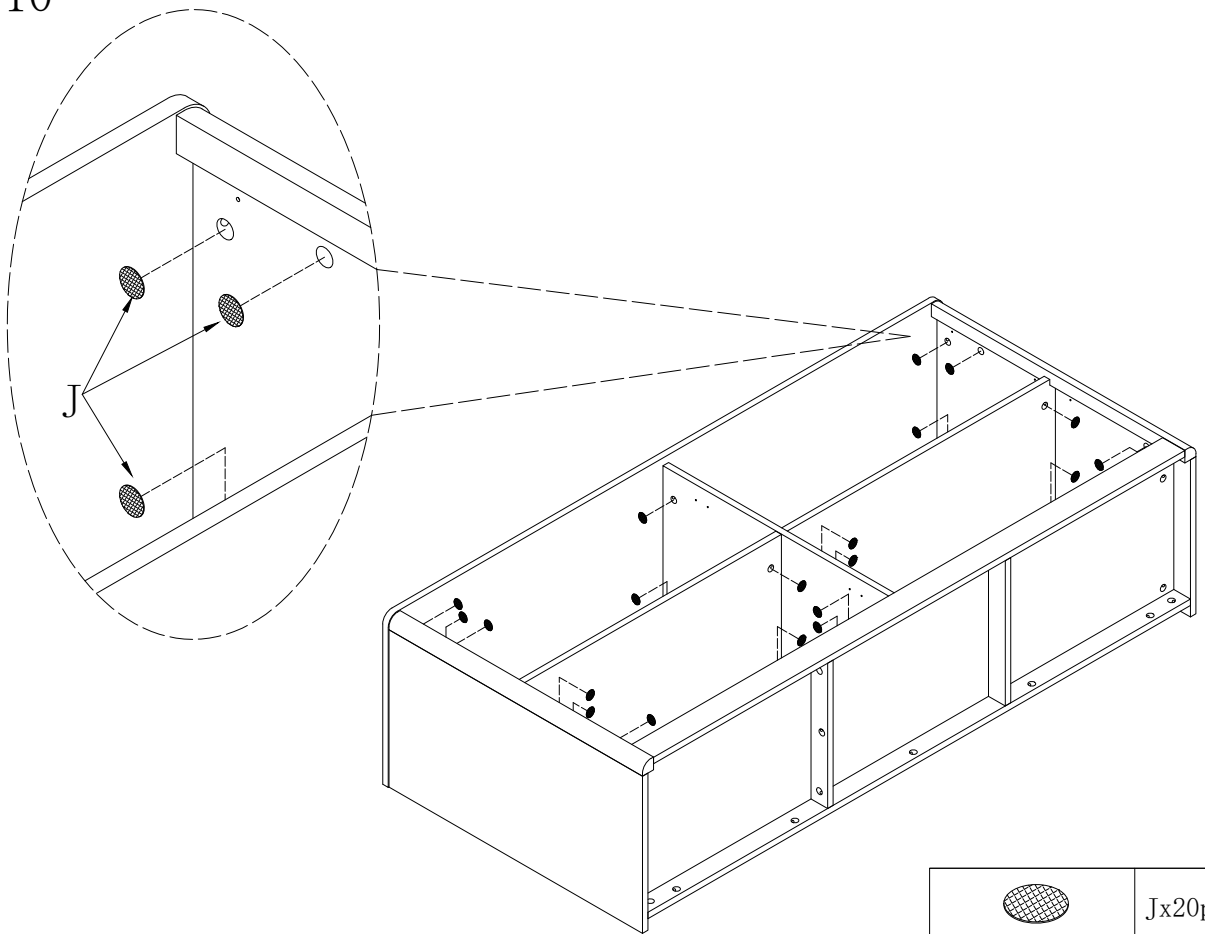

	Jx20pcs
---	---------

Assembly Steps (EN)

Step 11

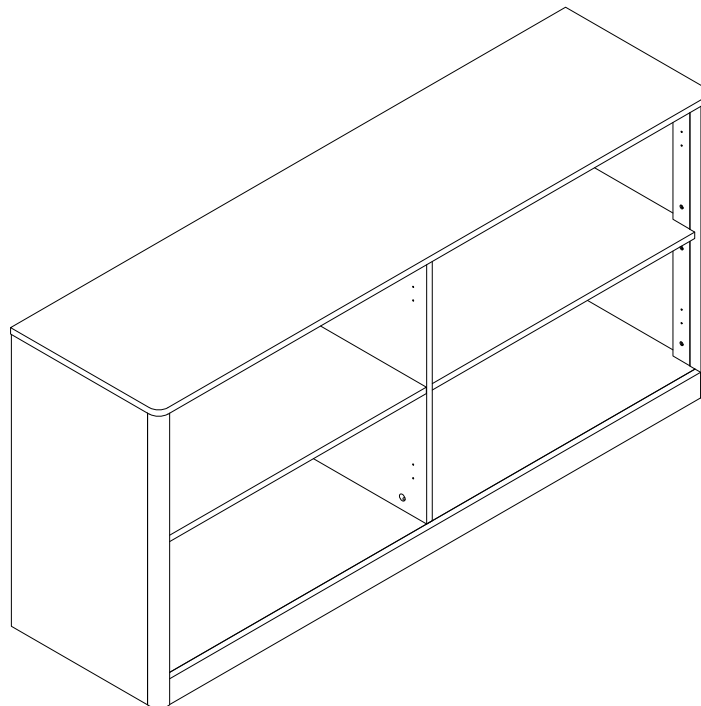
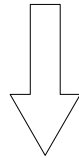
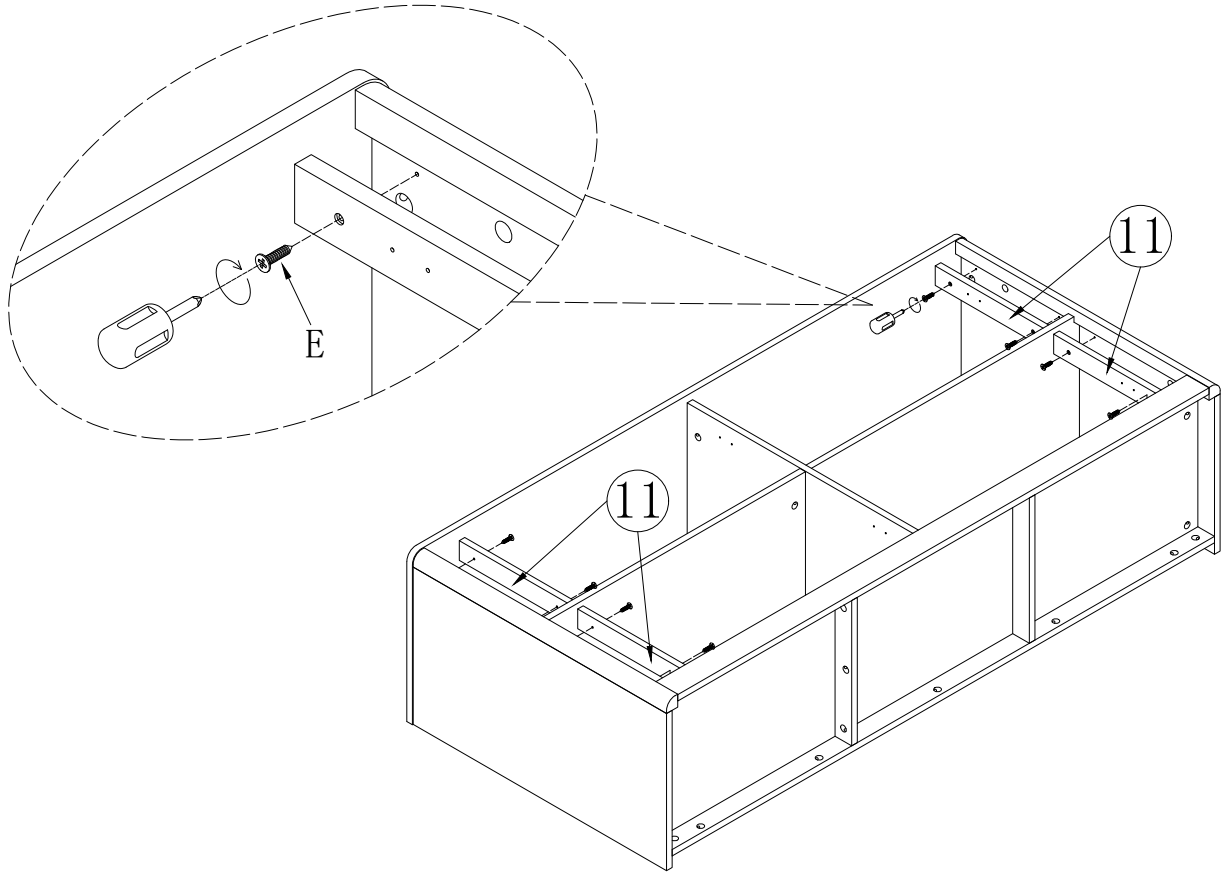

Assembly Steps (EN)

Step 12

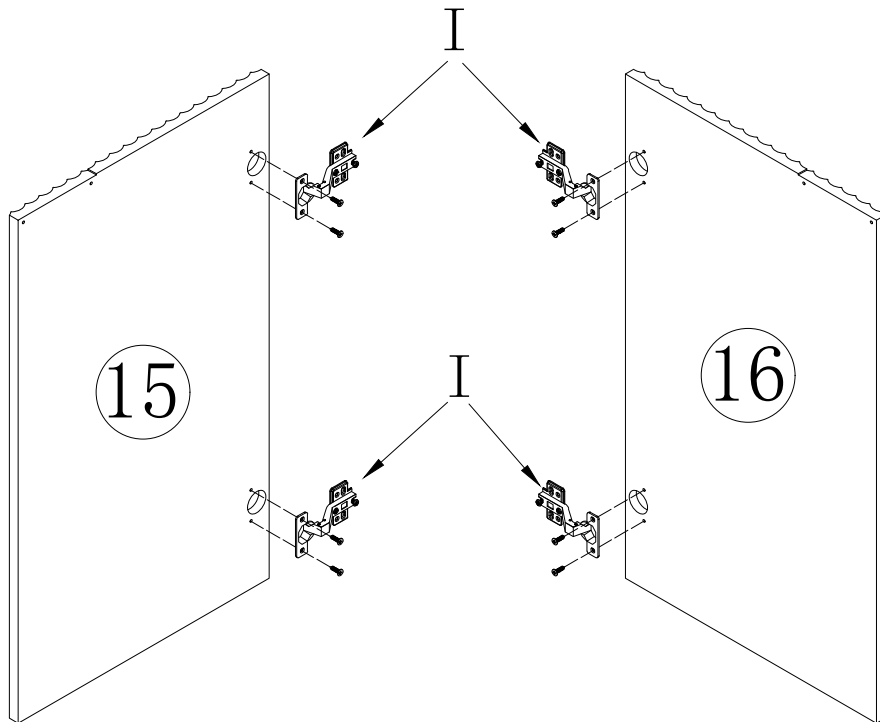
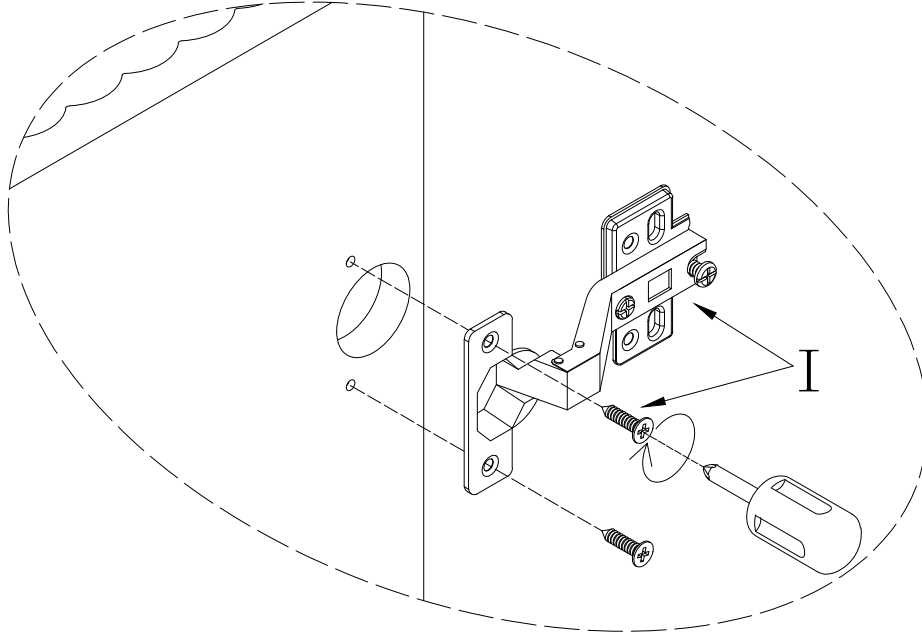

Ix4sets

Assembly Steps (EN)

Step 13

DOOR FITTING

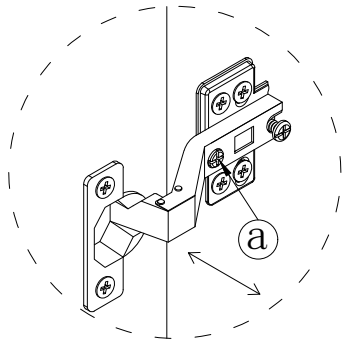

[EN] To adjust in width.
 [FR] Pour régler la largeur.
 [DE] In der Breite anpassen.

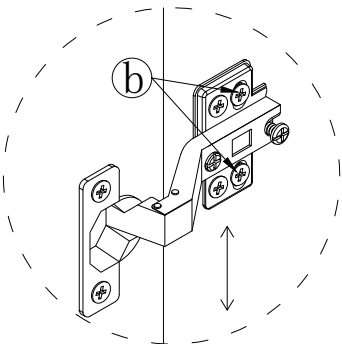

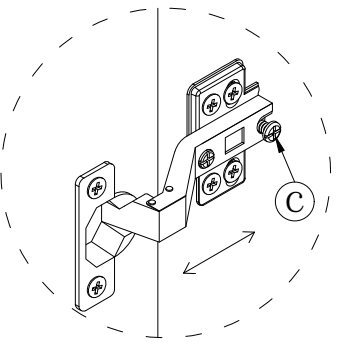

[EN] To adjust in height.
 [FR] Pour régler la hauteur.
 [DE] In der Höhe einstellen.

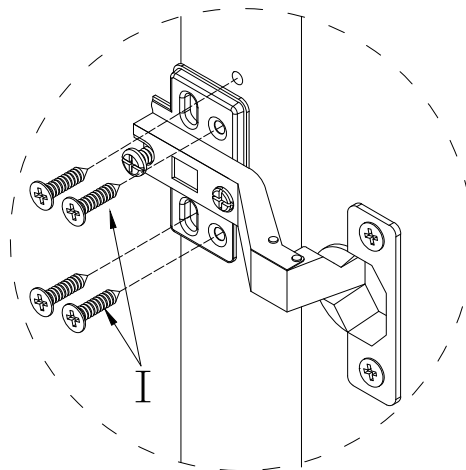
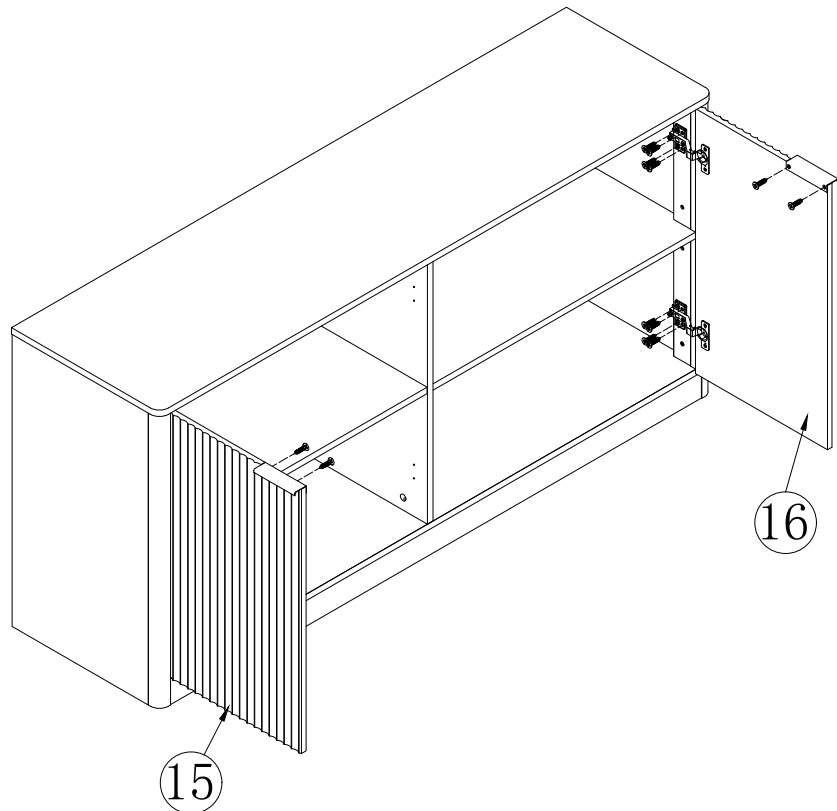
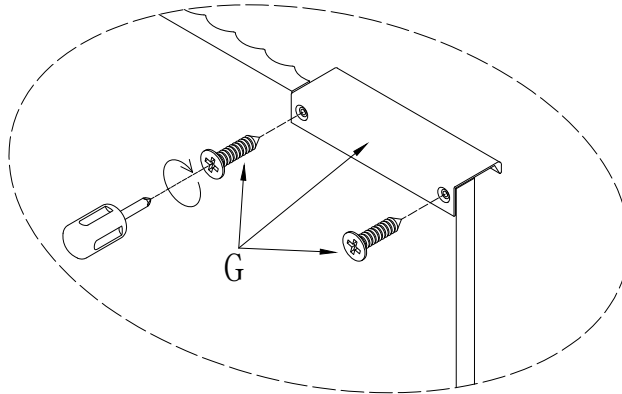

[EN] To adjust in depth.
 [FR] Pour régler en profondeur.
 [DE] Um in der Tiefe anzupassen.



x4

	I x 16 pcs
	G x 2 sets

Assembly Steps (EN)

Step 14

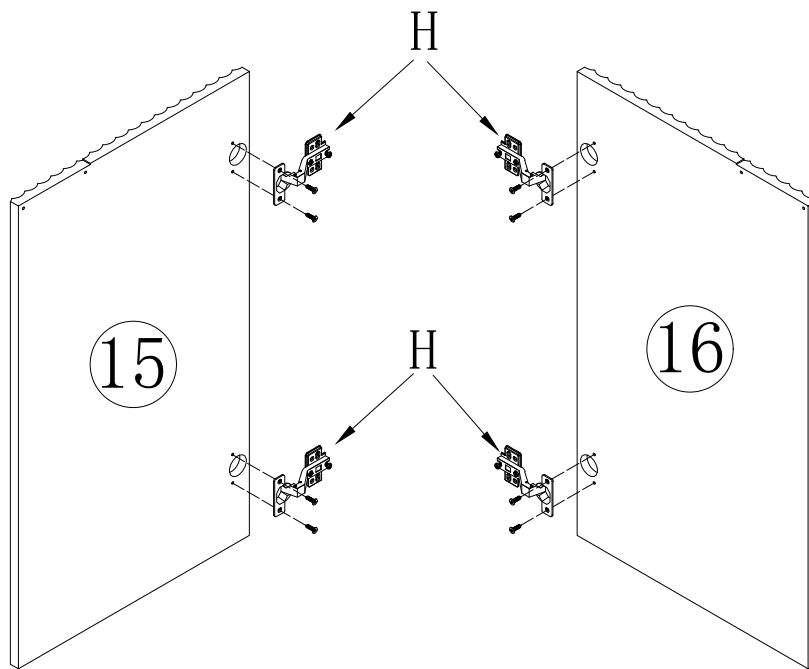
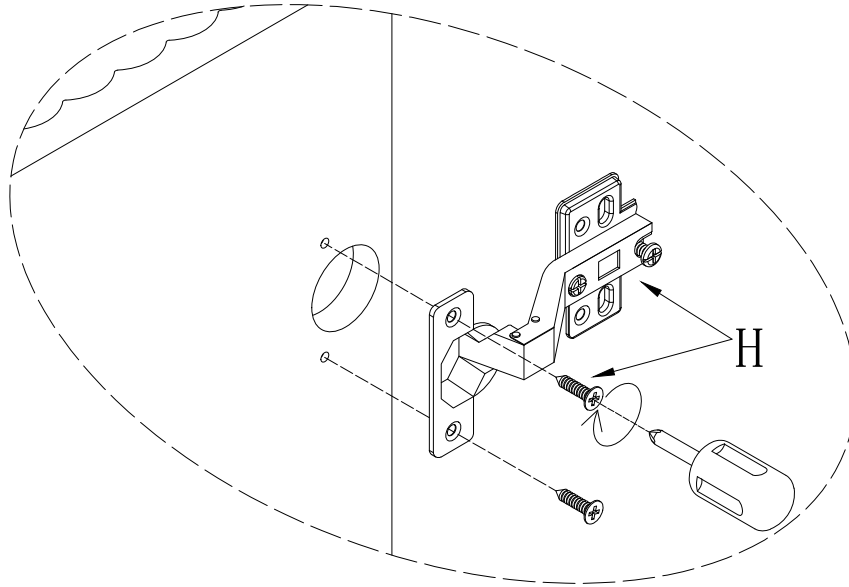

Hx4sets

Assembly Steps (EN)

Step 15

DOOR FITTING

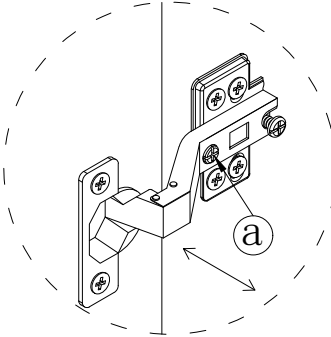

[EN]To adjust in width.
 [FR]Pour régler la largeur.
 [DE] In der Breite anpassen.

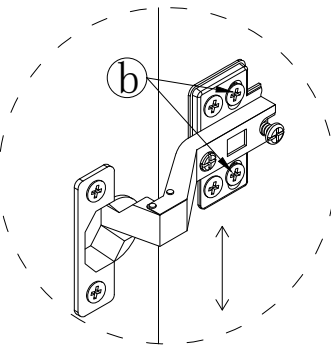

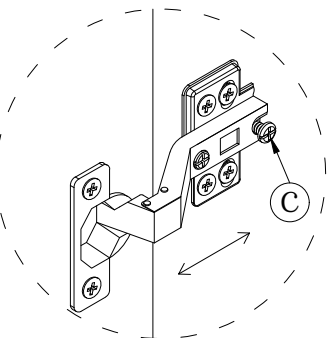

[EN]To adjust in height.
 [FR]Pour régler la hauteur.
 [DE] In der Höhe einstellen.

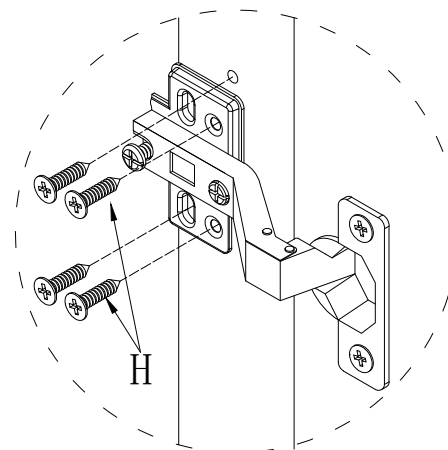
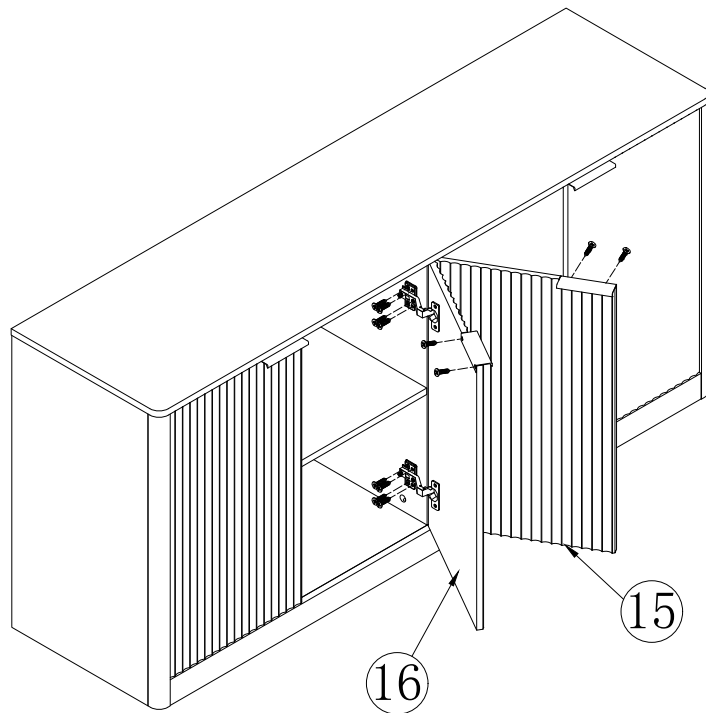
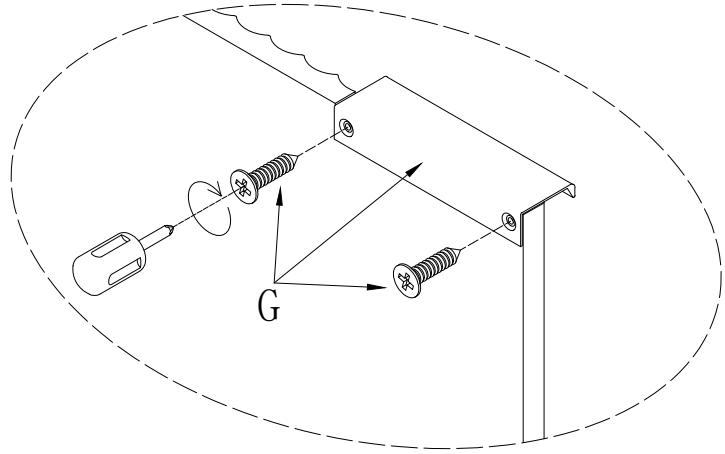

[EN]To adjust in depth.
 [FR]Pour régler en profondeur.
 [DE]Um in der Tiefe anzupassen.



x4



	Hx16pcs
	Gx2sets

Assembly Steps (EN)

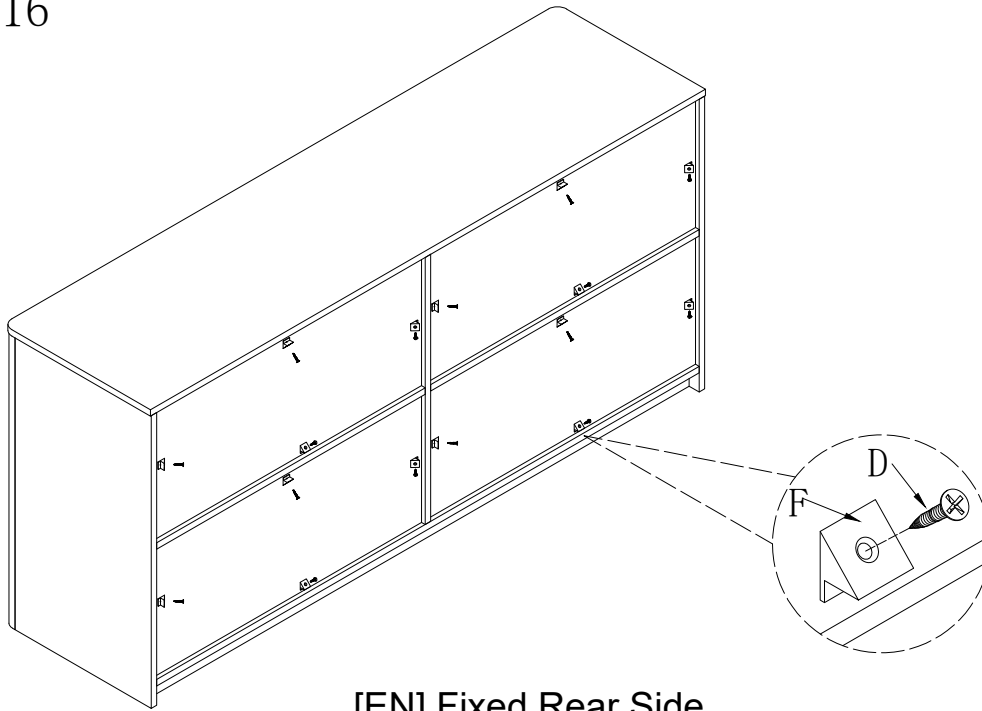
Step 16



[EN] Fixed Rear Side
[FR] Côté arrière fixe
[DE] Feste Rückseite

	Dx16pcs
	Fx16pcs

Step 17

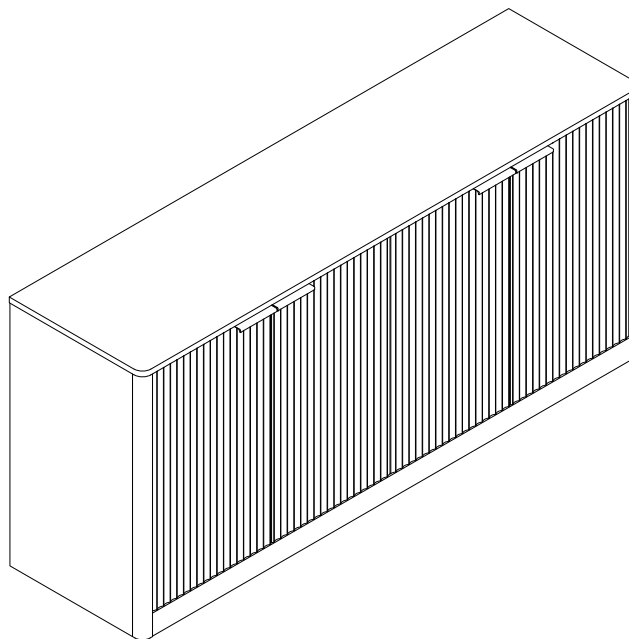

Final