

Laneri[®]

sanitary ware

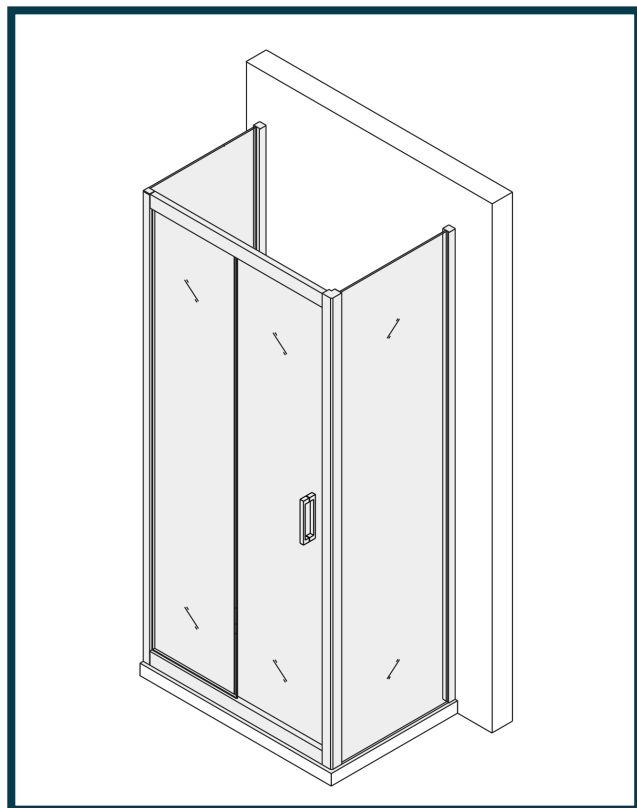
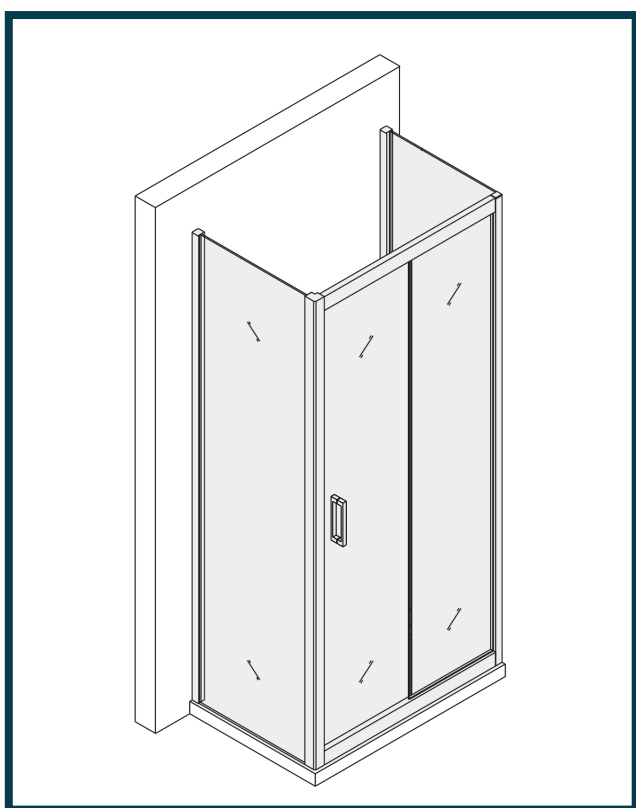

 YouTube LANERI SRL

Seattle 3.0



ITALIANO PAG. 3



FRANÇAIS PAG. 13



DEUTSCH PAG. 23

Seattle 3.0

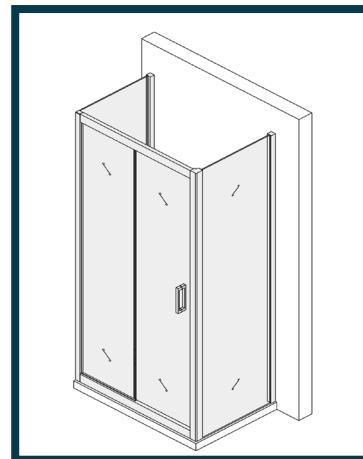
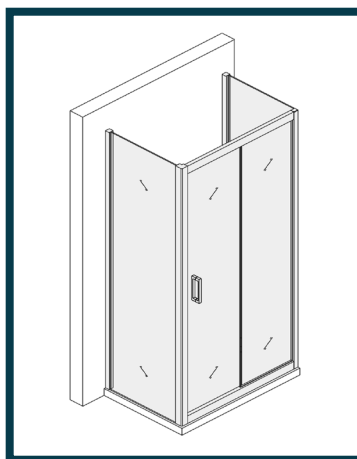

DESCRIZIONE

Box Doccia Scorrevole con 2 pareti fisse laterali h 190 realizzato in vetro 6mm.
Installazione della porta reversibile. Possibilità di sgancio rapido dei carrelli inferiori.
Regolazione manuale dei profili a muro di 2,5 cm per lato.
Telaio in alluminio cromato, Vetro con trattamento anticalcare segnalato da apposite etichette verdi.

ELABORATO TECNICO

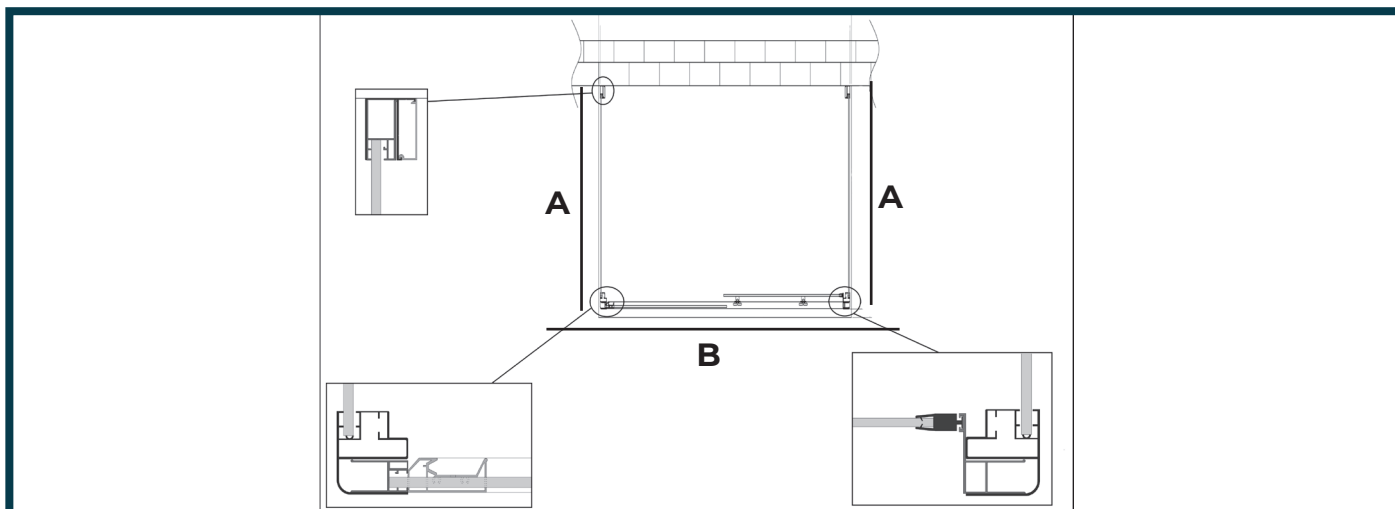

DETTAGLIO PROFILI

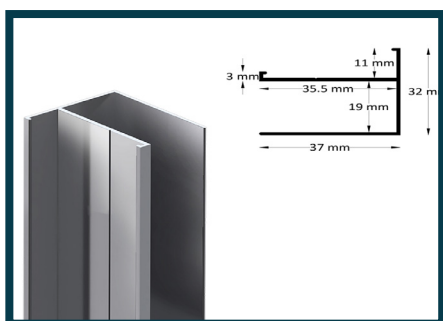

Profilo a muro

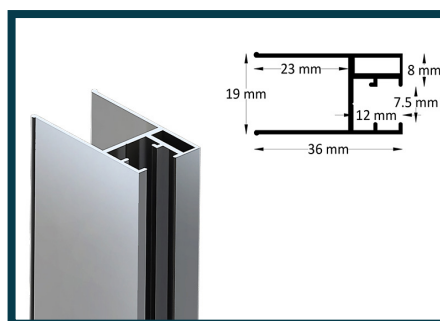

Profilo vetro fisso

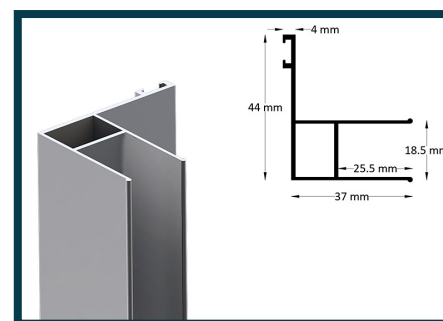

Profilo calamita

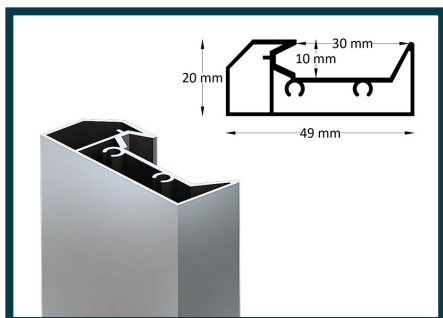

Profilo binario ruote

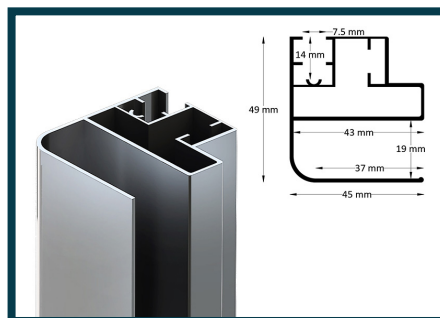

Profilo angolo

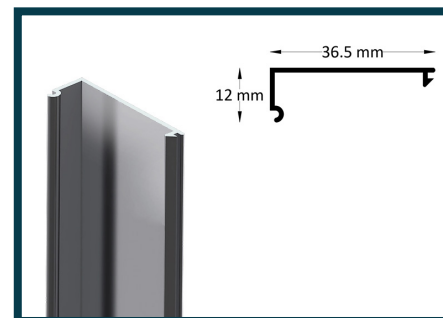

Profilo cover

Laneri®

sanitary ware

c/da Gentilomo snc
94100 Enna Italy
www.laneribagni.it

Seattle 3.0



TABELLA REGOLAGGIO LATO A

PARETI FISSE	REGOLAGGIO A	
	MIN.	MAX.
650	625	650
675	650	675
700	675	700
750	725	750
800	775	800
900	875	900

TABELLA REGOLAGGIO LATO B

PORTA SCORREVOLE	REGOLAGGIO B	
	MIN.	MAX.
1000 (misura traverso 87 cm)	950	1000
1100 (misura traverso 97 cm)	1050	1100
1200 (misura traverso 107 cm)	1150	1200
1300 (misura traverso 117 cm)	1250	1300
1400 (misura traverso 127 cm)	1350	1400
1500 (misura traverso 137 cm)	1450	1500
1600 (misura traverso 147 cm)	1550	1600
1700 (misura traverso 157 cm)	1650	1700

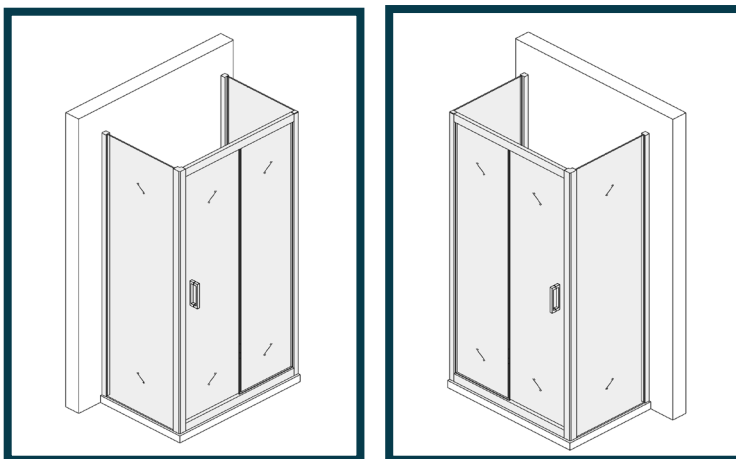
SEATTLE 3.0

UTENSILI NECESSARI



Matita

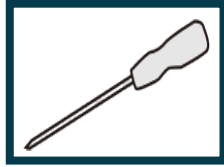

Cacciavite

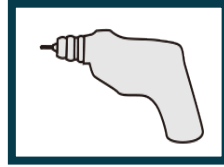

Trapano

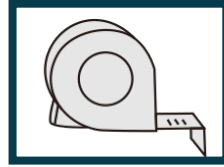

Metro a nastro

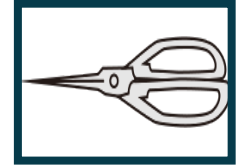

Forbice

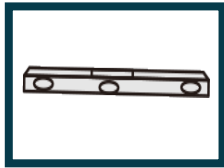

Livello



Chiave esagonale
(in dotazione)

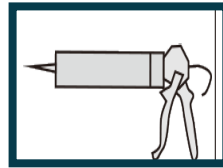

Silicone



Martello di
gomma

CONTENUTO DELLA CONFEZIONE

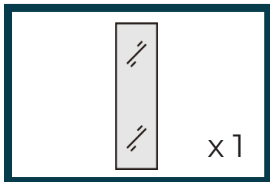

Vetro fisso x 1

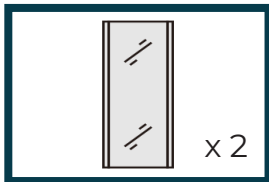

Vetro parete fissa
h 1.90 x 2

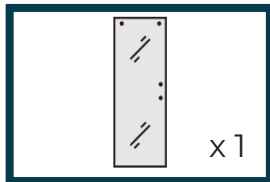

Vetro scorrevole x 1

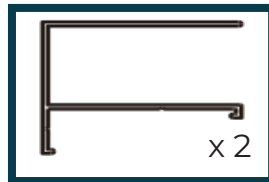

Profilo muro
h 1.90 x 2

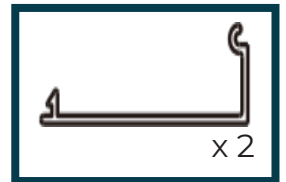

Cover profilo muro
h 1.90 x 2

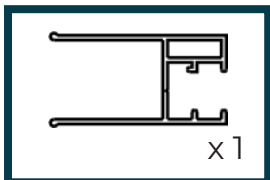

Profilo vetro fisso x 1

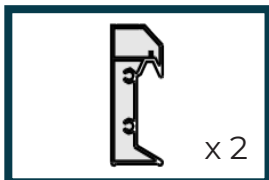

Montante
scorrevole x 2

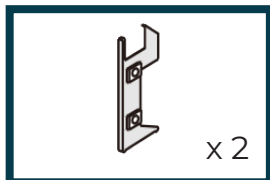

Connettore lato
fisso con asola x 2

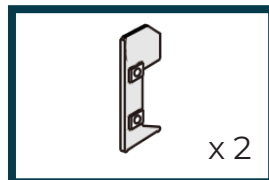

Connettore lato
scorrevole senza asola x 2

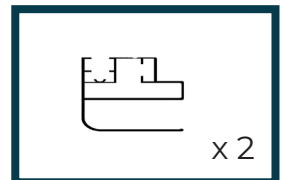

Profilo angolare
h 1.90 x 2



Ruote inferiori
sganciabili x 2



Ruote superiori x 2

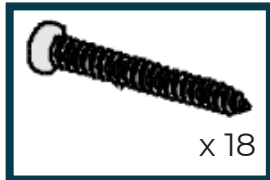

Vite 4 x 30 x 18



Vite 4 x 16 x 4



Vite 4 x 12 x 2

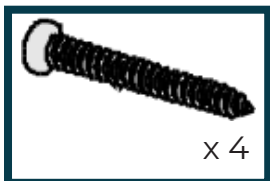

Vite 4 x 20 x 4

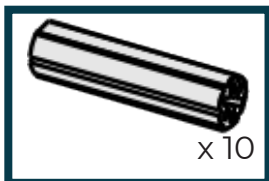

Tassello x 10

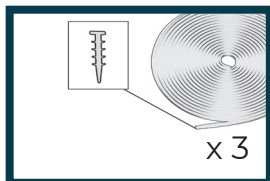

Guarnizione a
rotolo ferma vetro x 3

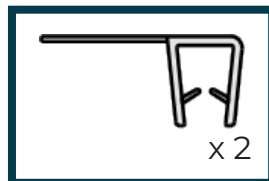

Guarnizione
aletta paraschizzi x 2

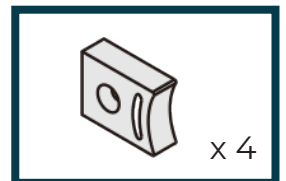

Fine corsa x 4

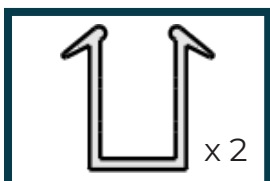

Guarnizione
protezione vetri x 2

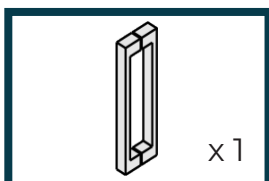

Maniglia x 1

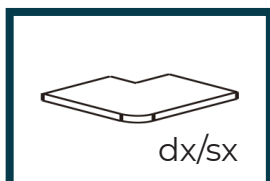

Cover profilo
angolare dx/sx

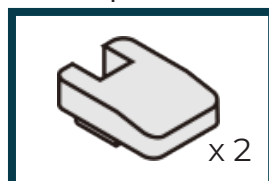

Cover x 2

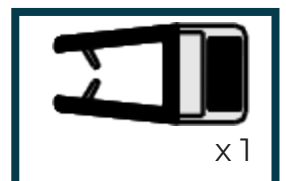

Guarnizione
calamita x 1

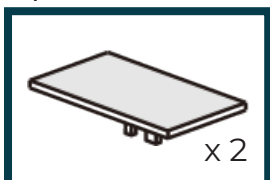

Cover superiore
ferma vetro fisso x 2

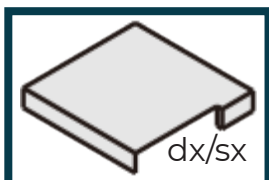

Cover superiore
profilo muro dx/sx

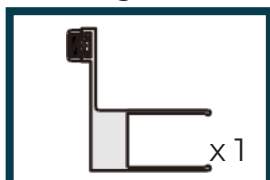

Profilo calamita h
1.90 x 1

MONTAGGIO

1° PASSAGGIO

1. Verificare la messa in bolla del piatto doccia con il livello.
2. Poggiare il profilo a muro ed utilizzare il livello per la messa a piombo.
3. Tracciare i fori a muro con la matita.
4. Praticare i fori a muro con il trapano.
5. Inserire il tassello a muro e avvitare le viti per fissare il profilo.

IMPORTANTE

è buona norma non montare i profili a ridosso del bordo esterno del piatto doccia, lasciare sempre circa 1 cm per un risultato estetico ottimale

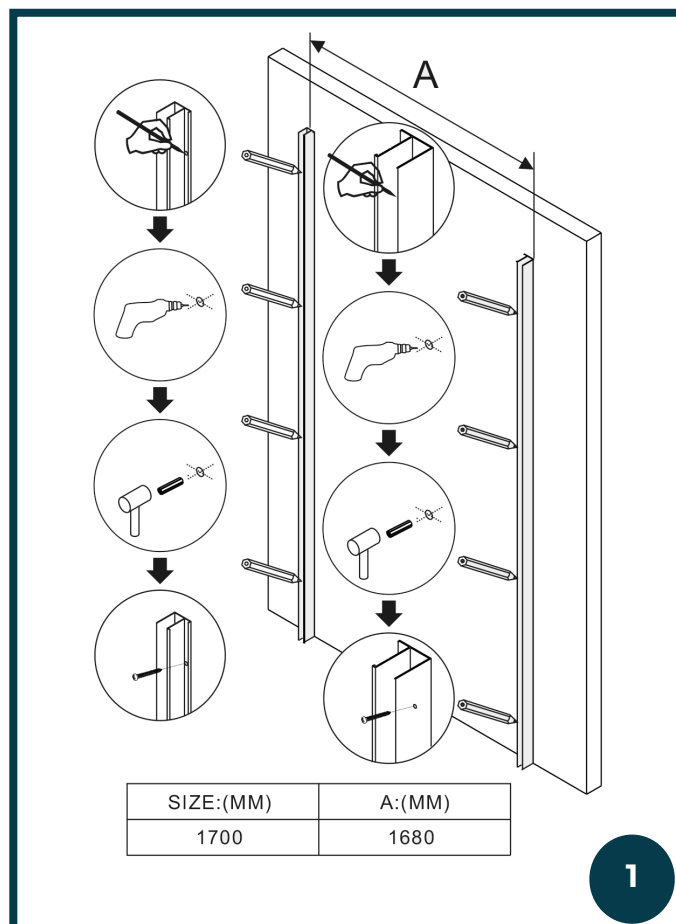

1

2° PASSAGGIO

1. Usare la vite 4x30 per collegare il binario in alluminio inferiore con il profilo verticale. In questo modo costruiamo il telaio della porta (scheletro).

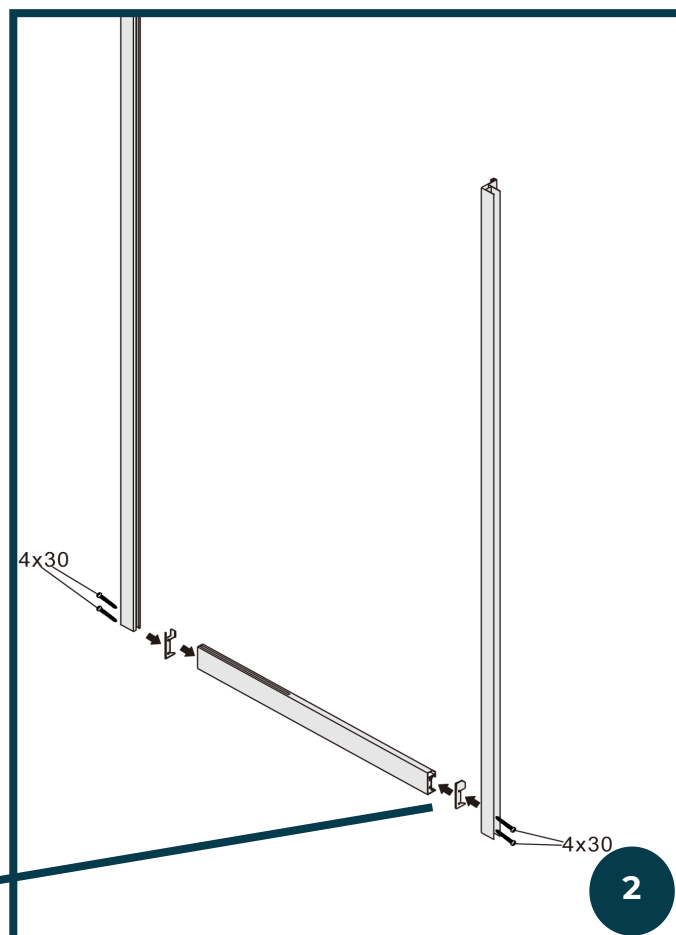
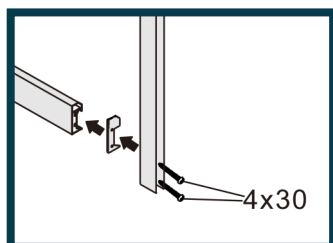

2

3° PASSAGGIO

1. Mettere le parti in plastica nel binario di alluminio come in figura A. (cover)
2. Posizionare la guarnizione nel profilo inferiore. Come in figura A.
(Guarnizione protezione vetri)
3. Inserire il vetro fisso come in figura B.

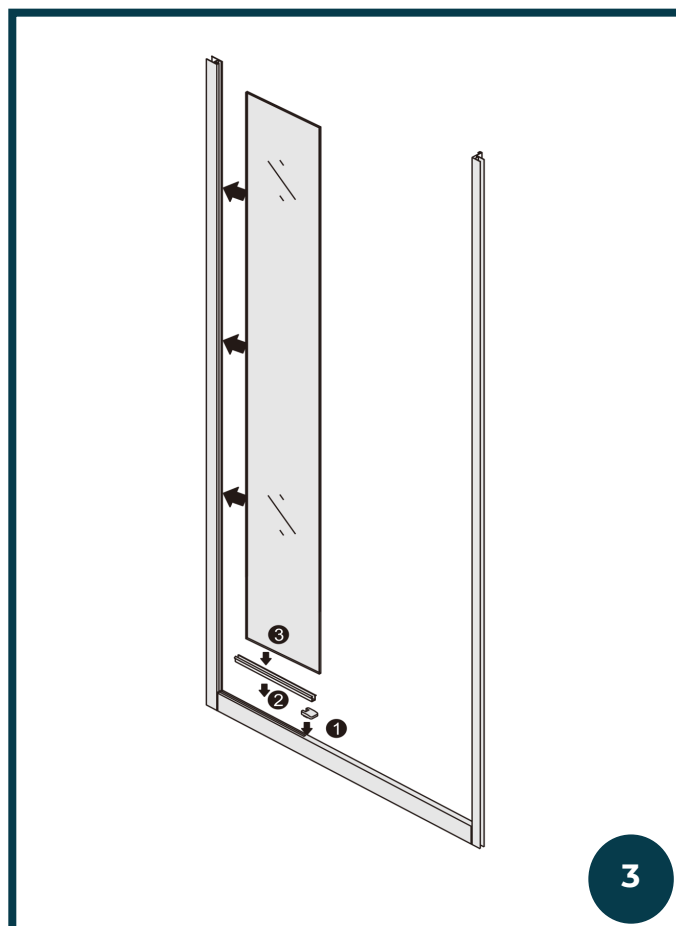
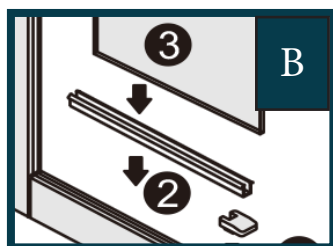
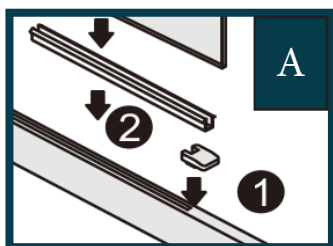

4° PASSAGGIO

1. Ripetere il passaggio (2 e 3) precedente per la parte alta del telaio

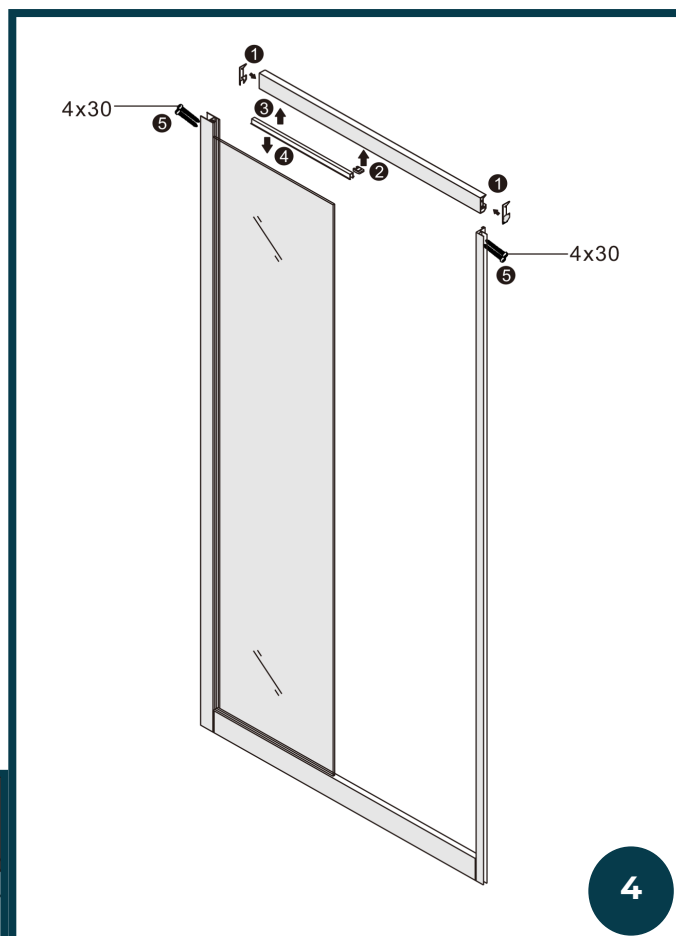
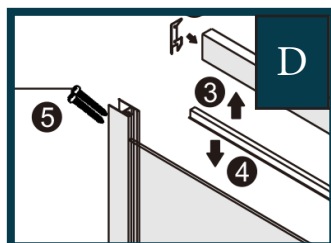
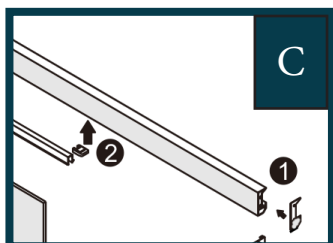

5° PASSAGGIO

1. Applicare il silicone nell'insenatura dei profili ad angolo.
2. Inserire i vetri fissi all'interno dei profili ad angolo e mentre fresco completare il passaggio successivo (6)

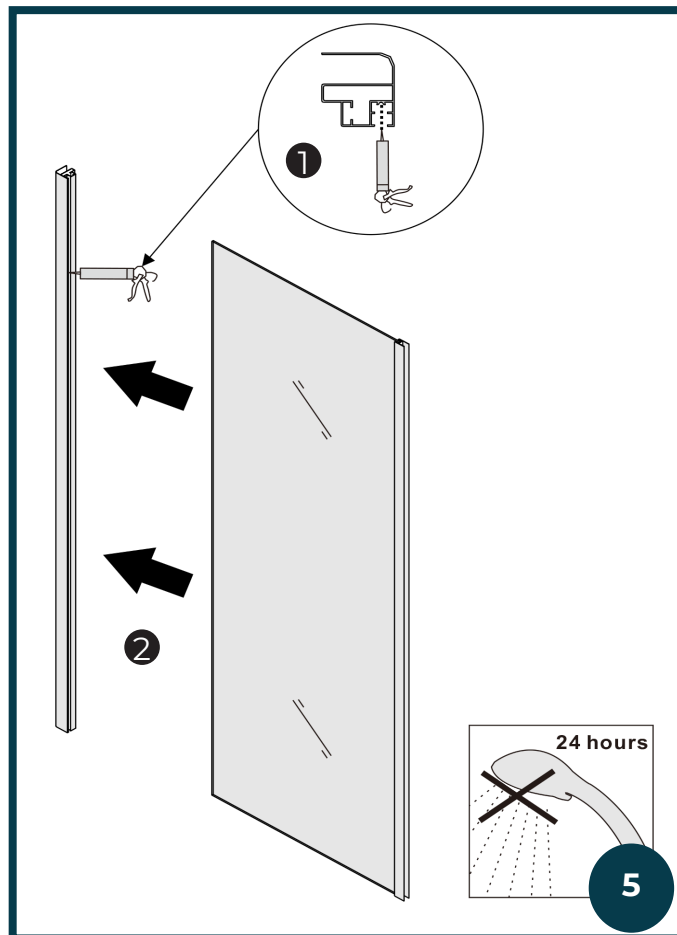

6° PASSAGGIO

1. Installare le guarnizioni ferma vetro tra il vetro e il profilo in alluminio ad angolo avendo cura di inserirle dal basso verso l'alto.
2. le guarnizioni da usare sono quelle arrotolate nelle bustine, vanno inserite a pressione tra vetro e telaio.

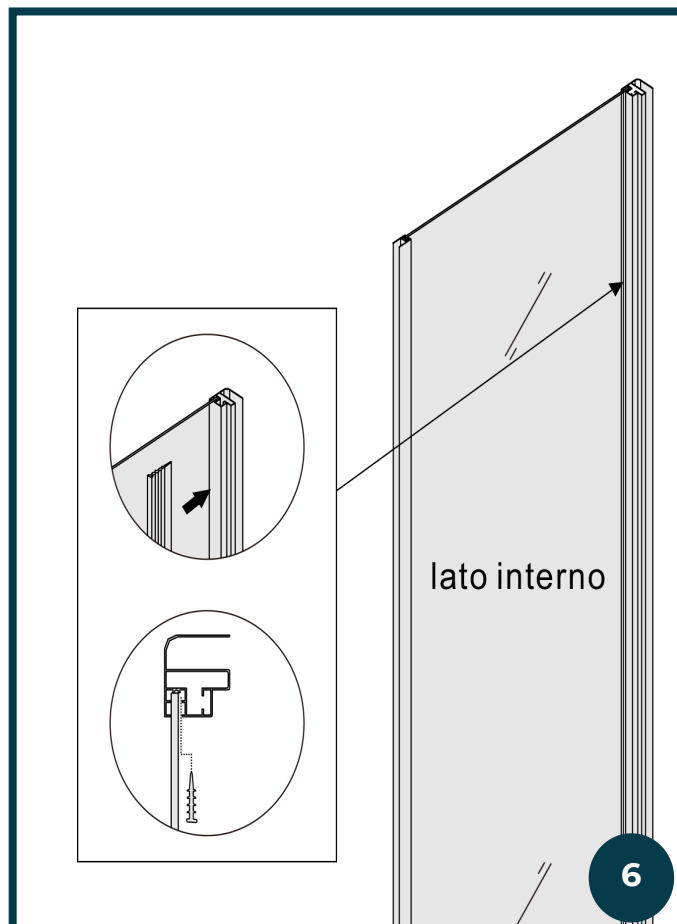

7° PASSAGGIO

1. Inserire le pareti fisse tra i profili a muro e il profilo in alluminio della porta anteriore.

IMPORTANTE:

Per una corretta installazione consigliamo di rimuovere il profilo muro dalla parete, di inserirlo sulla parete fissa in vetro per poi poggiare sul piatto l'assieme, fisserete il profilo muro in un secondo momento.

NOTA BENE:

sotto la lastra fissa non ci va nulla, va poggiata e siliconata dall'esterno.

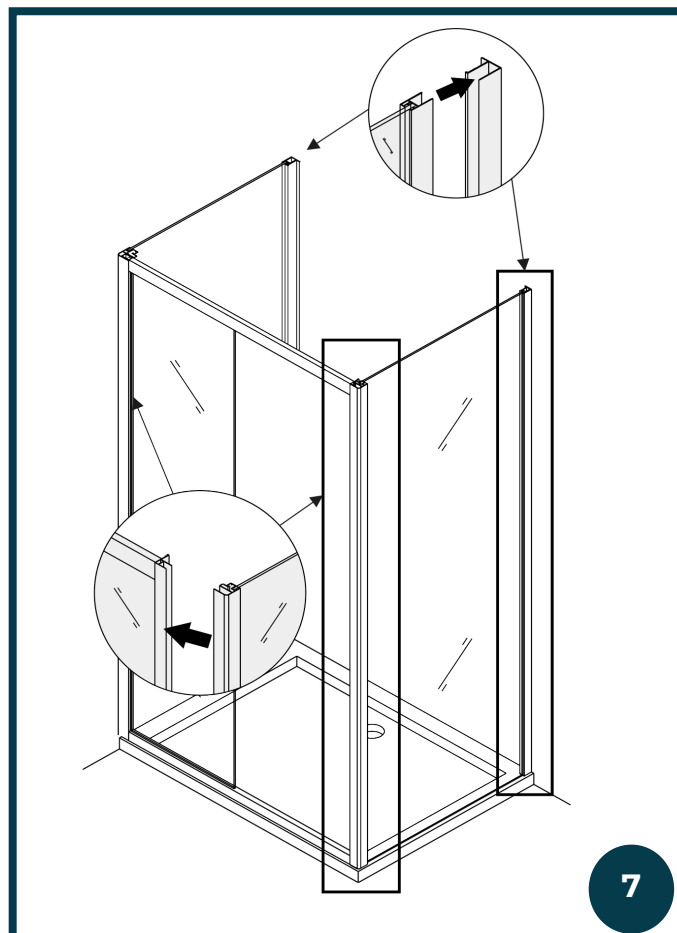

7

8° PASSAGGIO

1. Installare le rotelle di scorrimento inferiori (con pulsante per sgancio rapido) e superiori.

Nota: le **ruote superiori** sono regolabili, se, dopo aver montato il box doccia, le ante non dovessero avere uno scorrimento fluido è possibile regolarle tramite la vite inferiore sul cuscinetto superiore.

Le ruote di scorrimento inferiori sono sganciabili per facilitare le operazioni di pulizia e manutenzione ordinaria.

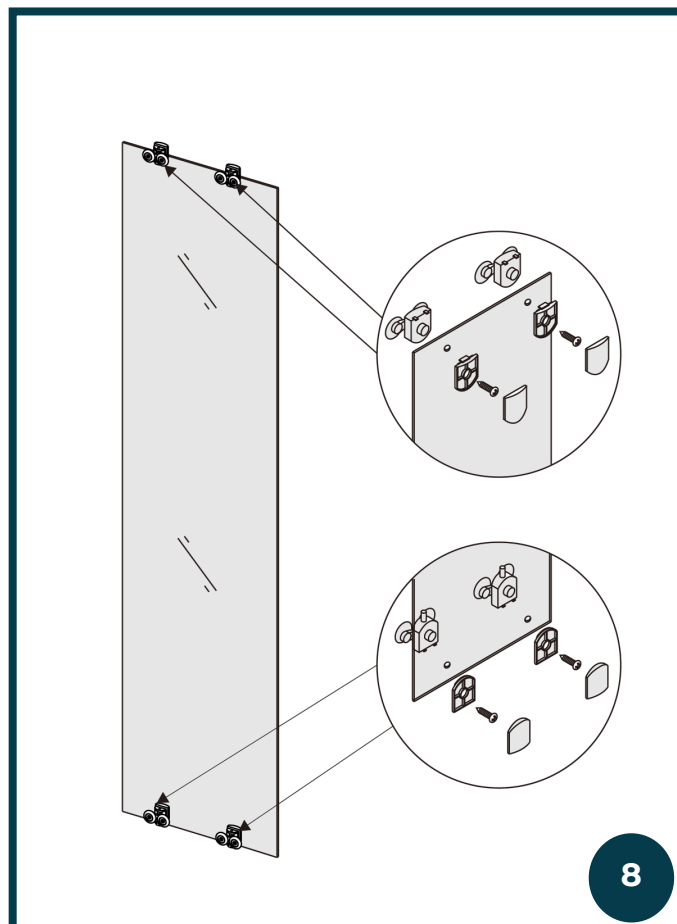

8

9° PASSAGGIO

1. Agganciare le ante al binario di scorrimento. Accertarsi che la porta sia in asse, vedi passaggio precedente per regolarle.

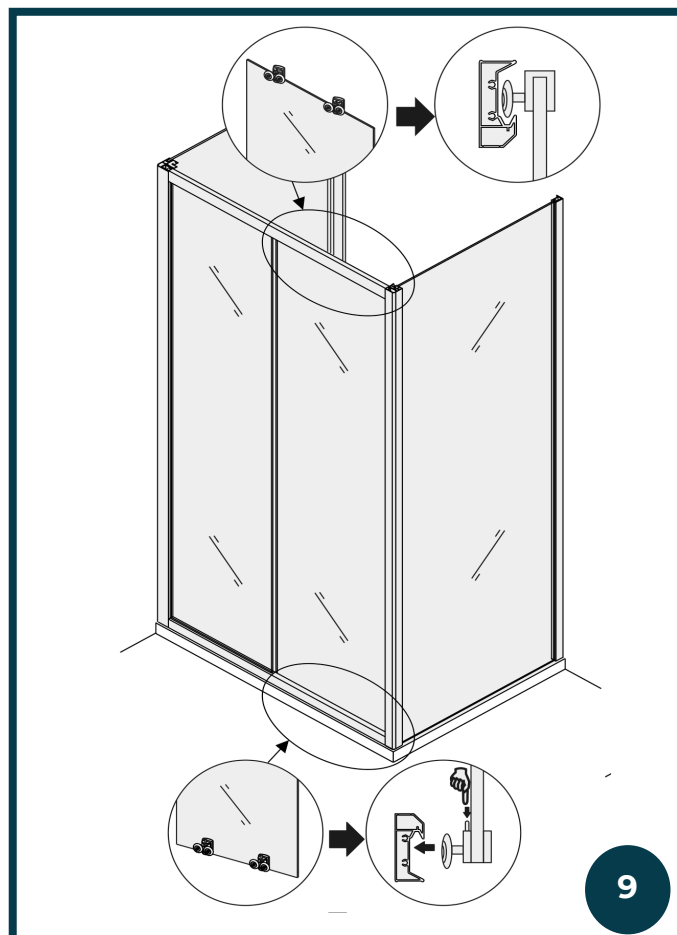

10° PASSAGGIO

1. Installare la guarnizione magnetica di chiusura sulla porta.
2. Correggere e mettere a piombo le pareti, dunque praticare dei fori e applicare le viti dal lato interno per bloccare il box ai profili a muro, dunque ricoprire con il profilo decorativo in alluminio i due profili a muro per nascondere i fissaggi.
3. Collegare i profili in alluminio ad angolo con la porta frontale scorrevole usandole viti 4 x 20 (praticare il foro prima con l'ausilio del trapano).

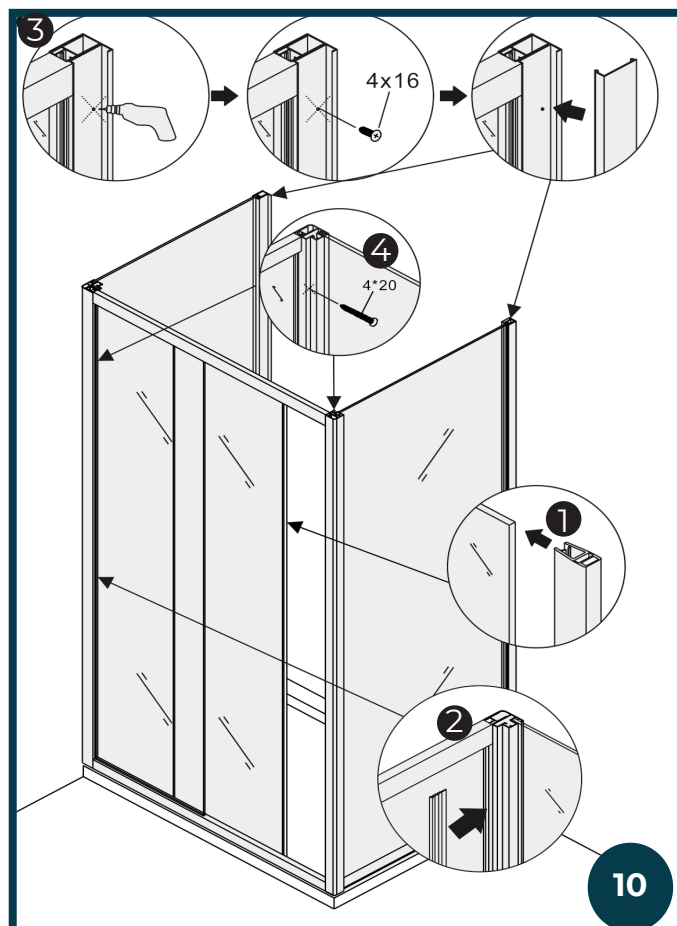

11° PASSAGGIO

1. Installare il fine corsa sul binario sopra e sotto. Usare le viti piu' piccole che vi sono in dotazione , altrimenti si rischia di bucare il lato a vista del binario di scorrimento
2. Installare la maniglia.
3. Installare le guarnizioni di tenuta tra vetro fisso e porta scorrevole.

ATTENZIONE

In dotazione c'è una guarnizione più alta ed una più bassa , quella più bassa va sul vetro fisso , quella più alta nel vetro scorrevole .

4. Installare I Tappini Di Copertura Nella Parte Superiore Del Profilo In Alluminio E Siliconare La Parte Esterna Del Box Doccia Lungo Tutto Il Perimetro Come Mostrato In Figura.

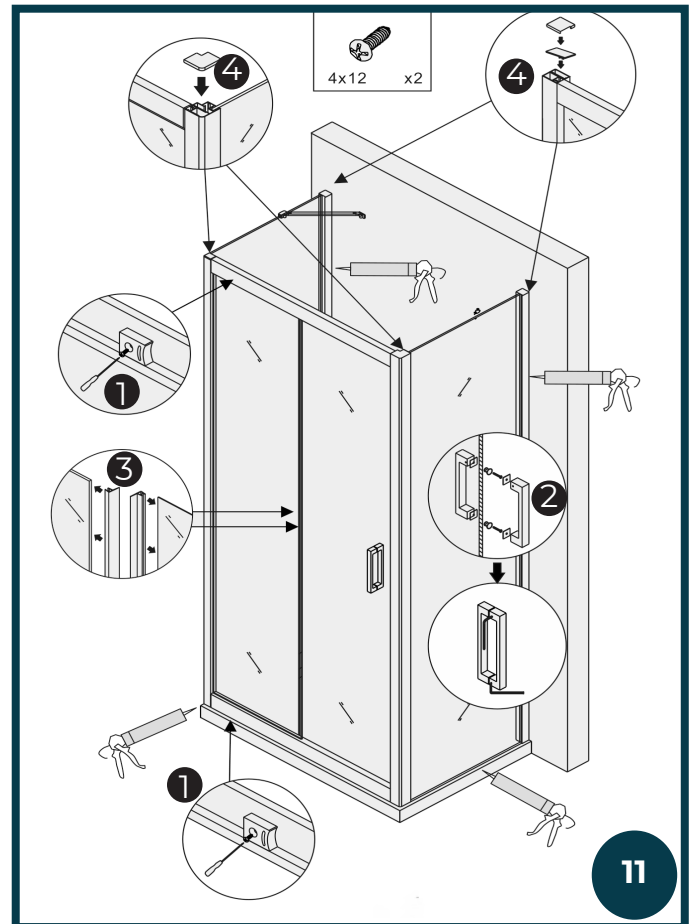

Laneri®

sanitary ware

c/da Gentilomo snc
94100 Enna Italy
www.laneribagni.it

Seattle 3.0

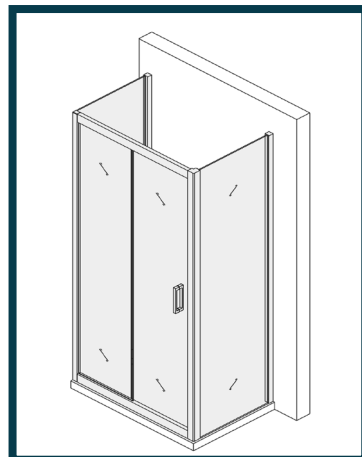
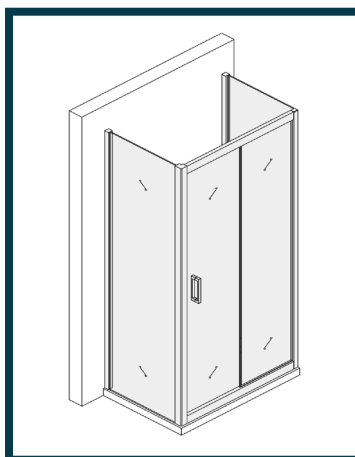

DESCRIPTION

Douche coulissante avec deux paroi fixe laterale h 190 en verre trempé de 6mm.
Installation reversible. Roulements inférieur détachables. Réglage jusqu'à 2.5 cm grace aux profilés murales.
Châssis en aluminium chromé anti-calcaire, verre anti-calcaire signalé avec étiquette verte.

SPÉCIFICATION TECHNIQUE

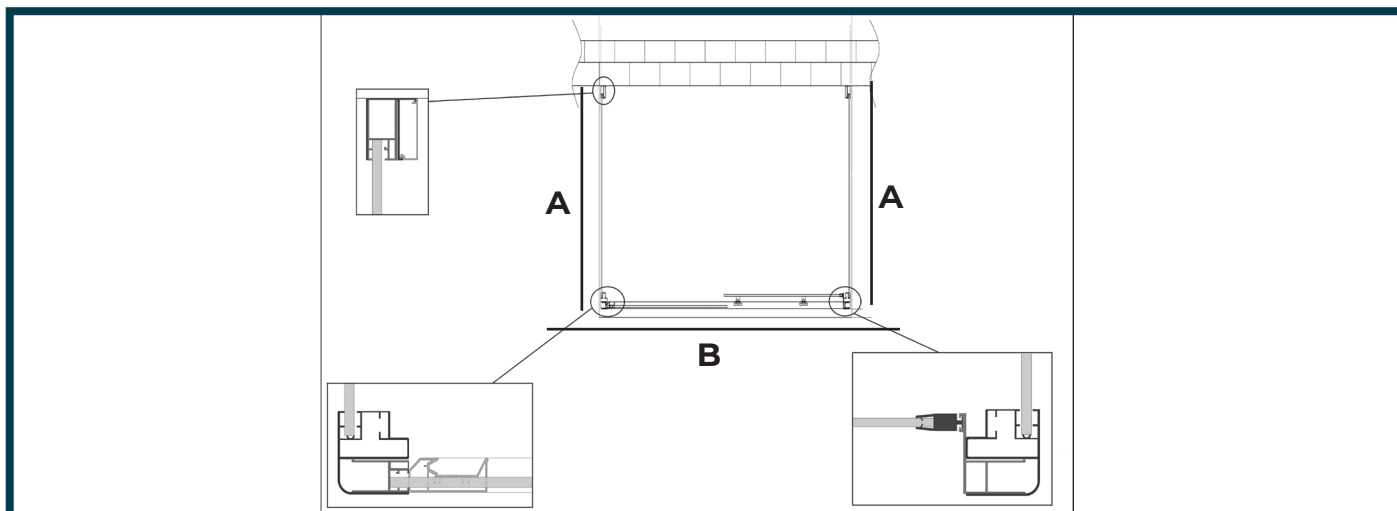

PROFILÉS EN DÉTAIL

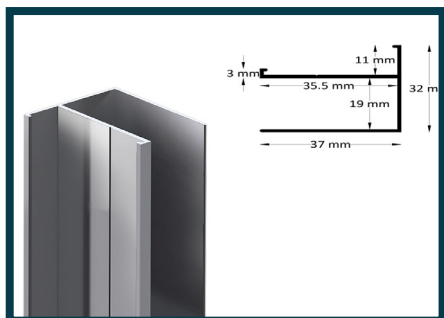

Profilé mural fixe

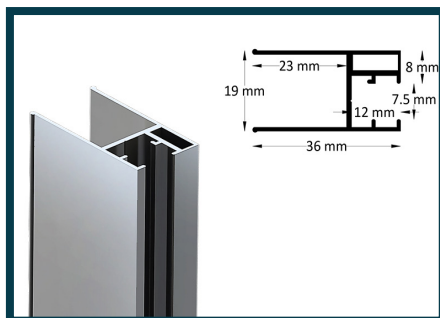

Profilé pour le verre fixe

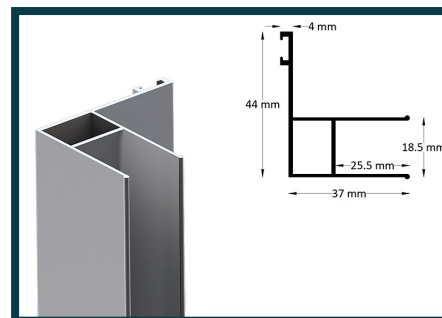

Joint magnétique pour porte coulissante

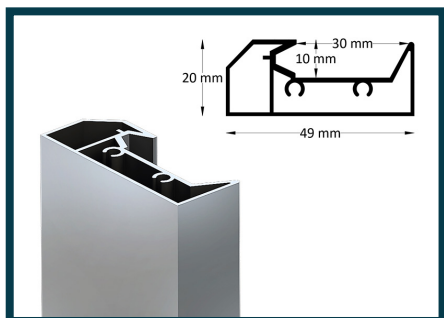

Joint pour rail des roulements

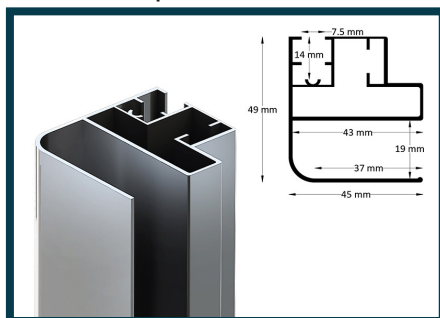

Profilé angulaire

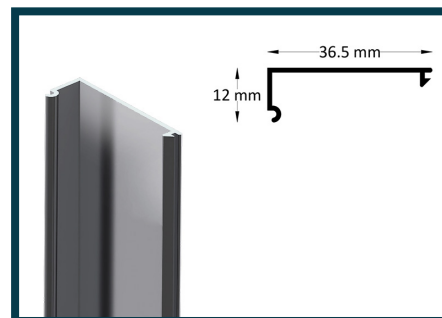

Profilé de couverture

Laneri®

sanitary ware

c/da Gentilomo snc
94100 Enna Italy
www.laneribagni.it

Seattle 3.0

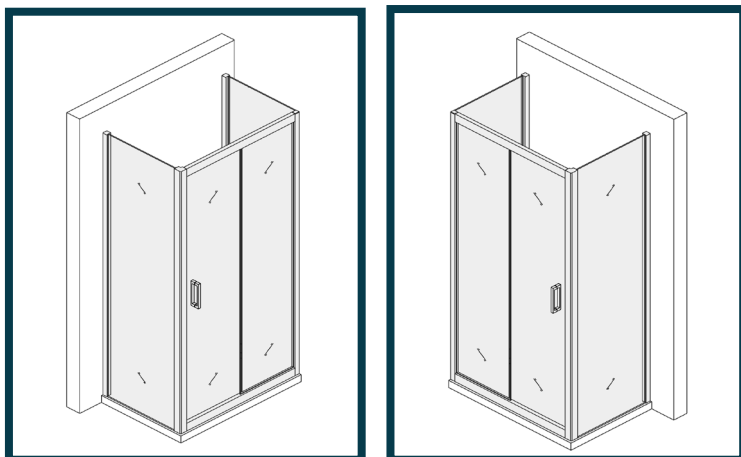

FICHE DE RÉGLAGE - CÔTÈ A

PAROI FIXE	RÈGLAGE A	
	MIN.	MAX.
650	625	650
675	650	675
700	675	700
750	725	750
800	775	800
900	875	900

FICHE DE RÉGLAGE - CÔTÈ B

PORTE COULISSANTE	RÈGLAGE B	
	MIN.	MAX.
1000 (Mesure de la barre 87 cm)	950	1000
1100 (Mesure de la barre 97 cm)	1050	1100
1200 (Mesure de la barre 107 cm)	1150	1200
1300 (Mesure de la barre 117 cm)	1250	1300
1400 (Mesure de la barre 127 cm)	1350	1400
1500 (Mesure de la barre 137 cm)	1450	1500
1600 (Mesure de la barre 147 cm)	1550	1600
1700 (Mesure de la barre 157 cm)	1650	1700

SEATTLE 3.0

USTENSILES NECESSAIRES



Crayon

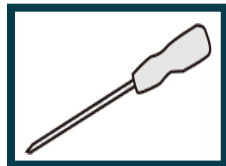

Tournevis

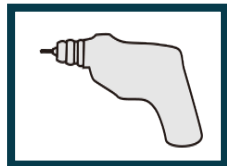

Forage

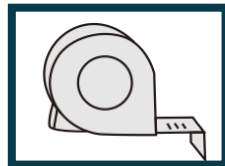

Ruban à mesurer

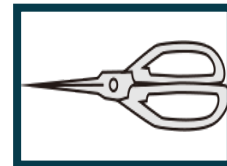

Ciseaux

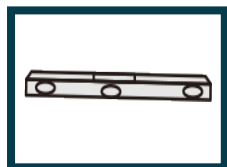

Niveau

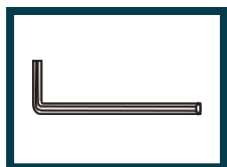

Clé à douille
(en dotation)

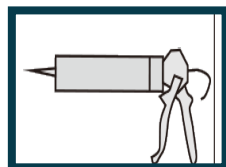

Silicone



Maillet en ca-
outchouc

ACCESSOIRES INCLUS DANS LE COLIS

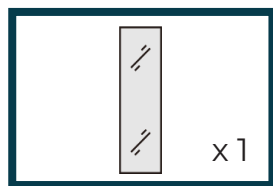

Verre fixe

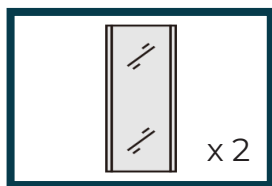

Verre de la paroi
fixe h 1.90

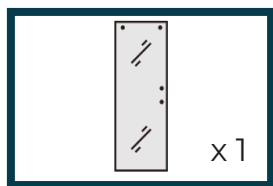

Verre coulissante

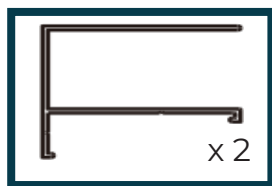

Profilé mural h 1.90

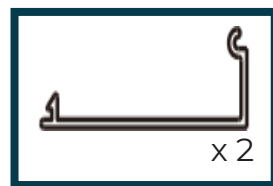

Profilé de couver-
ture h 1.90

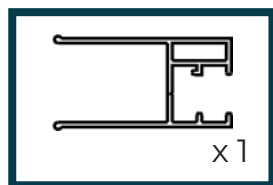

Profilé pour le verre
fixe



Rail pour le coulis-
ement

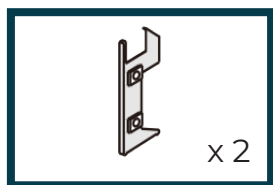

Raccord du verre
fixe avec boucle

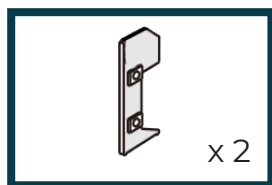

Raccord du verre fixe
sans boucle

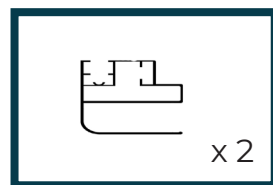

Profilé angulaire h
1.90

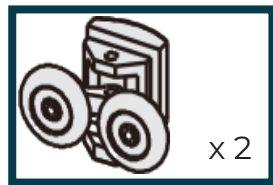

Roulements in-
férieurs détachables

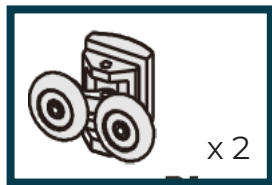

Roulements
supérieurs

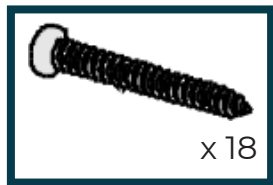

Vis 4 x 30

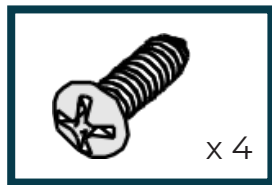

Vis 4 x 16



Vis 4 x 12

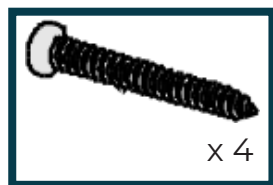

Vis 4 x 20

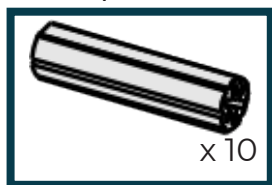

Morceaux

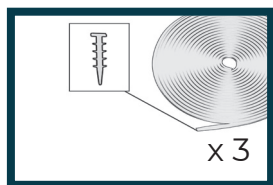

Joint enroulé pour
bloquer le verre

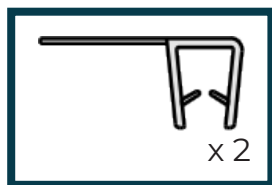

Joint d'étanchéité
avec ailette

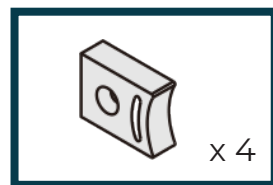

Butée

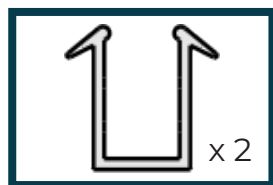

Joint de protection

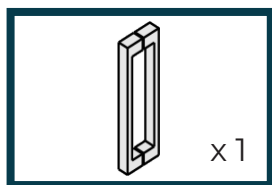

Poignée

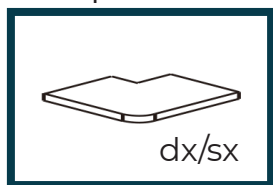

Couverture du pro-
filé angulaire

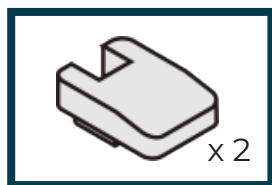

Couverture



Joint magnétique

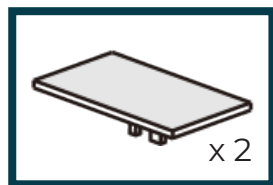

Couverture supérieur
pour bloquer le verre fixe

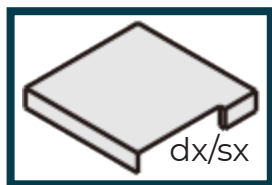

Couverture supérieur
du profilé mural

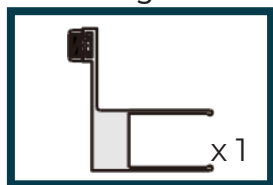

Joint magnétique
h 1.90

Installation

1° ÉTAPE

1. Vérifiez le nivellement du receveur de douche avec le niveau.
2. Appuyez le profilé mural et utiliser le niveau pour la mise à plombe.
3. Tracer les trous sur le mur avec le crayon.
4. Faites le trous avec le forage.
5. Placez les morceaux et vissez les vis pour le fixer sur la paroi.

IMPORTANT:

Nous recommandons de pas installer le profilé à proximité du bord extérieur du receveur de douche, mais de laisser au moins 1 cm du bord, pour une installation optimale.

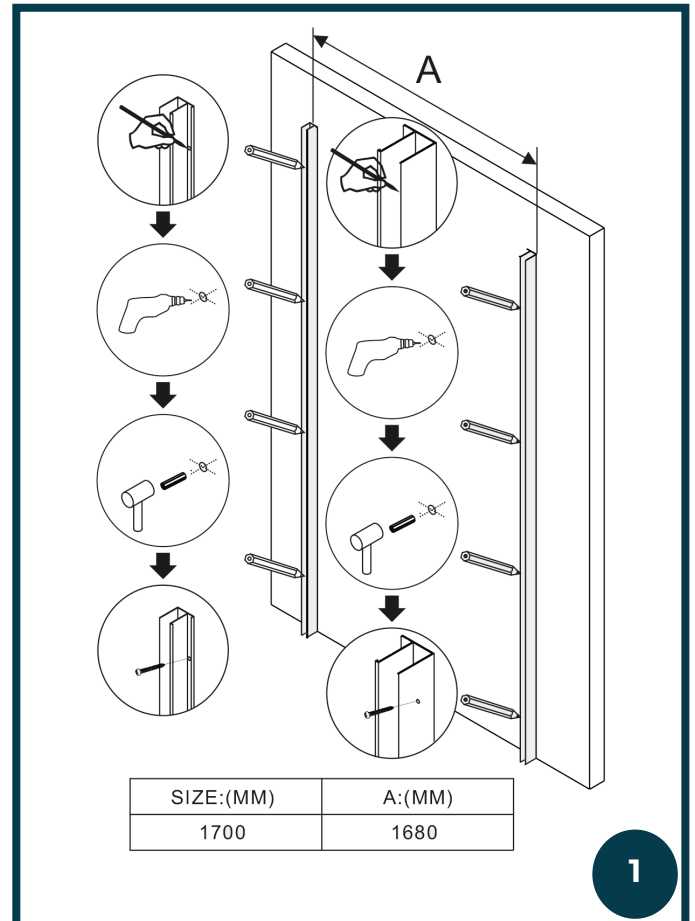

1

2° ÉTAPE

1. Utiliser la vis 4x30 pour connecter le rail inférieur en aluminium avec le profilé vertical. De cette manière vous construirez le châssis de la porte (squelette).

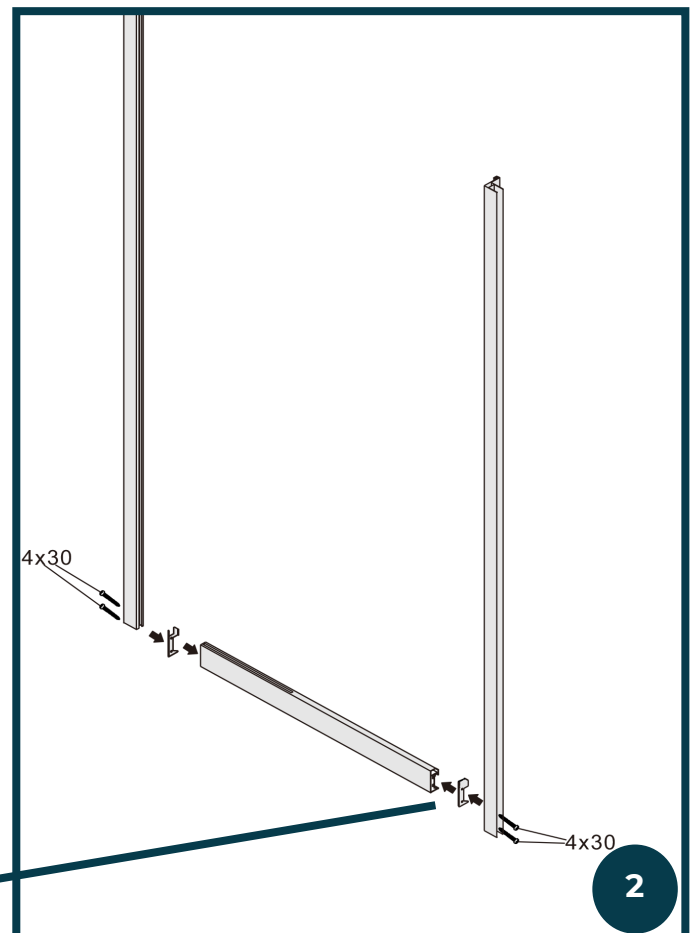
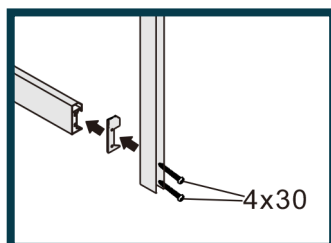

2

3° ÉTAPE

1. Mettre les composants en plastique dans le rail en aluminium selon l'illustration A. (couverture)
2. Placer le joint dans le profilé inférieur . Selon l'illustration A. (Joint de protection)
3. Insérer le verre fixe selon l'illustration B.

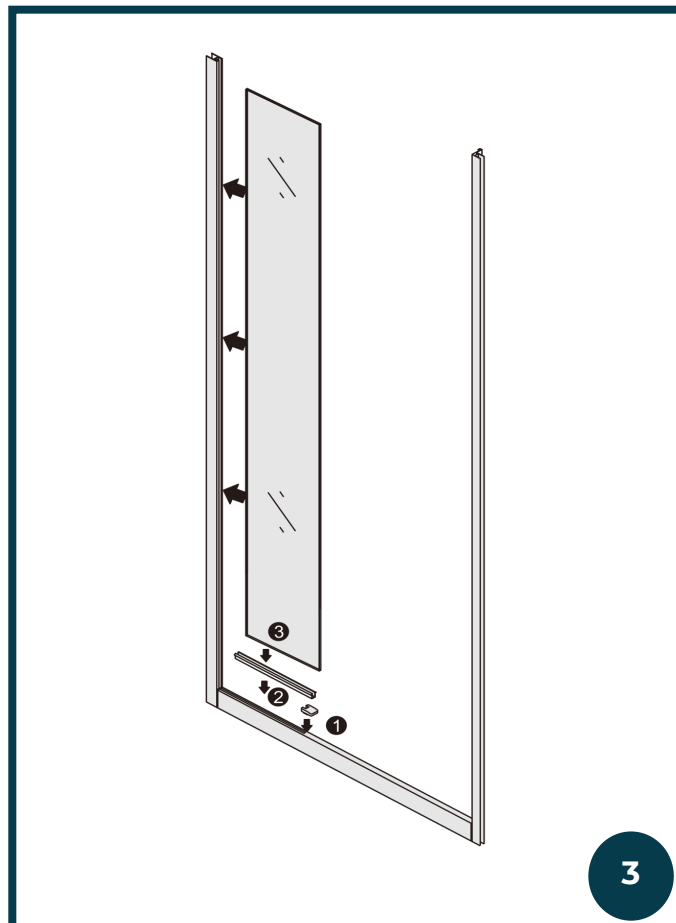
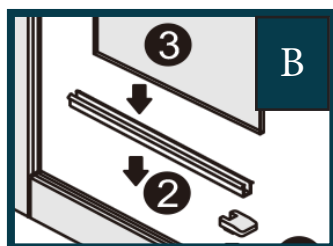
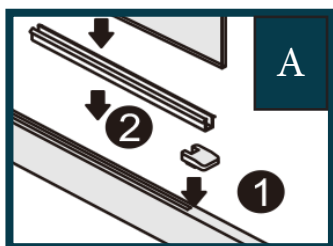

4° ÉTAPE

1. Répétez l'étape (2 e 3) pour l'installation de la partie supérieur du châssis.

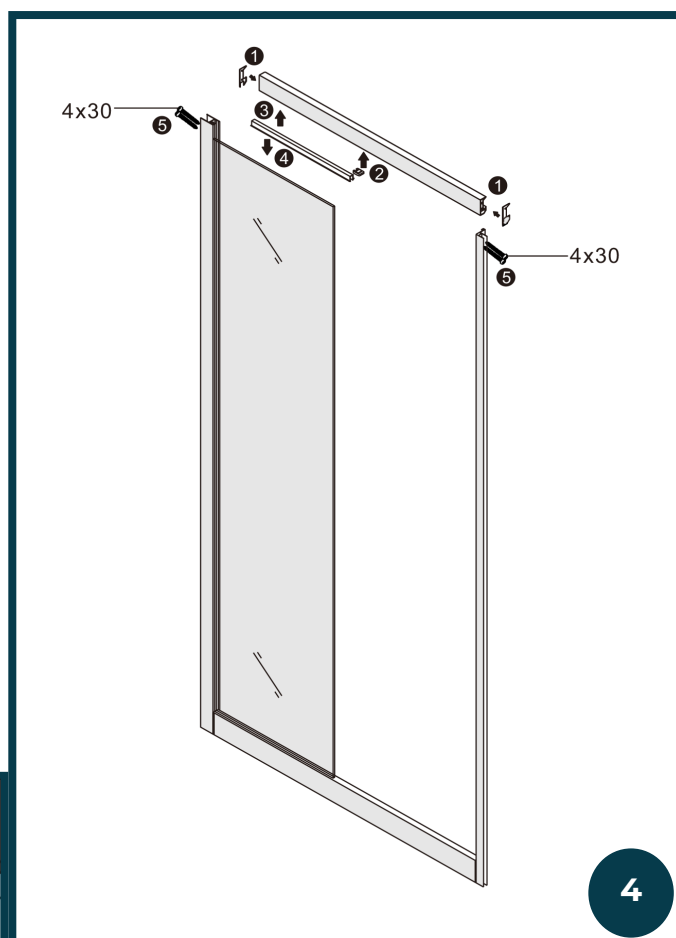
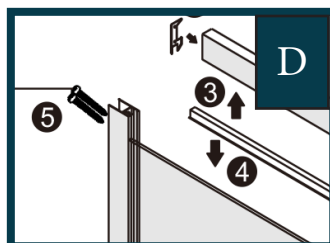
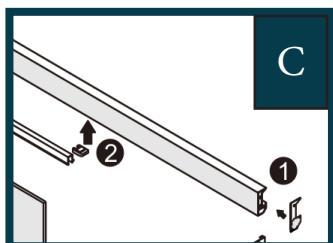

5° ÉTAPE

1. Appliquez le silicone dans la crique du profilé angulaire.
2. Insérez le verre fixe dans le profilé angulaire et pendant que le silicone est frais complétez l'étape suivante (6)

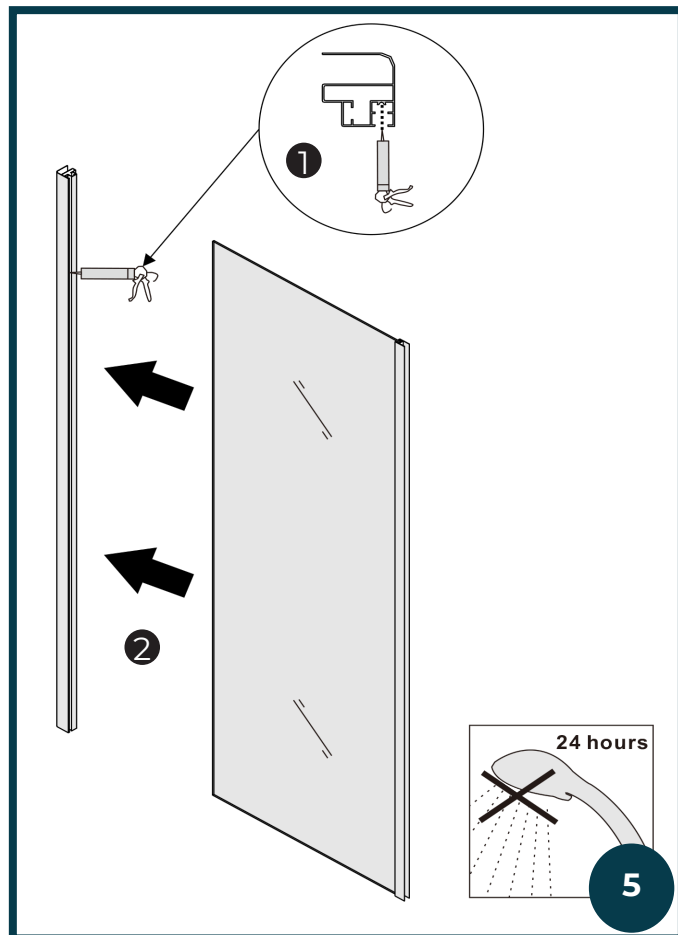

6° ÉTAPE

1. Installez les joints qui bloquent le verre entre le profilé angulaire en aluminium et le verre. Insérer le joint de bas en haut.
2. Le joint en question est enroulé dans un paquet et doit être inséré à pression entre le verre et le châssis.

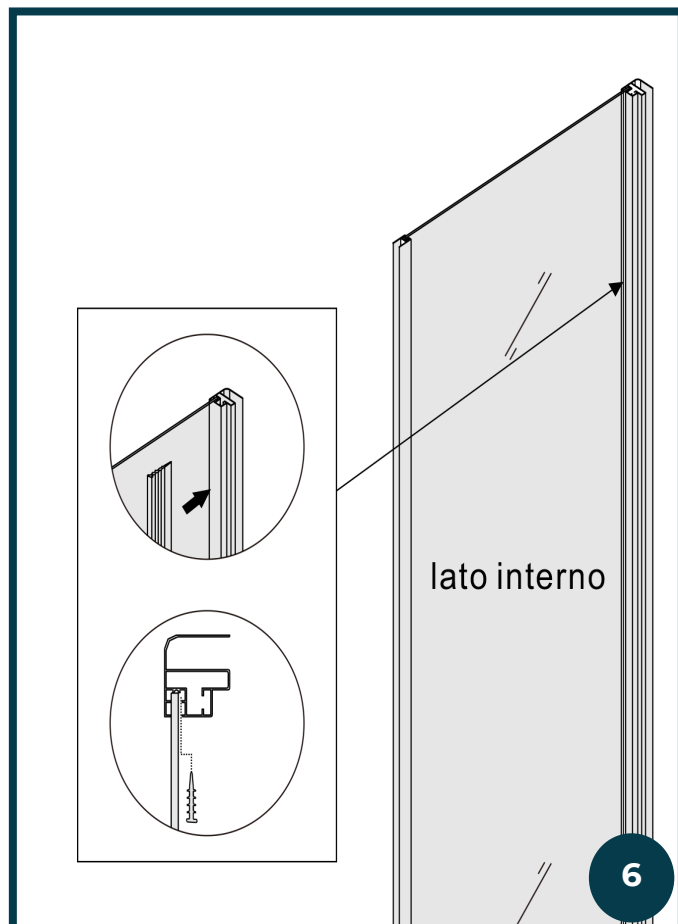

7° ÉTAPE

1. Insérez la paroi fixe entre le profilé mural et le profilé en aluminium de la porte antérieure.

IMPORTANTE:

Pour une installation optimale nous recommandons de supprimer le profilé mural de la paroi et d'insérer-t-il sur la paroi fixe en verre. Après, appuyez les composants assemblé sur le receveur et fixez le profilé mural suivante.

NOTEZ BIEN:

Aucun composant doit être installé sous la paroi fixe laterale. Elle doit être appuyé sur le receveur. Après, mettez du silicone par l'extérieure.

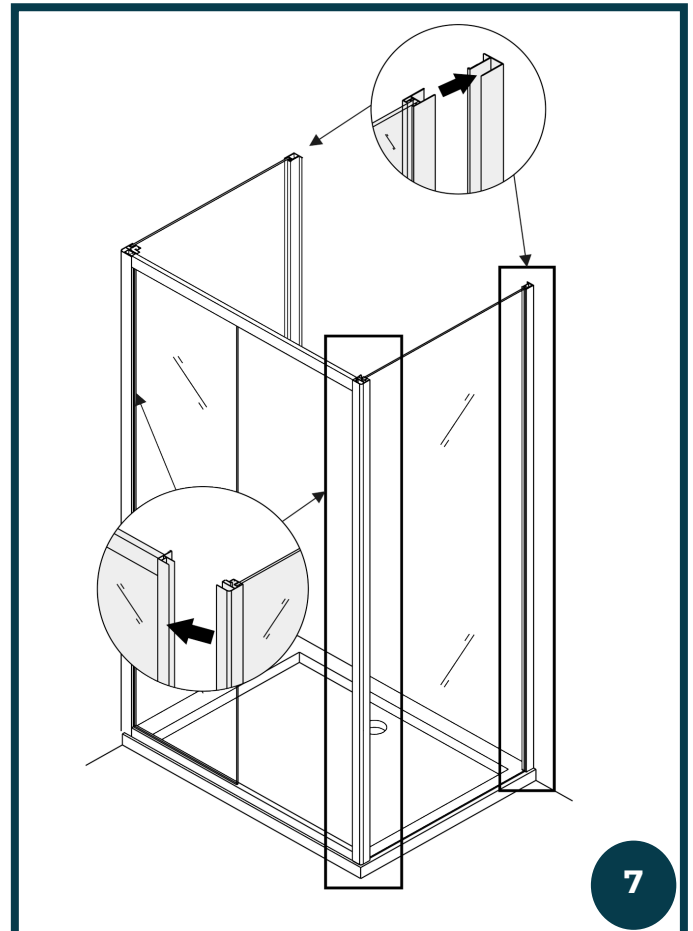

8° ÉTAPE

1. Installez les roulettes de coulissement inférieurs (avec bouton de largage) et supérieurs.

Notez : Les **roulettes supérieurs** sont réglables. Si, après le montage de la porte, le coulissement n'est pas fluide, les roulette peuvent être réglé à travers de la vis inférieur sur le roulement.

Les roulettes de coulissement inférieurs sont détachables pour favoriser le nettoyage et la l'entretien ordinaire.

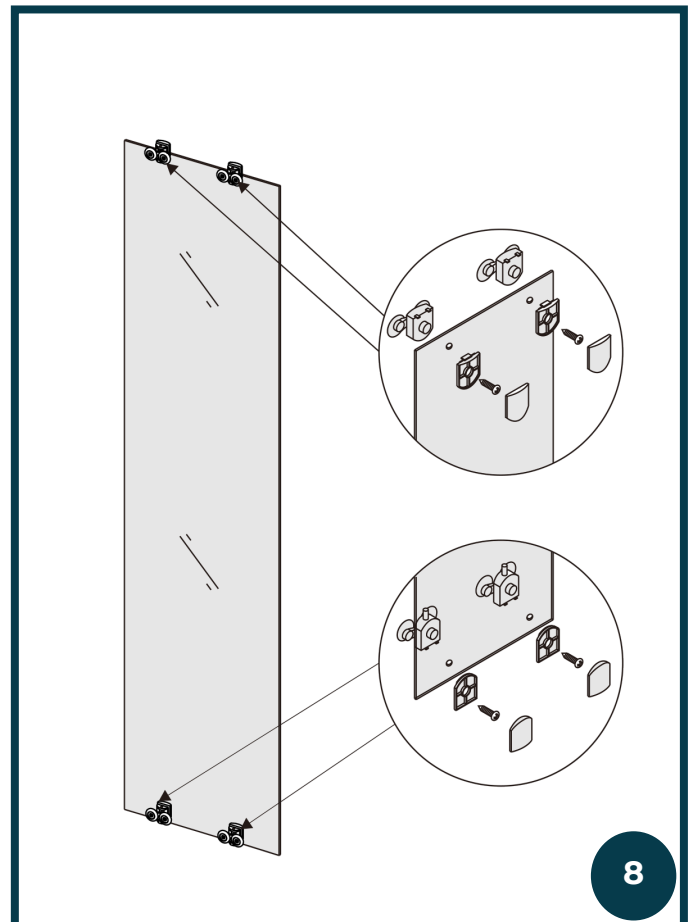

9° ÉTAPE

1. Accrochez les verres au rail de coulissement. . Assurez-vous que la porte soit sur axe, voyez l'étape précédent por régulier le roulements.

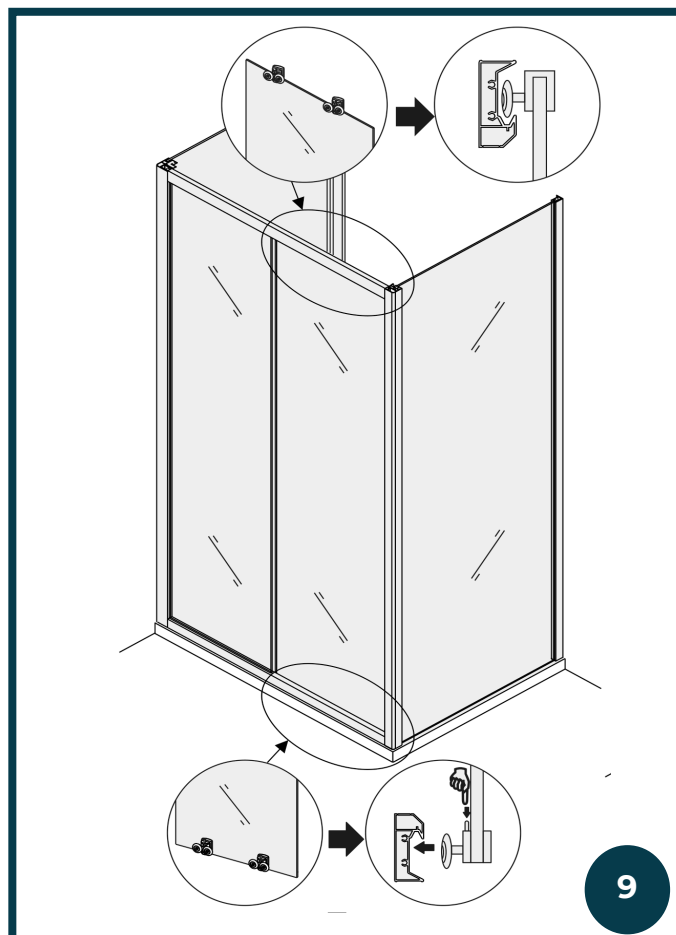

10° ÉTAPE

1. Installez le joint magnétique d'arrêt sur le verre .
2. Vérifiez la mise à plombe, faites le trous et appliquez la vis par la coté intérieur pour bloquer la paroi au profilé mural. Après cette étape, recouvrez avec le profilé de couverture (H. 190 cm qui cache le profilé mural et occulte le fixages).
3. Connectez le profilé en aluminium angulaire avec la porte frontale coulissante en utilisant les vis 4 x 20 (précédemment faire le trous avec le forage).

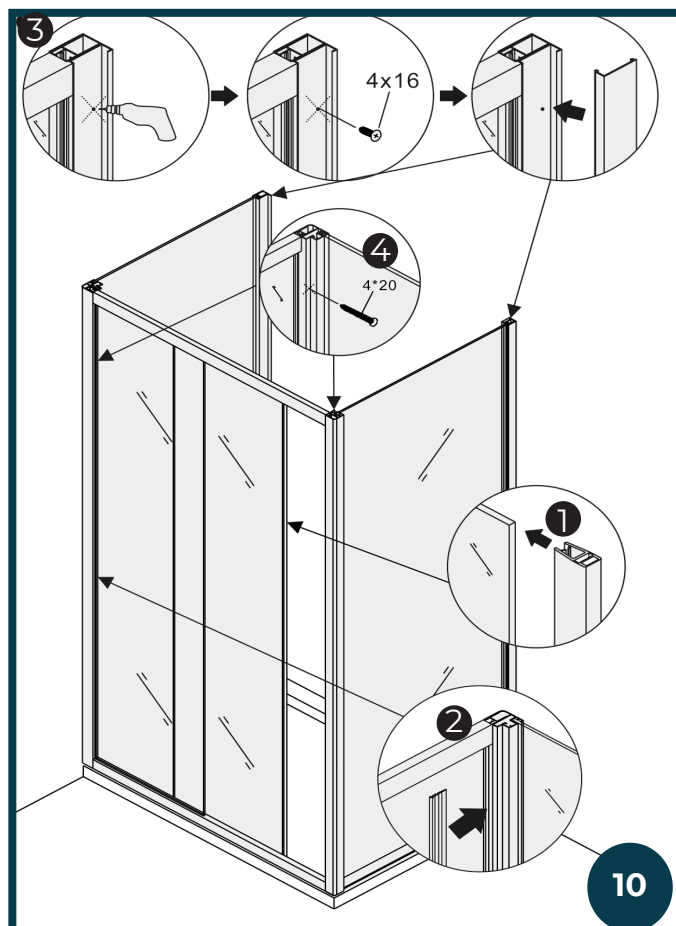

11° ÉTAPE

1. Installez le cutée sur le rail supérieur et inférieur. Utiliser les vis plus petits en dotations. Si seront utilisé les vis plus grandes, le rail se va demager sur la cotè frontale.
2. Installez le poignée.
3. Installez le joint d'étanchéité entre le mur fixe et la porte coulissante .

ATTENTION:

En dotation vous trouverez un joint plus petit et un plus grande. Cela plus petit, doit être installé sur le verre fixe, cela plus grande, sur le verre coulissante.

4. Installez les capuchons de couverture sur la parte superieur du profilé en aluminium et mettre le silicone sur la parte extérieur de la porte long du périmetre selon l'illustration.

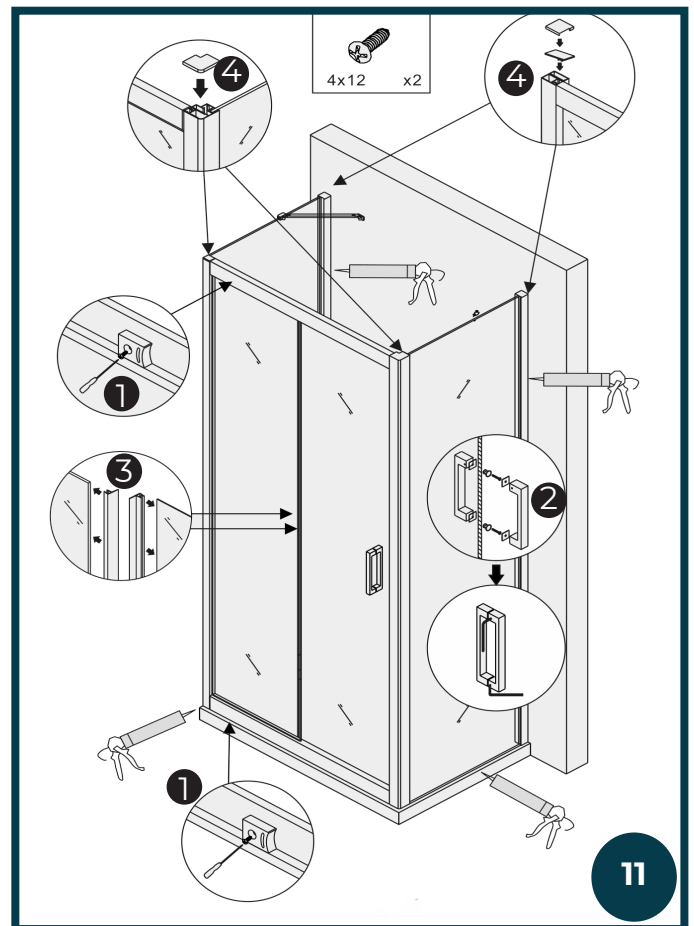

Seattle 3.0

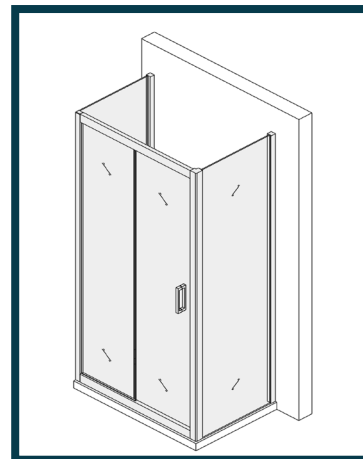
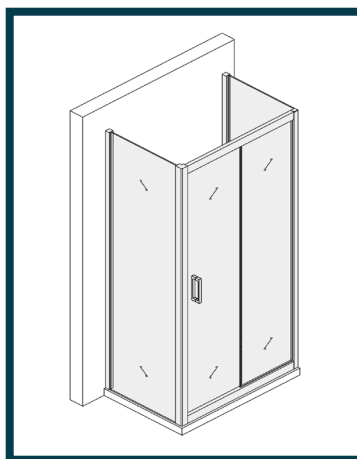

BESCHREIBUNG

Schiebeduschkabine mit 2 festen Seitenwänden H 190 aus 6 mm Glas.
Einbau der umkehrbaren Tür. Möglichkeit der Schnellentriegelung der unteren Schieberollen.
Manuelle Anpassung der Wandelemente von 2,5 cm pro Seite.
Gestell aus verchromtem Aluminium, Glas mit Anti-Kalk-Behandlung, gekennzeichnet durch spezielle grüne Etiketten.

TECHNISCHE BESCHREIBUNG

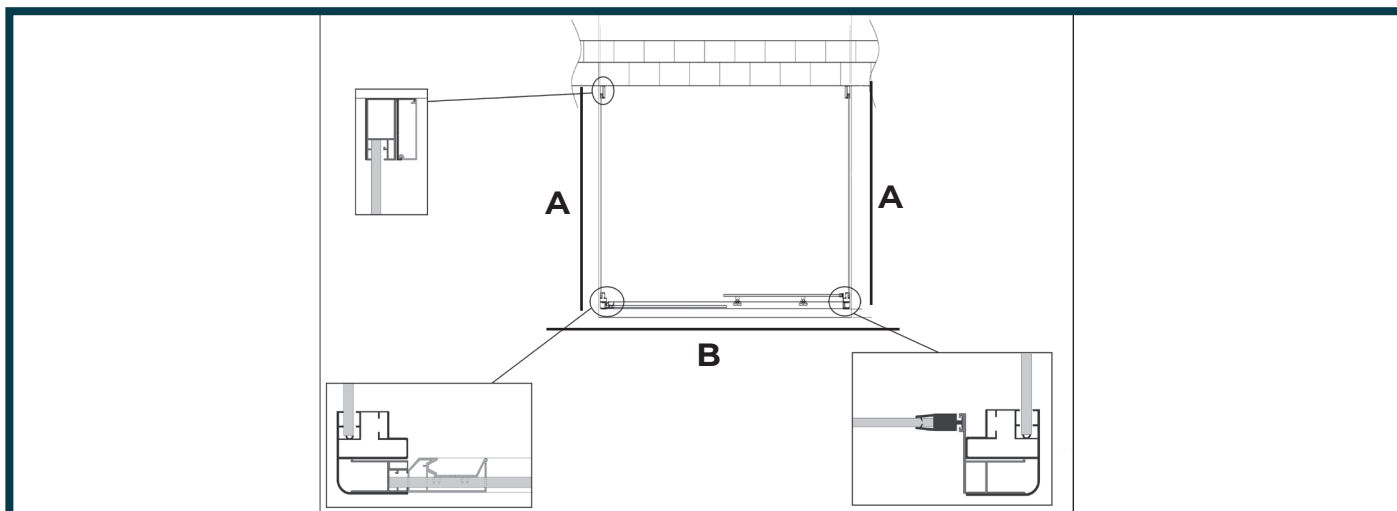

DETAILS ZUBEHÖR

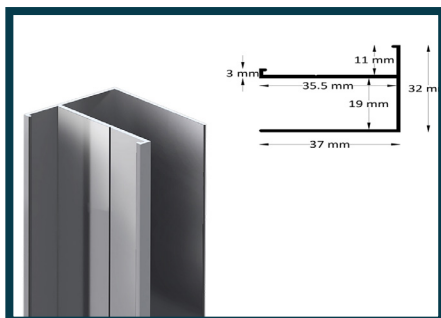

Festes Wandelement

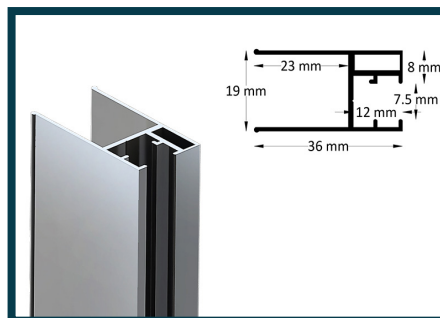

Festes Glaselement

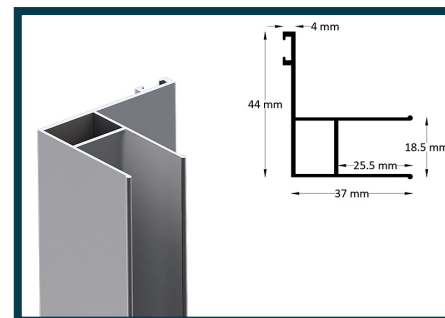

Gleitmagnetelement

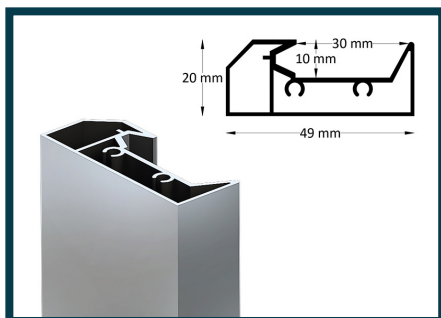

Radschienelement

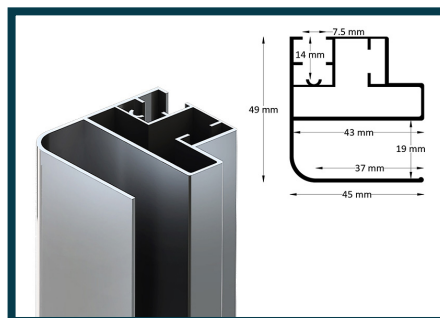

Eckelement

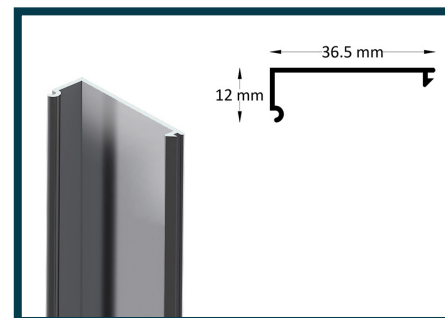

Abdeckelement

Laneri®

sanitary ware

c/da Gentilomo snc
94100 Enna Italy
www.laneribagni.it

Seattle 3.0



TABELLE ZUR EINSTELLUNG SEITE A

FESTE WAND	EINSTELLUNG A	
	MIN.	MAX.
650	625	650
675	650	675
700	675	700
750	725	750
800	775	800
900	875	900

TABELLE ZUR EINSTELLUNG SEITE B

SCHIEBETÜR	EINSTELLUNG B	
	MIN.	MAX.
1000 (Quermaße 87 cm)	950	1000
1100 (Quermaße 97 cm)	1050	1100
1200 (Quermaße 107 cm)	1150	1200
1300 (Quermaße 117 cm)	1250	1300
1400 (Quermaße 127 cm)	1350	1400
1500 (Quermaße 137 cm)	1450	1500
1600 (Quermaße 147 cm)	1550	1600
1700 (Quermaße 157 cm)	1650	1700

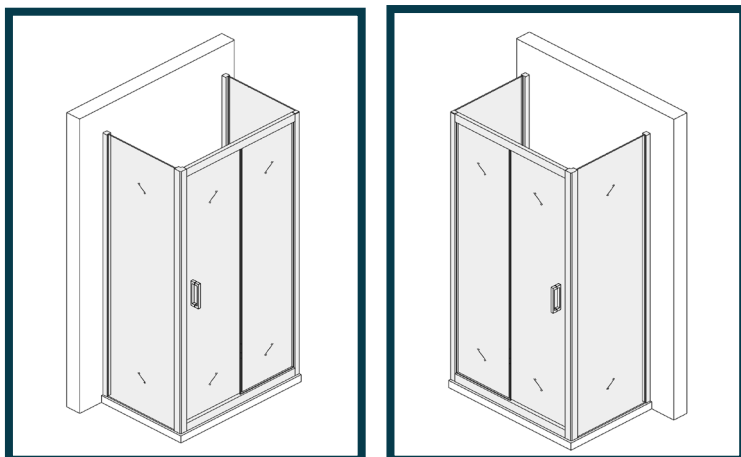
SEATTLE 3.0

BENÖTIGTE WERKZEUGE



Bleistift

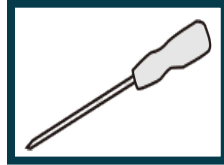

Schraubendreher

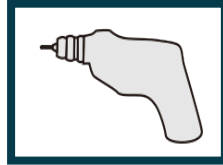

Bohrer



Maßband

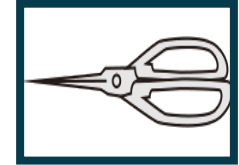

Schere

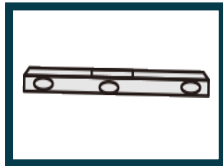

Wasserwaage



Sechskantschlüssel
(mitgeliefert)

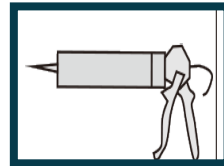

Silikon

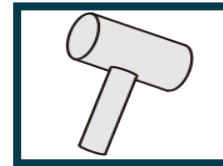

Gummihammer

PAKETINHALT

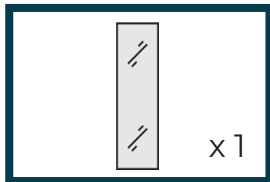

Festes Glas

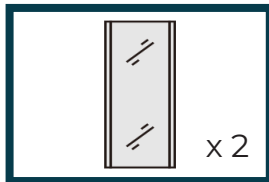

Feste Glaswand
H 1,90

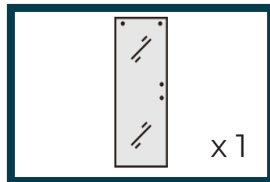

Schiebeglas

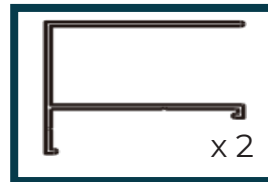

Wandelement
H 1,90

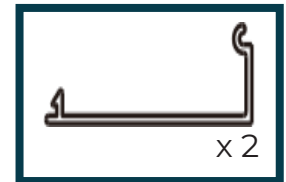

Wandelementab-
deckung H 1,90

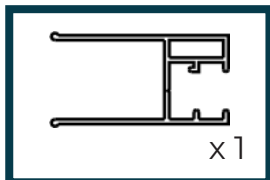

Festes Glaselement

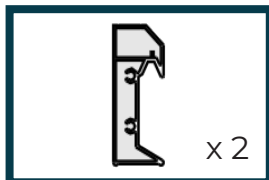

Gleitschiene

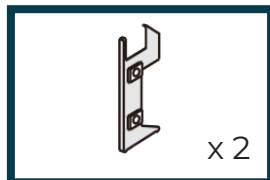

Fester Seitenver-
binder mit Schlitz

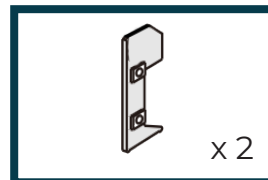

Verschiebbarer Seiten-
verbinder ohne Schlitz

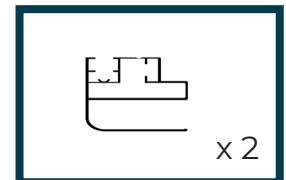

Winkелеlement
H 1,90



Abnehmbare untere
Räder



Obere Räder

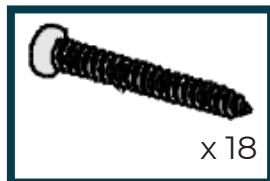

Schrauben 4 x 30

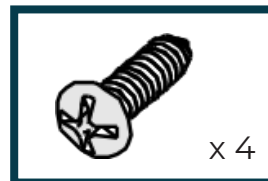

Schrauben 4 x 16

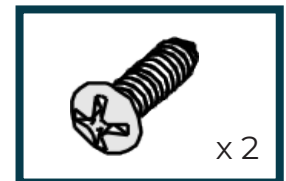

Schrauben 4 x 12

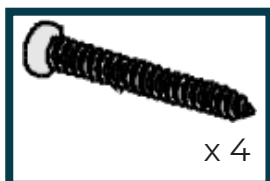

Schrauben 4 x 20

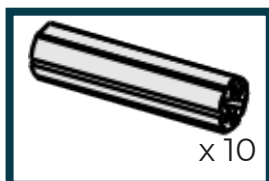

Dübel

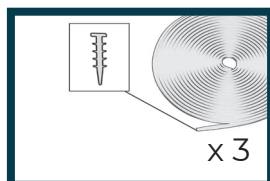

Rollendichtung mit
Glasstopp

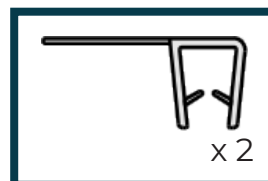

Spritzschutz-
dichtung

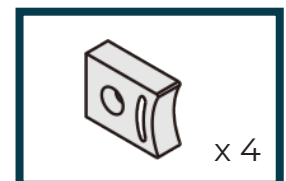

Enddichtung

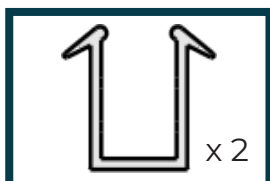

Glasschutz-
dichtung

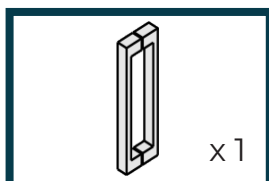

Griffe

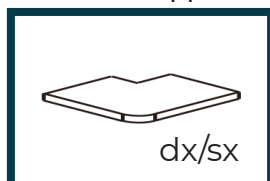

Eckelementab-
deckung



Abdeckung



Magnetdichtung

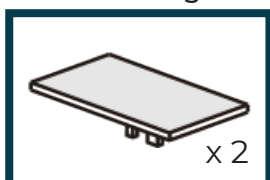

Obere Abdeckung mit
festem Glasanschlag

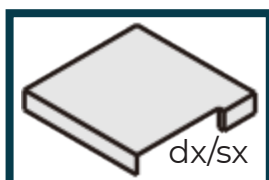

Obere Wandele-
mentabdeckung

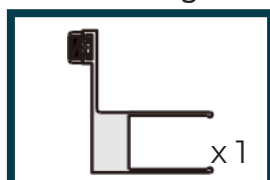

Magnetelement H
1,90

MONTAGE

1. SCHRITT

1. Stellen Sie mit Hilfe der Wasserwaage sicher, dass die Duschwanne eben ist.
2. Platzieren Sie das Element an der Wand und verwenden Sie die Wasserwaage zum senkrechten Stellen.
3. Markieren Sie die Löcher mit dem Bleistift auf der Wand.
4. Bohren Sie mit dem Bohrer die Löcher in die Wand.
5. Setzen Sie den Dübel ein und schrauben Sie die Schrauben fest, um das Element zu befestigen.

WICHTIG

Es wird empfohlen, die Elemente nicht direkt an der Außenkante der Duschwanne anzubringen, immer etwa 1 cm Abstand lassen für ein optimales ästhetisches Ergebnis

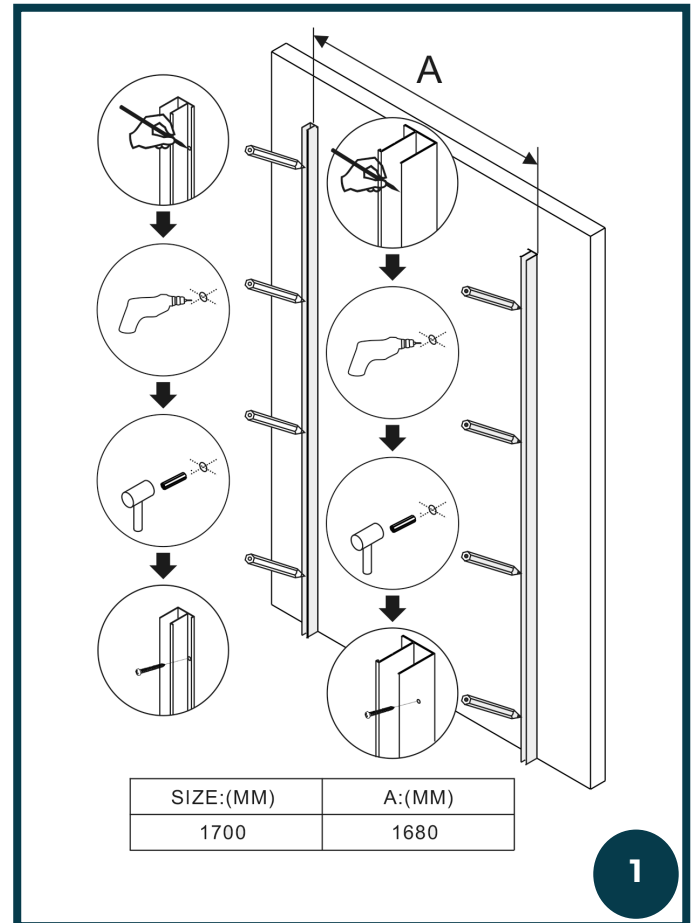

1

2. SCHRITT

1. Verwenden Sie eine 4x30 Schraube, um die untere Aluminiumschiene mit dem vertikalen Element zu verbinden. Auf diese Weise bauen wir den Türrahmen (Gerüst).

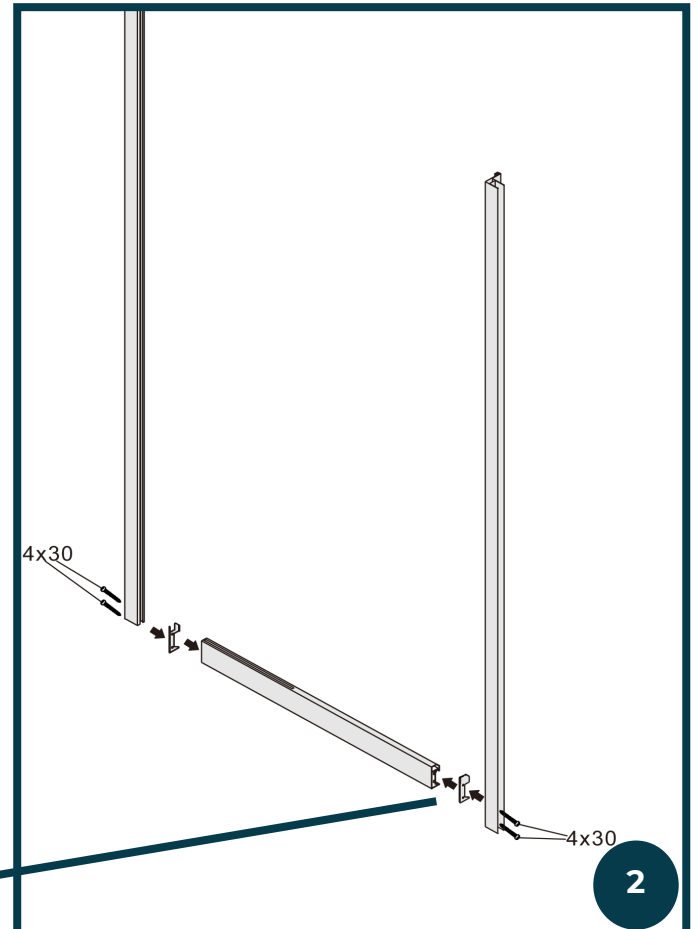
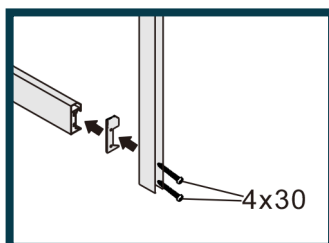

2

3. SCHRITT

1. Legen Sie die Kunststoffteile wie in Abbildung A in die Aluminiumschiene ein. (Abdeckung)
2. Setzen Sie die Dichtung in das untere Element ein. Wie in Abbildung A. (Glasschutzdichtung)
3. Setzen Sie das feststehende Glas wie in Abbildung B ein.

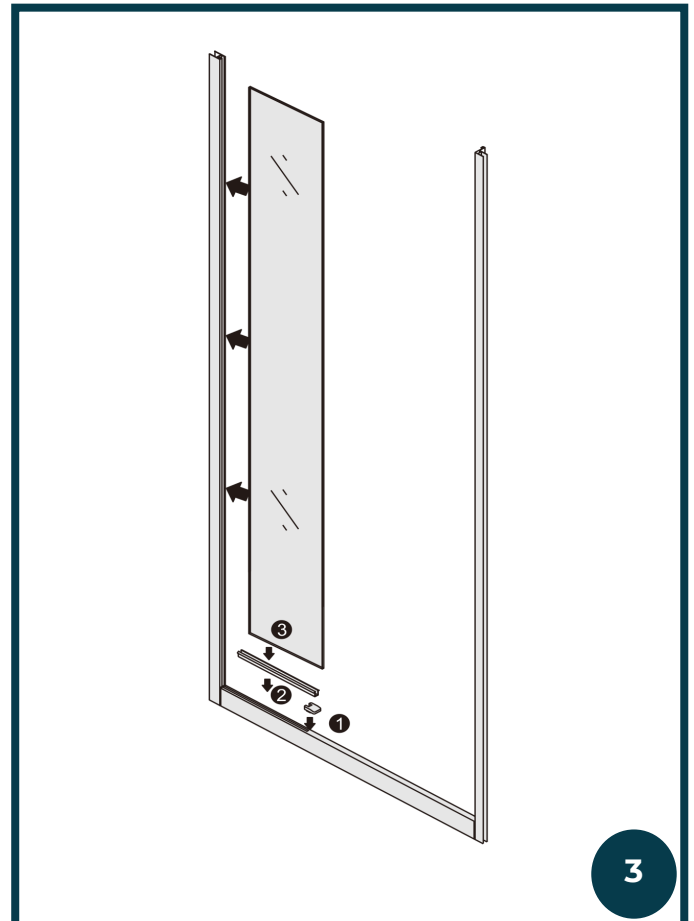
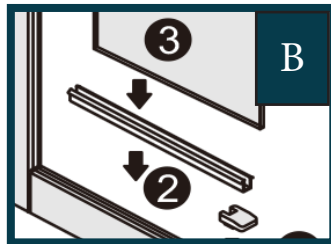
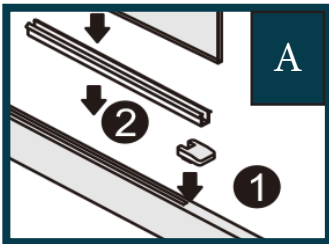

4. SCHRITT

1. Wiederholen Sie den vorhergehenden Schritt (2 und 3) für den oberen Teil des Rahmens

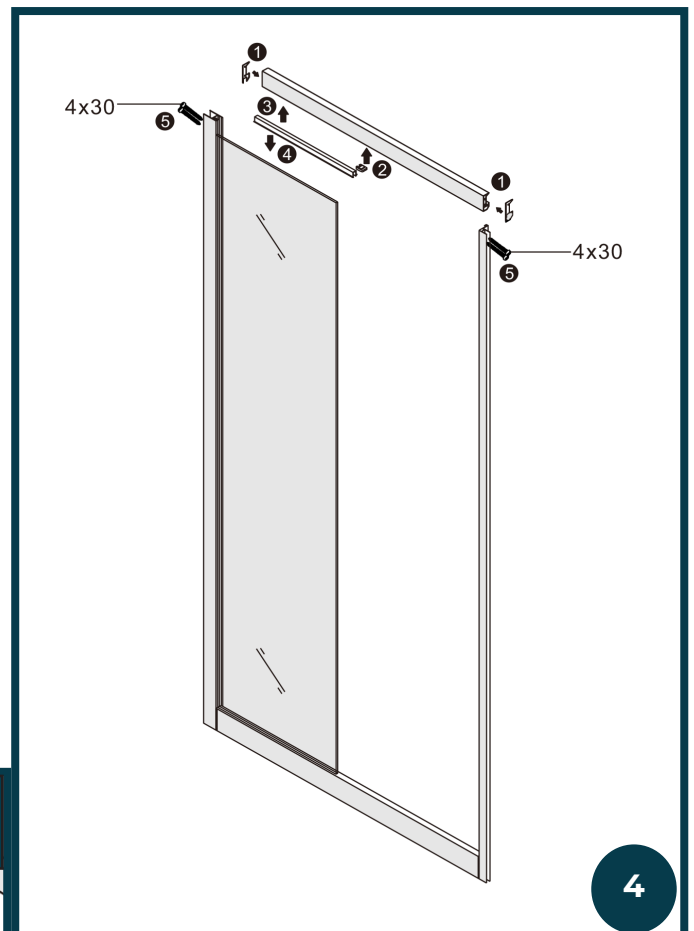
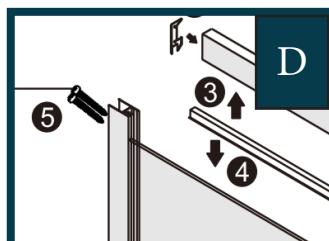
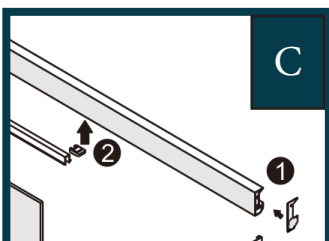

5. SCHRITT

1. Tragen Sie das Silikon in die Einbuchtung der Ekelemente auf.
2. Setzen Sie die feststehenden Glaswände in das Innere der Ekelemente ein und führen Sie während es noch frisch ist, den nächsten Schritt (6) aus.

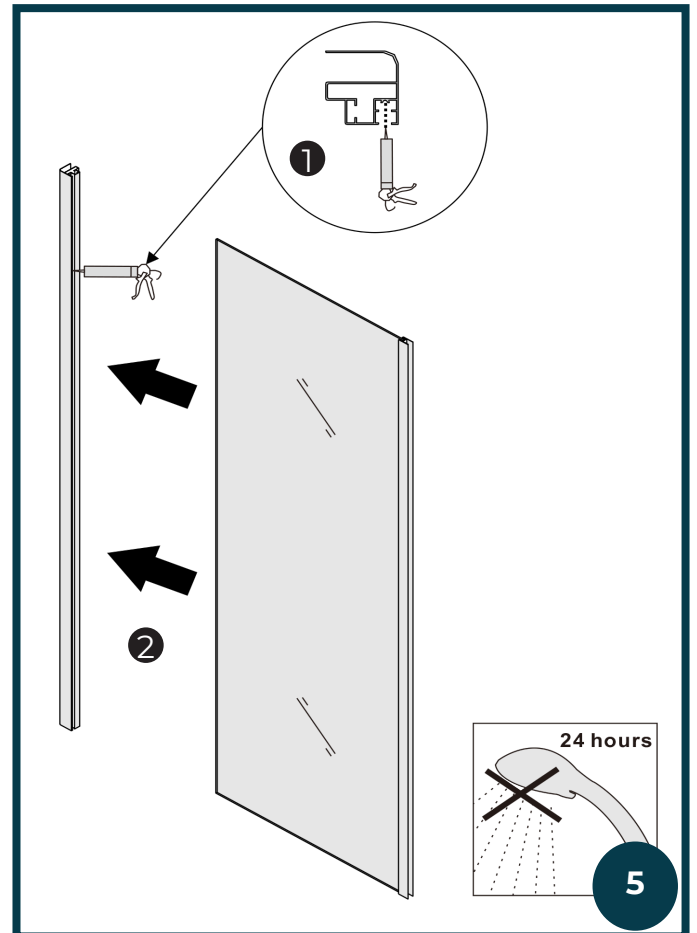

6. SCHRITT

1. Montieren Sie die Glasanschlagdichtungen schräg zwischen Glas und Aluminiumelement und achten Sie darauf, dass sie von unten nach oben eingesetzt werden.
2. Die zu verwendenden Dichtungen sind diejenigen, die in den Beuteln aufgerollt sind, sie müssen durch Druck zwischen Glas und Rahmen eingeführt werden.
- 3.

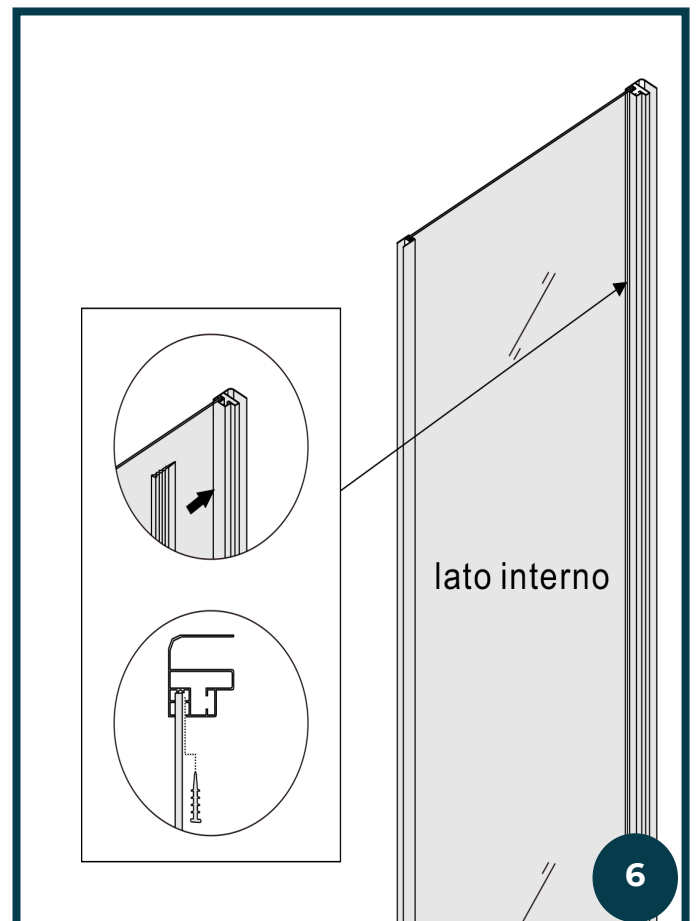

7. SCHRITT

1. Setzen Sie die festen Wände zwischen die Wandelemente und das Aluminiumelement der vorderen Tür ein.

WICHTIG :

Für einen korrekten Einbau empfehlen wir das Wandelement von der Wand zu entfernen, es auf die feste Glaswand einzufügen, um es dann auf die Gesamtplatte zu legen, und das Wandelement im nächsten Schritt zu fixieren.

BITTE BEACHTEN SIE:

nichts geht unter die feste Platte, sie wird gelegt und außen wird Silikon aufgetragen.

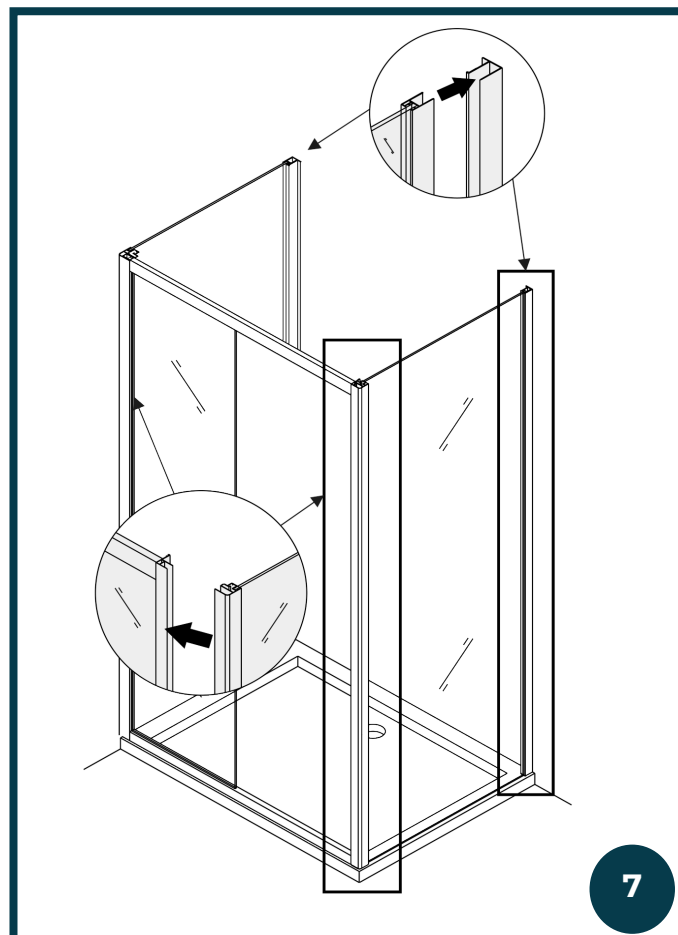

7

8. SCHRITT

1. Montieren Sie die unteren (mit Schnellverschlussdruckknopf) und die oberen Rädchen.

Hinweis : Die **oberen Räder** sind verstellbar. Wenn die Türen nach der Montage der Duschkabine nicht leichtgängig sind, können sie mit der unteren Schraube am oberen Lager eingestellt werden.

Die unteren Gleiträder sind abnehmbar, um routinemäßige Reinigungs- und Wartungsarbeiten zu erleichtern.

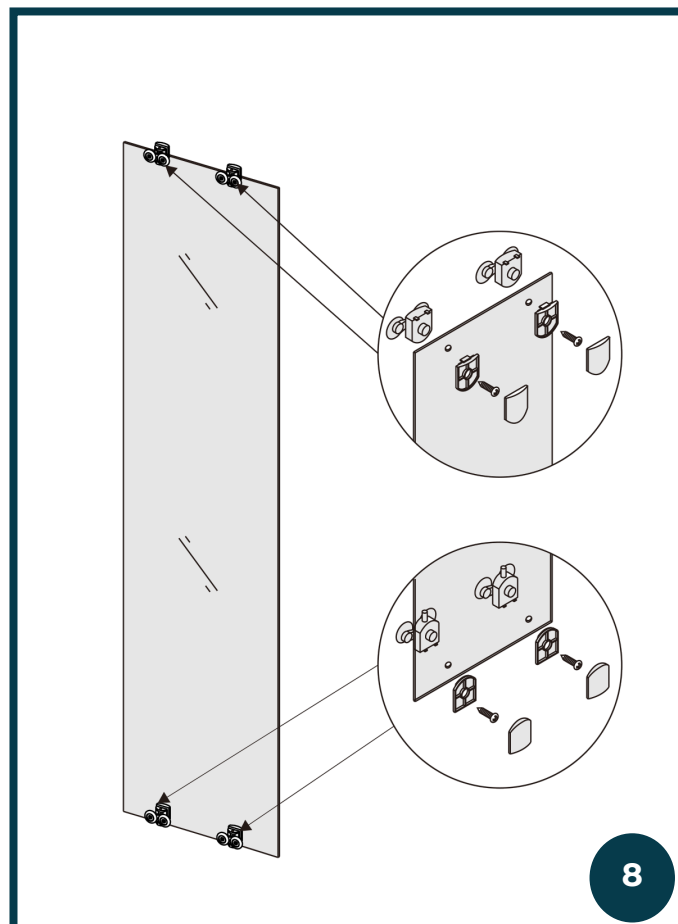

8

9. SCHRITT

1. Hängen Sie die Türen in die Gleitschiene ein. Stellen Sie sicher, dass die Tür ausgerichtet ist, siehe vorherigen Schritt, um sie anzupassen.

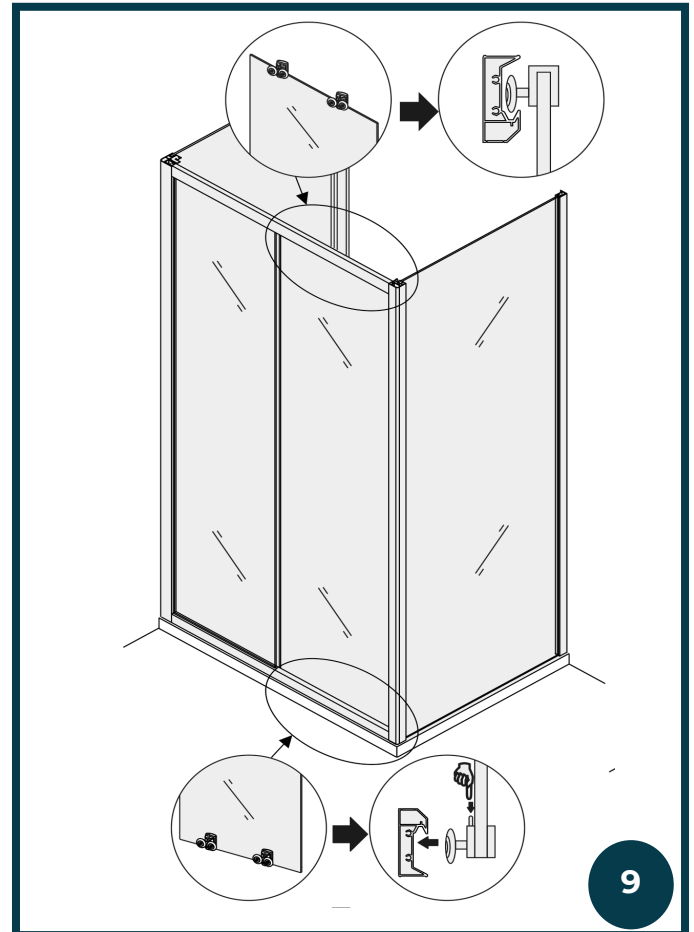

10. SCHRITT

1. Installieren Sie die magnetische Verschlussdichtung an der Tür.
2. Korrigieren und loten Sie die Wände aus, bohren anschließend Löcher und bringen die Schrauben von innen an, um die Box an den Wandelementen zu befestigen, dann decken Sie die beiden Wandelemente mit dem dekorativen Aluminiumelement ab, um die Befestigungen zu verbergen.
3. Verbinden Sie mit 4 x 20 Schrauben die Aluminiumelemente rechtwinklig mit der Frontschiebetür (bohren Sie zuerst das Loch mit Hilfe des Bohrers).

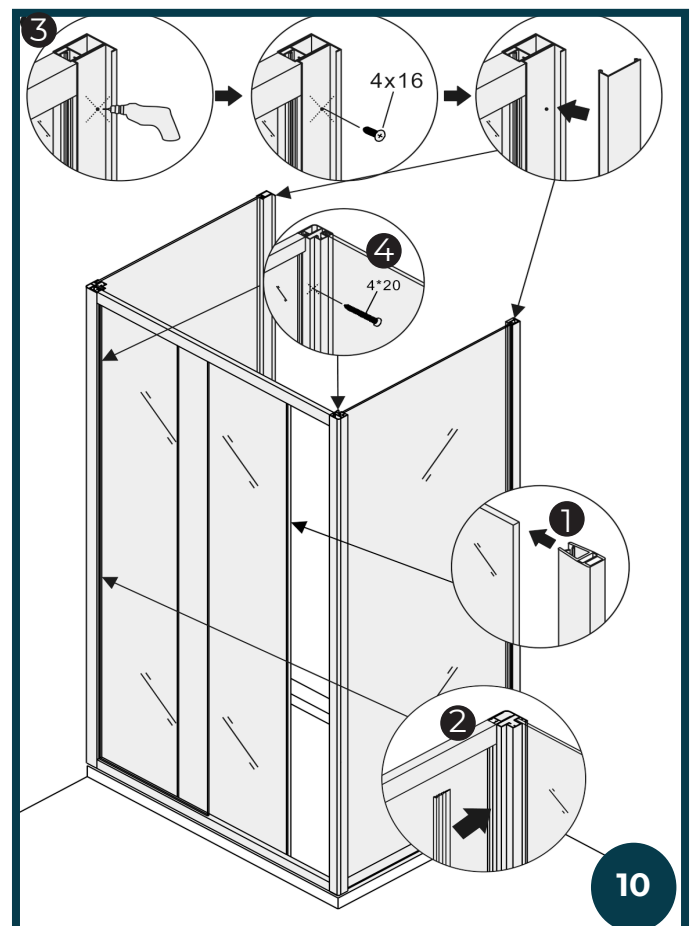

11. SCHRITT

1. Montieren Sie das Endelement oben und unten an der Schiene. Verwenden Sie die mitgelieferten kleineren Schrauben, sonst besteht die Gefahr, dass die Sichtseite der Laufschiene durchstochen wird.
2. Montieren Sie den Griff.
3. Installieren Sie die Dichtungen zwischen dem festen Glas und der Schiebetür.

BITTE BEACHTEN SIE

Enthalten ist eine höhere Dichtung und eine untere, die untere wird auf dem festen Glas montiert die höhere auf dem Schiebeglas.

4. Montieren Sie die Abdeckkappen im oberen Teil des Aluminiumelementes und tragen Sie das Silikon auf den äußeren Teil der Duschkabine auf, entlang des gesamten Umfangs, wie in der Abbildung zu sehen.

