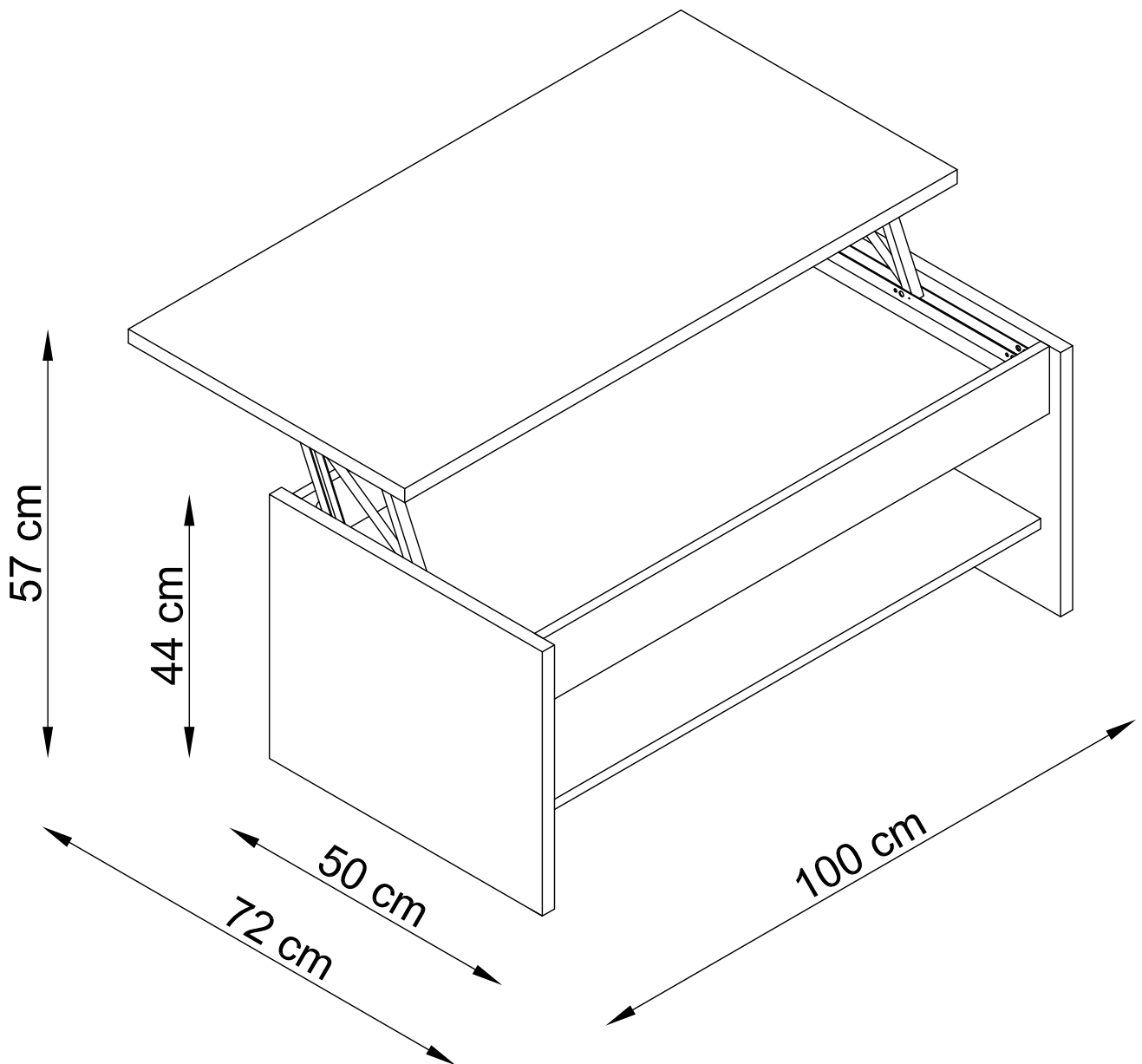
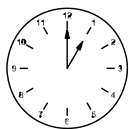

TABLE RELEVABLE

Ref.T38083

R.2





60 min.

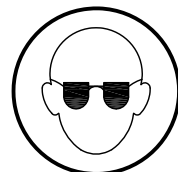
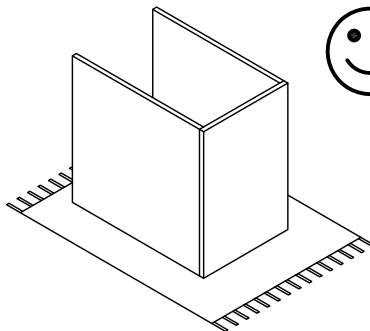
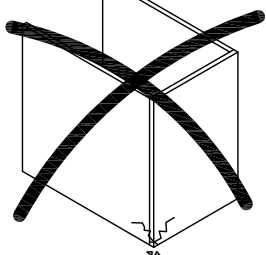
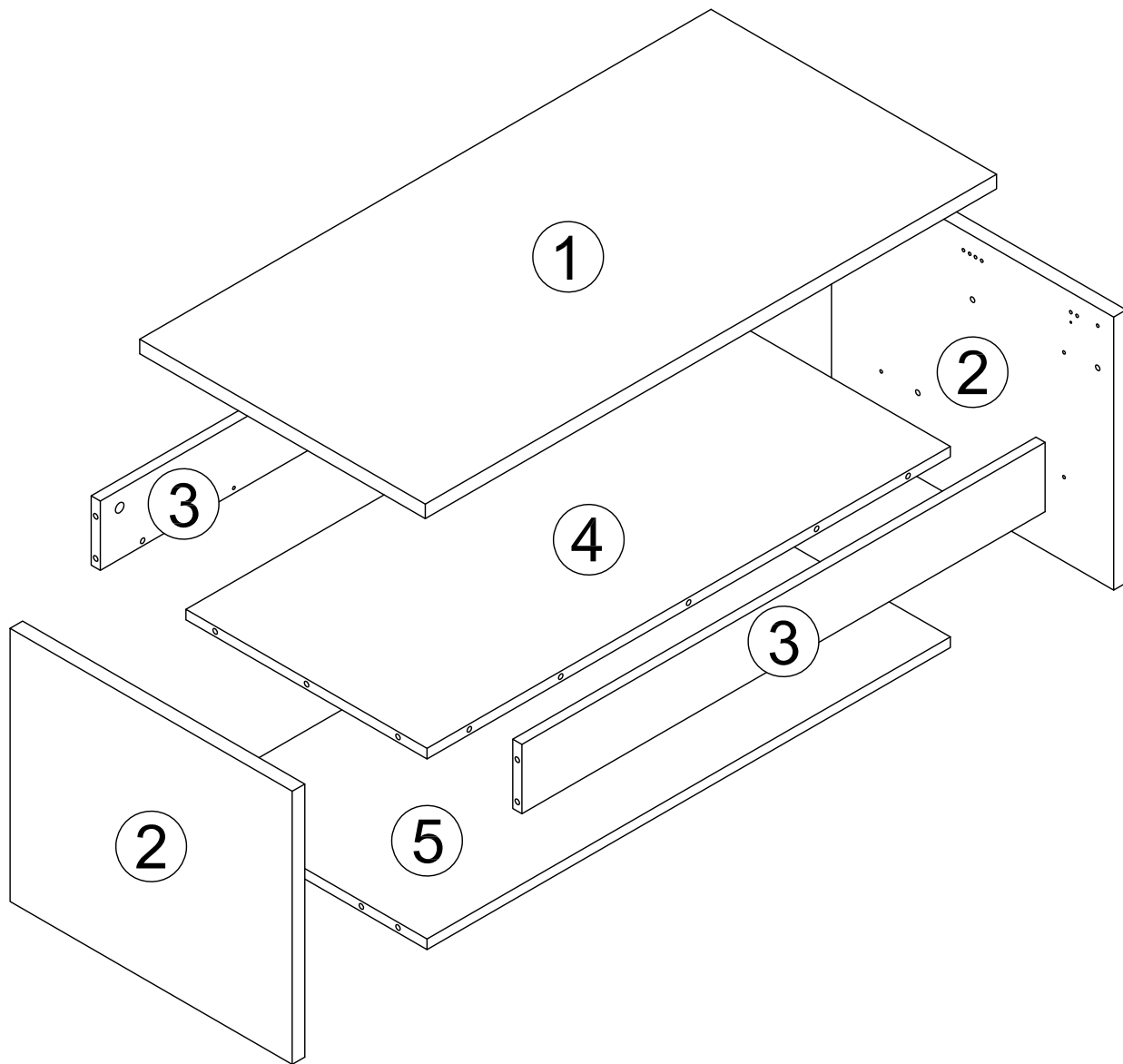
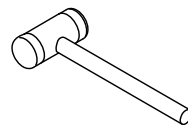
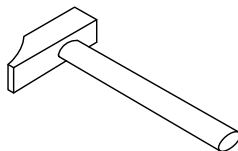
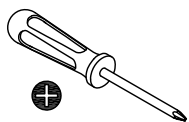

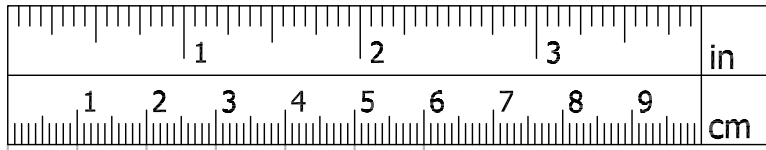

A x16

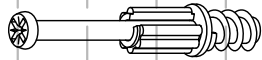

B x16



Ta x14



C x16

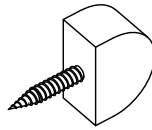

D x4

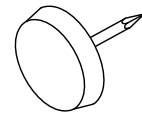

E x4

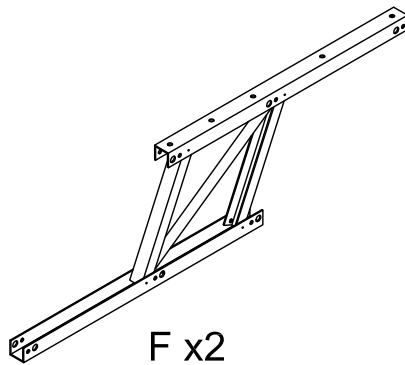

F x2



G x16

1

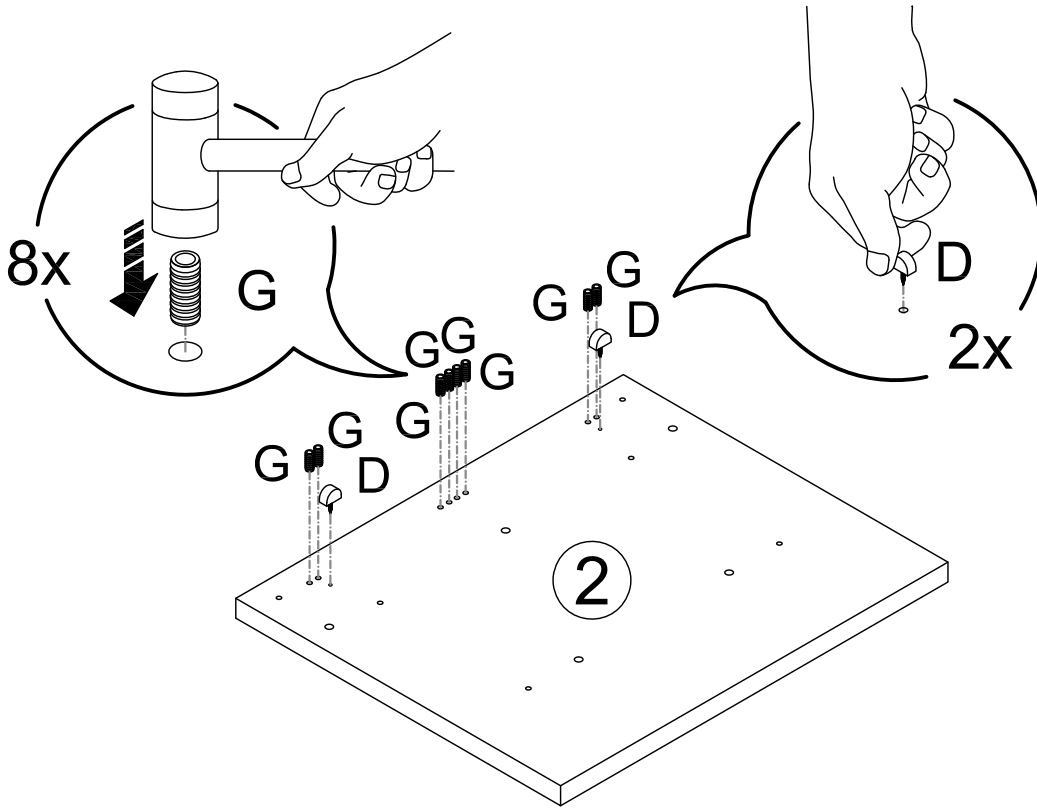
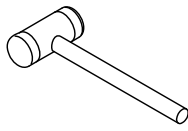

2x

2

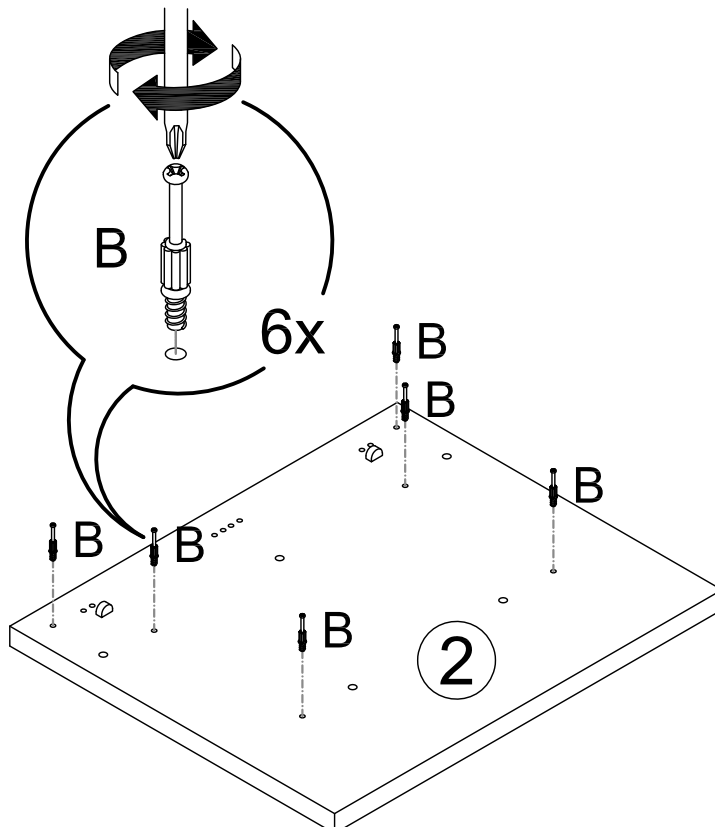
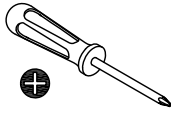

2x

3

A x4

C x4

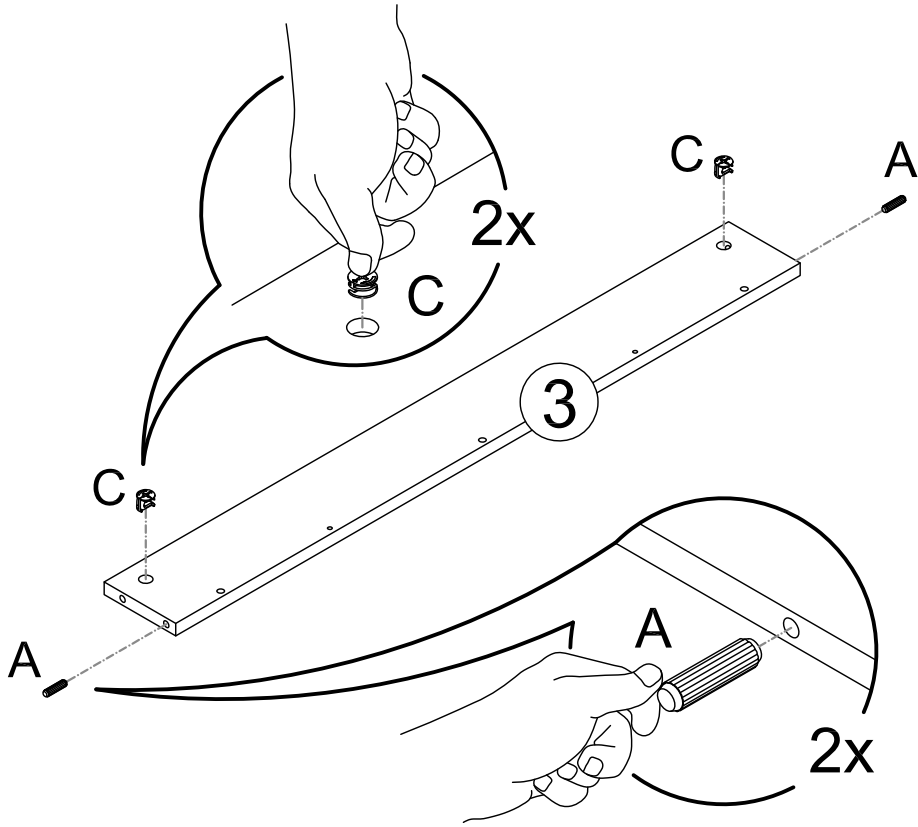
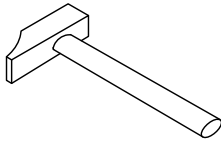

2x

4

B x4

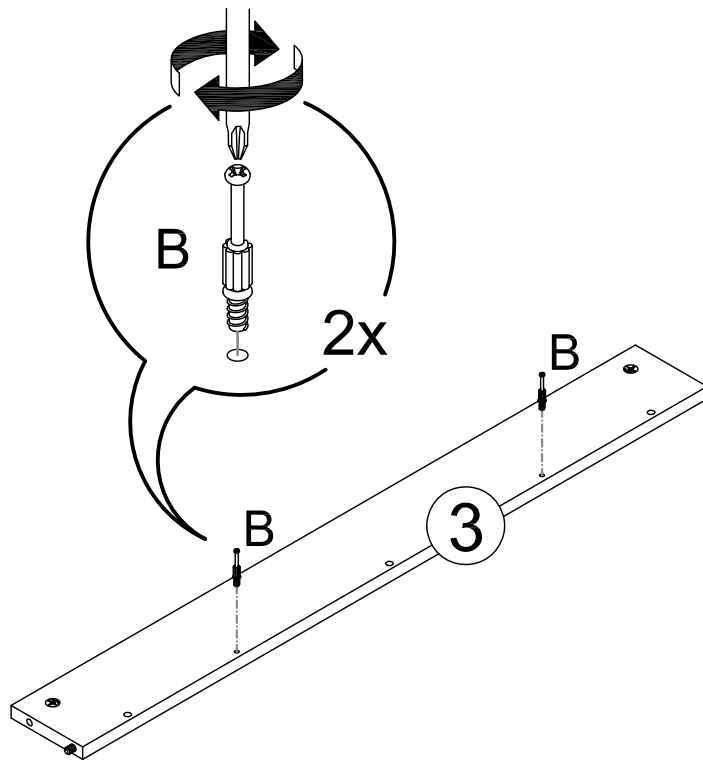
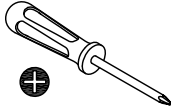

2x

5

A x8

C x8

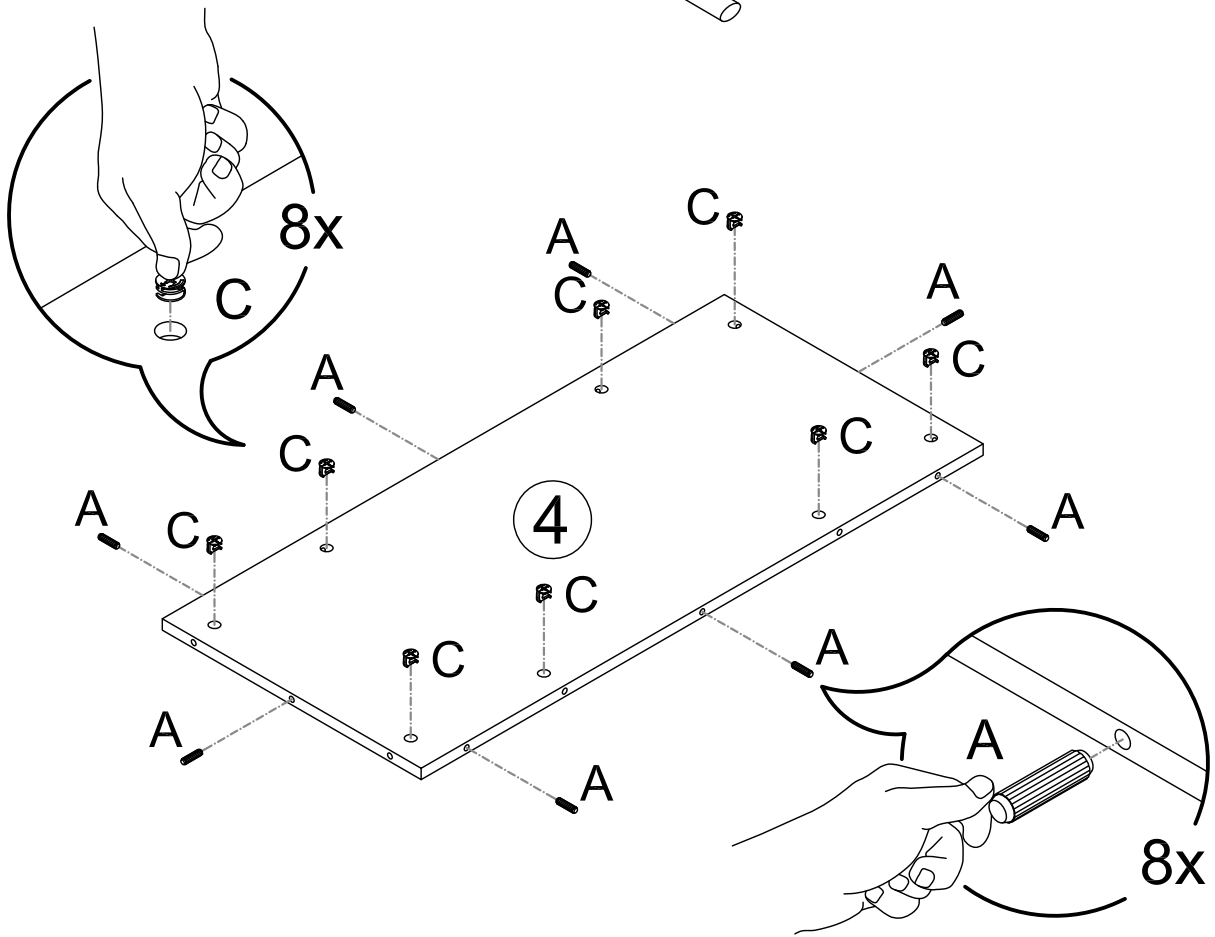
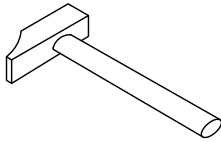

6

A x4

C x4

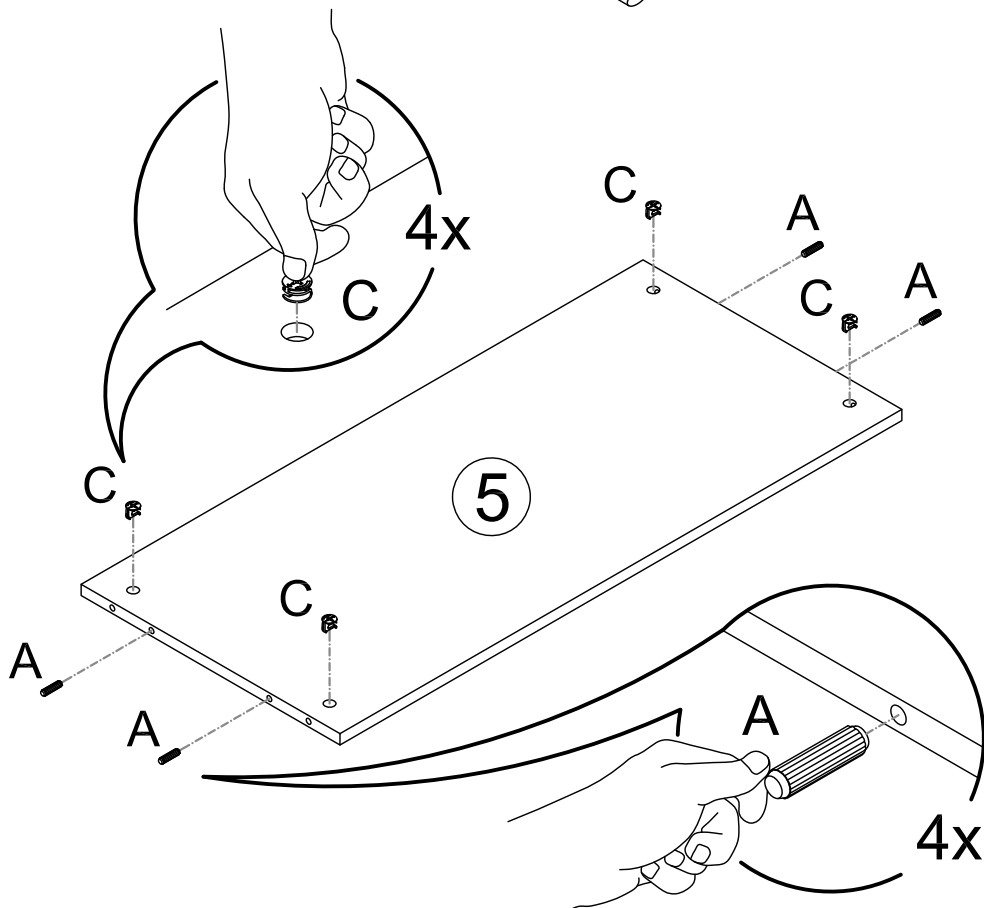
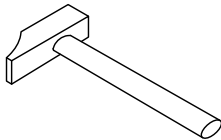

7

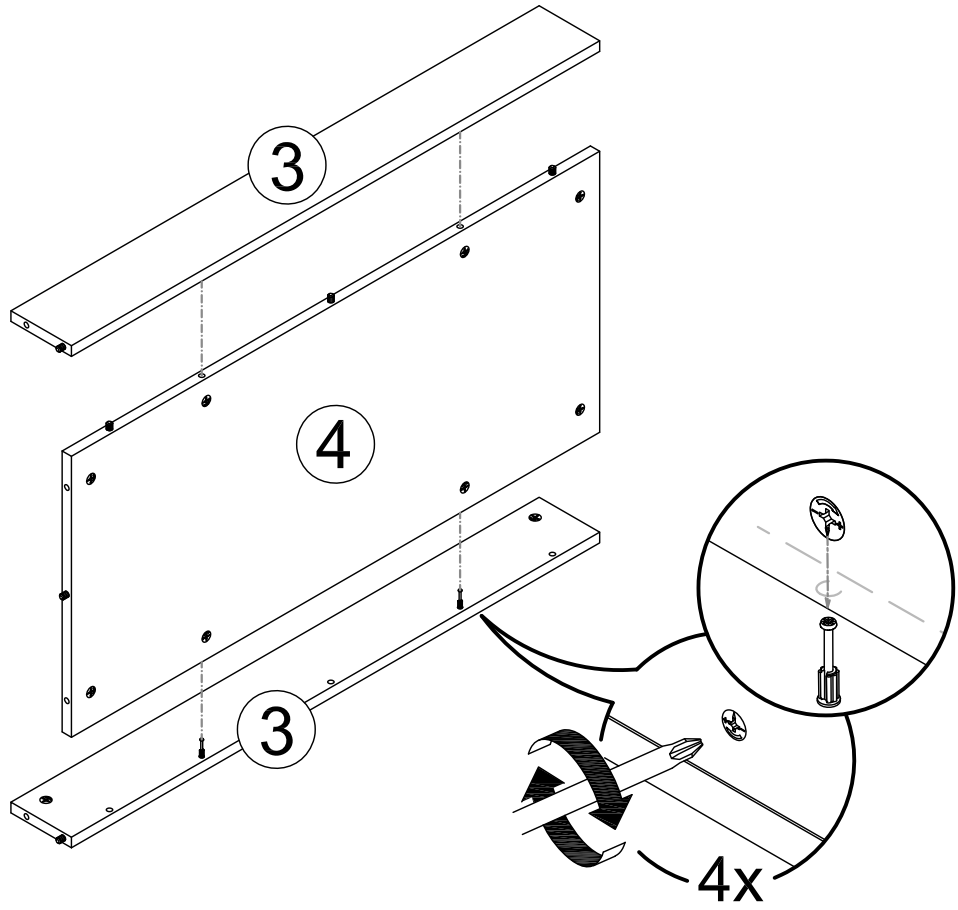
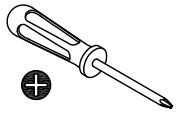

8

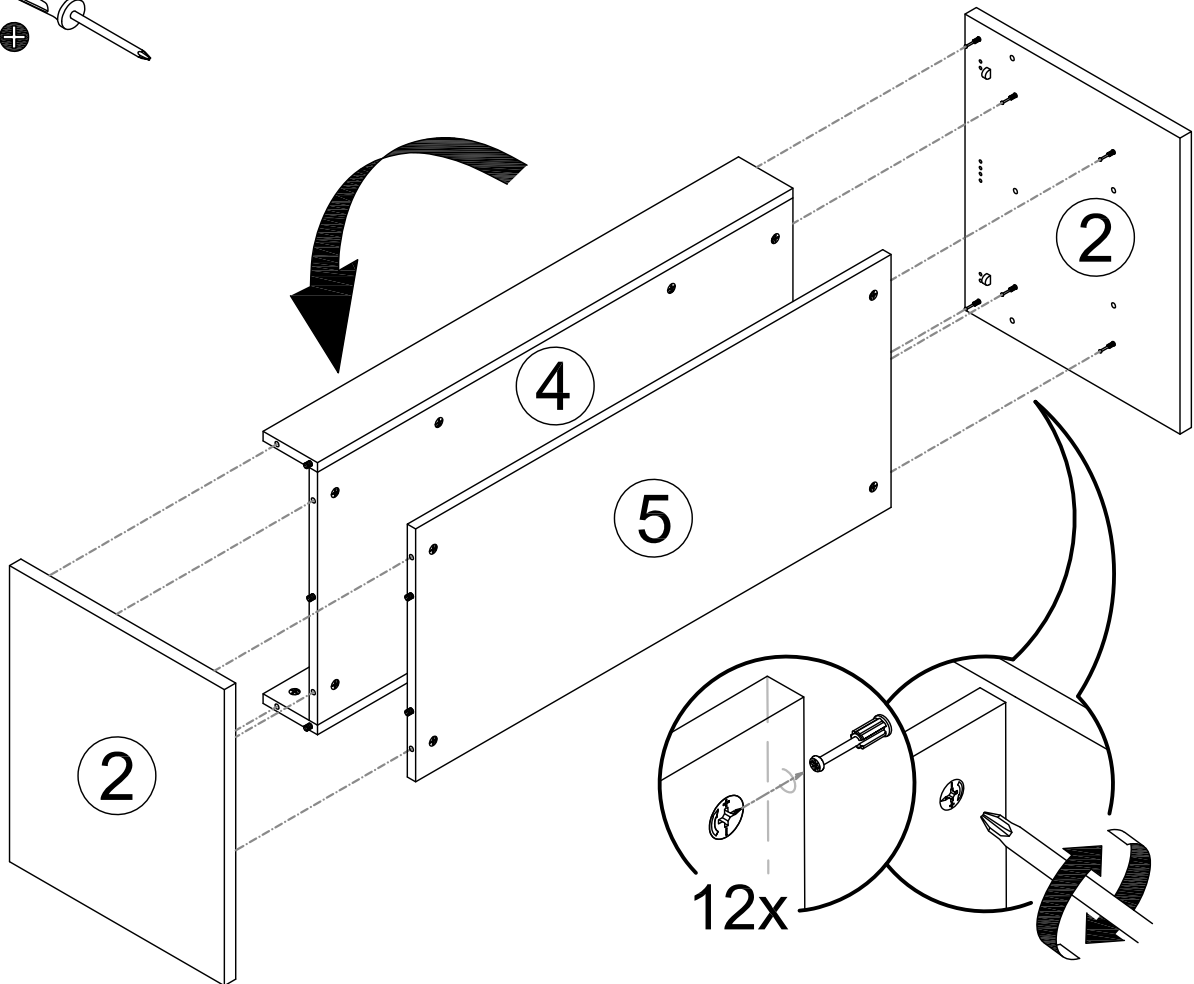
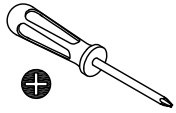

9

E x4

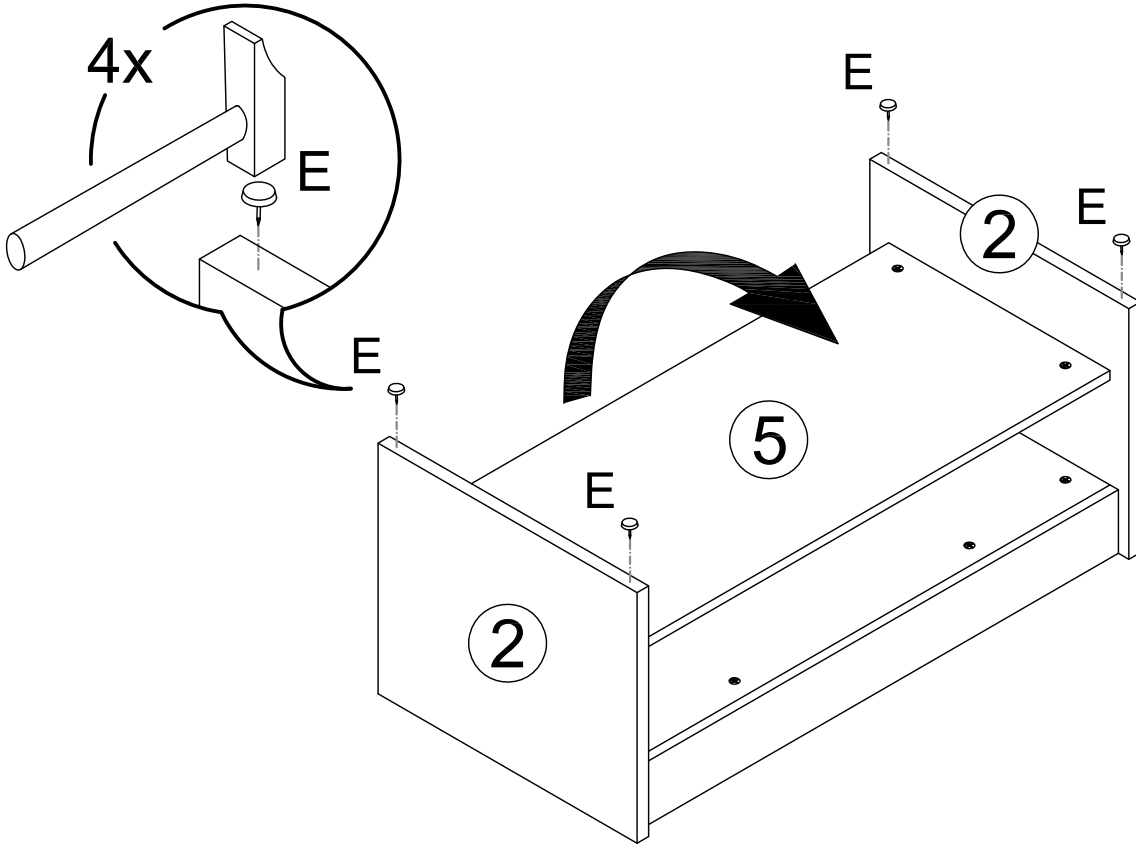
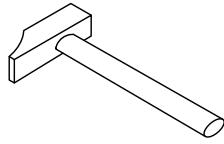

10

F x2

Ta x8

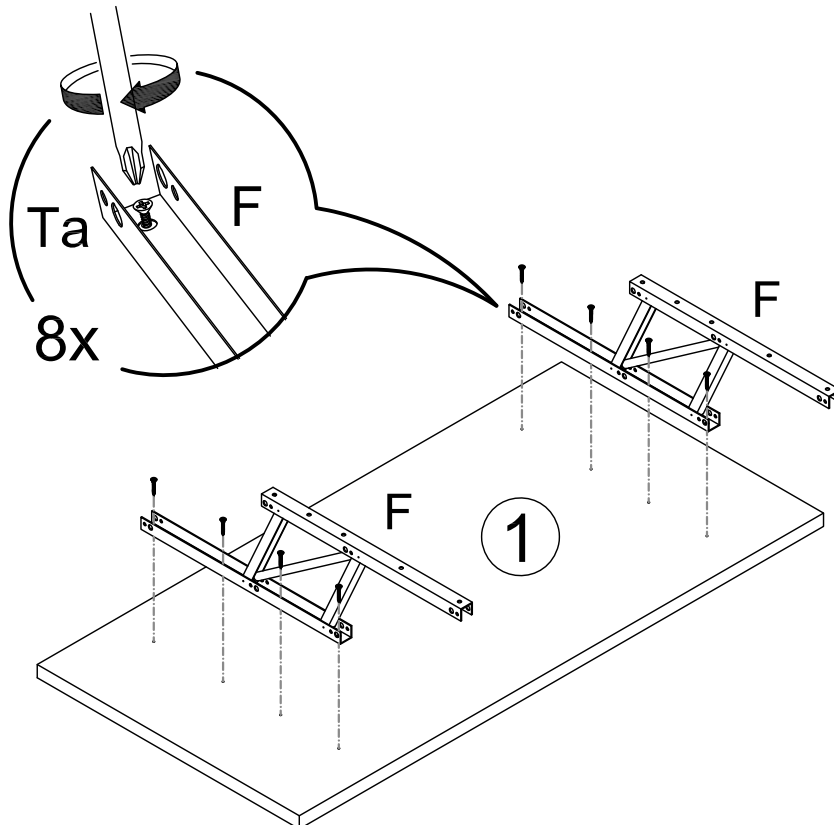
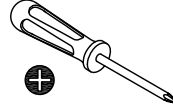
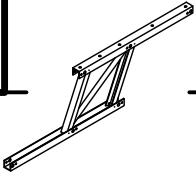

11

Ta x6

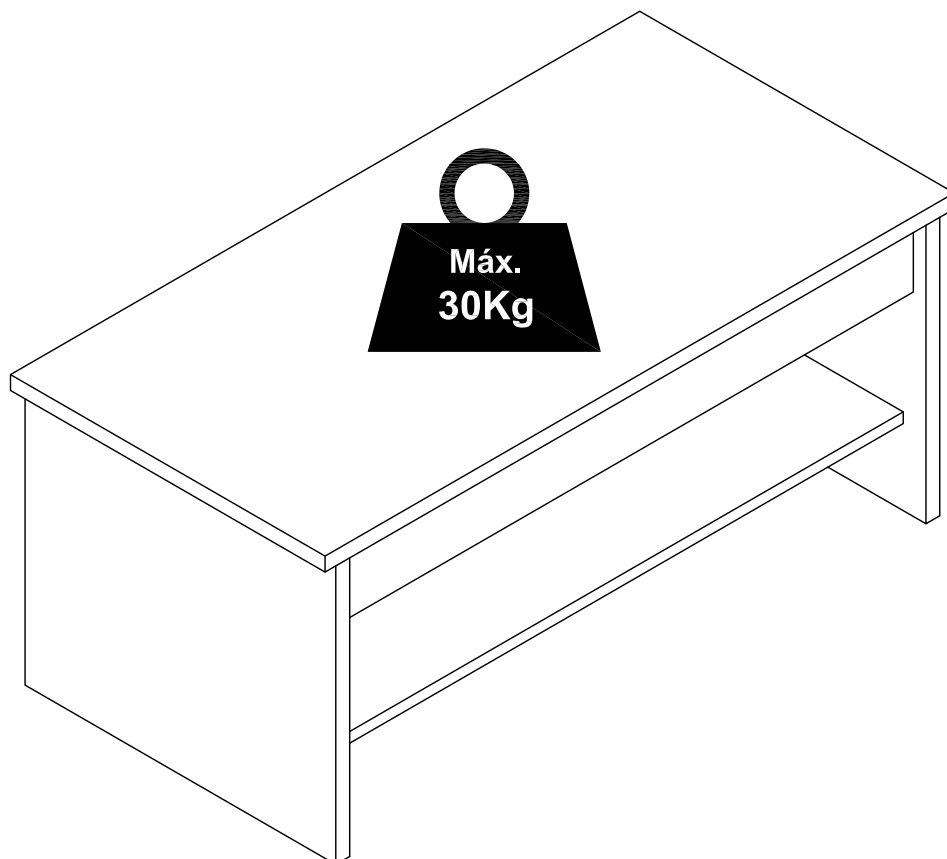
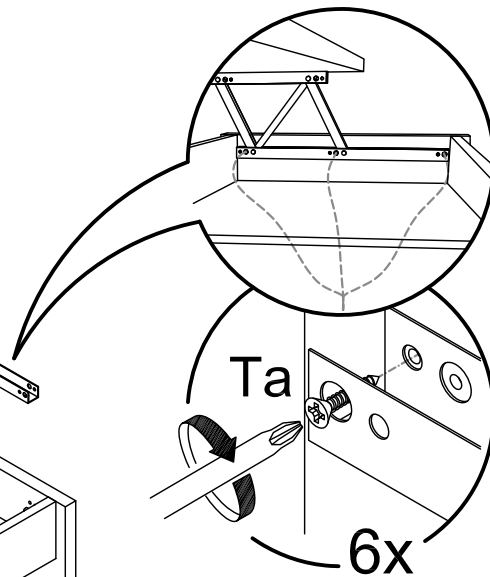
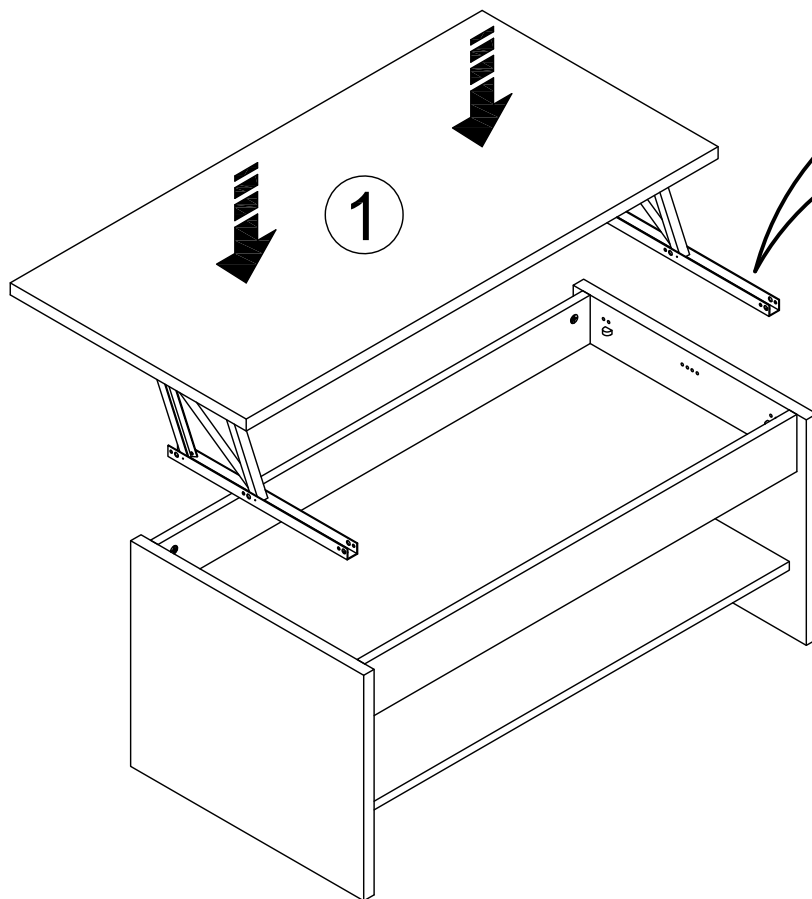
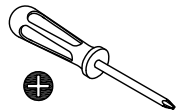

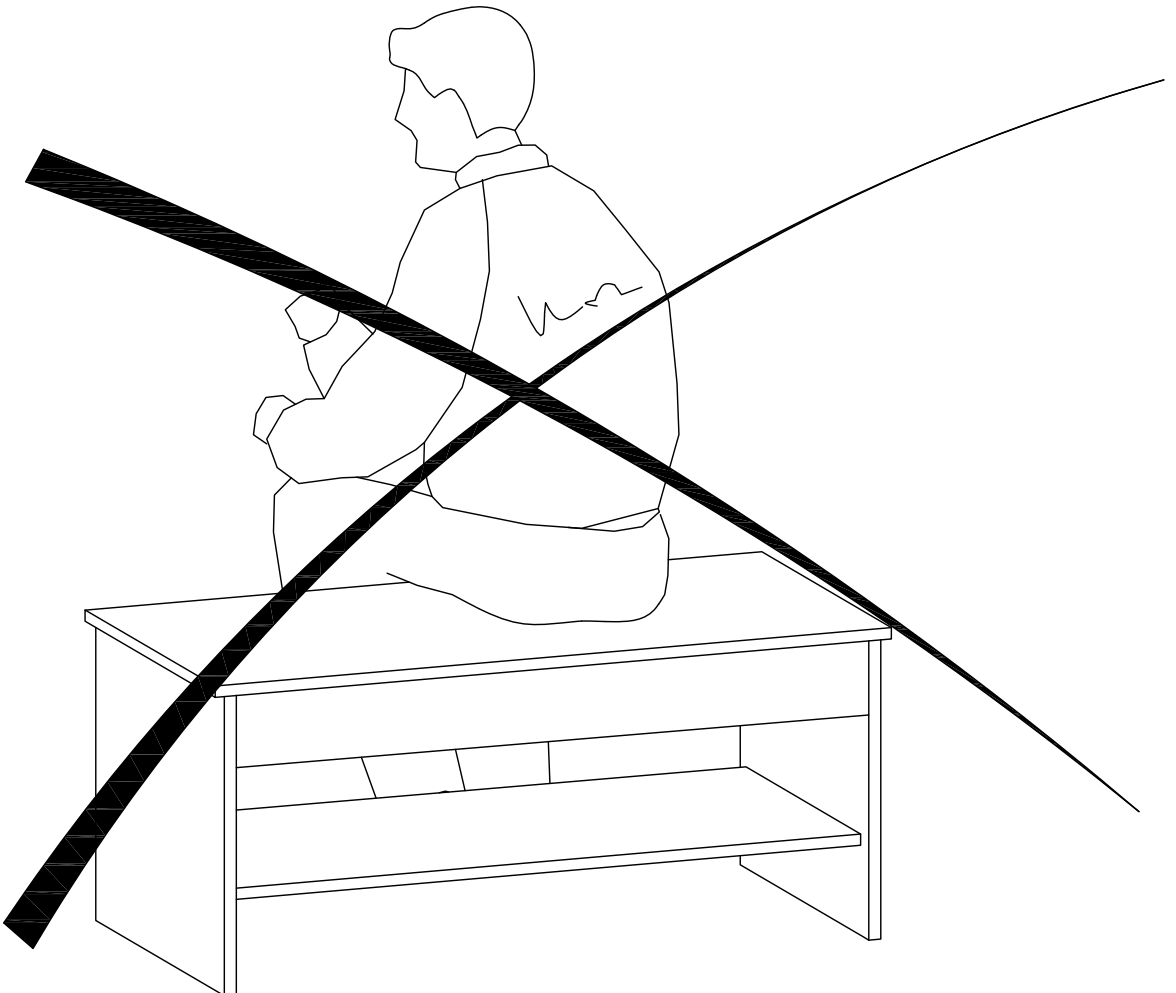
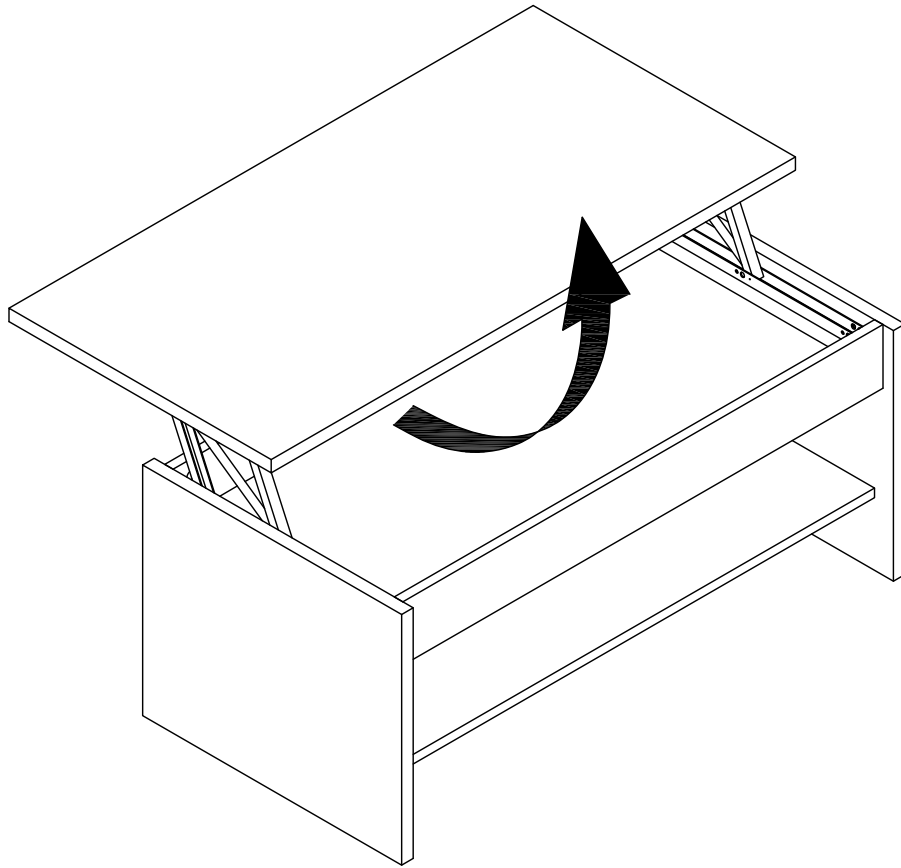

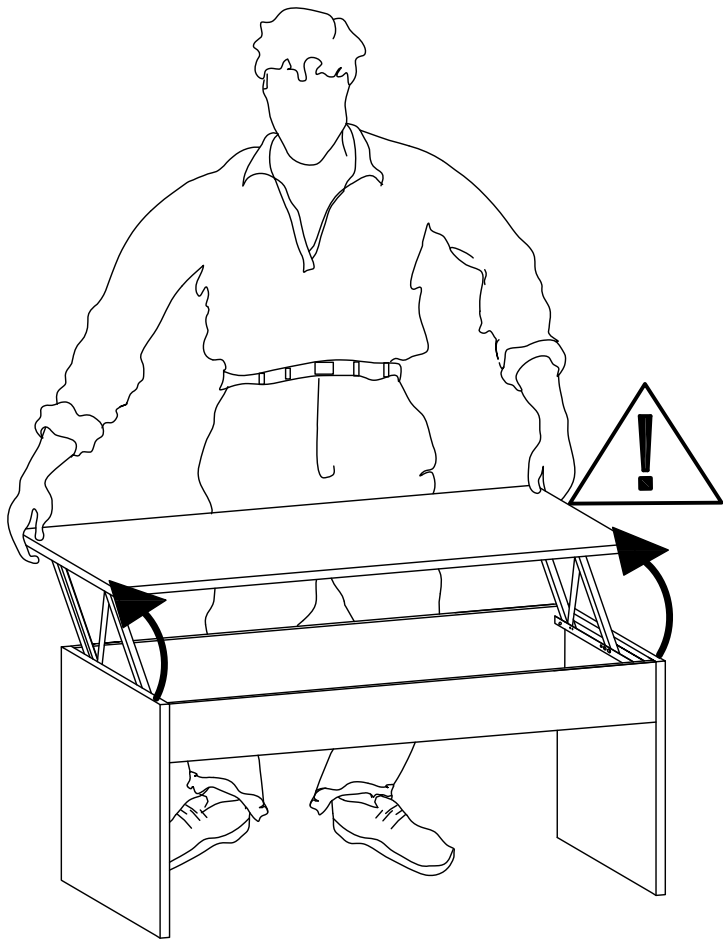

ATTENTION:



- FR** - ACCOMPAGNER LE MOUVEMENT AU MOMENT D'OUVRIR LE PLATEAU POUR EVITER DES MOUVEMENTS BRUSQUES.
- EN** - PLEASE TAKE CARE WHEN GETTING THE TOP UP FOR AVOIDING A BRUSQUE ELEVATION.
- PT** - ACOMPANHE O MOVIMENTO NO MOMENT ABRA A BANDEJA PARA EVITAR MOVIMENTOS BRUSCOS.
- DE** - UM EINEN HARTEN AUFSTIEG ZU VERMEIDEN, BEGLEITEN SIE DEN DECKEL, WENN SIE IHN ANHEBEN.
- ES** - ACOMPAÑE LA TAPA CUANDO LA ELEVE PARA EVITAR UNA SUBIDA BRUSCA.
- IT** - ACCOMPAGNARE IL COPERCHIO QUANDO L'ELEVI PER EVITARE UNA SALITA BRUSCA.

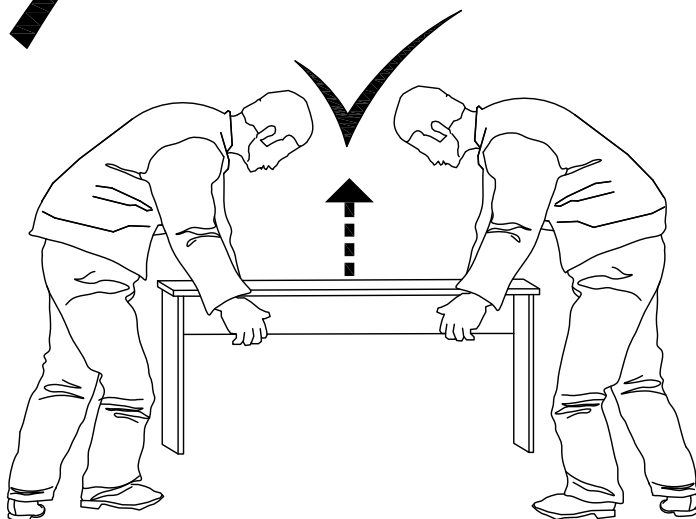
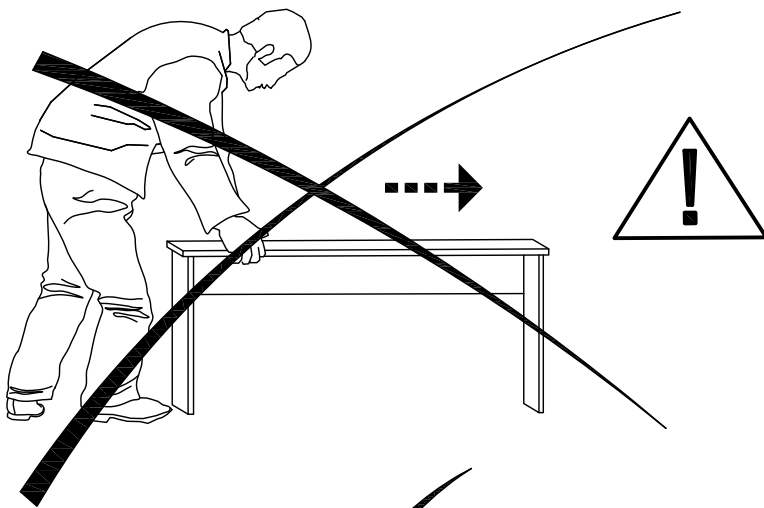

ATTENTION:



- FR** - NE PAS TRAINER. LEVER LA TABLE AVEC AIDE POUR LA DÉPLACER.
- EN** - PLEASE DO NOT DRAG. TO MOVE THE TABLE, PLEASE RAISE IT WITH HELP.
- PT** - POR FAVOR, NÃO ARRASTE. PARA MOVER A MESA, POR FAVOR, LEVANTE-A COM AJUDA.
- DE** - BITTE NICHT SCHLEPPEN. UM DEN TABELLEN ZU VERSCHIEBEN, BITTE SIE MIT HILFE
- ES** - NO ARRASTRAR. PARA DESPLAZAR LA MESA, LEVANTELA CON AYUDA.
- IT** - NON TRASCINARE. PER ELEVARE LA TAVOLA, FALLO TRA DUE PERSONE.

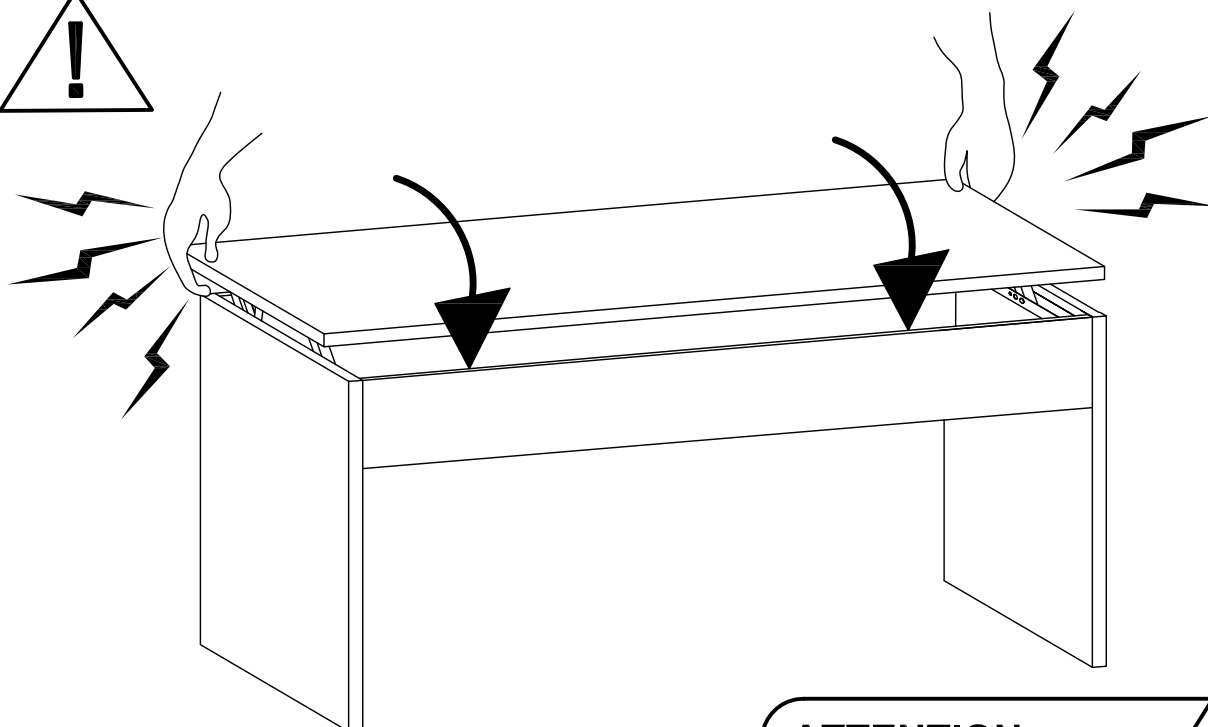

ATTENTION:

- FR-** RISQUE DE BLESSURE, FERMER AVEC PRUDENCE
- EN-** RISK OF INJURY, CLOSE CAREFULLY
- PT-** RISCO DE LESÕES, FECHER COM CUIDADO
- DE-** VERLETZUNGSGEFAHR, SORGFÄLTIG VERSCHLIESSEN
- ES-** PELIGRO DE LESIONES, CERRAR CON CUIDADO
- IT-** RISCHIO DI LESIONI, CHIUDERE CON ATTENZIONE



ATTENTION:

- FR-** L'UTILISATION PAR LES ENFANTS EST INTERDITE, DANGER DE BLESSURE
- EN-** USE BY CHILDREN IS PROHIBITED, DANGER OF INJURY
- PT-** É PROIBIDO O USO POR CRIANÇAS, PERIGO DE LESÕES
- DE-** DIE NUTZUNG DURCH KINDER IST VERBOTEN, VERLETZUNGSGEFAHR
- ES-** PROHIBIDO EL USO POR NIÑOS, PELIGRO DE LESIONES
- IT-** E' VIETATO L'UTILIZZO AI BAMBINI, PERICOLO DI LESIONI

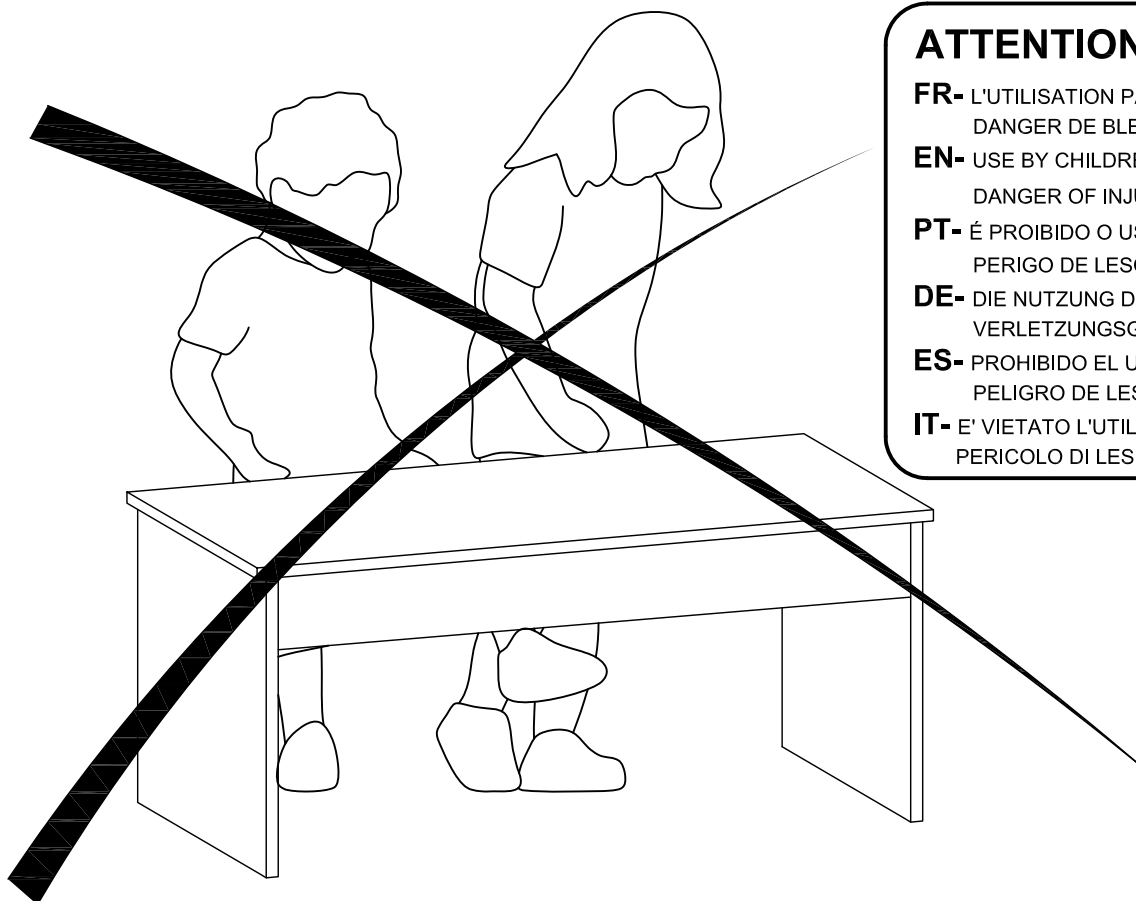

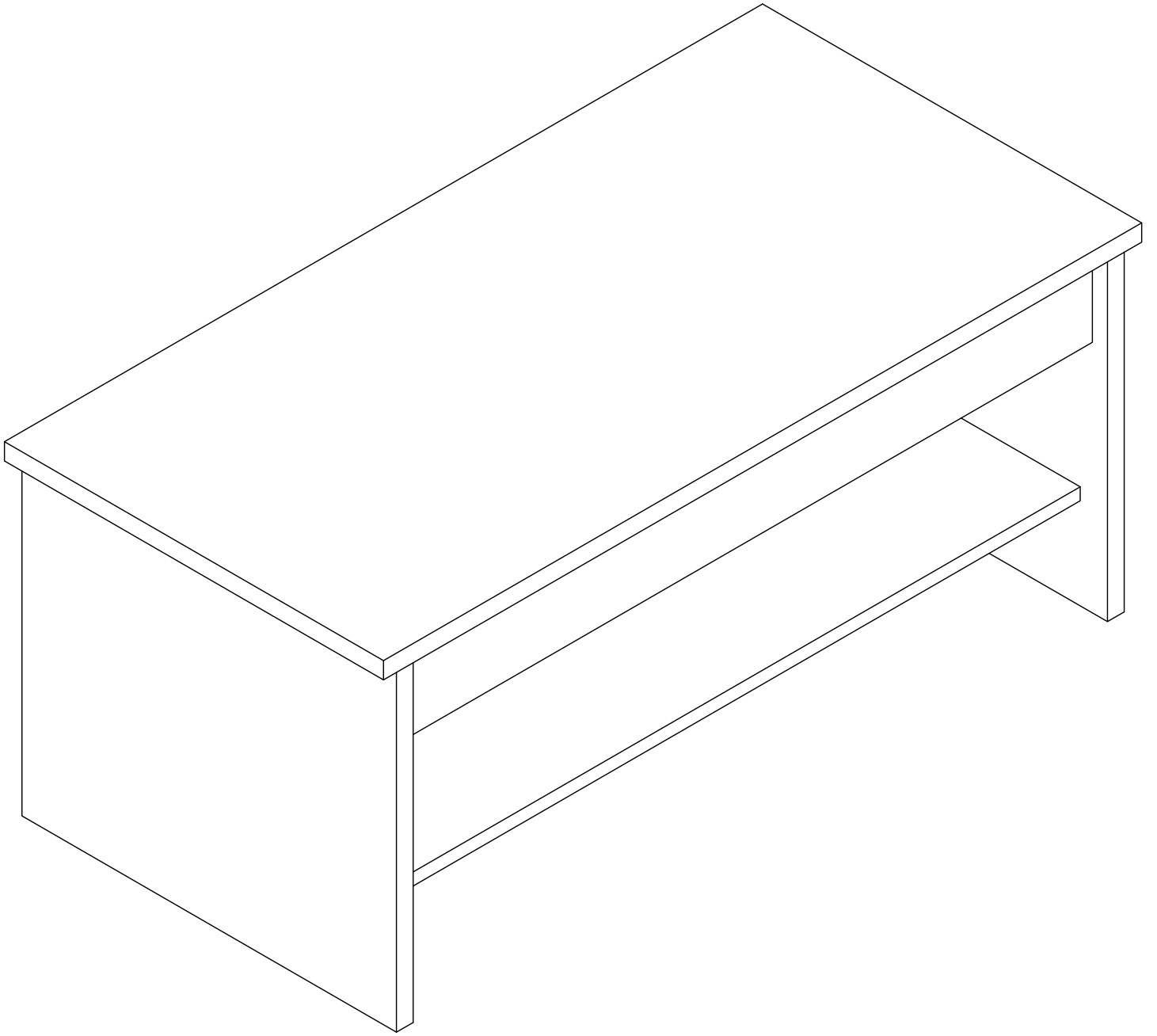

FRANÇAIS - SUISSE

CONSEILS DE MONTAGE:

- 1 > BIEN ÉTUDIER LA NOTICE DE MONTAGE.
- 2 > RÉPÉREZ LES PIÈCES CONSTITUANT VOTRE MEUBLE.
- 3 > REGROUPEZ ET CONTROLEZ LA QUINCAILLERIE.
- 4 > MUNISSEZ-VOUS DE L'OUTILLAGE NÉCESSAIRE.
- 5 > AMÉNAGEZ-VOUS UNE ZONE DE MONTAGE.
- 6 > PROCÉDEZ AU MONTAGE.



NE JAMAIS FORCER LES ASSEMBLAGES.
RESSERREZ LES VIS APRÈS QUELQUES TEMPS D'USAGES.
GARDER VOTRE NOTICE DE MONTAGE, SI UNE PIÈCE
VENAIT A MANQUER, ELLE SERAIT LE PLUS CLAIR
MOYEN DE COMMUNIQUER AVEC VOTRE MAGASIN.

CONSEILS D'ENTRETIEN:

- 1 > DÉPOUSSIÉREZ SOIGNEUSEMENT.
- 2 > UTILISEZ UN CHIFFON SEC.



- NE JAMAIS UTILISER DE PRODUITS ABRASIFS: LAINE D'ACIER, SOLVANTS.
- NE PAS MOUILLER.

	PAPIER DÉCOR	SURFACES STRATIFIÉES	SURFACES LAQUÉES	BOIS VERNIS	TEXTILE CUIR
EAU SAVONNEUSE (SAVON NEUTRE)	○	○	○	○	○
EAU ADDITIONNÉE		○	○		
ENTRETIEN SPÉCIFIQUE FABRICANT					○

DEUTSCH - SCHWEIZ

MONTAGE ANLEITUNG:

- 1 > DIE MONTAGE ANLEITUNG SORGFÄLTIG DURCHLESEN.
- 2 > DIE EINZELTEILE DES MÖBELSTÜCKS ERMITTELN.
- 3 > DIE BESCHLÄGE ZUSAMMENLEGEN UND PRÜFEN.
- 4 > DAS NOTWENDIGE WERKZEUG ZURECHTLEGEN.
- 5 > EINEN MONTAGEBEREICH FREIMACHEN.
- 6 > DAS MÖBELSTÜCK ZUSAMMENBAUEN.



NIEMALS DIE VERBINDUNGEN ZU STARK ANZIEHEN.
DIE SCHRAUBEN NACH EINIGER ZEIT DES GEBRAUCHS
ERNEUT FESTZIEHEN. DIE MONTAGE ANLEITUNG GUT
AUFBEWAHREN. SOLLTE EIN TEIL FEHLEN, IST SIE DAS
BESTE VERSTÄNDIGUNGSMITTEL MIT IHREM GESCHÄFT.

PFLEGEHINWEISE:

- 1 > SORGFÄLTIG ENTSTAUBEN.
- 2 > VERWENDEN SIE EIN TROCKENES TUCH.



- BENUTZEN SIE KEINE SCHEUERMITTEL WIE: STAHLWOLLE, LÖSUNGSMITTEL.
- KEIN WASSER VERWENDEN.

	DEKORPAPIER	OVERFLÄCHE LAMINAT	OVERFLÄCHE LACK	LACKIERTEM HOLZ	TEXTIL LEDER
SEIFENLAUGE (NEUTRAL SEIFE)	○	○	○	○	○
WASSER MIT HAUSHALTSREINIGER		○	○		
PRODUZENT SPEZIFISCHER UNTERHALI					○

ITALIANO - SVIZZERA

CONSIGLI DI MONTAGGIO:

- 1 > STUDIARE BENE LE ISTRUZIONI DI MONTAGGIO.
- 2 > RICONOSCERE I PEZZI CHE COSTITUISCONO IL MOBILE.
- 3 > RAGGRUPPARE E CONTROLLARE LA FERRAMENTA.
- 4 > MUNIRSI DEGLI UTENSILI NECESSARI.
- 5 > PREPARARE UNA ZONA DI MONTAGGIO.
- 6 > PROCEDERE AL MONTAGGIO.



NON FORZARE MAI GLI ASSEMBLAGGI.
RISTRINGERE LE VITI DOPO UN PERIODO D'USO.
CONSERVARE QUESTE ISTRUZIONI DI MONTAGGIO, SE
UN PEZZO VENISSE A MANCARE SAREBBE IL MIGLIORE
MEZZO DI COMUNICAZIONE CON IL REVENDITORE.

CONSIGLI PER LA MANUTENZIONE:

- 1 > SPOLVERATE ACCURATAMENTE.
- 2 > USARE UN PANNINO ASCIUTTO.



- NON UTILIZZARE MAI PRODOTTI ABRASIVI: LANA DI ACCIAIO, SOLVENTI.
- NON BAGNARE.

	CARTA	SUPERFICIE STRATIFICATE	SUPERFICIE LACCATE	LACCATE EGNO VERNICIATO	TESSILE CUOTO
ACQUA CON SAPONE (SAPONE NEUTRO)	○	○	○	○	○
ACQUA CON DETERSIVO		○	○		
MANUTENZIONE SPECIFICA PRODUTTORE					○

ENGLISH

ASSEMBLY ADVICE:

- 1 > CAREFULLY READ THE ASSEMBLY INSTRUCTION.
- 2 > IDENTIFY THE COMPONENTS OF THE FURNITURE.
- 3 > GROUP AND CHECK THE HARDWARE.
- 4 > USE THE REQUIRED TOOLS.
- 5 > CREATE AN ASSEMBLY ZONE.
- 6 > MAKE THE ASSEMBLY.



NEVER FORCE THE CONNECTIONS.
RE-TIGHTEN THE SCREWS AFTER FEW DAYS.
PLEASE RETAIN THE AI LEAFLET FOR FUTURE REFERENCE,
THE AI CONTAINS INFORMATION WHEN CLAIMING
FOR MISSING PARTS.

CLEANING ADVICE:

- 1 > CAREFULLY REMOVE THE DUST.
- 2 > USE A SOFT AND CLEAN CLOTH.



- NEVER USE ABRASIVE PRODUCTS OR SOLVENTS.
- DO NOT USE APPLY EXCESSIVE PRESSURE WHEN USING THE DAMP CLOTH.

	PAPER DECOR	LAMINATED SURFACES	LACQUERED SURFACES	VARNISHED WOOD	LEATHER TEXTILE
SOAPY WATER (NEUTRAL SOAP)	<input type="radio"/>	<input type="radio"/>	<input type="radio"/>	<input type="radio"/>	<input type="radio"/>
WATER WITH DETERGENT		<input type="radio"/>	<input type="radio"/>		
SPECIFIC SUPPLIER CLEANING					<input type="radio"/>

ESPAÑOL

CONSEJOS PARA EL MONTAJE:

- 1 > ESTUDIE ATENTAMENTE EL MANUAL DE MONTAJE.
- 2 > LOCALICE LA PIEZAS QUE CONSTITUYEN EL MUEBLE.
- 3 > REUNA Y CONTROLE EL HERRAJE.
- 4 > EQUIPESE DE LAS HERRAMIENTAS NECESARIAS.
- 5 > PREPARE UNA ZONA DE MONTAJE.
- 6 > REALICE EL MONTAJE.



NO FUERCE NUNCA LAS UNIONES. APRIETE LOS TORNILLOS DESPUÉS DE CIERTO TIEMPO DE UTILIZACIÓN. CONSERVE SU MANUAL DE MONTAJE, SI FALTARA UNA PIEZA SERÍA LA MANERA MÁS FÁCIL DE COMUNICAR CON LA TIENDA.

CONSEJOS PARA EL MANTENIMIENTO:

- 1 > QUITAR EL POLVO CUIDADOSAMENTE.
- 2 > UTILICE UN PAÑO LIMPIO Y SECO.



- NO USE NUNCA PRODUCTOS ABRASIVOS COMO: LANA DE ACERO O DISOLVENTES.
- NO MOJAR.

	PAPEL DECORATIVO	SUPERFICIE LAMINADA	SUPERFICIE LACADA	MADERA BARNIZADA	TEXTIL CUERO
AGUA Y JABÓN (JABÓN NEUTRO)	<input type="radio"/>	<input type="radio"/>	<input type="radio"/>	<input type="radio"/>	<input type="radio"/>
AGUA CON DETERGENTE		<input type="radio"/>	<input type="radio"/>		
MANTENIMIENTO ESPECÍFICO DEL FABRICANTE					<input type="radio"/>

NEDERLANDS

MONTAGETIPS:

- 1 > LEES DE MONTAGE-INSTRUCTIES ZORGVULDIG DOOR.
- 2 > IDENTIFICEER ALLE ONDERDELEN VAN UW MEUBEL.
- 3 > VERZAMEL EN CONTROLEER HET INZERWAREN.
- 4 > NEEM HET BENODIGDE GEREEDSCHAP.
- 5 > MAAK EEN ZONE VRIJ VOOR DE MONTAGE.
- 6 > GA VERDER MET DE MONTAGE.



FORCEER NOOIT DE VERBINDINGEN. DRAAI DE SCHROEVEN OPNIEUW VAST NA EEN PAAR DAGEN. BEWAAR UW MONTAGE-INSTRUCTIES. ZIJN DE DUIDELJKSTE MIDDEL OM MET DE WINKEL TE COMMUNICEREN WANNEER EEN ONDERDEEL ONTBREEKT.

ONDERHOUDSTIPS:

- 1 > ZORGVULDIG AFSTOFFEN.
- 2 > GEBRUIK EEN DROGE DOEK.



- GEBRUIK GEEN SCHUREND PRODUCT: STAAWOL, OPLOSMIDDELEN.
- MAAK HET NIET NAT.

	DECOR PAPIER	GELAMINEERDE OPPERVLAKTES	GELAKTE OPPERVLAKTES	HOUT VERNIS	TEXTIEL LEDER
ZEEPWATER	<input type="radio"/>	<input type="radio"/>	<input type="radio"/>	<input type="radio"/>	<input type="radio"/>
WATER MET WASMIDDEL		<input type="radio"/>	<input type="radio"/>		
SPECIFIEK ONDERHOUD FABRIKANT					<input type="radio"/>

PORTUGUÊS

CONSELHOS DE MOTAGEM:

- 1 > ESTUDE BEM AS INSTRUÇÕES DE MONTAGEM.
- 2 > REUNA AS PEÇAS QUE CONSTITUEM O SEU MÓVEL.
- 3 > REAGRUPE AS FERRAGENS.
- 4 > EQUIPE-SE COM AS FERRAMENTAS NECESSÁRIAS.
- 5 > PREPARE UMA ÁREA PARA A MONTAGEM.
- 6 > INICIE A MONTAGEM.

CONSELHOS PARA A MANUTENÇÃO:

- 1 > ELIMINAR BEM O PÓ.
- 2 > USAR PANO SECO.



- NUNCA UTILIZAR PRODUTOS ABRASIVOS: LÃ DE AÇO OU SOLVENTES.
- NÃO MOLHAR.

NUNCA FORÇAR OS ENCAIXES.
REAPERTAR OS PARAFUSOS APÓS UM TEMPO DE UTILIZAÇÃO. GUARDAR AS INSTRUÇÕES DE MONTAGEM. CASO FALTE ALGUMA PEÇA, O MAIS ACONSELHÁVEL É CONTATAR O REVENDEDOR.

	ACABAMENTO IMITAÇÃO	SUPERFÍCIES ESTRATIFICADAS	SUPERFÍCIES LACADAS	MADEIRA ENVERNIZADA	TEXTIS PELES
ÁGUA COM SABÃO (JSABÃO NEUTRO)	○	○	○	○	○
ÁGUA COM DETERGENTE		○	○		
INSTRUÇÕES ESPECÍFICAS DO FABRICANTE					○

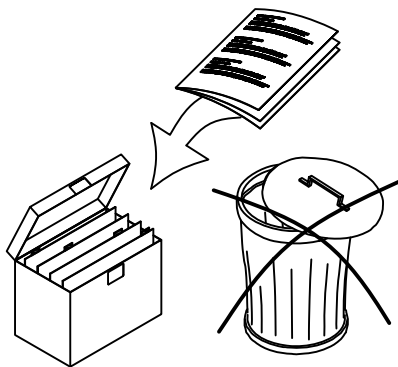

FR

Donnez ou recyclez vos meubles.



Association

ou



Magasin

ou



Déchèterie

<https://quefairedemesdechets.fr>