

Einbauanleitung

Installation Instruction

N621P334120
N621P334121

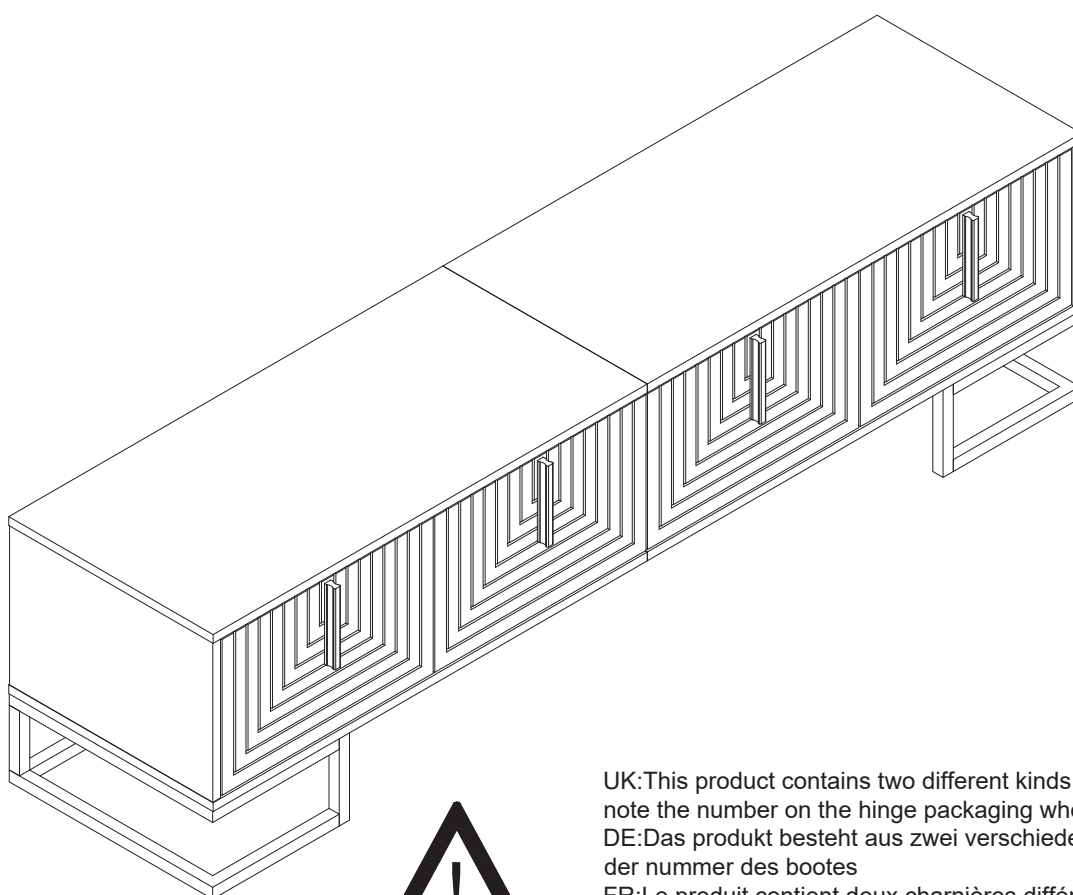

UK: This product contains two different kinds of hinges, please note the number on the hinge packaging when installing
DE: Das produkt besteht aus zwei verschiedenen scharniere mit der nummer des bootes
FR: Le produit contient deux charnières différentes. Lors de l'installation, veuillez prêter attention au numéro sur l'emballage de la charnière

Our product will be delivered to you in 2 packages. The delivery times of these 2 packages may differ, please be patient and thank you for your understanding.

Unser Produkt wird Ihnen in 2 Paketen geliefert. Die Lieferzeiten dieser 2 Pakete können abweichen, bitte haben Sie etwas Geduld und vielen Dank für Ihr Verständnis

Notre produit vous sera livré en 2 colis. Les délais de livraison de ces 2 colis peuvent différer, soyez patient et merci de votre compréhension



[DE]

Warnung: Lesen Sie die Anleitung vor dem Zusammenbau bitte vollständig durch. Überprüfen Sie, ob Sie alle auf den Seiten aufgeführten Komponenten und Werkzeuge haben.

Warnung: Legen Sie alle Teile auf eine ebene Fläche. Legen Sie eine weiche Decke oder Ähnliches darunter, um sie vor Kratzern oder Flecken zu schützen. Vermeiden Sie es, Komponenten über den Boden zu ziehen oder zu schieben.

Warnung: Überprüfen Sie regelmäßig alle Beschläge und Befestigungen, um sicherzustellen, dass sie sicher sind und um Unfälle zu vermeiden. Wenn Teile fehlen, kaputt, beschädigt oder abgenutzt sind, verwenden Sie das Produkt nicht weiter, bis es mit vom Hersteller autorisierten Teilen repariert wurde.

Warnung: Lassen Sie Kinder nicht auf die Möbel klettern, da dies zum Umkippen und zu schweren Verletzungen führen kann. Bauen Sie die Möbel außerhalb der Reichweite von Kindern zusammen.

Warnung: Stellen Sie die Möbel nicht in die Nähe von Feuerquellen oder heißen Gegenständen, um Brandgefahr zu vermeiden.

Warnung: Reinigen Sie die Möbel mit einem feuchten Tuch oder Alkohol. Verwenden Sie keine Reinigungsmittel mit ätzenden Chemikalien.

Warnung: Dieses Produkt ist mit einer Kippschutzvorrichtung ausgestattet. Bitte installieren Sie diese Vorrichtung unbedingt, um unnötige Verletzungen durch Umkippen zu vermeiden.

[EN]

Warning: Please read instructions fully before starting assembly. Check you have all the components and tools listed on pages.

Warning: Please place all parts on a flat surface. Place a soft blanket or similar underneath to protect against scratches or stains. Avoid dragging or sliding components across the floor.

Warning: Regularly check all fittings and fastenings to ensure they are secure and to prevent accidents. If any parts are missing, broken, damaged, or worn, discontinue use of the product until repairs have been made using factory authorized parts.

Warning: Do not allow children to climb on the furniture as this may result in tipping and serious personal injury. Assemble the furniture away from the reach of children.

Warning: Do not place furniture close to fire sources or high-temperature objects to avoid the risk of fire.

Warning: Clean furniture with a damp cloth or alcohol, avoid using cleaning agents containing corrosive chemicals.

Warning: This product is equipped with an anti-tilt device. Please be sure to install this device to prevent unnecessary injuries caused by tipping.

[FR]

Avertissement : Veuillez lire entièrement les instructions avant de commencer l'assemblage. Vérifiez que vous disposez de tous les composants et outils répertoriés sur les pages.

Avertissement : Veuillez placer toutes les pièces sur une surface plane. Placez une couverture douce ou similaire en dessous pour les protéger des rayures ou des taches. Évitez de faire glisser les composants sur le sol.

Avertissement : Vérifiez régulièrement tous les raccords et fixations pour vous assurer qu'ils sont bien fixés et pour éviter les accidents. Si des pièces manquent, sont cassées, endommagées ou usées, cessez d'utiliser le produit jusqu'à ce que des réparations aient été effectuées à l'aide de pièces autorisées par l'usine.

Avertissement : Ne laissez pas les enfants grimper sur les meubles car cela pourrait entraîner un basculement et des blessures graves. Assemblez les meubles hors de portée des enfants.

Avertissement : Ne placez pas les meubles à proximité de sources de feu ou d'objets à haute température pour éviter tout risque d'incendie.



Avertissement : Nettoyez les meubles avec un chiffon humide ou de l'alcool, évitez d'utiliser des produits de nettoyage contenant des produits chimiques corrosifs.

Avertissement : Ce produit est équipé d'un dispositif anti-basculement. Assurez-vous d'installer ce dispositif pour éviter les blessures inutiles causées par un basculement.

[IT]

Attenzione: leggere attentamente le istruzioni prima di iniziare il montaggio. Verificare di avere tutti i componenti e gli strumenti elencati nelle pagine.

Attenzione: posizionare tutte le parti su una superficie piana. Posizionare una coperta morbida o simile sotto per proteggere da graffi o macchie. Evitare di trascinare o far scivolare i componenti sul pavimento.

Attenzione: controllare regolarmente tutti i raccordi e i dispositivi di fissaggio per assicurarsi che siano sicuri e per prevenire incidenti. Se alcune parti sono mancanti, rotte, danneggiate o usurate, interrompere l'uso del prodotto fino a quando non siano state eseguite le riparazioni utilizzando parti autorizzate dalla fabbrica.

Attenzione: non consentire ai bambini di arrampicarsi sui mobili poiché ciò potrebbe causare ribaltamenti e gravi lesioni personali. Montare i mobili lontano dalla portata dei bambini.

Attenzione: non posizionare i mobili vicino a fonti di fuoco o oggetti ad alta temperatura per evitare il rischio di incendio.

Attenzione: pulire i mobili con un panno umido o alcol, evitare di utilizzare detergenti contenenti sostanze chimiche corrosive.

Attenzione: questo prodotto è dotato di un dispositivo antiribaltamento. Assicurarsi di installare questo dispositivo per prevenire lesioni inutili causate dal ribaltamento.

[ES]

Advertencia: Lea las instrucciones completamente antes de comenzar el montaje. Compruebe que tiene todos los componentes y herramientas que se enumeran en las páginas.

Advertencia: Coloque todas las piezas sobre una superficie plana. Coloque una manta suave o algo similar debajo para protegerlas de rayones o manchas. Evite arrastrar o deslizar los componentes por el piso.

Advertencia: Verifique regularmente todos los accesorios y fijaciones para asegurarse de que estén seguros y evitar accidentes. Si falta alguna pieza, está rota, dañada o desgastada, deje de usar el producto hasta que se hayan realizado las reparaciones con piezas autorizadas de fábrica.

Advertencia: No permita que los niños se suban a los muebles, ya que esto puede provocar que se vuelquen y lesiones personales graves. Monte los muebles fuera del alcance de los niños.

Advertencia: No coloque los muebles cerca de fuentes de fuego u objetos de alta temperatura para evitar el riesgo de incendio.

Advertencia: Limpie los muebles con un paño húmedo o alcohol, evite usar agentes de limpieza que contengan químicos corrosivos.

Advertencia: Este producto está equipado con un dispositivo antivuelco. Asegúrese de instalar este dispositivo para evitar lesiones innecesarias causadas por vuelcos.

Importeur	Decobus Handel GmbH
Adresse	Innungsstraße 9, 21244 Buchholz, Deutschland
Email/URL	https://www.decobusgroup.de
Hersteller	Shandong V&F Wood Co.,LTD.
Adresse	No.4,XingAn Road,Shouguang,Weifang,Shandong.China
Email/URL	https://www.vf-home.com
Partienummer	SKU:N621P334120-N621P334121
Hergestellt in	China



Decobus Handel GmbH

Innungsstraße 9,

21244 Buchholz,Deutschland

<https://www.decobusgroup.de>

EN

Dear customer,
Thank you for purchasing this product. So that your appliance serves you well, please read all the instructions in this user's manual. If you have any questions, please contact our customer care center.

FR

Cher client,
Nous vous remercions d'avoir acheté ce produit. Afin que vous puissiez profiter pleinement de votre appareil, veuillez lire toutes les instructions de ce manuel d'utilisation. Si vous avez la moindre question, veuillez contacter notre centre d'assistance à la clientèle.

DE

Sehr geehrter Kunde,
Vielen Dank, dass Sie dieses Produkt erworben haben. Damit Ihr Gerät Ihnen gute Dienste leistet, lesen Sie bitte alle Hinweise in diesem Benutzerhandbuch. Wenn Sie Fragen haben, wenden Sie sich bitte an unser Kundendienstzentrum.

ES

Queridos clientes,
Gracias por comprar este producto. Para que su electrodoméstico le sirva mejor, lea todas las instrucciones de este manual del usuario. Si tiene alguna pregunta, comuníquese con nuestro Centro de Atención al Cliente.

IT

Caro Cliente,
Grazie per aver acquistato questo prodotto. Per servirti meglio con questo apparecchio ti prego di leggere tutte le istruzioni in presente manuale utente. In caso di dubbio, si prega di contattare il nostro centro assistenza clienti.

USING CAM LOCK AND QUICKFIT

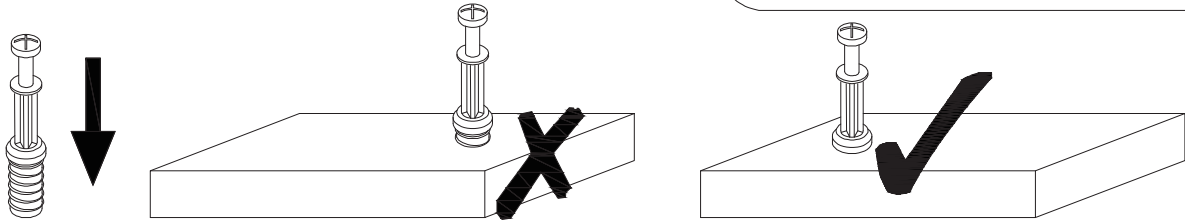

EN QUICKFIT: Tighten quickfit until shoulder is flush with panel. Do not overtighten or undertighten.

FR RACCORD RAPIDE: Faites serrer le raccord rapide jusqu'à ce que l'épaulement soit parfaitement encastré dans le panneau. Il ne faut ni trop serrer ni insuffisamment serrer.

ES QUICKFIT: Apriete quickfit hasta que el hombro se descargue con el panel. NO lo sobreapriete ni lo apriete poco.

DE QUICKFIT: Ziehen Sie den Quickfit fest, bis die Schulter mit der Platte bundig ist.

Bitte nicht zu fest oder zu schwach anziehen.

IT_MONTAGGIO RAPIDO: Stringere il montaggio rapido fino a quando la spalla è a filo con il pannello, non stringere troppo o troppo poco.

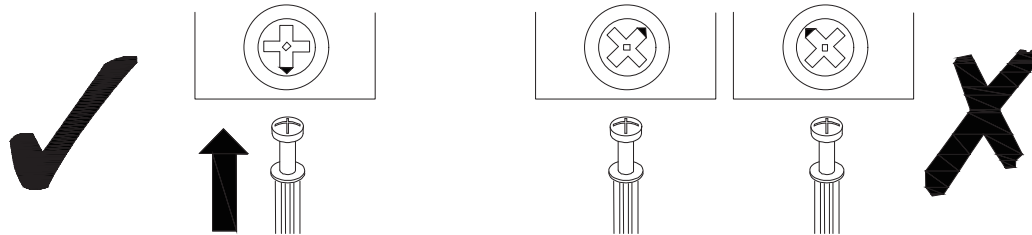

EN CAM LOCK: When fitting cam lock, ensure starting position is correct before you insert connecting quickfit.

FR SERRURE BATTEUSE: Avant d'insérer la serrure batteuse, veillez à la bonne orientation avant d'insérer le raccord rapide.

ES CIERRE DE LA CAMARA: Cuando instale el cierre de la cámara, asegúrese de que la posición de inicio es correcta antes de que inserte el quickfit conector.

DE_CAM-LOCK: Achten Sie bei der Montage des Cam-Locks auf die richtige Ausgangsposition, bevor Sie den Quickfit einsetzen.

IT_BLOCCAGGIO A CAMMA: Quando si monta il bloccaggio a camma, assicurarsi che la posizione iniziale sia corretta prima di inserire il montaggio rapido di collegamento.

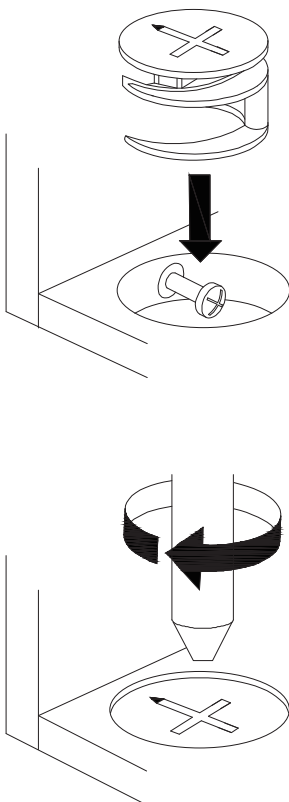

EN Quickfit head should be in the centre of the cam lock when the two panels are joined.

Cam lock should be inserted before quickfit.

FR Lorsque les deux panneaux sont assemblés, la tête du raccord rapide doit reposer au centre de la serrure batteuse.

Il faut insérer la serrure batteuse avant le raccord rapide.

ES El cabezal del quickfit debe estar en el centro del cierre de la cámara cuando se unan los dos paneles.

Se debe insertar el cierre de la cámara antes que el quickfit.

DE Der Quickfit-Kopf sollte sich in der Mitte des Cam-Locks befinden, wenn die beiden Platten zusammengefügt sind.

Der Cam-Lock sollte vor dem Quickfit eingesetzt werden.

IT La testa del montaggio rapido deve trovarsi al centro del bloccaggio a camma quando i due pannelli sono uniti.

Il Bloccaggio a Camma deve essere inserito prima del montaggio rapido.

EN Turn cam lock clockwise to tighten.

FR Faites tourner la serrure batteuse dans le sens des aiguilles d'une montre pour la resserrer.

ES Gire el cierre de la cámara en sentido horario para apretarlo.

DE Drehen Sie den Cam-Lock im Uhrzeigersinn, um ihn festzuziehen.

IT Ruotare il bloccaggio a camma in senso orario per stringere.

EN It may be necessary to adjust the hinges so that the doors align. Use the instructions below as a guide.

FR Il est parfois necessaire d'ajuster les charnieres pour un meilleur alignement des portes. Servez-vous des instructions ci-dessous comme guide.

ES Puede que sea necesario ajustar los quicios de forma que se alineen las puertas. Use las instrucciones que aparecen debajo como guía.

DE_Moglicherweise müssen Sie die Scharniere so einstellen, dass die Türen ausgerichtet sind. Verwenden Sie die nachstehenden Anweisungen als Leitfaden.

IT_Potrebbe essere necessario regolare le cerniere in modo che le porte siano allineate. Per fare ciò attenersi alle istruzioni sottostanti.

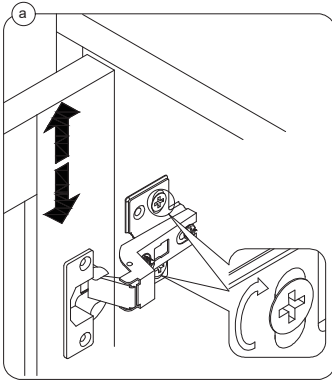

EN_To adjust the door vertically loosen the screw as shown and move up and down as needed.

FR_Si vous souhaitez regler la porte verticalement, desserrez la vis comme indique et deplacez la porte de haut en bas selon les besoins.

ES_Para ajustar la puerta verticalmente afloje el tornillo tal y como se muestra y muevalo hacia arriba o hacia abajo segun sea necesario.

DE_Um die Tür vertikal auszurichten, lösen Sie die Schraube wie abgebildet und bewegen Sie sie nach Bedarf nach oben oder nach unten.

IT_Per allineare la porta verticalmente allentare la vite come mostrato e spostarla in alto o in basso secondo necessita.

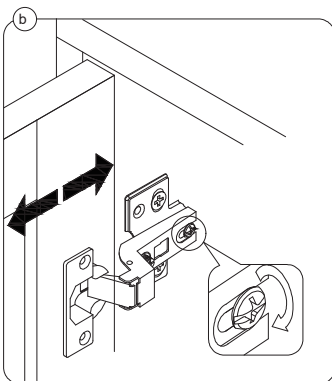

EN_To adjust the gap from the door to the main frame turn the screw clockwise or anti-clockwise as needed.

FR_Si vous souhaitez ajuster l'ecart entre la porte et le cadre principal, tournez la vis dans le sens des aiguilles d'une montre ou dans le sens inverse, si necessaire.

ES_Para ajustar el espacio desde la puerta al marco principal, gire el tornillo en sentido horario o antihorario, segun se necesite.

DE_Um den Abstand von der Tür zum Hauptrahmen auszurichten, drehen Sie die Schraube je nach Bedarf im oder gegen den Uhrzeigersinn.

IT_Per regolare lo spazio tra la porta e il telaio principale, avvitare o svitare la vite secondo necessita.

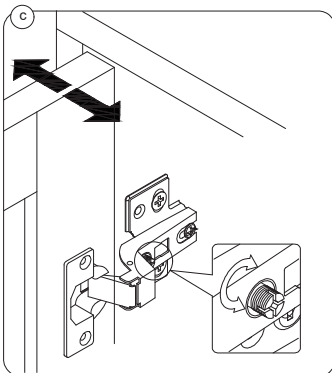

EN To adjust the door laterally adjust the screw as shown by turning clockwise or anti-clockwise.

FR_Si vous souhaitez ajuster la porte lateralement, ajustez la vis comme indique en tournant dans le sens des aiguilles d'une montre ou dans le sens inverse des aiguilles d'une montre.

ES_Para ajustar la puerta lateralmente ajuste el tornillo tal y como se muestra girandolo en sentido horario y antihorario.

DE_Um die Tür seitlich auszurichten, stellen Sie bitte die Schraube wie abgebildet durch Drehen im oder gegen den Uhrzeigersinn ein.

IT_Per allineare la porta lateralmente regolare la vite come mostrato, avvitandola o svitandola.

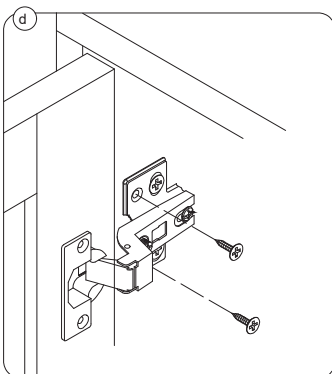

EN Please fix other screws

FR Merci de serrer les autres vis.

ES Fije los demas tornillos

DE Befestigen Sie bitte die anderen Schrauben

IT Fissare le altre viti

BOX-1 N621P334120

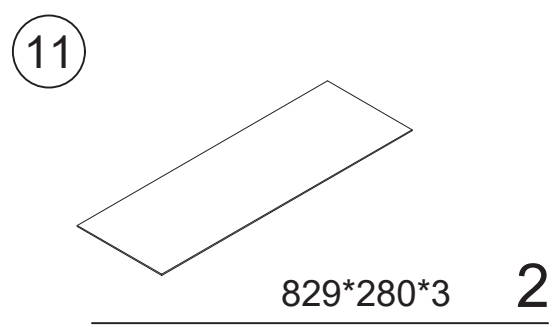
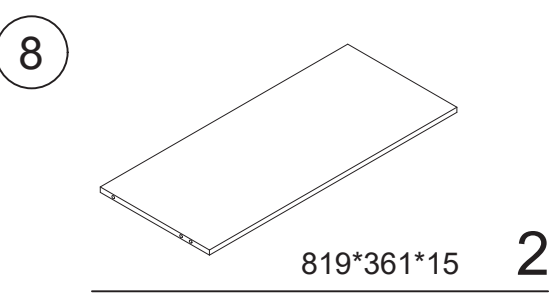
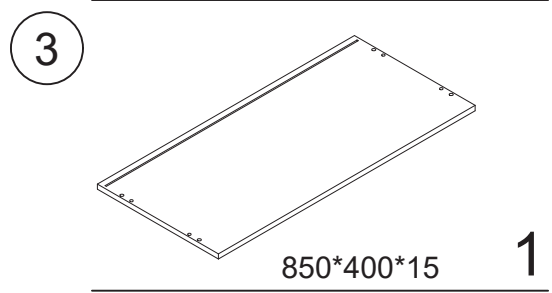
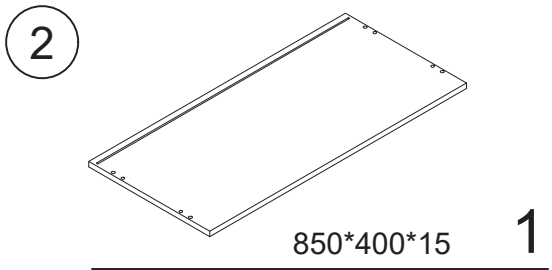
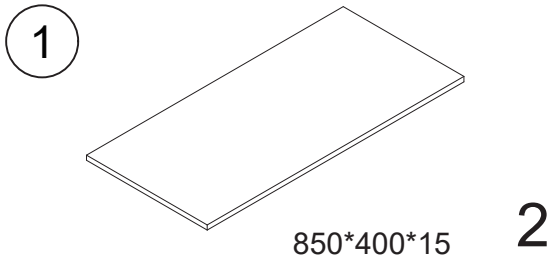

BOX-2 N621P334121

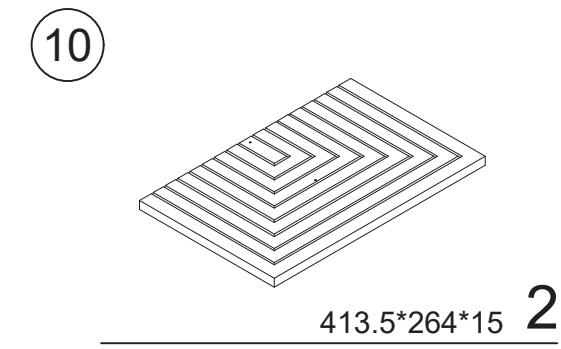
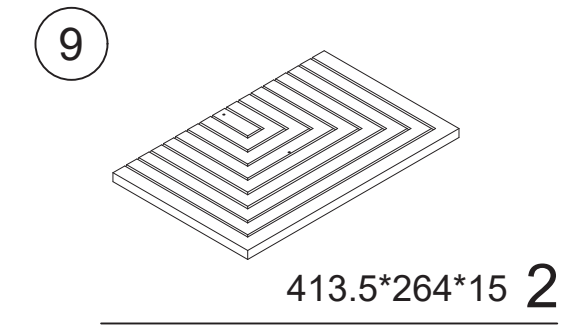
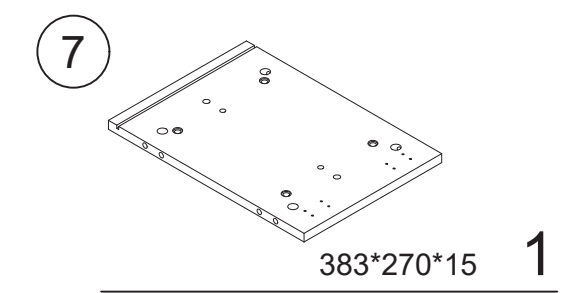
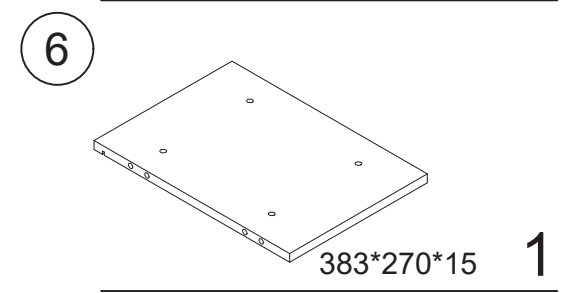
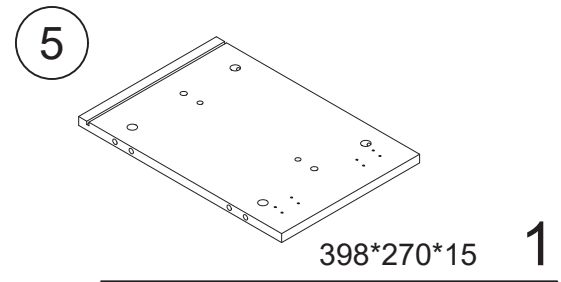
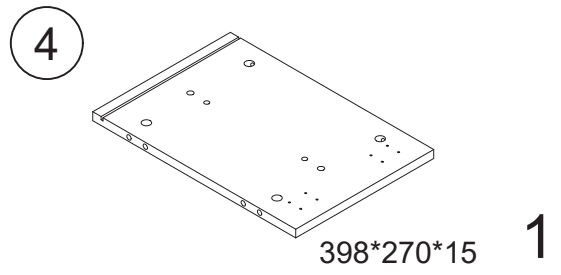

BOX-2 N621P334121

12

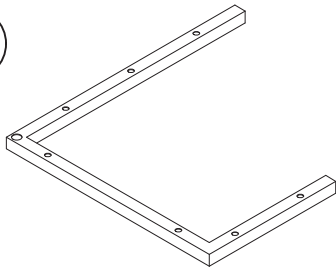

1

13

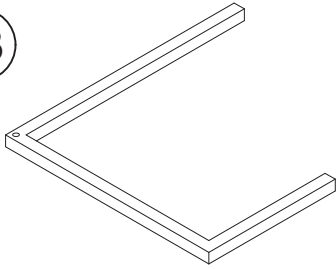

1

14

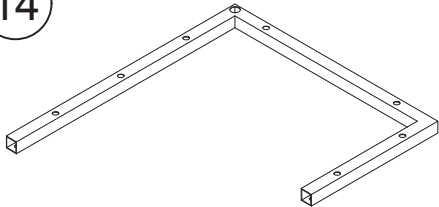

1

15

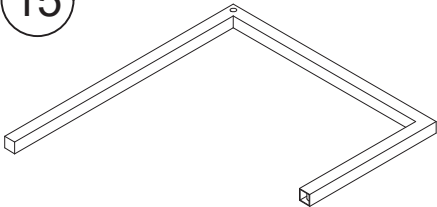

1

16

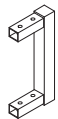

4

17



2

Hardware Box
Ein metallkästchen

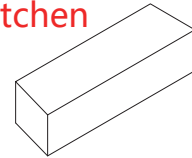

1

Montage Assembling

Geschätzte Zeit für die Montage

Estimated time for assembly



45 : 00

Was Sie brauchen

What you need

- Verwenden Sie den Verpackungskarton als Arbeitsfläche, um Produktschäden während der Montage zu vermeiden
- Kreuzschlitzschraubendreher
- Use the packaging carton as a working surface to prevent product damage during assembly
- Phillips head screwdriver

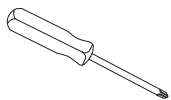

Gewichtsbeschränkung

Weight Limitation

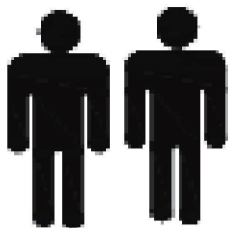

2 PERSONEN

2 PERSONS

Was ist enthalten What's included

Nr.	Beschreibung	Menge
Code	Description	Qty
A1		24
A2		24
B		24
C		72
D		4
E		4
F		12
G		4
H		8
I		1
J		13
K		4
L		24
M		20
N		14
P		2
Q		1
R		2
S		2

Die Hardware

The Hardware

<p>A</p> <p>24PCS</p>	<p>B</p> <p>24PCS</p>	<p>C</p> <p>72PCS</p>	<p>D</p> <p>4PCS</p>
<p>E</p> <p>4PCS</p>	<p>F</p> <p>12PCS</p>	<p>G</p> <p>4PCS</p>	<p>H</p> <p>8PCS</p>
<p>I</p> <p>1PCS</p>	<p>J</p> <p>13PCS</p>	<p>K</p> <p>4PCS</p>	<p>L</p> <p>24PCS</p>
<p>M</p> <p>20PCS</p>	<p>N</p> <p>14PCS</p>	<p>P</p> <p>2PCS</p>	<p>Q</p> <p>1PCS</p>
<p>R</p> <p>2PCS</p>	<p>S</p> <p>2PCS</p>		

WICHTIG:

1. ziehen sie die bolzen/schrauben nicht vollständig an, bis alle bolzen/schrauben ausgerichtet und in die löcher eingesetzt sind
2. schrauben und bolzen nicht zu fest anziehen, um ein ablösen zu vermeiden.
3. bitte verwenden sie handwerkzeuge, um dieses produkt zusammenzubauen. verwenden sie keine elektrowerkzeuge.

IMPORTANT:

1. do not tighten bolts / screws completely until all bolts / screws are lined up and inserted into holes.
2. do not over tighten screws and bolts to avoid stripping.
3. please use hand tools to assemble this product. do not use power tools.



2 PERSONEN
2 PERSONS

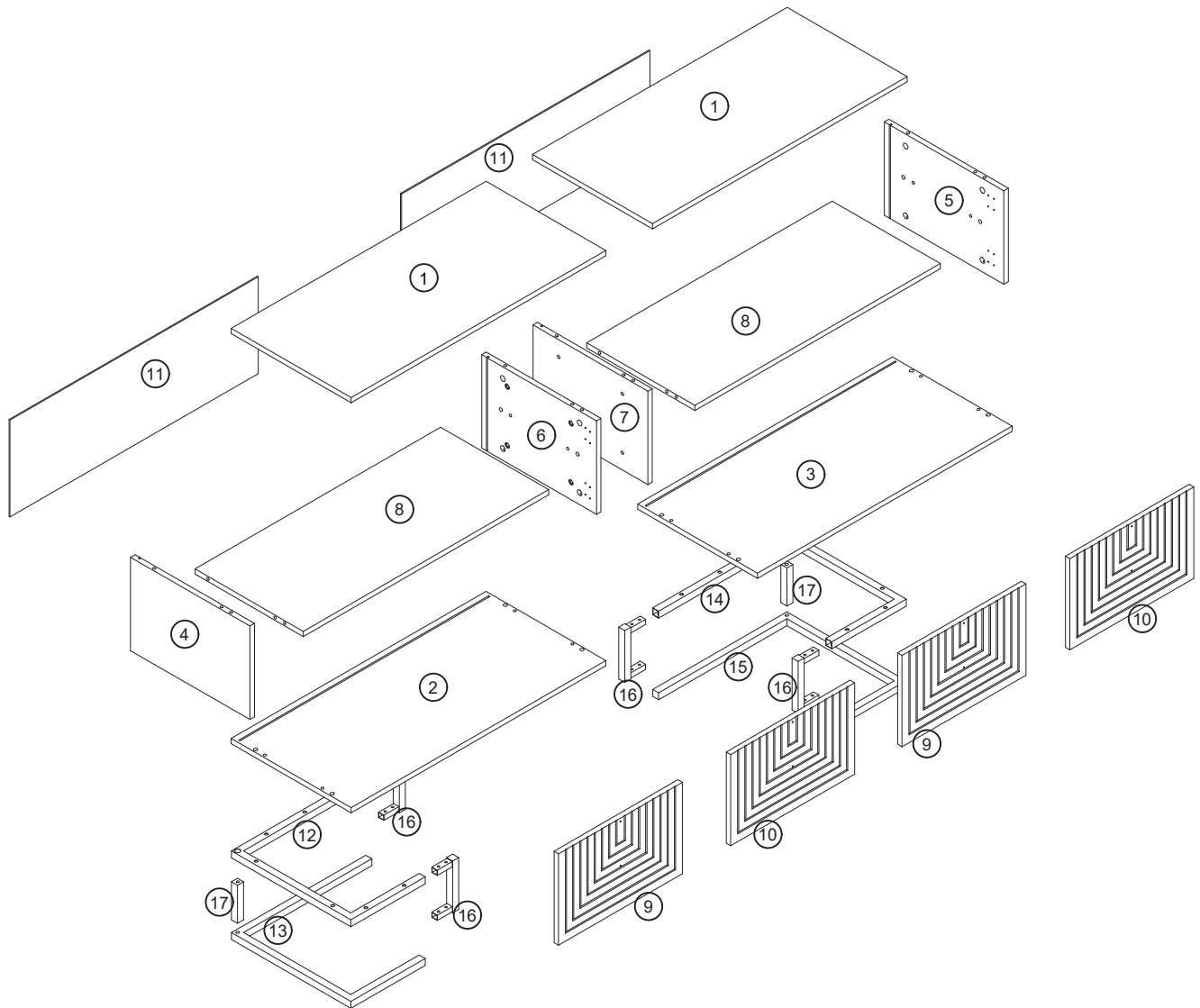

Enthaltenes Zubehör Included Accessories

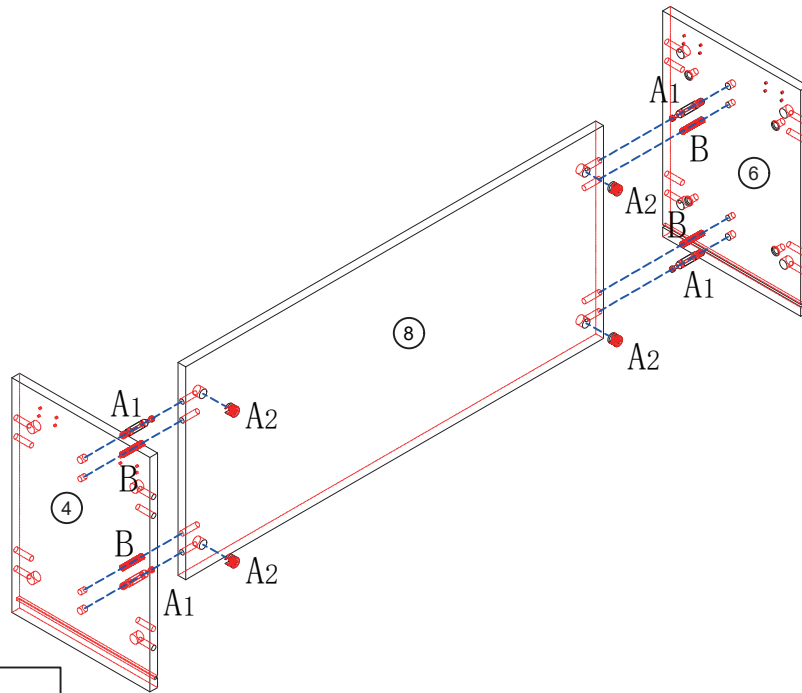

Schritt 1

Step 1





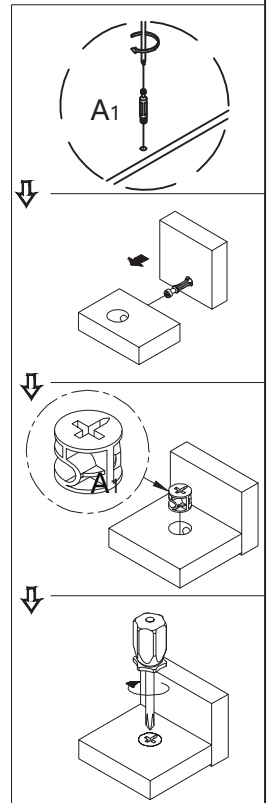

	A1x4pcs
	A2x4pcs
	Bx4pcs

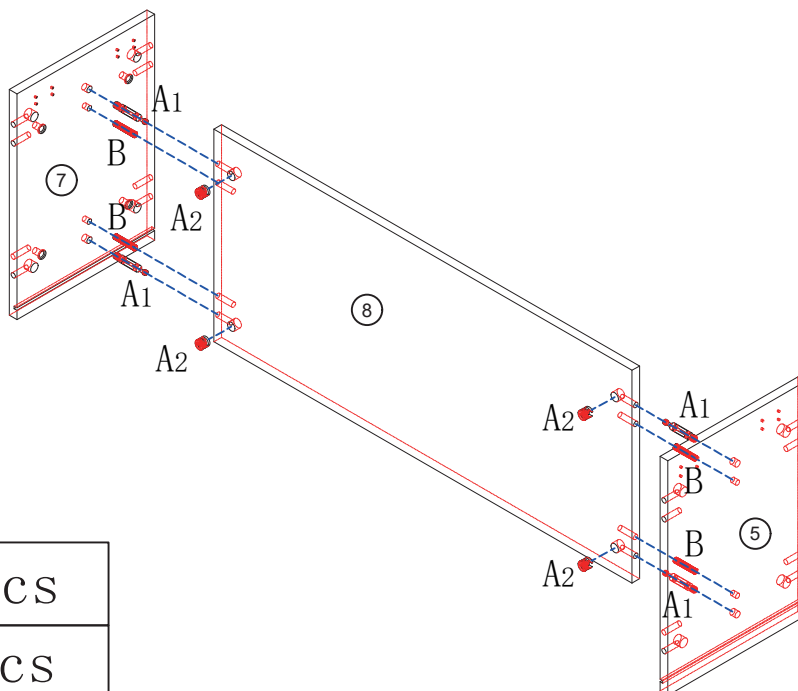

Schritt 2

Step 2



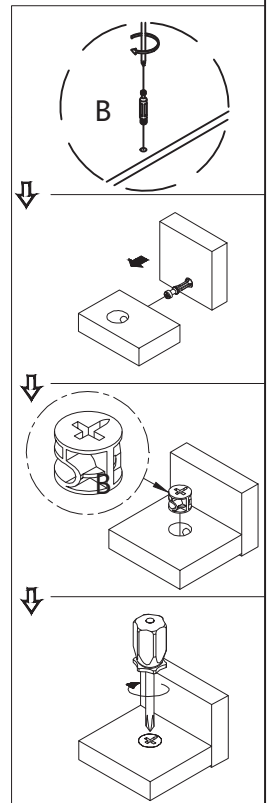

	A1x4pcs
	A2x4pcs
	Bx4pcs

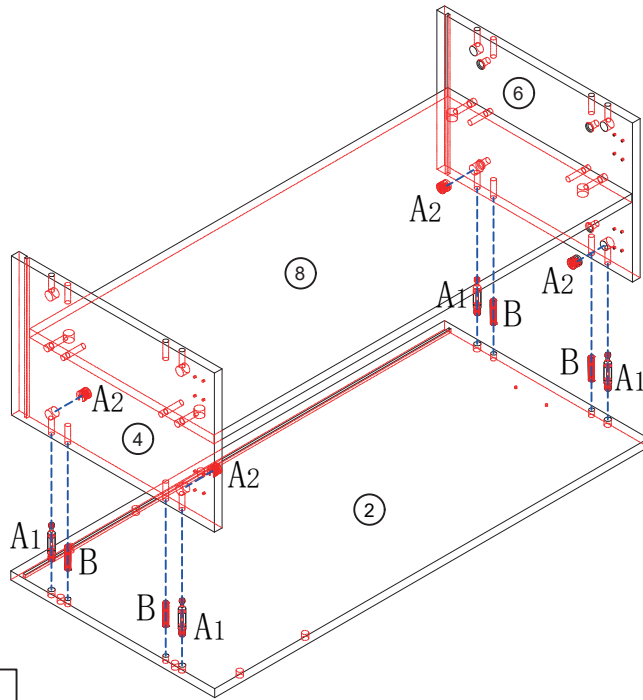

Schritt 3 Step 3



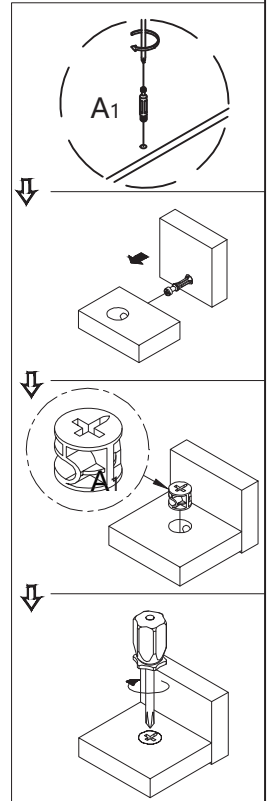

	A1x4pcs
	A2x4pcs
	Bx4pcs

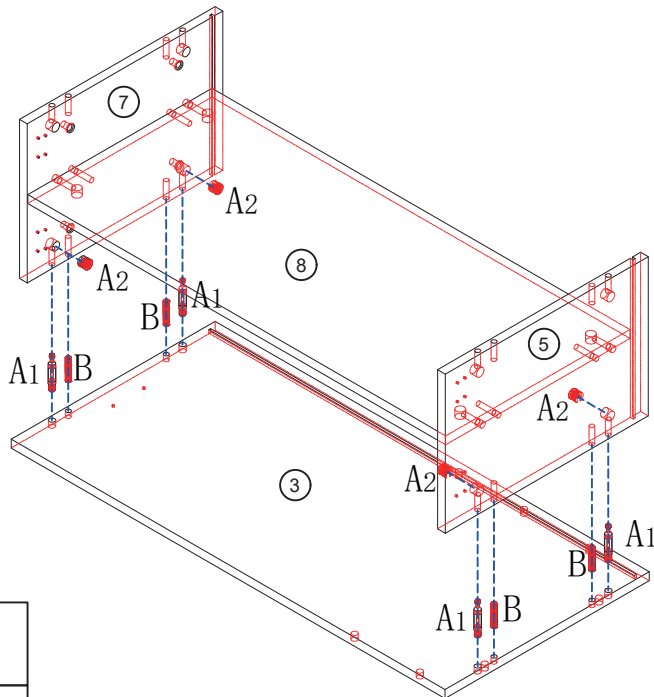

Schritt 4 Step 4



	A1x4pcs
	A2x4pcs
	Bx4pcs

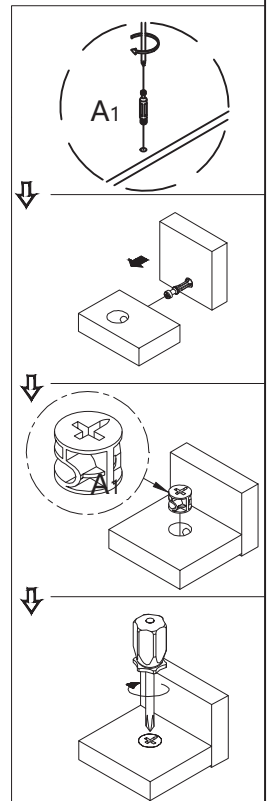

Schritt 5

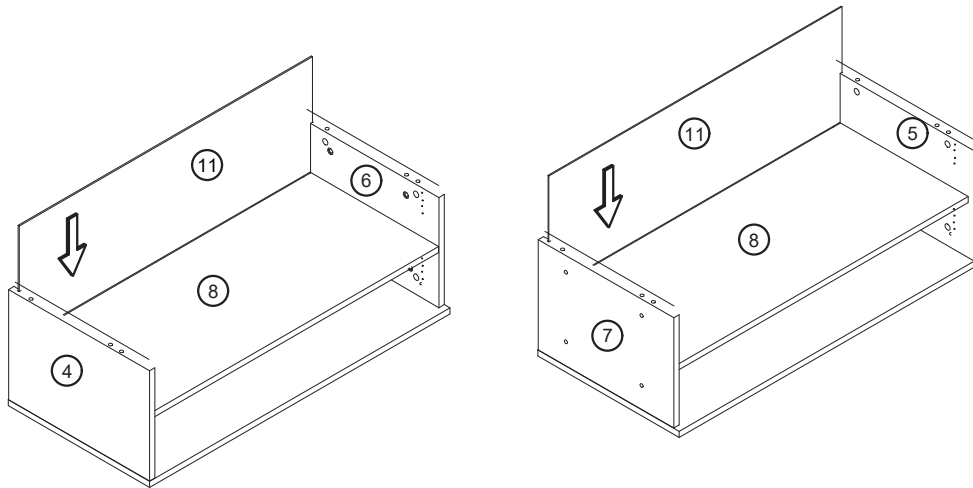

Step 5

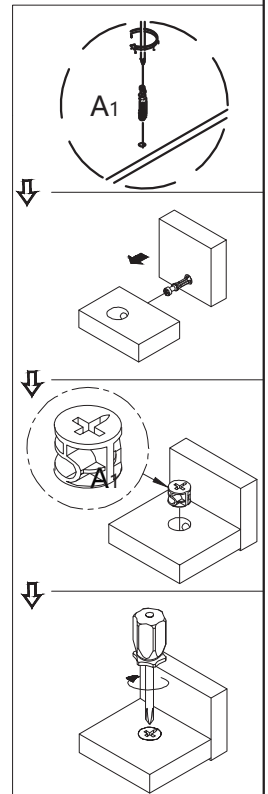
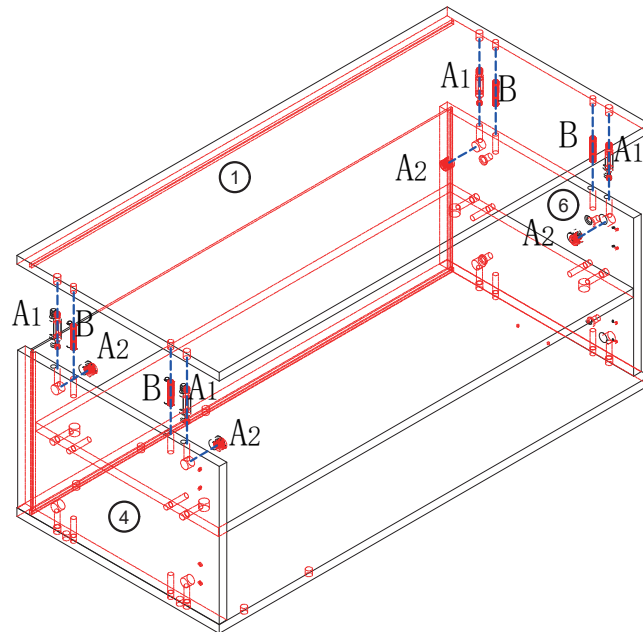

Schritt 6

Step 6





	A1x4pcs
	A2x4pcs
	Bx4pcs

Schritt 7

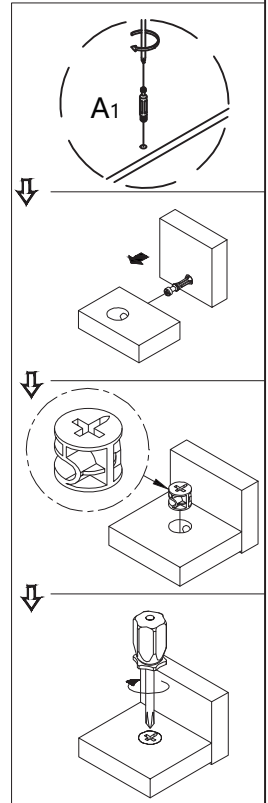
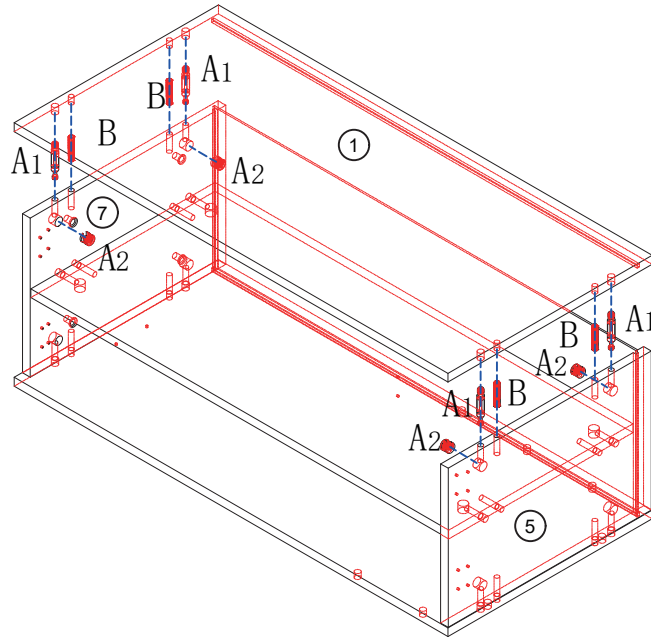
Step 7





	A1x4pcs
	A2x4pcs
	Bx4pcs

Schritt 8

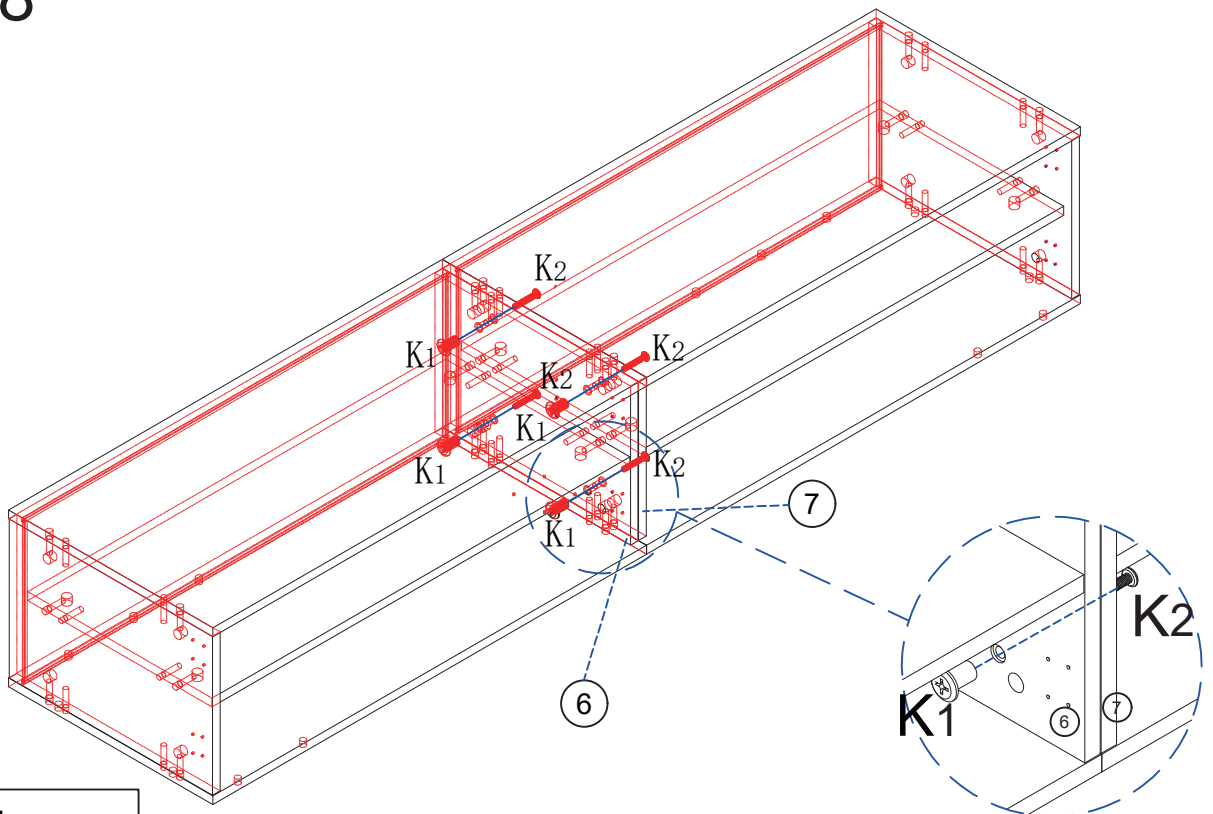
Step 8



	K1 x4pcs
	K2x4pcs

Schritt 9

Step 9

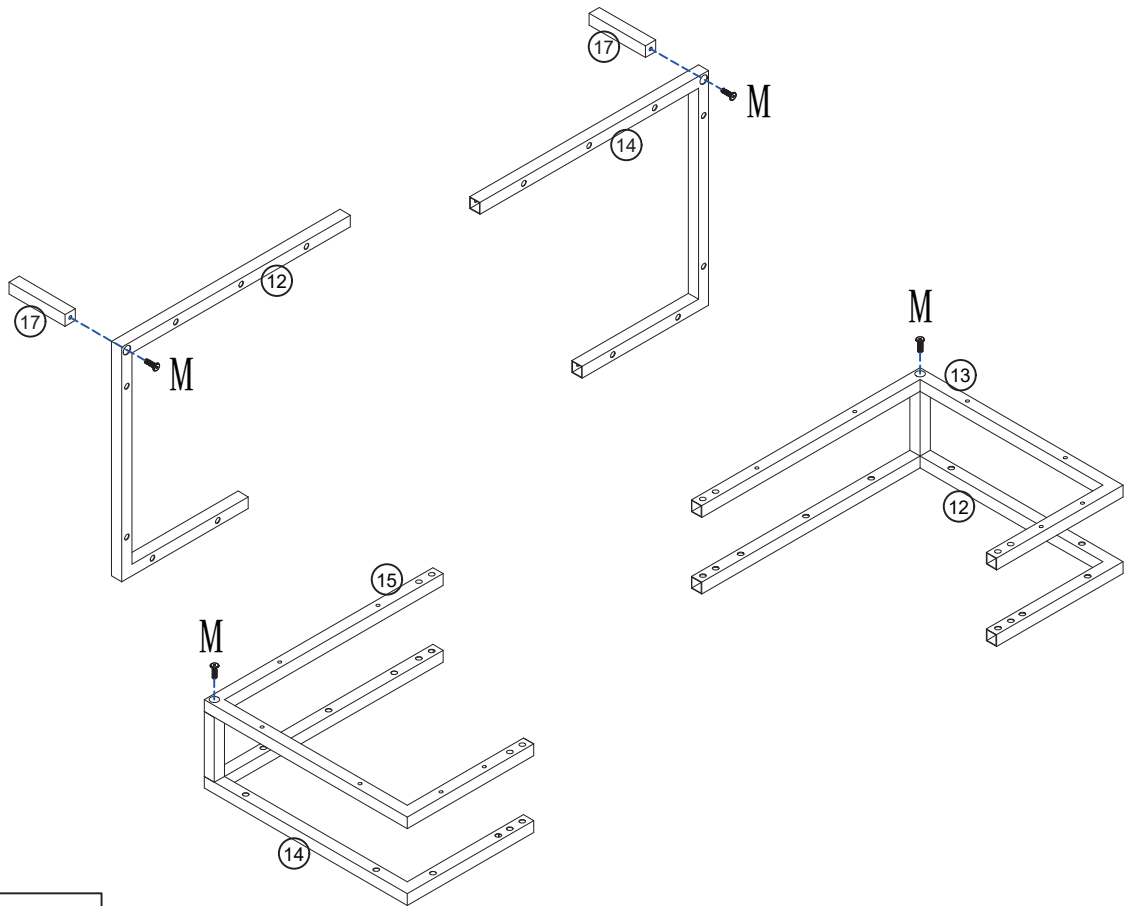

Mx4pcs

Schritt 10



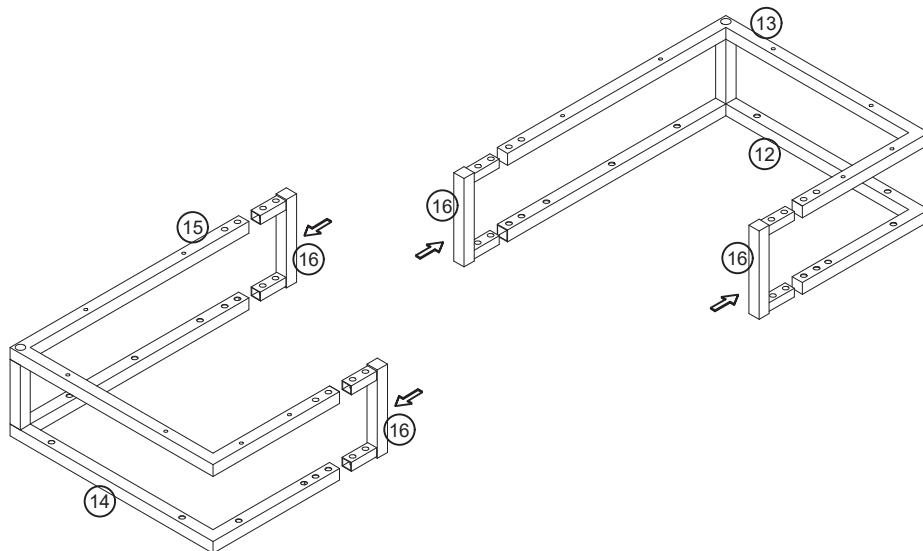

Step 10

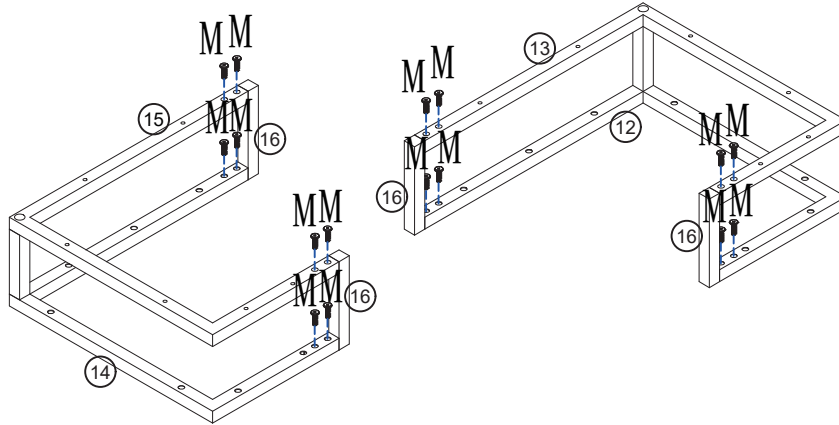

Schritt 11

Step 11





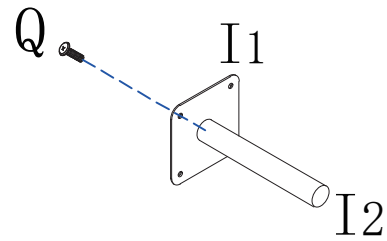

	Mx16pcs
	Qx1pcs
	I1x1pcs
	I2x1pcs

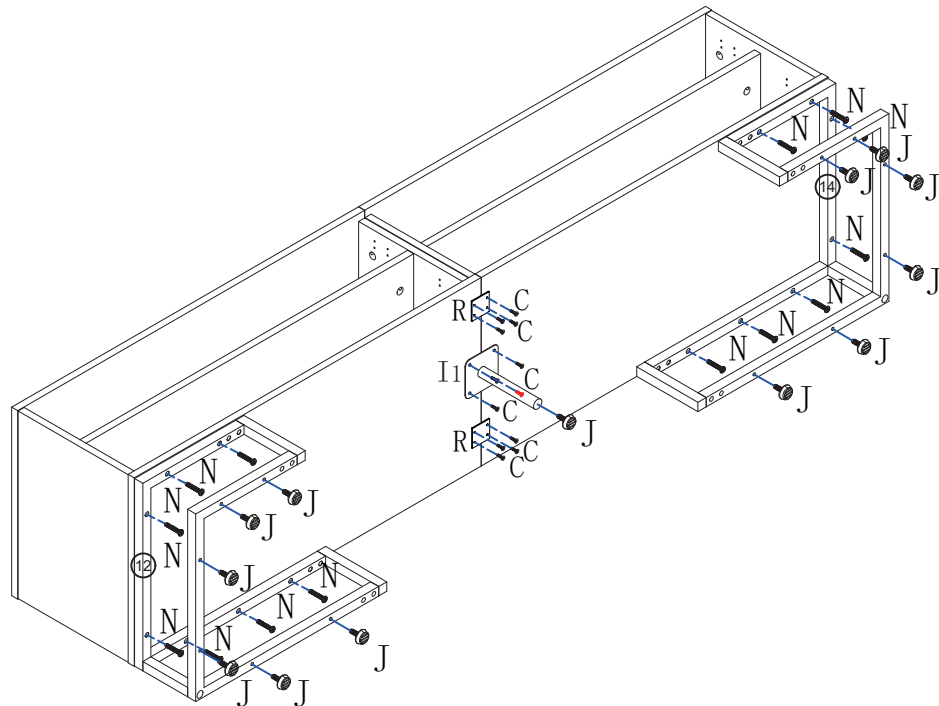

Schritt 12

Step 12





	Rx2pcs
	Cx12pcs
	Jx13pcs
	Nx14pcs

Schritt 13

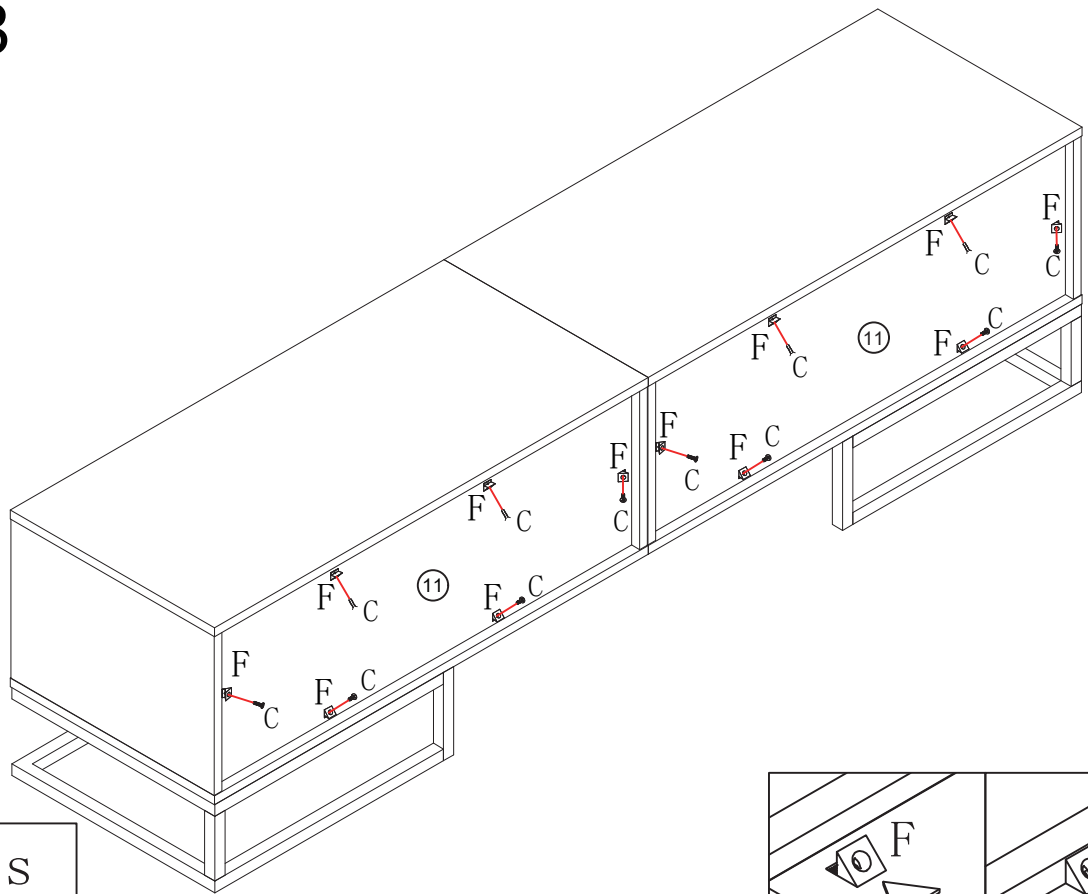
Step 13





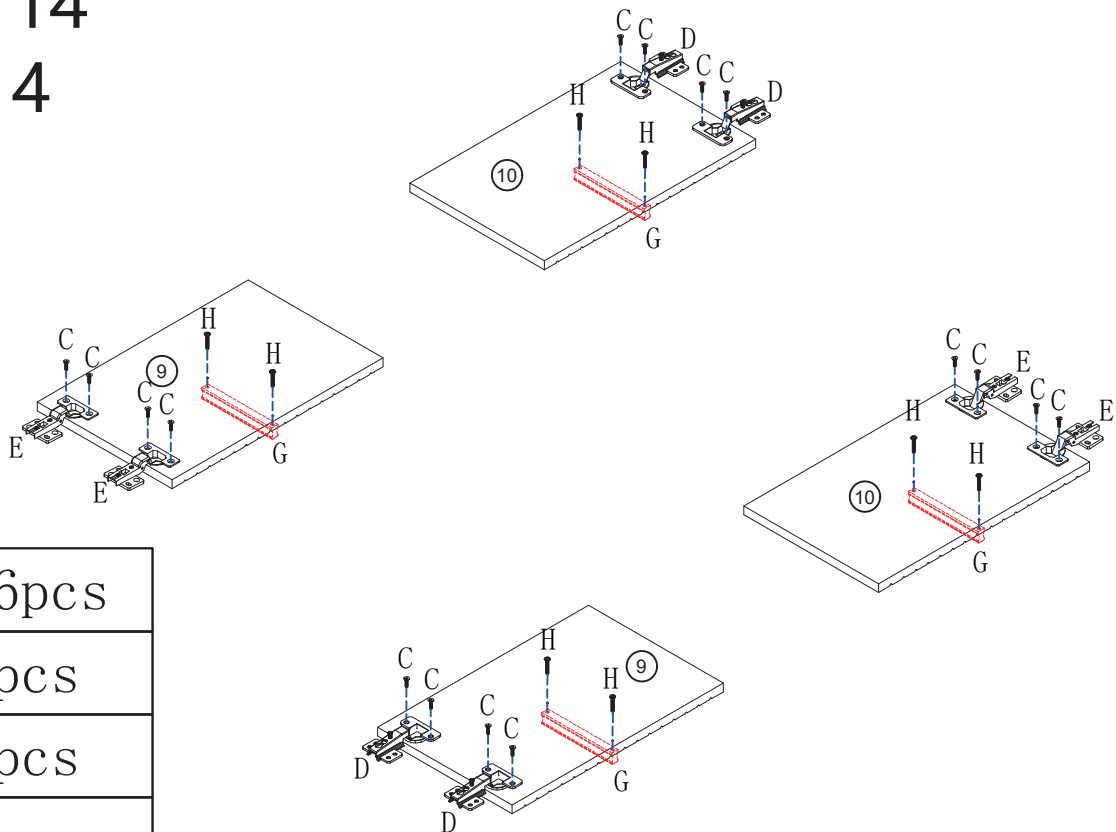

	Cx12pcs
	Fx12pcs

Schritt 14

Step 14



	Cx16pcs
	Ex4pcs
	Dx4pcs
	Gx4pcs
	Hx8pcs

Schritt 15

Step 15

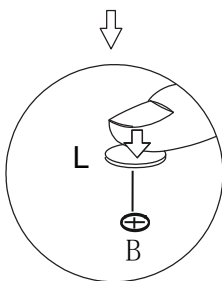
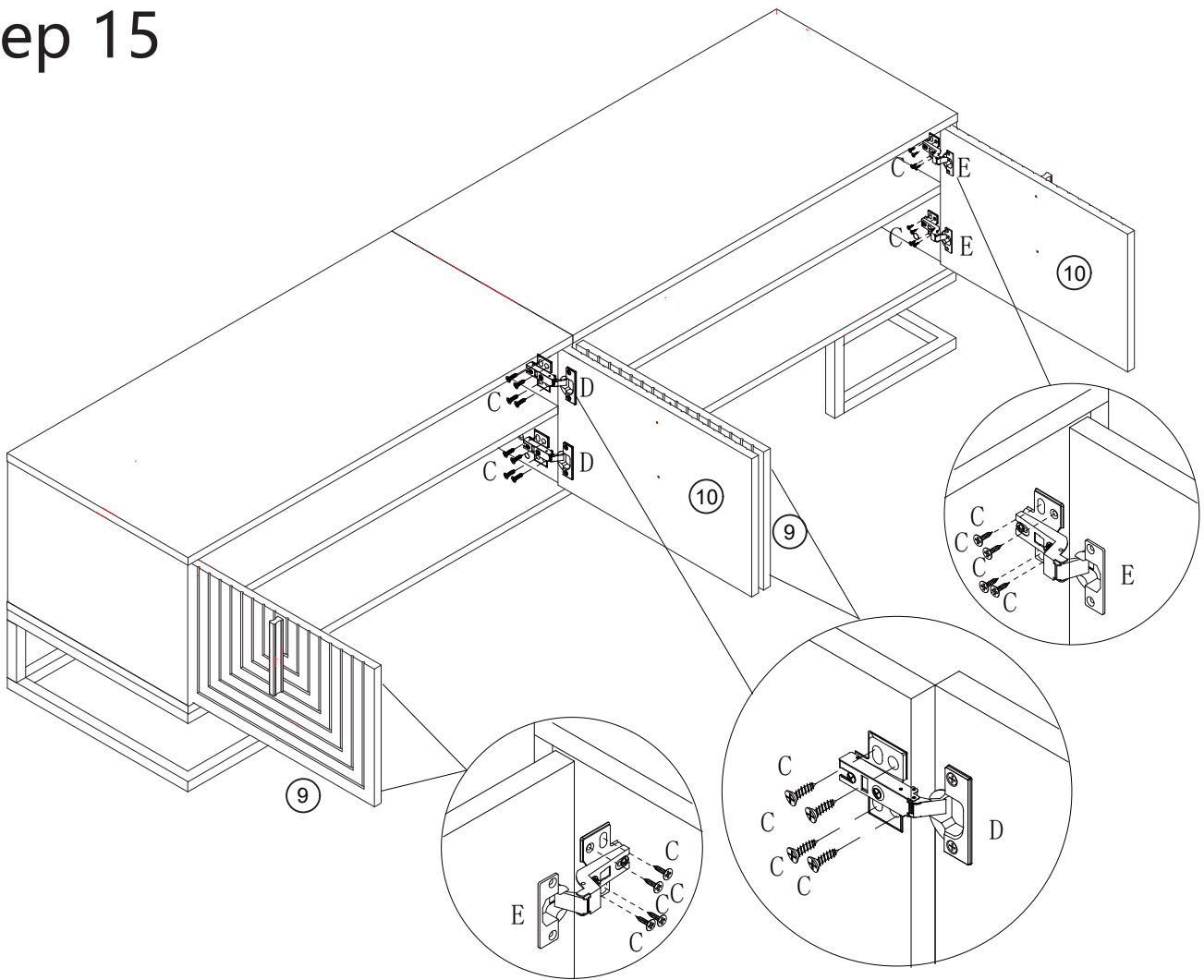

Note: It is forbidden to install the fixing hole screws first, otherwise it will lead to installation failure!

Remarque : Il est interdit d'installer d'abord les vis du trou de fixation, sinon cela entraînera un échec de l'installation !

Hinweis: Es ist verboten, zuerst die Befestigungslochschauben zu montieren, da dies sonst zu einem Installationsfehler führt!

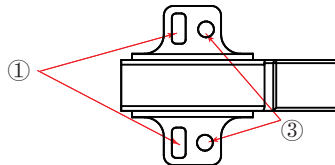



- ① Installez d'abord les vis du trou de réglage
- ② Mettez la porte dans la bonne position
- ③ Montieren Sie abschließend die Befestigungslochschauben

- ① Install the adjustment hole screws first
- ② Get the door in the right position
- ③ Finally, install the fixing hole screws

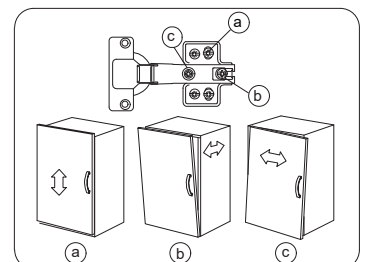
- ① Montieren Sie zuerst die Einstellochschauben
- ② Bringen Sie die Tür in die richtige Position
- ③ Enfin, installez les vis du trou de fixation





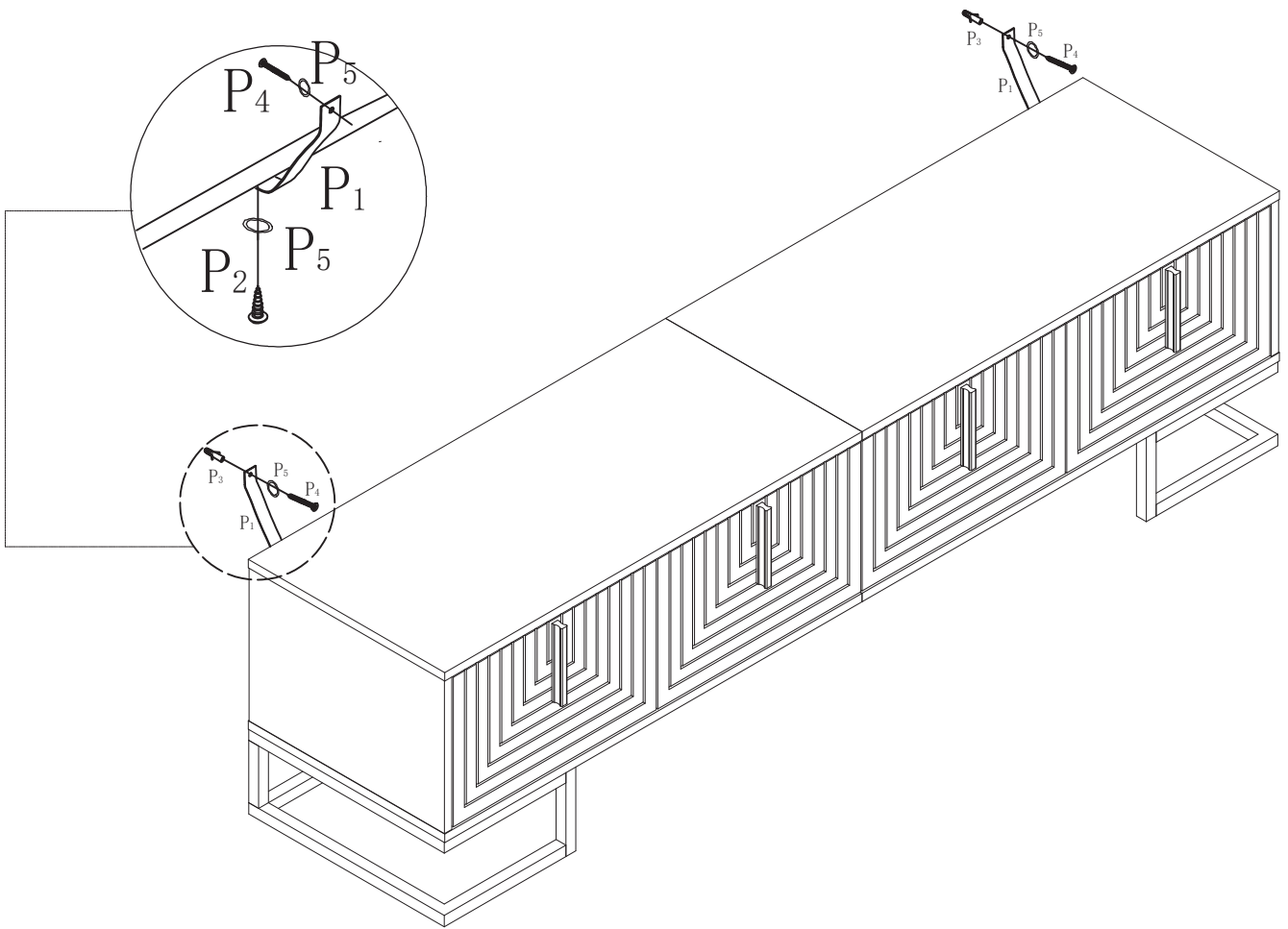

	Cx32pcs
	Lx24pcs

Schritt 16

Step 16



	P ₅ x4pcs
	P ₁ x2pcs
	P ₂ x2pcs
	P ₃ x2pcs
	P ₄ x2pcs

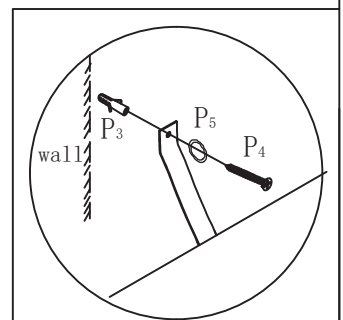

Schritt 17

Step 17

DE:ACHTUNG: Zur Sicherheit und Stabilität empfehlen wir Ihnen, die Kippsicherungszubehör an der Wand zu befestigen, um ein Umkippen, Verletzungen und Sachschäden zu verhindern.

UK:ATTENTION: For safety and stability, we suggest you have to secure the anti tip accessories to the wall to prevent tipping, injury, and property damage.

FR:ATTENTION : Pour la sécurité et la stabilité, nous vous recommandons de fixer les accessoires anti-basculement au mur afin d'éviter tout renversement, blessure et dommage matériel.

IT: ATTENZIONE: Per garantire sicurezza e stabilità, ti consigliamo di fissare gli accessori di sicurezza contro il ribaltamento alla parete, per prevenire ribaltamenti, lesioni e danni materiali.

ES:ATENCIÓN: Para garantizar seguridad y estabilidad, le recomendamos que fije los accesorios de seguridad contra el vuelco a la pared para prevenir vuelcos, lesiones y daños materiales.

NL: LET OP: Voor veiligheid en stabiliteit raden wij aan om de anti-kantelaccessoires aan de muur te bevestigen om kantelen, letsel en schade aan eigendommen te voorkomen.

SE: OBS: För säkerhet och stabilitet rekommenderar vi att du fäster anti-tipp-tillbehören på väggen för att förhindra att de tippar, skador och egendomsskador.

PL: UWAGA: Dla bezpieczeństwa i stabilności zalecamy przymocowanie akcesoriów antyprzewrócenia do ściany, aby zapobiec przewróceniu, urazom i uszkodzeniu mienia.