

Installationsanleitung Installation Instruction Instructions d'installation

**N623P194767/N623P194768
N623P307265/N623P307266**

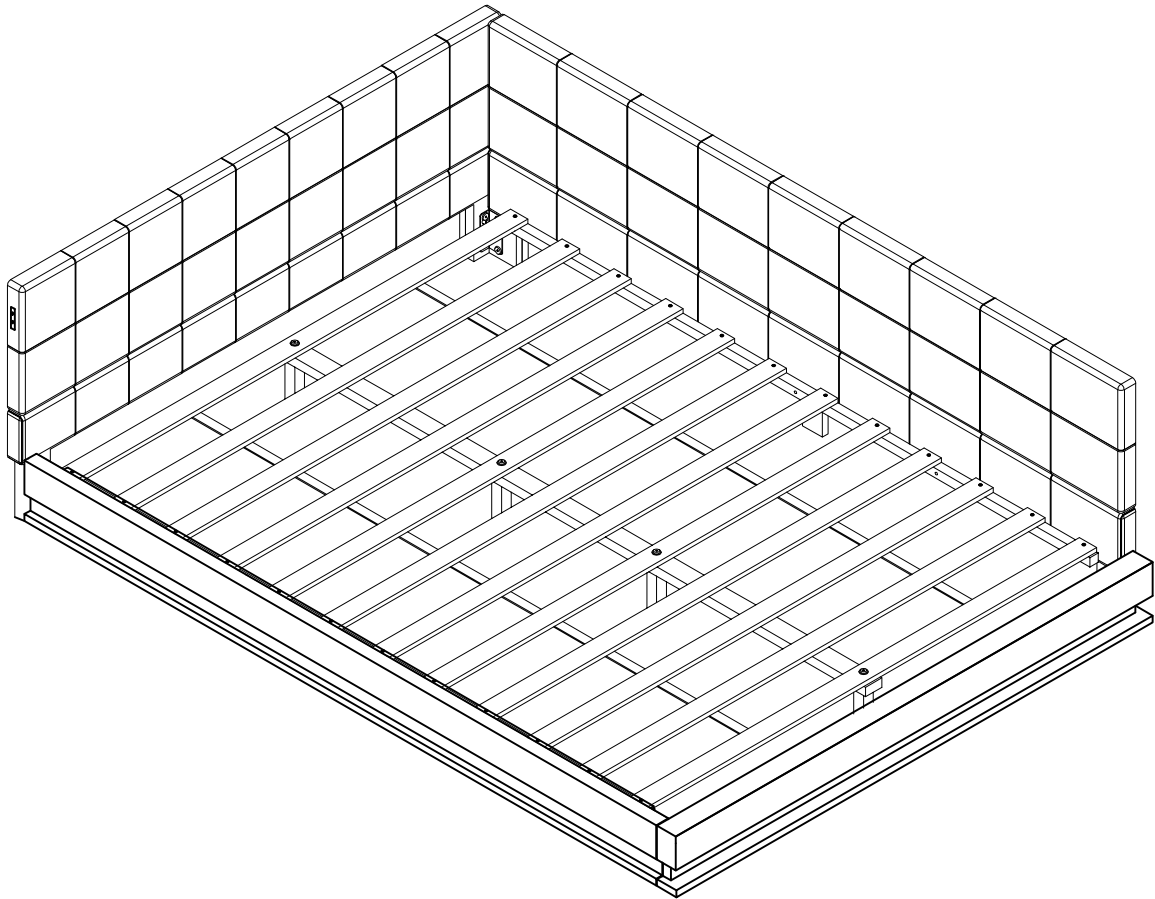

DE: Unser Produkt wird Ihnen in 2 Paketen geliefert. Die Lieferzeiten dieser 2 Pakete können abweichen, bitte haben Sie etwas Geduld und vielen Dank für Ihr Verständnis.

UK: Our product will be delivered to you in 2 packages. The delivery times of these 2 packages may differ, please be patient and thank you for your understanding.

FR: Notre produit vous sera livré en 2 colis. Les délais de livraison de ces 2 colis peuvent différer, soyez patient et merci pour votre compréhension.



DE:Vor dem Einbau die Schrauben in die Löcher stecken und festziehen, aber nicht bis 100%, 70% bis 80% anziehen reicht aus. Schließlich, nachdem alle Schrauben installiert sind, ziehen Sie alle Schrauben auf 100%.Wenn Sie auf diese Probleme stoßen, wie z. B. Fehlausrichtung der Löcher oder Unfähigkeit, bestimmte Teile zu installieren, überprüfen Sie bitte, ob die Schrauben korrekt verwendet werden und passen Sie die Dichtigkeit der Schrauben an.

UK:Before installation, insert the screws into the holes and tighten them, but do not tighten them to 100%, 70% to 80% is sufficient. Finally, after all screws are installed, tighten all screws to 100%.If you encounter these issues, such as if the holes cannot be aligned or some parts cannot be installed, please check if the screws are used correctly and adjust the tightness of the screws.

FR:Insérer la vis dans le trou avant la fin de l'assemblage, serrer la vis, mais ne pas serrer à 100%, 70% ~ 80% est correct. Enfin, une fois que toutes les vis sont bien serrées, toutes les vis sont serrées à 100%.Si vous rencontrez ces problèmes, par exemple si les trous ne sont pas alignés ou si certaines pièces ne peuvent pas être montées, vérifiez que les vis sont utilisées correctement et Ajustez leur serrage.

English

IMPORTANT ! KEEP FOR FUTURE REFERENCE : READ CAREFULLY

- To be assembled by an adult. Assembly must be checked by an adult before use
- WARNING ! Keep all screws, small parts and plastic bags out of the reach of children
- Properly identify all parts before assembling
- Never use your item if any of its parts are broken or missing
- Should any problems arise, please contact our After Sales Service
- Manufacturer's instructions shall be followed at all times
- Care: Clean with a soft, dry cloth. In case of larger stains, carefully rub with a slightly damp, non-abrasive sponge
- Avoid the risk of fire by not placing furniture near sources of ignition or hot items
- Do not jump on the bed

Deutsch

WICHTIG ! ZUM SPÄTEREN NACHSCHLAGEN AUFBEWAHREN: SORGFÄLTIG LESEN

- Muss von einem Erwachsenen zusammengebaut werden. Der Zusammenbau muss vor dem Gebrauch von einem Erwachsenen **überprüft** werden
- WARNUNG! Bewahren Sie alle Schrauben, Kleinteile und Plastikbeutel **außerhalb** der Reichweite von Kindern auf
- Kennzeichnen Sie vor dem Zusammenbau alle Teile richtig
- Benutzen Sie Ihren Artikel niemals, wenn Teile gebrochen sind oder fehlen
- Sollten Probleme auftreten, wenden Sie sich bitte an unseren Kundendienst
- Die Anweisungen des Herstellers sind stets zu befolgen
- Pflege: Mit einem weichen, trockenen Tuch reinigen. Bei **größer**en Flecken vorsichtig mit einem leicht feuchten, nicht scheuernden Schwamm abreiben. nicht scheuernden Schwamm
- Vermeiden Sie die Gefahr eines Brandes, indem Sie die **Möbel** nicht in der **Nähe** von **Zündquellen** oder **heißen** Gegenständen aufstellen
- Nicht auf das Bett springen

Français

IMPORTANT ! CONSERVER POUR RÉFÉRENCE ULTÉRIEURE : LIRE ATTENTIVEMENT

- Le montage doit **être** effectué par un adulte. Le montage doit **être vérifié** par un adulte avant Utilisation
- ATTENTION ! Tenir les vis, les petites pièces et les sachets en plastique hors de portée des enfants
- Identifiez correctement toutes les **pièces** avant de les assembler
- N'utilisez jamais votre article si l'une de ses **pièces** est cassée ou manquante
- En cas de **problème**, veuillez contacter notre service après-vente
- Les instructions du fabricant doivent **être respectées à** tout moment
- Entretien : nettoyer avec un chiffon doux et sec. En cas de taches plus importantes, frotter soigneusement avec une **éponge** non abrasive **légèrement** humide. **légèrement** humide et non Abrasive
- Évitez les risques d'incendie en ne **plaçant** pas les meubles **à proximité** de sources d'inflammation ou d'objets chauds
- Ne pas sauter sur le lit

Italiano

IMPORTANTE! CONSERVARE PER RIFERIMENTO FUTURO: LEGGERE ATTENTAMENTE

- Deve essere assemblato da un adulto. L'assemblaggio deve essere controllato da un adulto prima dell'uso
- **ATTENZIONE!** Tenere tutte le viti, le piccole parti e i sacchetti di plastica fuori dalla portata dei bambini
- Identificare correttamente tutte le parti prima dell'assemblaggio
- Non utilizzare mai l'articolo se alcune parti sono rotte o mancanti
- In caso di problemi, si prega di contattare il nostro Servizio Post Vendita
- Le istruzioni del produttore devono essere sempre seguite
- Cura: Pulire con un panno morbido e asciutto. In caso di macchie più estese, strofinare accuratamente con una spugna leggermente umida e nonspugna leggermente umida e non abrasiva
- Evitare il rischio di incendio, non collocando i mobili vicino a fonti di accensione o a oggetti caldi
- Non saltare sul letto

Español

¡IMPORTANTE ! CONSERVELO PARA FUTURAS CONSULTAS: LEA ATENTAMENTE

- Debe ser montado por un adulto. El montaje debe ser comprobado por un adulto antes del uso
- **ADVERTENCIA** Mantenga todos los tornillos, piezas pequeñas y bolsas de plástico fuera del alcance de los niños.
- Identifique correctamente todas las piezas antes de montarlas
- Nunca utilice su artículo si alguna de sus piezas está rota o falta
- Si surge algún problema, póngase en contacto con nuestro Servicio Postventa
- Las instrucciones del fabricante deben seguirse en todo momento
- Cuidado: Limpiar con un paño suave y seco. En caso de manchas más grandes, frote cuidadosamente con una esponja no abrasiva ligeramente humedecida.
- Evite el riesgo de incendio no colocando los muebles cerca de fuentes de ignición u objetos calientes.
- No saltar sobre la cama.

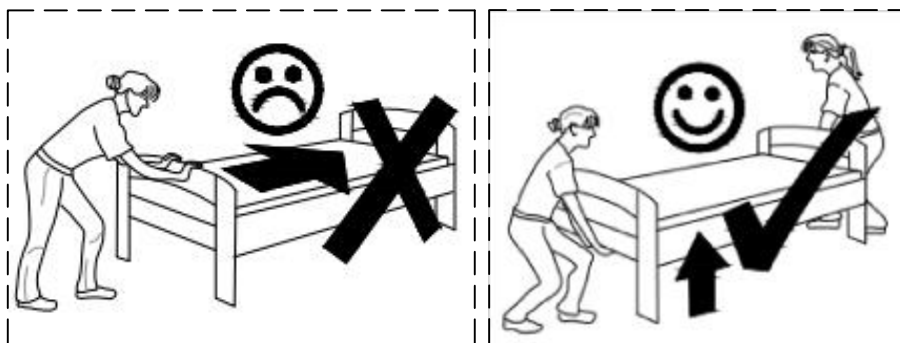

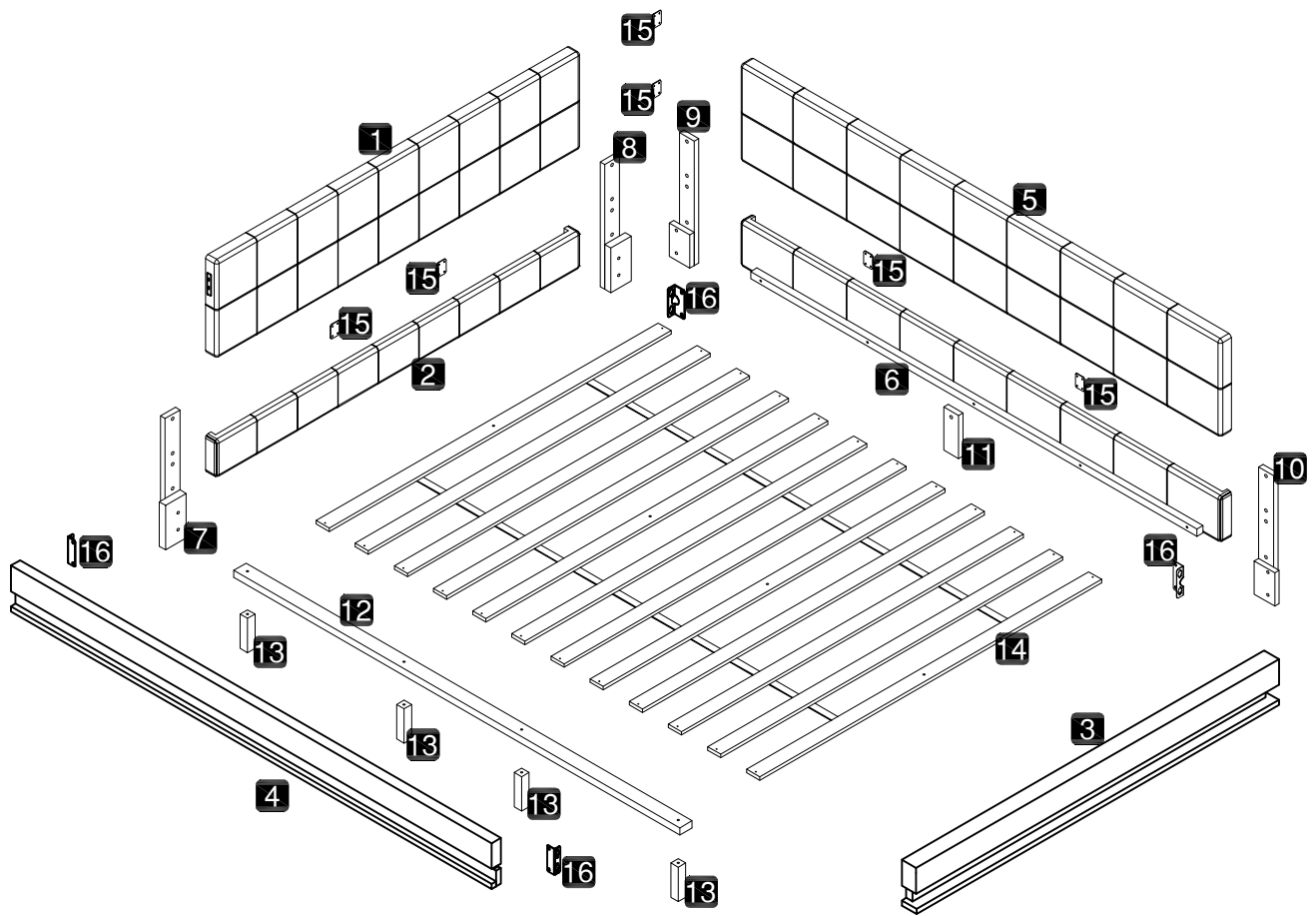



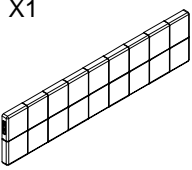
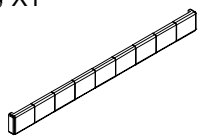
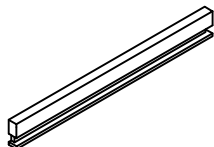
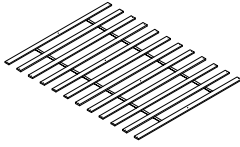

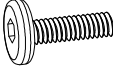

Part List-Teileliste-Liste des pièces N623P194767/N623P307265

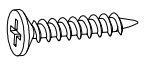
<p>1 X1</p> 	<p>2 X1</p> 	<p>3 X1</p> 	<p>14 X1</p> 
--	--	--	--

Hardware List-Hardware-Liste-Liste du matériel N623P194768/N623P307266

<p>A</p>  <p>M8x20mm) X16</p>	<p>B</p>  <p>(M8x40mm) X17</p>	<p>C</p>  <p>(M6x55mm) X4</p>	<p>D</p>  <p>(4.0x28mm) X24</p>	<p>E</p>  <p>(4.0x20mm) X24</p>
<p>F X21</p> 	<p>L X1</p> 			

Part List-Teileliste-Liste des pièces N623P194768/N263P307266

4 X1 	5 X1 	6 X1 	7 X1 	8 X1
9 X1 	10 X1 	11 X1 	12 X1 	13 X4
15 x6 	16 X4 	G X1 	W X1 	V X1
T X1 				

A 	B
M8x20mm	M8x40mm

DE:Bitte beachten Sie, dass die Formen der Schrauben A und B ähnlich sind. Bitte installieren Sie entsprechend der Anleitung und unterscheiden Sie sie!

UK:Please note that the shapes of screws A and B are similar. Please install according to the instructions and distinguish them!

FR:Notez que les vis A et B ont des formes similaires. Veuillez les installer en suivant les instructions pour les séparer!

D 	E
(4.0x28mm)	(4.0x20mm)

DE:Bitte beachten Sie, dass die Formen der Schrauben D und E ähnlich sind. Bitte installieren Sie entsprechend der Anleitung und unterscheiden Sie sie!

UK:Please note that the shapes of screws D und E are similar. Please install according to the instructions and distinguish them!

FR:Notez que les vis D und E ont des formes similaires. Veuillez les installer en suivant les instructions pour les séparer!

1

L x1



F x8



E x8



4.0x20mm

B x8

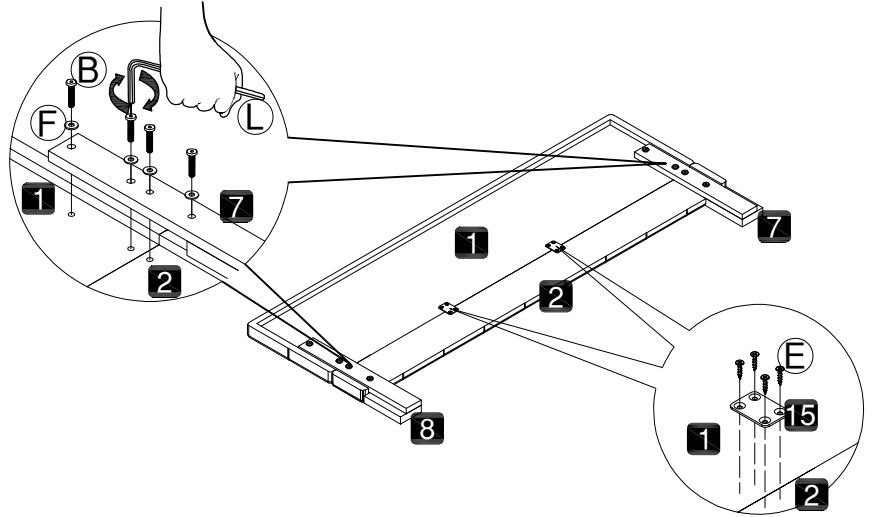
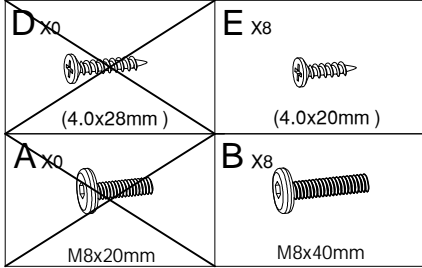

M8x40mm

**2**

L x1



F x9



E x8



4.0x20mm

B x9

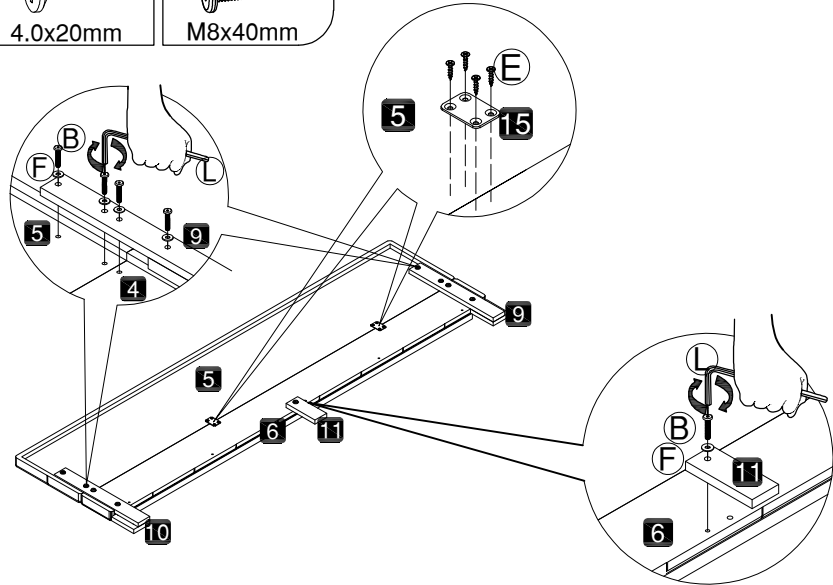
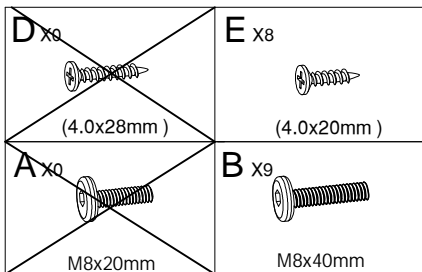

M8x40mm

**3**

L x1



A x8



M8x20mm

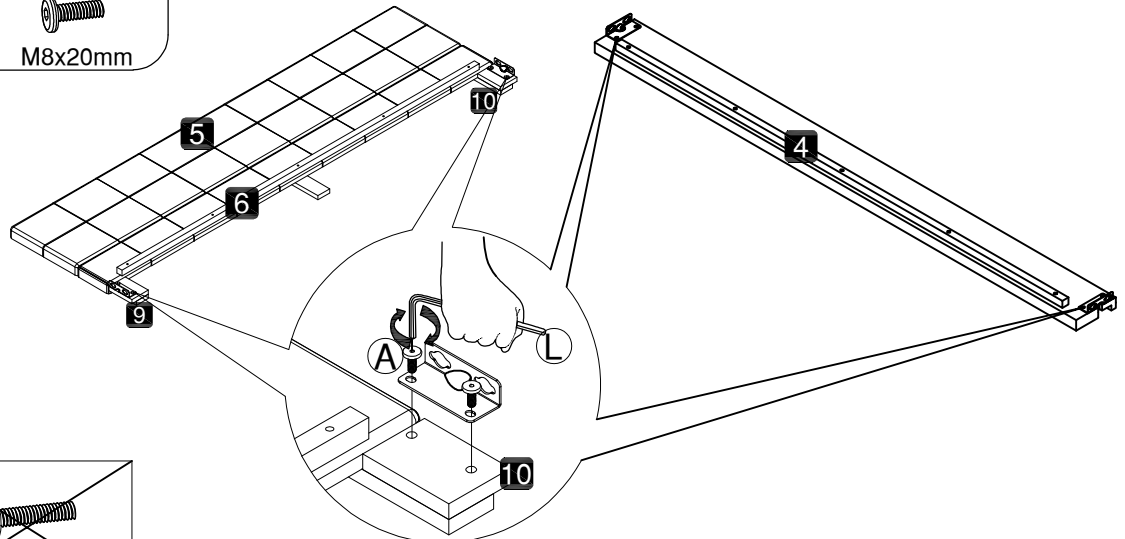
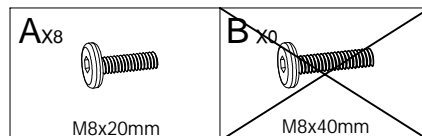

4

L × 1



E × 8



4.0x20mm

A × 8

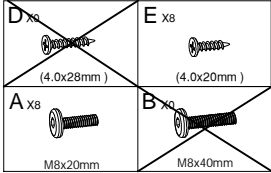
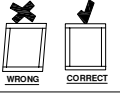
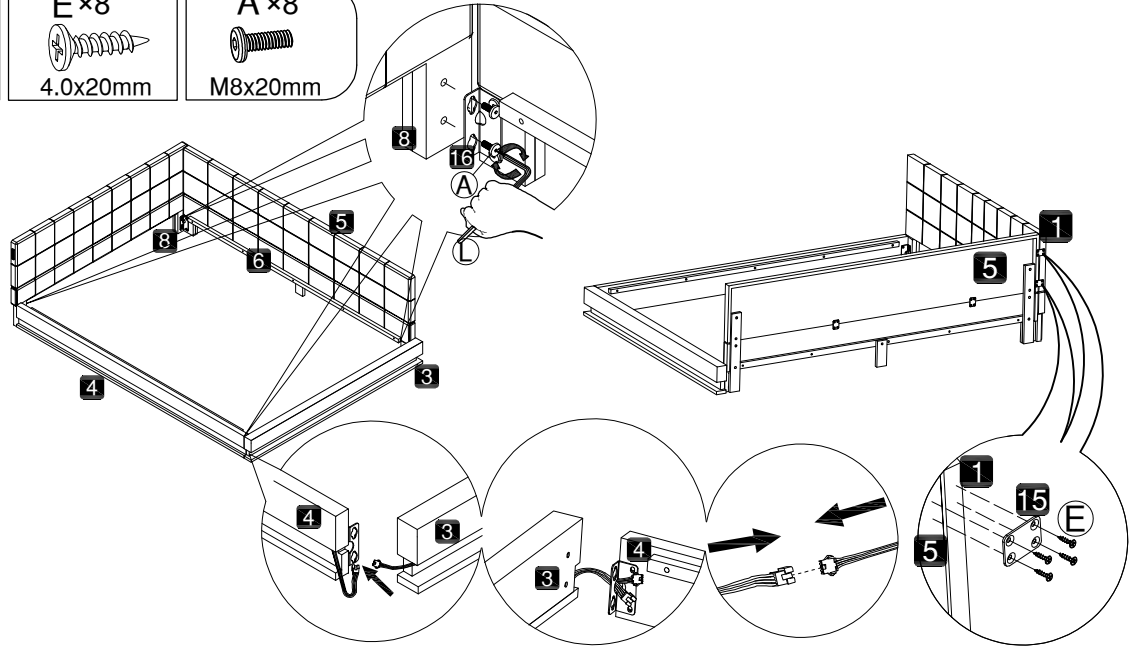

M8x20mm

**5**

L × 1



F × 4



C × 4

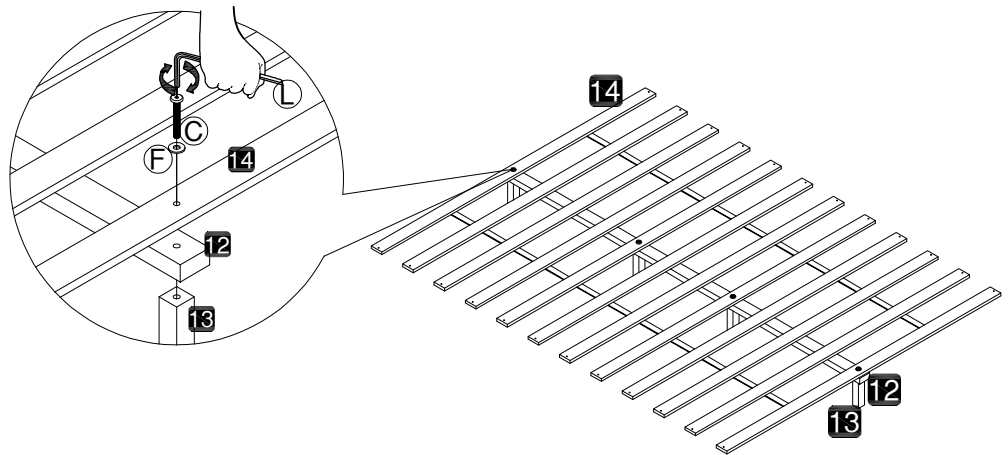

M6x55mm

**6**

L × 1



D × 24



4.0x28mm

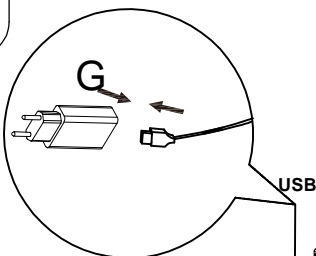

USB

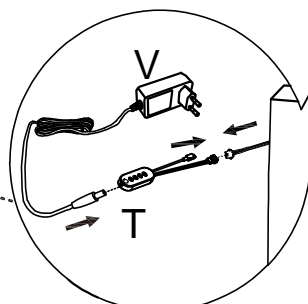
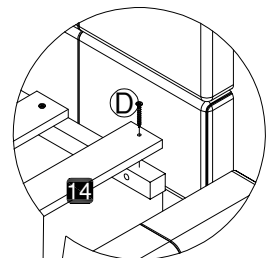
LED light
(LED-Licht)LED light
(LED-Licht)

D × 24



(4.0x28mm)

E × 0



(4.0x20mm)

LED light

If you can't let the lights work successfully, please check the following:

1. Please check the direction of the connect, try it in the opposite direction, according to the following picture.
2. Please check if the positive and negative directions of the battery are installed correctly.
3. If one of the colors is not bright, please check whether the four wires in the plug are skewed, and move the main line to make the four wires flush.

(LED-Licht)

(Wenn Sie die Lampe nicht erfolgreich funktionieren lassen, überprüfen Sie bitte Folgendes:

1. Bitte überprüfen Sie die Verbindungsrichtung und versuchen Sie in der entgegengesetzten Richtung gemäß der Abbildung unten.
2. Bitte überprüfen Sie, ob die positive und negative Richtung der Batterie korrekt installiert sind.
3. Wenn eine der Farben nicht hell ist, überprüfen Sie bitte, ob die vier Drähte im Stecker schief sind, und bewegen Sie die Hauptleitung, um die vier Drähte bündig zu machen.)

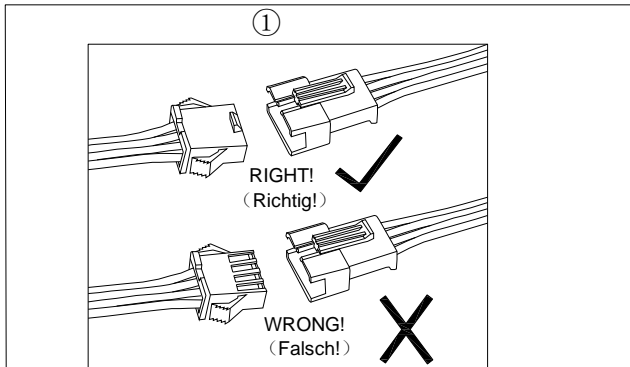

Deutsch:
"Sie können den QR-Code scannen, um die App herunterzuladen und die LED-Leiste per Smartphone zu steuern."
English:
"You can scan the QR code to download the app and control the LED light strip via your smartphone."
Français:
"Vous pouvez scanner le code QR pour télécharger l'application et contrôler la bande lumineuse LED via votre téléphone portable."
Español:
"Puede escanear el código QR para descargar la aplicación y controlar la tira de luces LED mediante su teléfono móvil."
Italiano:
"Puoi scansionare il codice QR per scaricare l'app e controllare la striscia LED tramite il tuo smartphone."

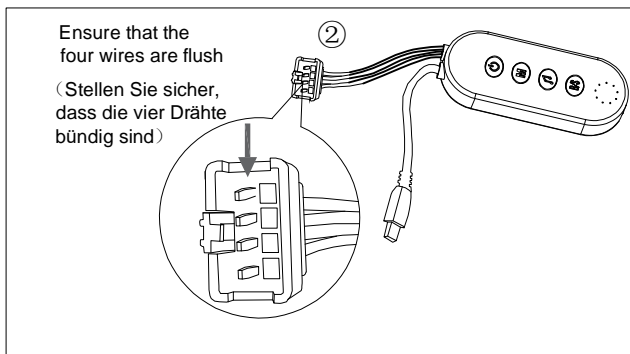

Operation Instructions of Controller (Betriebsanleitung des Reglers)

Technical parameter : (Technische parameter:)

<ul style="list-style-type: none"> • working temperature : -20-60°C • Betriebstemperatur : -20-60°C) 	<ul style="list-style-type: none"> • output : 3CH/ RGB • Ausgang: 3CH/ RGB)
<ul style="list-style-type: none"> • working voltage : DC5-24V (• Arbeitsspannung: DC5-24V) 	<ul style="list-style-type: none"> • receiving range : <10 meters (• Akzeptanzbereich: <10 meters)
<ul style="list-style-type: none"> • product power : 5V=30W 12V=72W 24V=144W (• Produktleistung : 5V=30W 12V=72W 24V=144W) 	

Introduction to remote control button function : (Einführung in die Funktionen die Fernbedienung)

Button (Taste)		Function (Funktion)	
		ON / OFF (Ein / Aus)	Turn on / off the LED controller (LED-Controller ein-/ausschalten)
		Speed / brightness+ Speed / brightness- (Geschwindigkeit/Helligkeit+ Geschwindigkeit/Helligkeit-)	Adjust brightness in static mode . Adjust speed in flash mode . (Helligkeit im statischen Modus anpassen. Geschwindigkeit im Blitzmodus einstellen.)
		music (musik)	5 music modes , can switch (5Musikmodi , die geschaltet werden können)
		16 static color keys (16 statische Farbschlüssel)	16 fixed color keys are used to set the corresponding static color (Brightness adjustable) [Verwenden Sie 16-feste Farbtasten, um die entsprechende statische Farbe einzustellen (einstellbare Helligkeit)]
		FLASH (BLITZ)	Three color jump (Adjustable speed) [Tri Farbsprung (einstellbare Geschwindigkeit)]
		STROBE (FREQUENZLICHT)	Three color gradient (Adjustable speed) [Tri Farbverlauf (einstellbare Geschwindigkeit)]
		FADE (VERLAUF)	Seven color gradient (Adjustable speed) [Bunte Steigung (einstellbare Geschwindigkeit)]
		SMOOTH (GLATT)	Seven color jump (Adjustable speed) [Bunter Sprung (einstellbare Geschwindigkeit)]

III. Panel specification and connecting drawing as follows: (Plattenspezifikation und Anschlusszeichnung wie folgt)

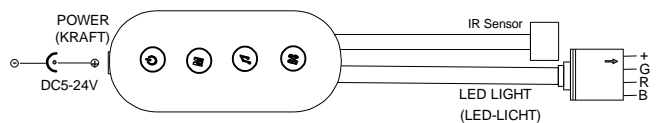

DE: Wenn Sie die Lichter nicht erfolgreich arbeiten lassen können, überprüfen Sie bitte die Folgendes:

1. Bitte überprüfen Sie die Fernbedienung. Sie müssen die Fernbedienung abreißen Plastikseptum vor Gebrauch.
2. Lassen Sie die Fernbedienung nicht zu weit vom Empfänger entfernt sein. Es gibt kein Hindernis zwischen ihnen.
3. Bitte beachten Sie, dass die Fernbedienung für den Transport keine Batterien enthält. Das Batteriemodell lautet: **Zinc-Carbon AAA Battery(R03)-1.5V. Setzen Sie die Batterien entsprechend der "+" (Plus) und "-" (Minus) Kennzeichnungen im Batteriefach ein.**

FR: Si vous ne parvenez pas à faire fonctionner les lumières correctement, veuillez vérifier les points suivants?:

1. Veuillez vérifier la télécommande. Vous devez retirer le septum en plastique de la télécommande avant utilisation.
2. Ne laissez pas la télécommande être trop éloignée du récepteur. Il n'y a aucun obstacle entre eux.
3. Veuillez noter que la télécommande ne contient pas de piles pour le transport. Le modèle de batterie est?: **Zinc-Carbon AAA Battery(R03)-1.5V. Insérez les piles en respectant les marquages "+" (positif) et "-" (négatif) à l'intérieur du compartiment.**

UK: If you can't make the lights work successfully, please check the following:

1. Please check the remote control. You need to tear off the remote plastic septum before use.
2. Don't let the remote control be too far from the receiver. There is no obstacle between them.
3. Please note that the remote control does not contain batteries for transportation. The battery model is: **Zinc-Carbon AAA Battery(R03)-1.5V. Insert batteries according to "+" (positive) and "-" (negative) markings inside the compartment.**

IT: Se non riesci a far funzionare le luci correttamente, ti preghiamo di controllare quanto segue:

1. Controlla il telecomando. Devi rimuovere il foglio di plastica protettivo dal telecomando prima dell'uso.
2. Non allontanare il telecomando troppo dal ricevitore. Assicurati che non ci siano ostacoli tra di essi.
3. Si prega di notare che il telecomando non contiene batterie per il trasporto. Il modello di batteria è: **Zinc-Carbon AAA Battery(R03)-1.5V. Inserire le batterie secondo le indicazioni "+" (positivo) e "-" (negativo) presenti all'interno del vano.**

ES: Si no puedes hacer funcionar las luces correctamente, por favor, revisa lo siguiente:

1. Verifica el control remoto. Debes quitar la película plástica protectora del control remoto antes de usarlo.
2. No alejes el control remoto demasiado del receptor. Asegúrate de que no haya obstáculos entre ellos.
3. Ten en cuenta que el control remoto no contiene baterías para el transporte. El modelo de la batería es: **Zinc-Carbon AAA Battery(R03)-1.5V. Inserte las pilas según las marcas "+" (positivo) y "-" (negativo) dentro del compartimento.**

NL: Als u de lichten niet succesvol kunt laten werken, controleer dan het volgende:

1. Controleer de afstandsbediening. U moet de plastic beschermfolie van de afstandsbediening verwijderen voordat u deze gebruikt.
2. Laat de afstandsbediening niet te ver van de ontvanger afstaan. Er mogen geen obstakels tussen hen in staan.
3. Houd er rekening mee dat de afstandsbediening geen batterijen bevat voor transport. Het batterijmodel is: **Zinc-Carbon AAA Battery(R03)-1.5V. Plaats de batterijen volgens de "+" (positief) en "-" (negatief) markeringen in het batterijvak.**

SE: Om du inte kan få lamporna att fungera korrekt, vänligen kontrollera följande:

1. Kontrollera fjärrkontrollen. Du måste ta bort den plastskyddade septum innan du använder den. 2. Låt inte fjärrkontrollen vara för långt från mottagaren. Det får inte finnas några hinder mellan dem.
3. Observera att fjärrkontrollen inte innehåller batterier för transport. Batterimodellen är: **Zinc-Carbon AAA Battery(R03)-1.5V. Sätt in batterierna enligt "+" (plus) och "-" (minus) märkningarna i batterifacket**

PL: Je li nie mo esz prawidłowo uruchomić światła, sprawdź poniżej:

1. Sprawdź pilot. Należy zdjąć plastikową osłonę z pilota przed użyciem.
2. Nie trzymaj pilota zbyt daleko od odbiornika. Pomiędzy nimi nie może być przeszkód.
3. Zwróć uwagę, że pilot nie zawiera baterii do transportu. Model baterii to: **Zinc-Carbon AAA Battery (R03) -1.5V. Włóż baterie zgodnie z oznaczeniami "+" (plus) i "-" (minus) wewnątrz przedziału.**

NOTE: The battery in the remote control requires you to purchase and install it yourself. Model: Zinc-Carbon AAA Battery(R03)-1.5V. Insert batteries according to "+" (positive) and "-"(negative) markings inside the compartment. Example as follows:

①



②



③



④



⑤

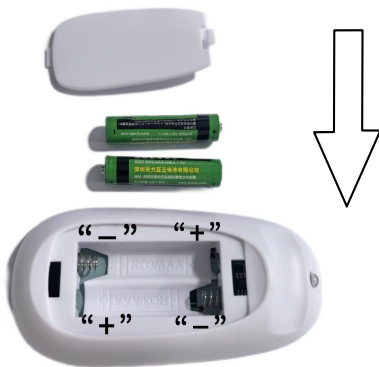

⑥



Modell : Zinc-Carbon AAA Battery(R03) -1.5V.

⑦

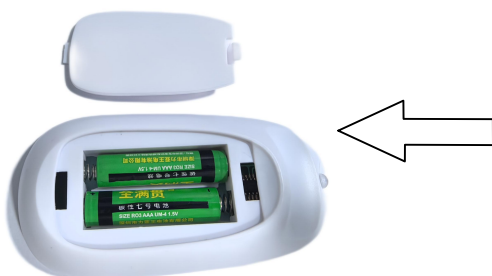

⑧



Certificate of Compliance

Certificate Number: DL-2022072129C

Applicant: Eyue Technology Co., Ltd
2F, XINWANGYUAN HIGH-TECH INDUSTRIAL PARK, ZHANGMUTOU TOWN, DONGGUAN, GUANGDONG, 523627 CHINA

Manufacturer: Eyue Technology Co., Ltd
2F, XINWANGYUAN HIGH-TECH INDUSTRIAL PARK, ZHANGMUTOU TOWN, DONGGUAN, GUANGDONG, 523627 CHINA

Product: USB Charger

M/N: EY-U222
EY-U112, EY-U212, EY-U312, EY-U412, EY-U612, EY-U122, EY-U322, EY-U422, EY-U132, EY-U232, EY-U332, EY-U432, EY-U142, EY-U242, EY-U342, EY-U442, EY-U152, EY-U252, EY-U352, EY-U452, EY-UXXX, EY-U512, EY-U712, EY-U812, EY-U522, EY-U622, EY-U722, EY-U822, EY-U532, EY-U632, EY-U732, EY-U832, EY-U542, EY-U642, EY-U742, EY-U842, EY-U552, EY-U652, EY-U752, EY-U852

Test Standard: EN 55015:2013+A1:2015
EN 61000-3-2:2014, EN 61000-3-3:2013
EN 61547:2009
EN 61000-4-2:2009, EN 61000-4-3: 2006+A1:2008+A2:2010
EN 61000-4-4:2012, EN 61000-4-5:2014, EN 61000-4-6:2014
EN 61000-4-8:2010, EN 61000-4-11:2004

The EUT described above has been tested by us with the listed standards and found in compliance with the council EMC directive 2014/30/EU. It is possible to use CE marking to demonstrate the compliance with this EMC Directive. It is only valid in connection with the test report number: DL-2022072129E.



CERTIFICATE



of Conformity
Low Voltage Directive 2014/35/EU

Registration No.: AN 50489215 0001

Report No.: 60387434 001

Holder: SHENZHEN BOYAXUAN TECHNOLOGY DEVELOPMENT CO., LTD.
3/F, 1st Building,
Xing Wei (Feng Huang)
Third Industrial Area, Fuyong Street,
Shenzhen
518100 Guangdong
P.R. China

Product: Power Supply
(AC/DC ADAPTER)

Identification: Type Designation: BYX2-XXXXYYF, BYX3-XXXXYYZ (BOYAXUAN)
For detail of the variables XXX, YYY and Z refer to
TUV Rheinland license S 50489196 pages 0001-0002.
Serial No.: N.A.
Remark: Issued in conjunction with above TÜV Rheinland
license.

This certificate of conformity is based on an evaluation of a sample of the above mentioned product. Technical Report and documentation are at the License Holder's disposal. This is to certify that the tested sample is in conformity with Annex I of Council Directive 2014/35/EU, referred to as the Low Voltage Directive. This certificate does not imply assessment of the series-production of the product and does not permit the use of a TÜV Rheinland mark of conformity. The holder of the certificate is authorized to use this certificate in connection with the EC declaration of conformity according to Annex IV of the Directive.



Certification Body

Date 25.01.2021

Dipl.-Ing. Univ. H. O. Steinko

TÜV Rheinland LGA Products GmbH - Tillystraße 2 - 90431 Nürnberg

CE The CE marking may be used if all relevant and effective EC Directives are complied with. CE

Certificate of Conformity

Certificate Number: DL-20230412023C

Applicant: Shenzhen Blue The Light Technology co., Ltd.
Floor 4, Building 2, Hongxing Industrial Park, Yuanling Village, Shiyan Town, Baoan District, Shenzhen, China

Manufacturer: Shenzhen Blue The Light Technology co., Ltd.
Floor 4, Building 2, Hongxing Industrial Park, Yuanling Village, Shiyan Town, Baoan District, Shenzhen, China

Product: LED Strip

Model No.: LG-5050-60L
LG-5050-30L, LG-5050-72L, LG-5050-84L, LG-5050-96L, LG-5050-120L,
LG-2835-60L, LG-2835-90L, LG-2835-96L, LG-2835-108L, LG-2835-120L,
LG-2835-140L, LG-2835-160L, LG-2835-240L

Test Standard: EN IEC 55015:2019+A11:2020
EN IEC 61000-3-2:2019+A1:2021, EN 61000-3-3:2013+A1:2019+A2:2021
EN 61547:2009
EN 61000-4-2:2009, EN IEC 61000-4-3:2020, EN 61000-4-4:2012,
EN 61000-4-5:2014+A1:2017, EN IEC 61000-4-6:2022,
EN 61000-4-8:2010, EN IEC 61000-4-11:2020

The EUT described above has been tested by us with the listed standards and found in compliance with the council EMC directive 2014/30/EU. It is possible to use CE marking to demonstrate the compliance with this EMC Directive. It is only valid in connection with the test report number: DL-20230412023E.



This certificate of conformity is based on a single evaluation of the submitted sample(s) of the above mentioned product. It does not imply an assessment of the whole product and relevant. Without the written approval, it is not permitted to use the test lab's logo.

Shenzhen DL Testing Technology Co., Ltd.
101-201, Building C, Shuangshan, No.8, Baoqing Road, Baulong Industrial Zone, Baulong Street,
Longgang District, Shenzhen, Guangdong, China

Web: www.dl-test.com E-mail: Service@dl-test.com Tel: 400-688-5532

