

MONTAGEINSTRUKTIONEN

Tagesbett

SKU : N636P171588
N636P171593
N636P171594

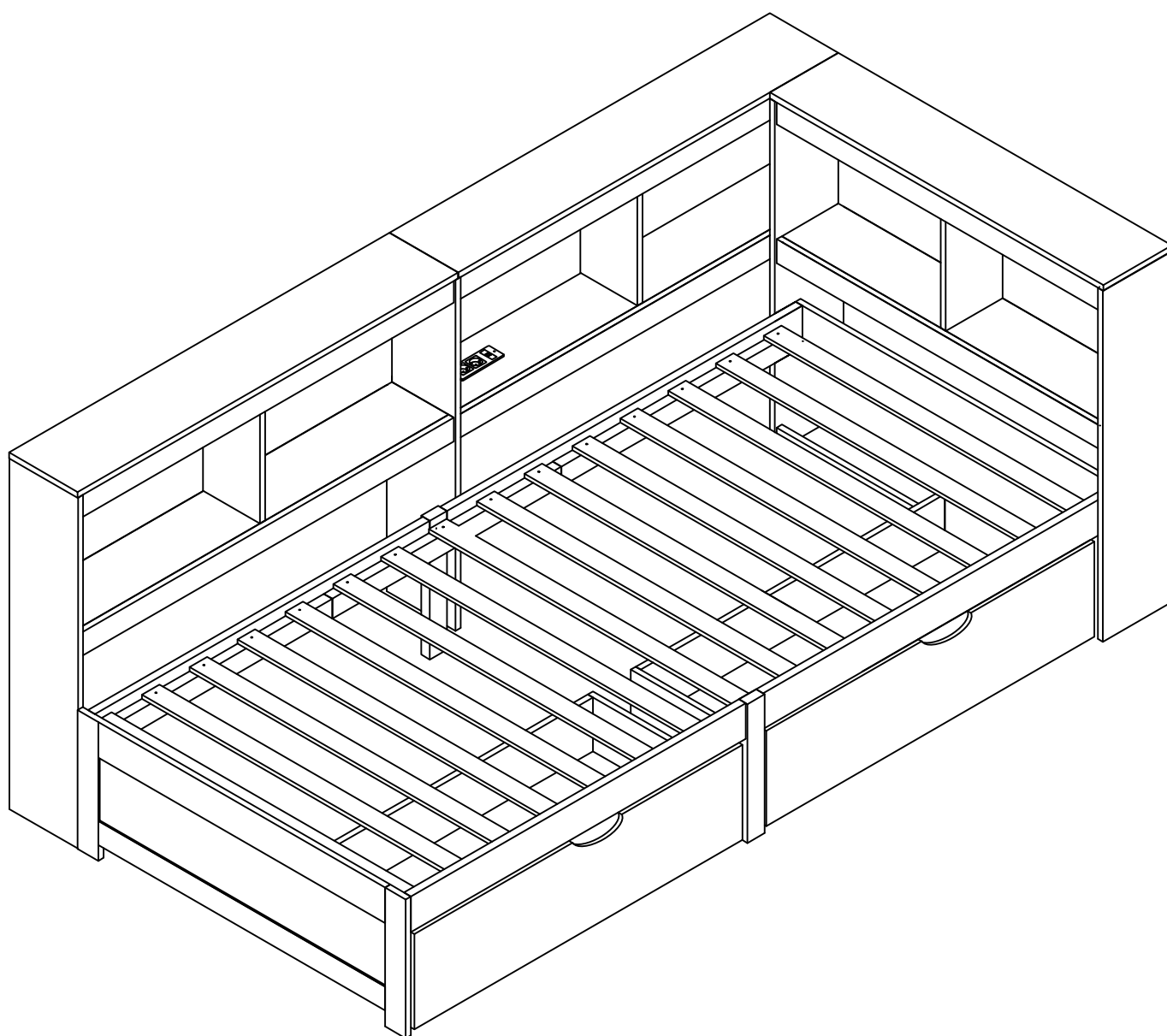

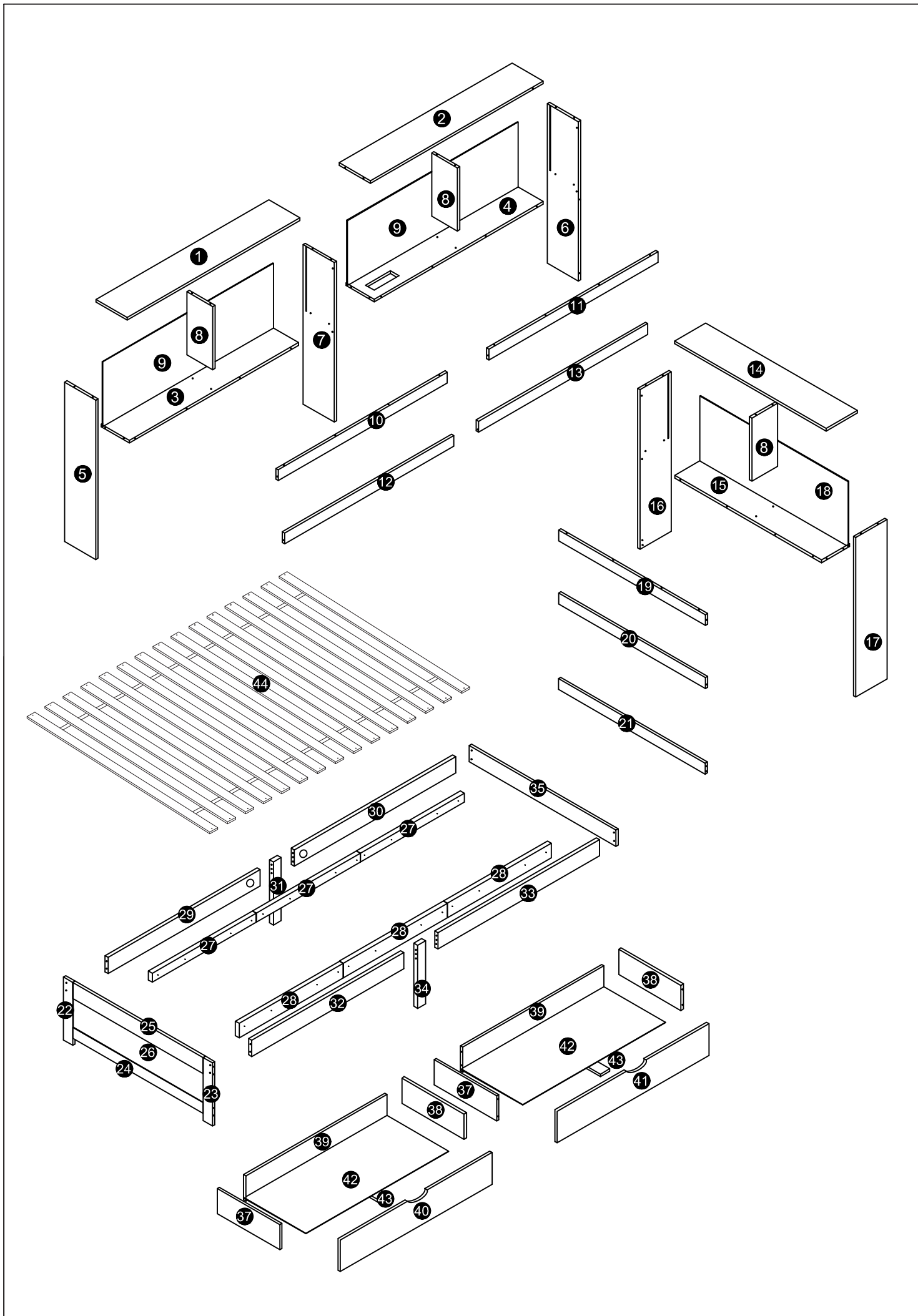

N636P171588

3 x1

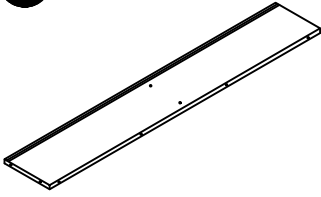

4 x1

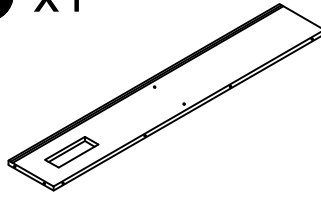

10 x1

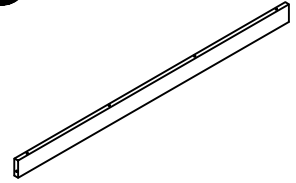

14 x1

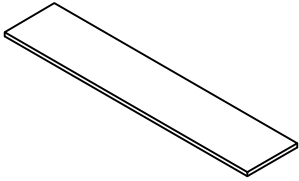

15 x1

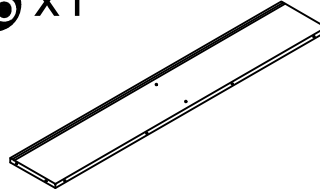

19 x1

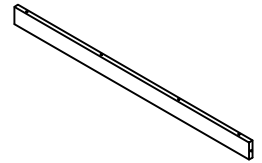

21 x1

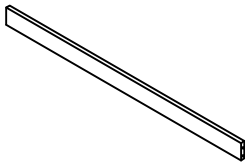

26 x1

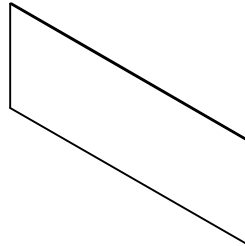

29 x1

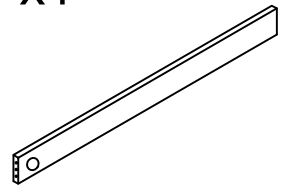

30 x1

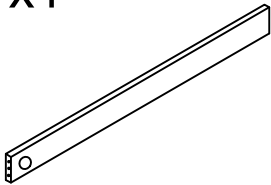

32 x1

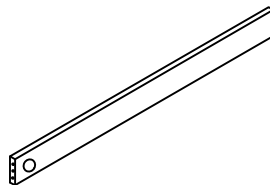

33 x1

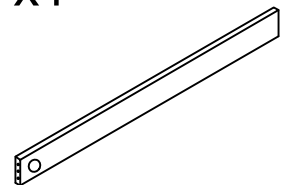

39 x1

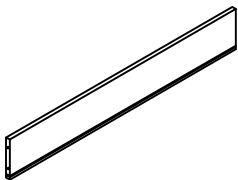

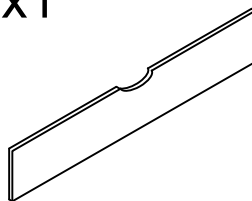

40 x1

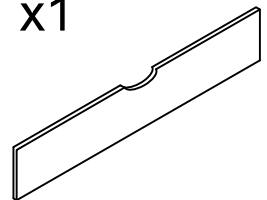

41 x1

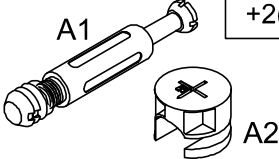
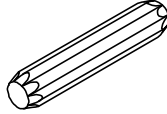
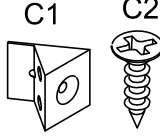
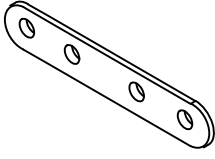
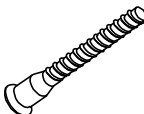
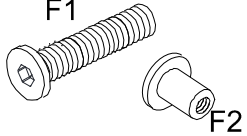

N636P171588

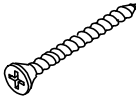
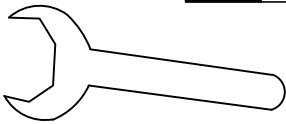
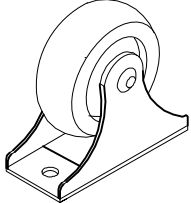
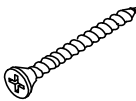
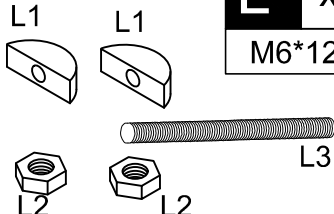
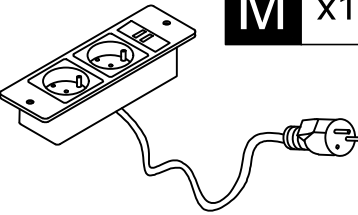
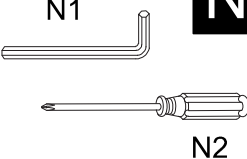
 <p>A x87 +2(spare)</p>	 <p>B x14 M8*40 +1(spare)</p>	 <p>C x12 M3*14 +2(spare)</p>
 <p>D x2</p>	 <p>E x4 M7*50</p>	 <p>F x4</p>
 <p>G x26 M3.5*14 +2(spare)</p>	 <p>H x72 M3.5*35 +2(spare)</p>	 <p>I x1</p>
 <p>J x8</p>	 <p>K x8 M4*100</p>	 <p>L x2 M6*120</p>
 <p>M x1</p>	 <p>N x1</p>	

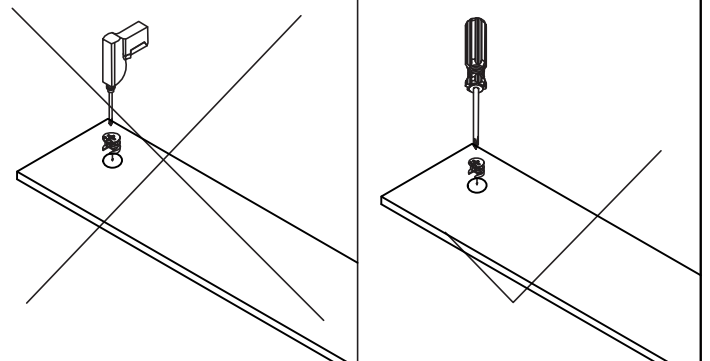
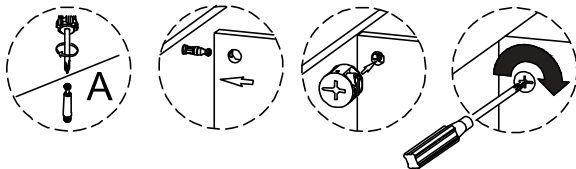

N636P171593

1 x1

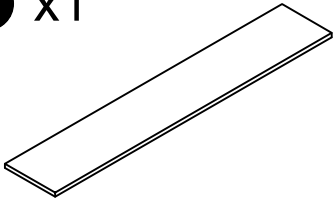

2 x1

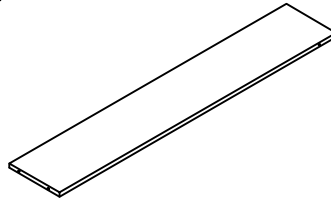

8 x3



9 x2

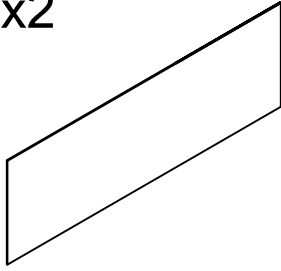

11 x1

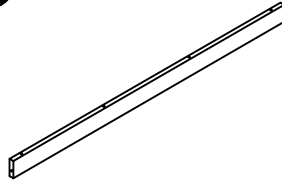

12 x1

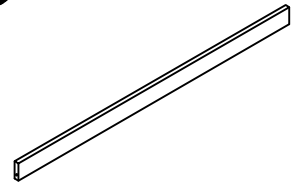

13 x1

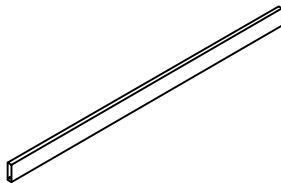

18 x1

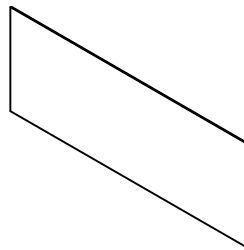

37 x2

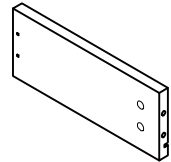

38 x2

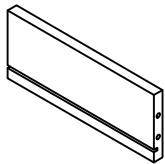

42 x2

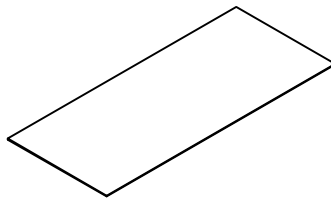

44 x1

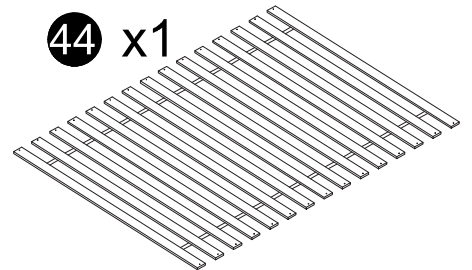

N636P171594

5 x1

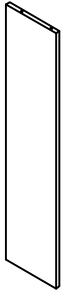

6 x1



7 x1



16 x1

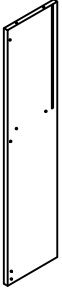

17 x1



20 x1

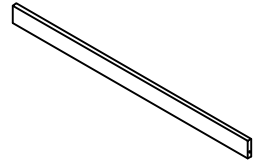

22 x1



23 x1



24 x1

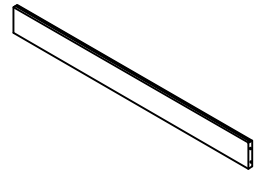

25 x1

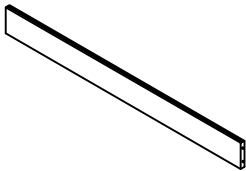

27 x3

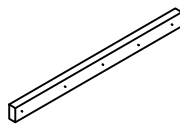

28 x3

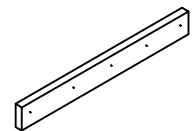

31 x1



34 x1



35 x1

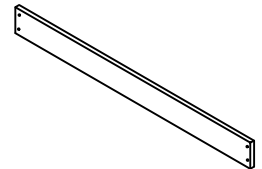

39 x1

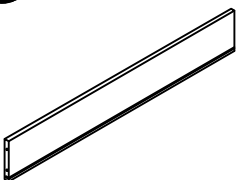

43 x2

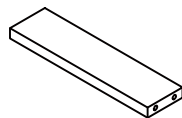

SCHRITT 1:

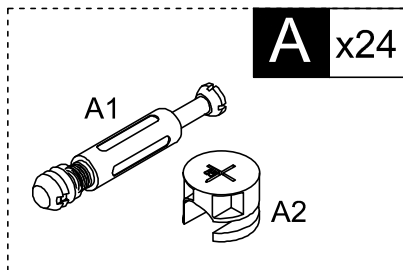
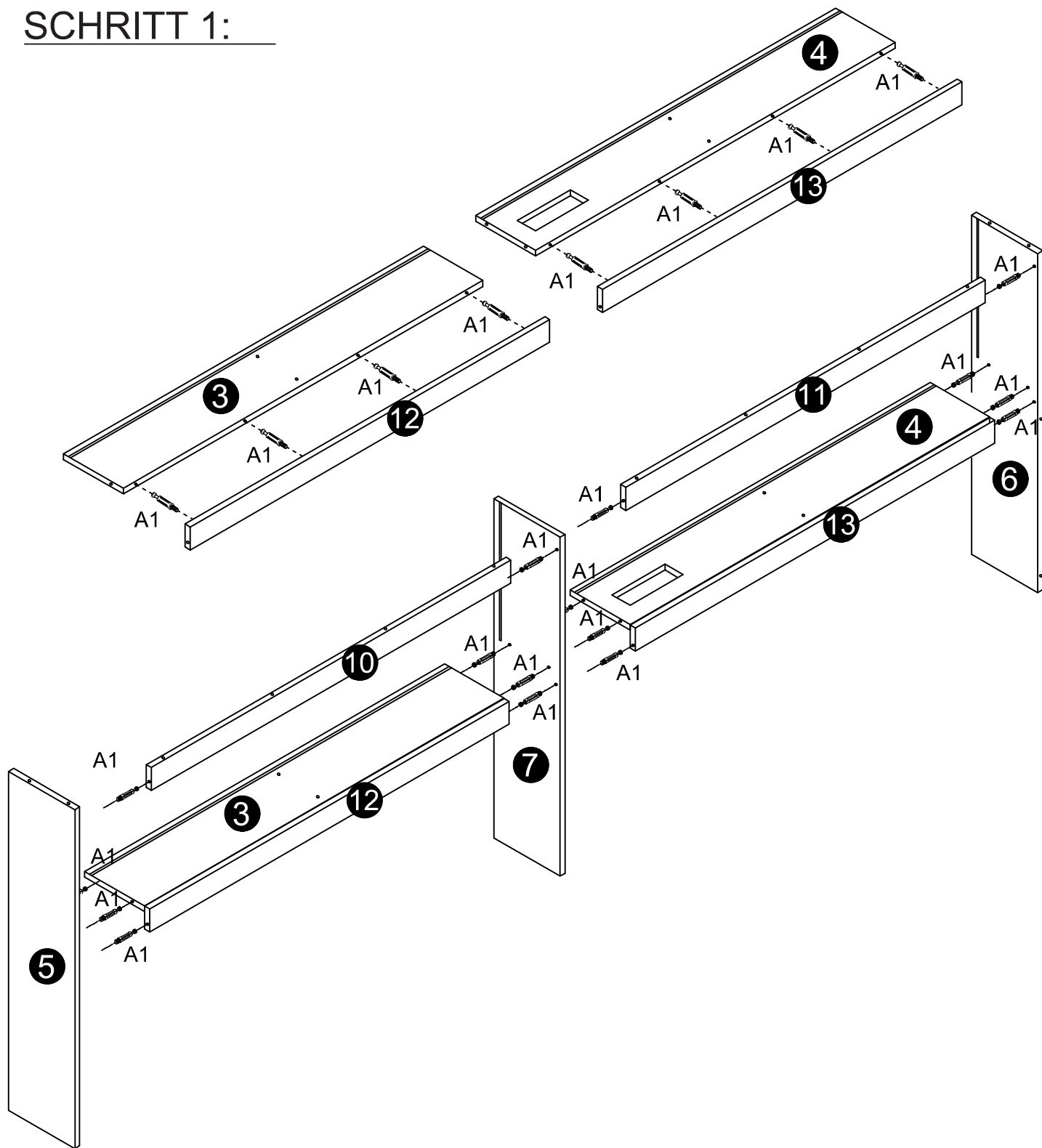

SCHRITT 2:

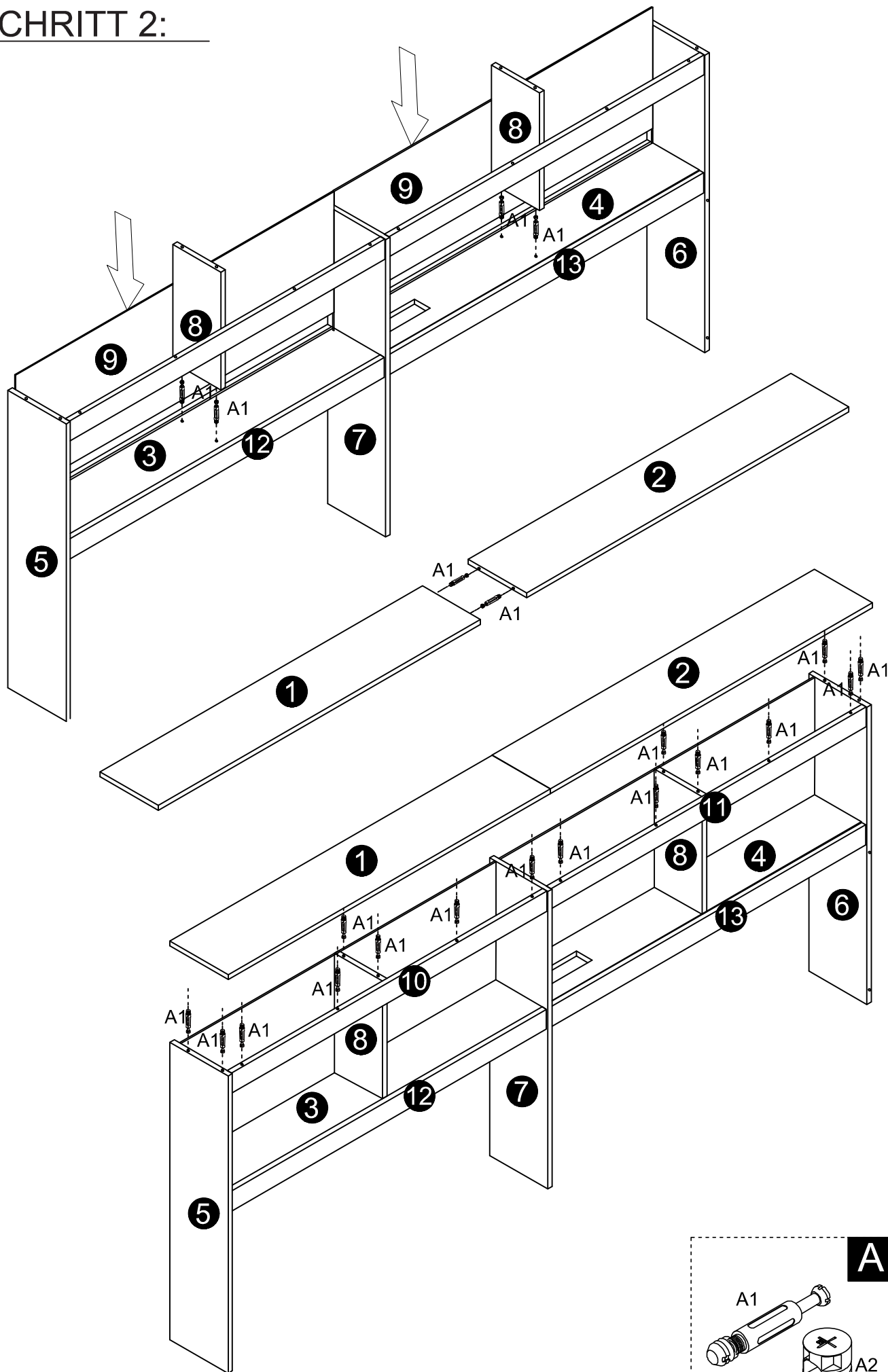

SCHRITT 3:

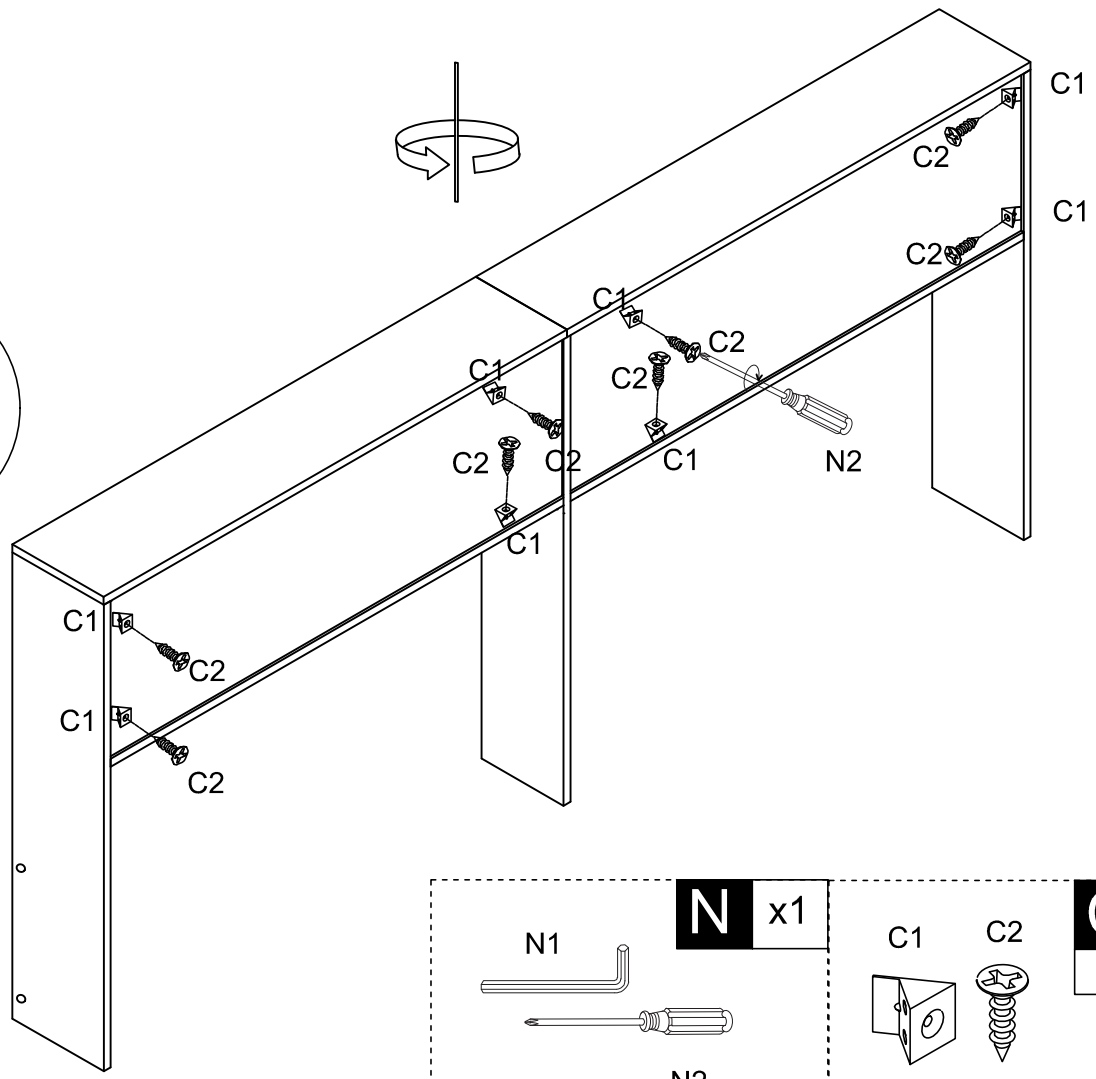
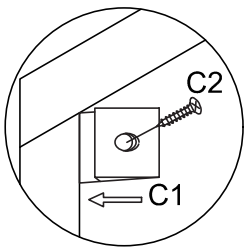
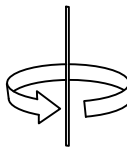
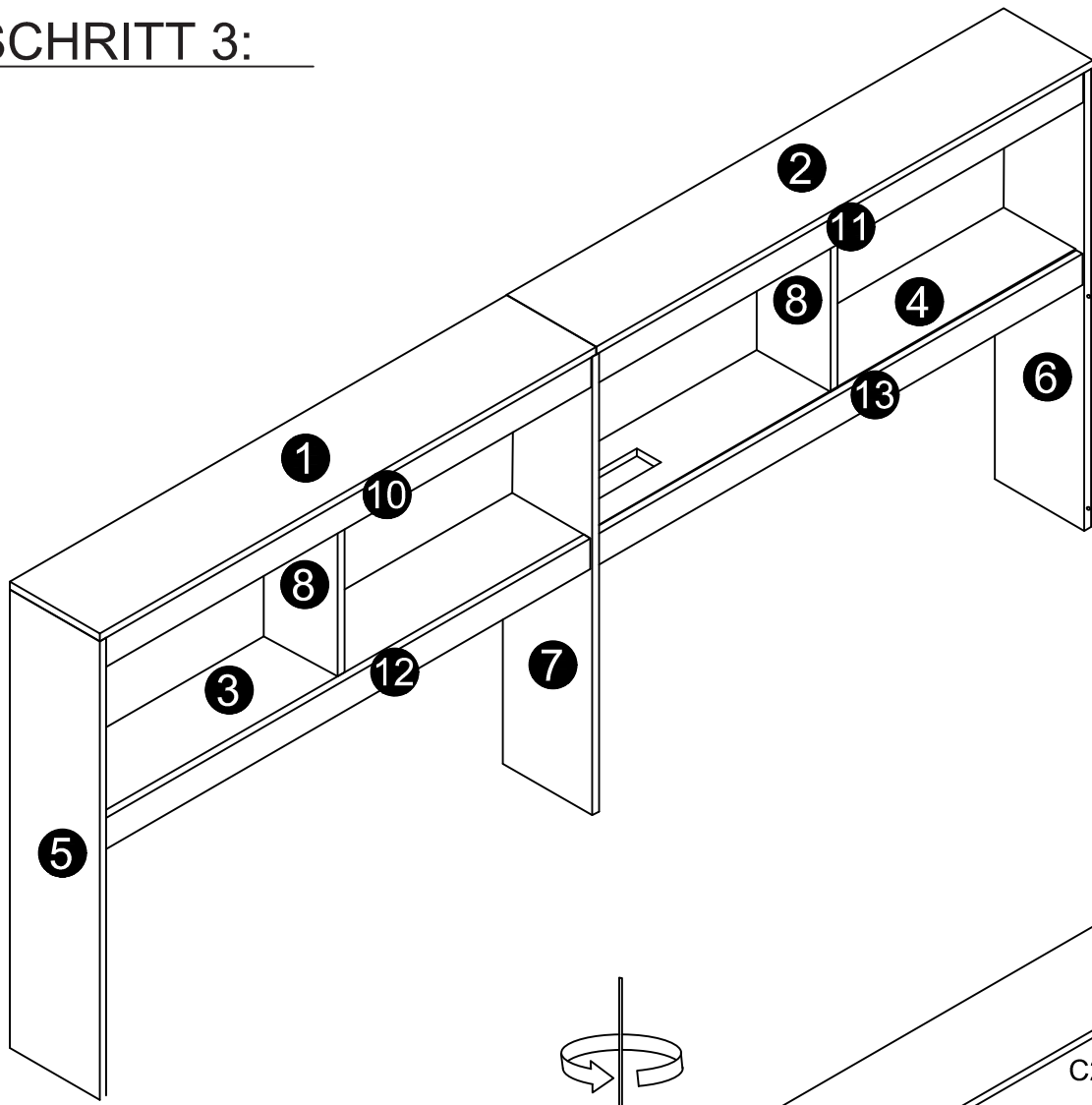

		N x1
		C x8 M3*14
		C 2
		C 2

SCHRITT 4:

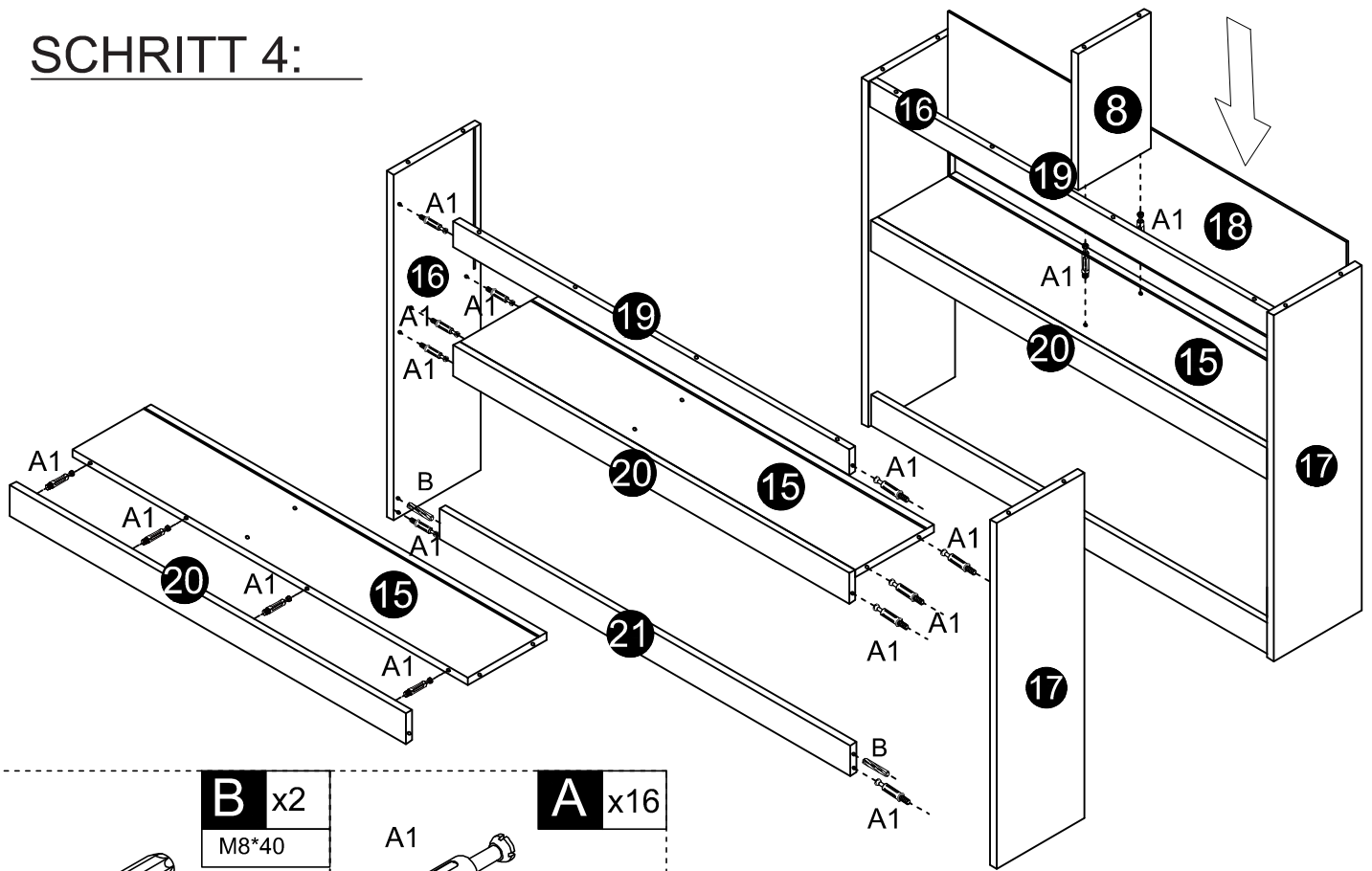

B x2
M8*40

A x16

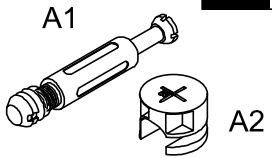
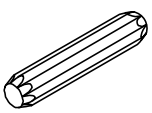

SCHRITT 5:

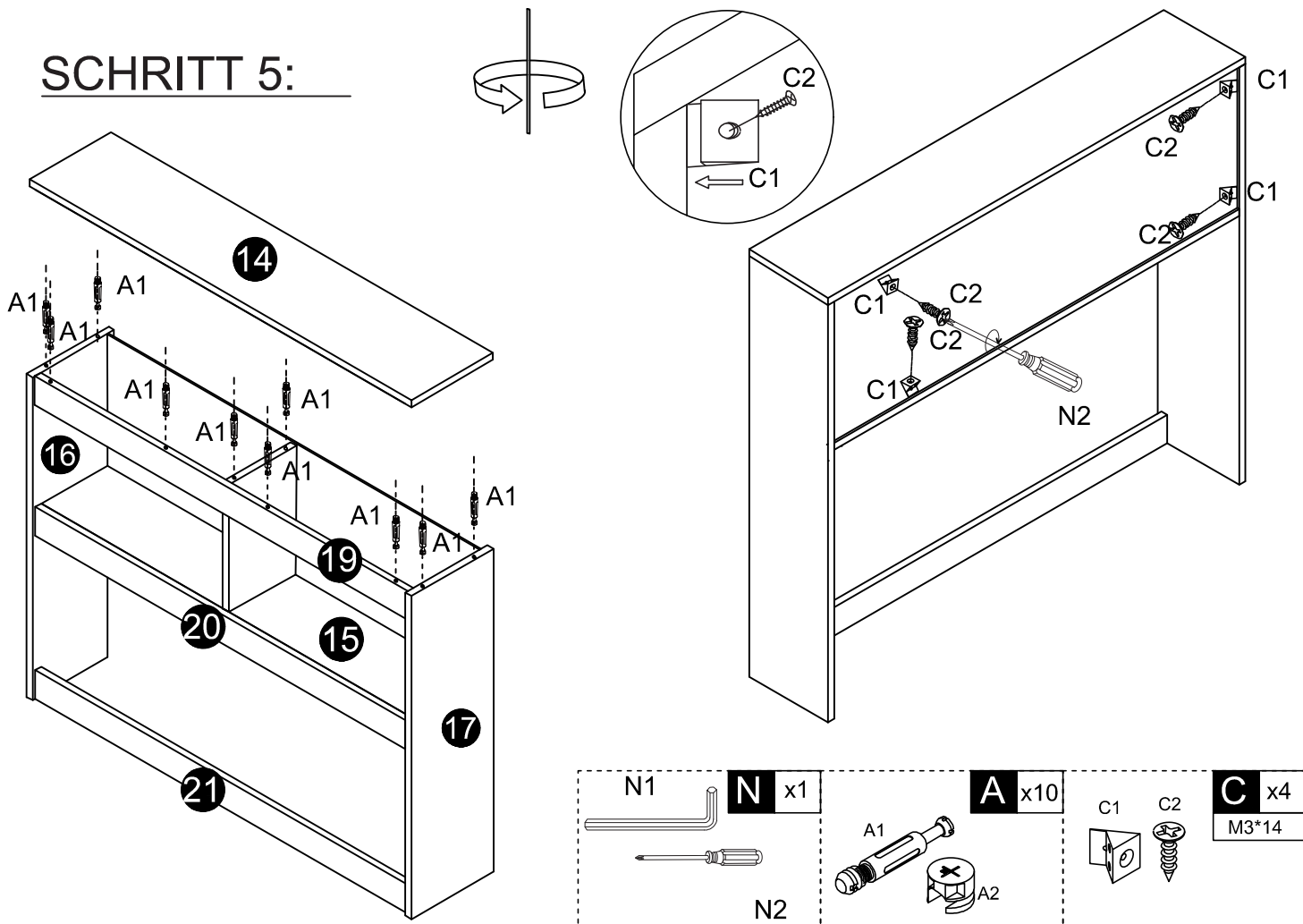

N x1

A x10

C x4
M3*14

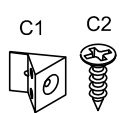
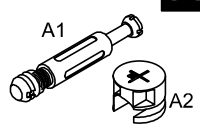
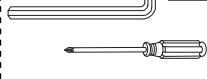

SCHRITT 6:

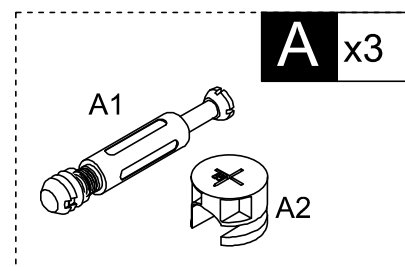
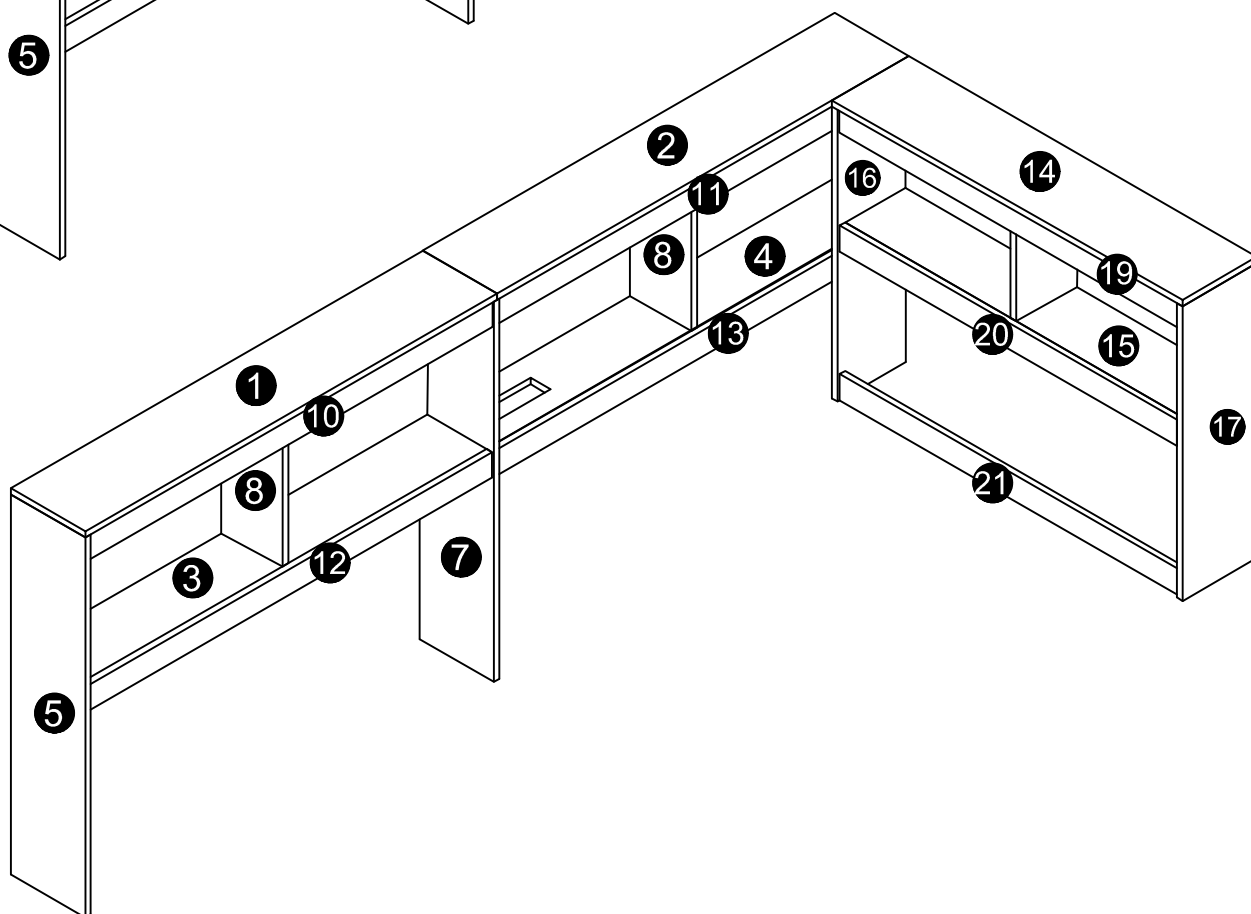
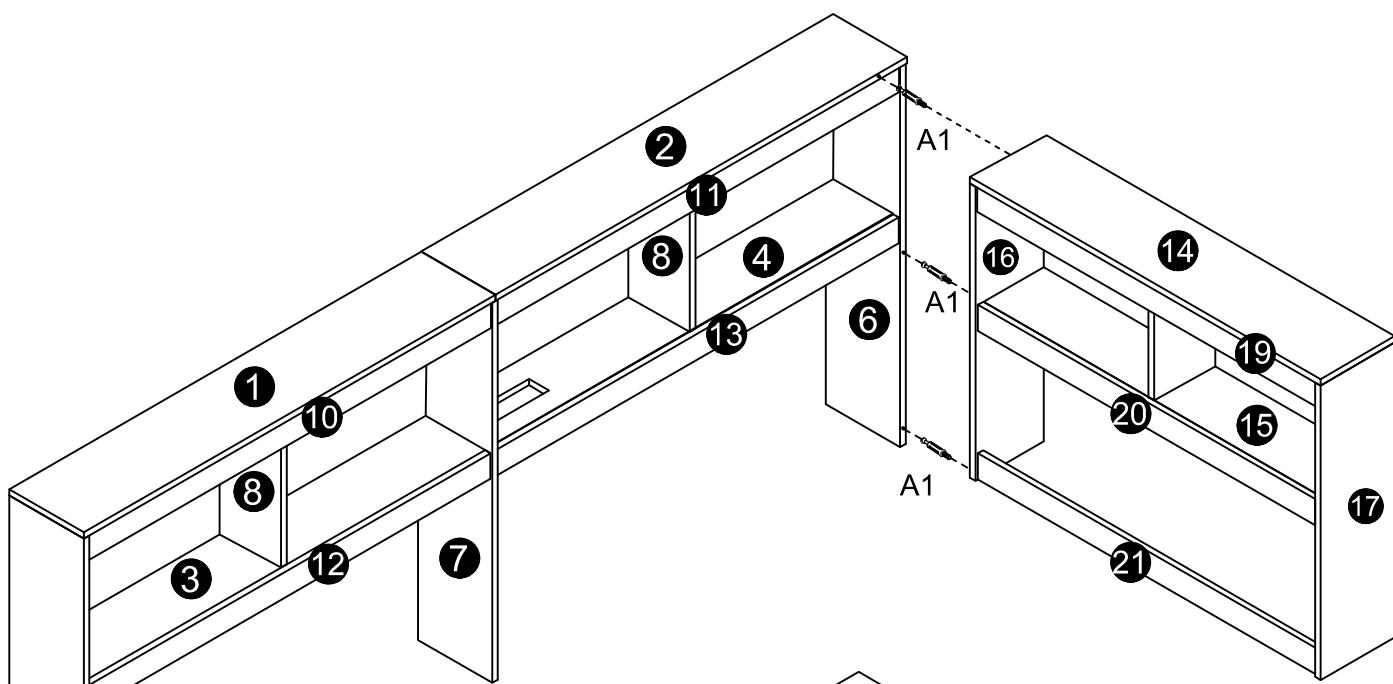

SCHRITT 7:

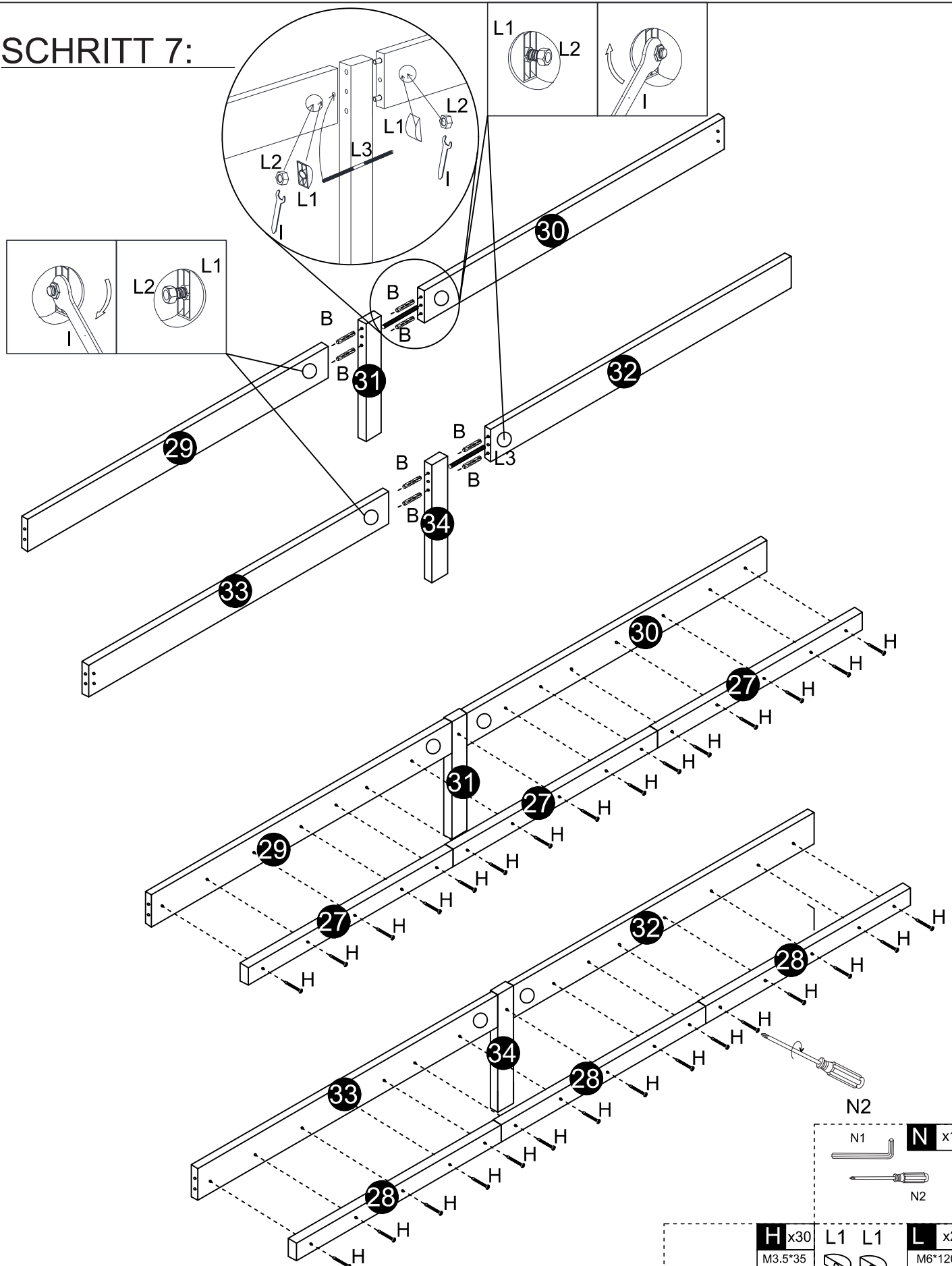

Man beachte die unterschiede zwischen den zähnen der nr. 31 und der nr. 34 innen und außen. Als die montage fertig war, wurden die teller 31 mit den platten 29 und 30 ebenerdig und die teller 34 mit den platten 32 und 33.

- | | | | | | |
|---------|--|-------|--|------|--|
| N2 | | N1 | | N x1 | |
| | | | | | |
| N2 | | | | | |
| H x30 | | L1 L1 | | L x2 | |
| M3.5*35 | | | | | |
| | | L2 L2 | | L3 | |
| | | | | | |
| | | | | | |
| B x8 | | | | I x1 | |
| M8*40 | | | | | |
| | | | | | |
| | | | | | |

SCHRITT 8:

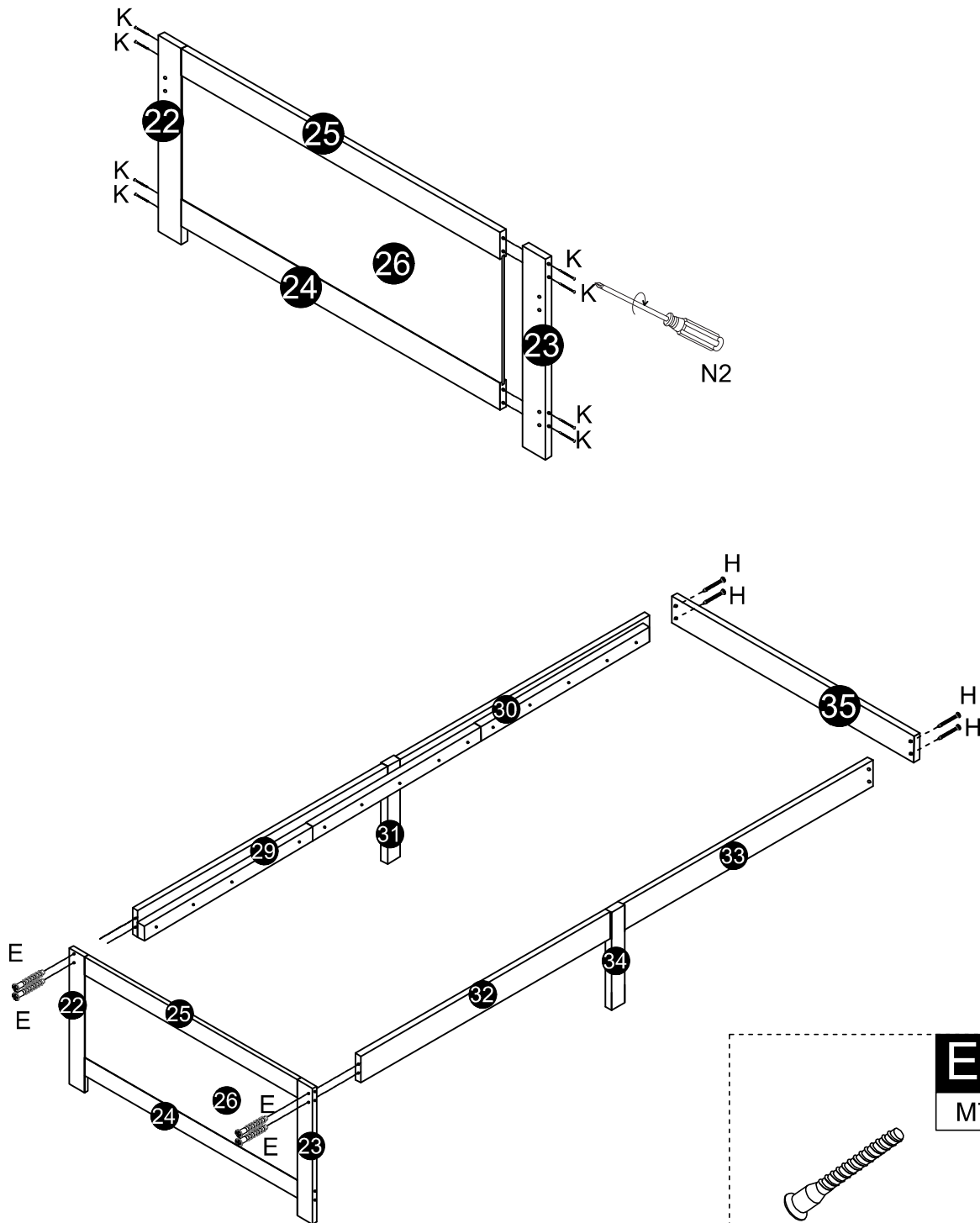

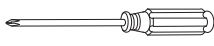
N1	N x1
	
N2	

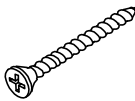
K x8	
M4*100	
	

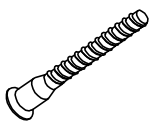
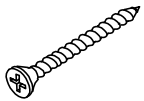
E x4	
M7*50	
	
H x4	
M3.5*35	
	

SCHRITT 9:

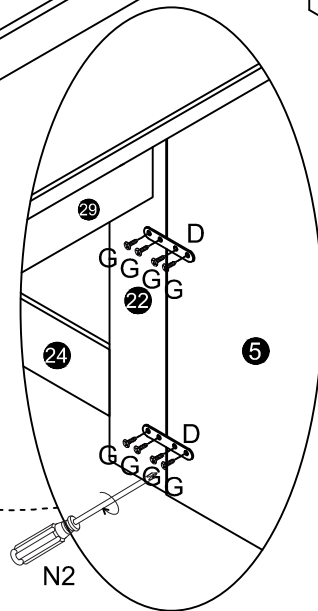
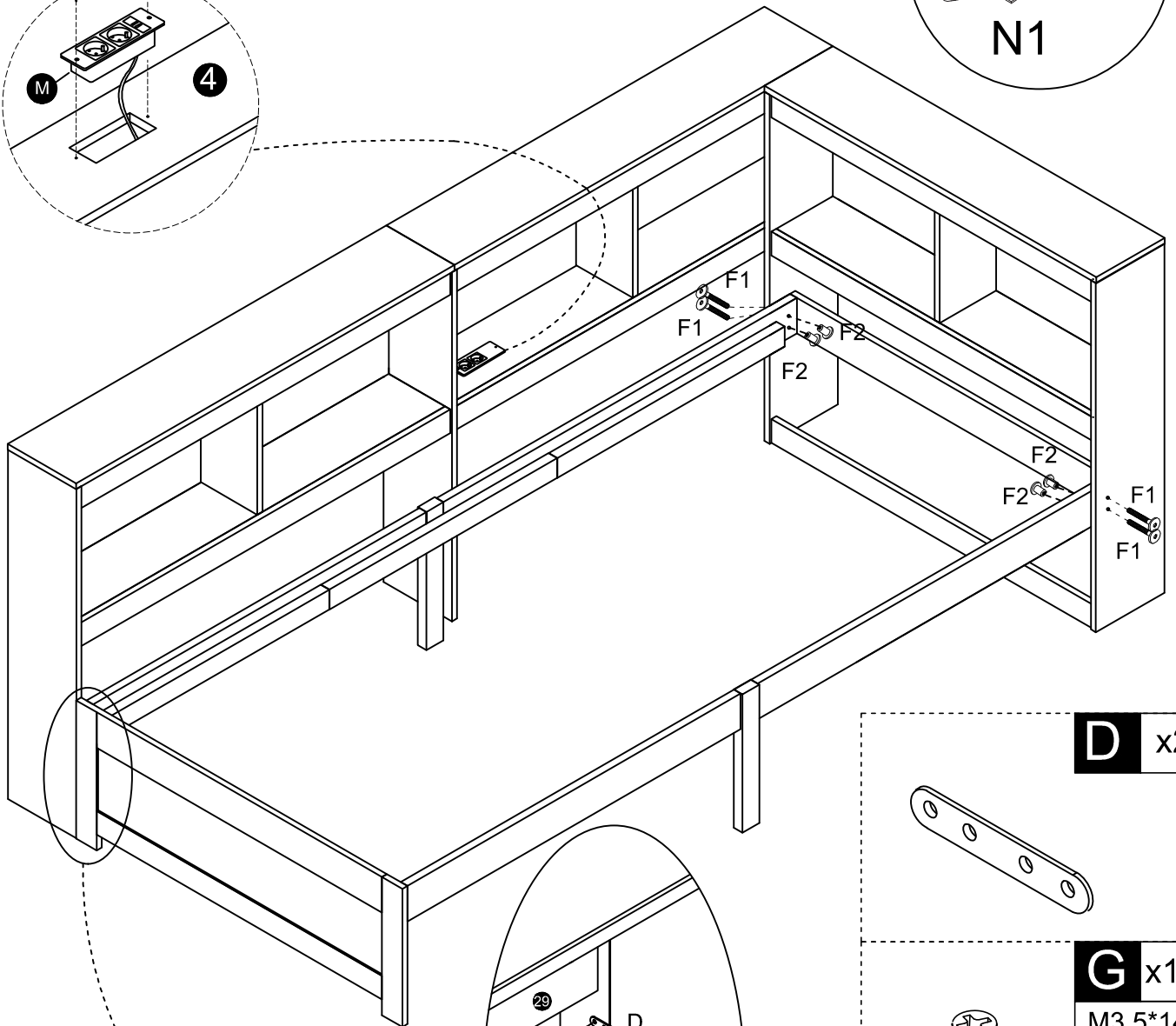
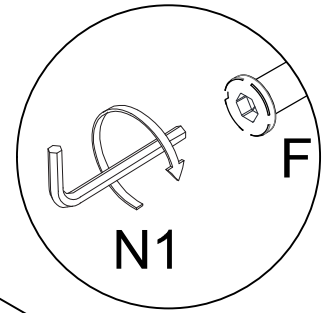
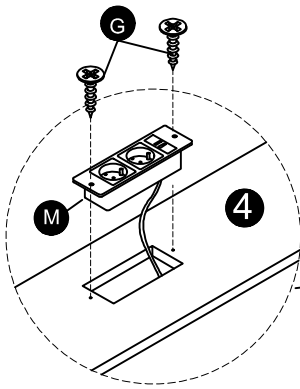

D x2

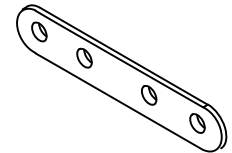

G x10
M3.5*14



F x4

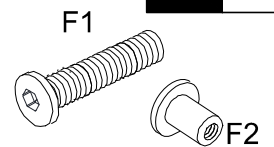

N x1

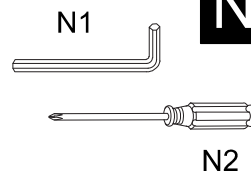



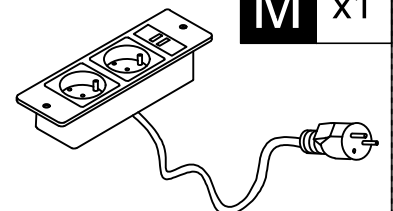

M x1

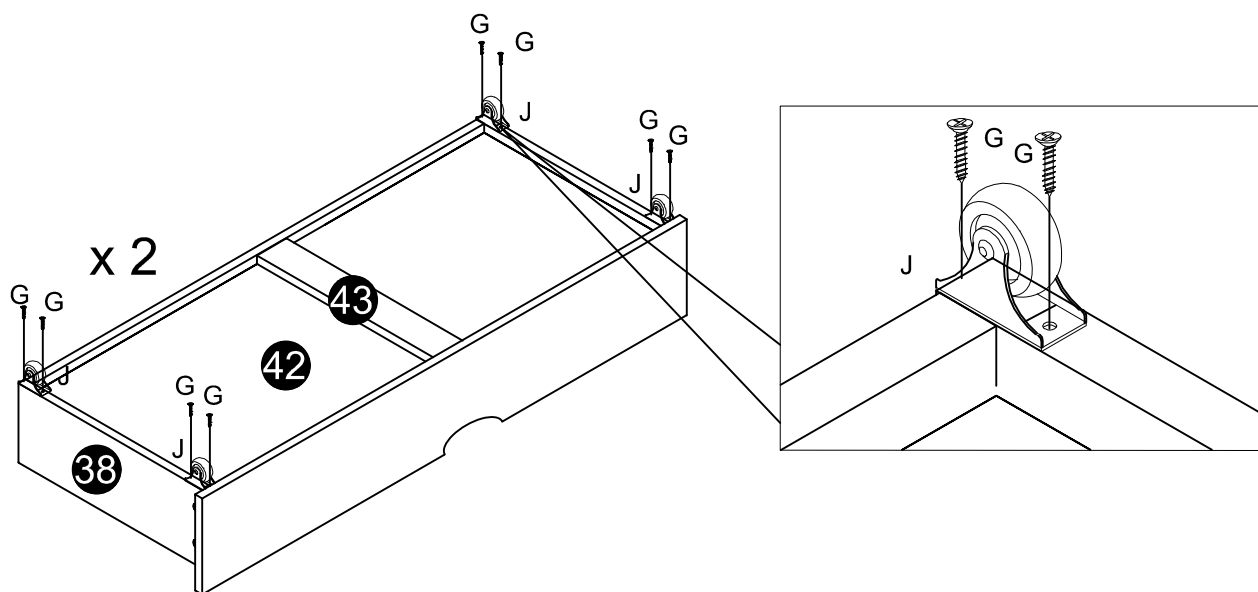
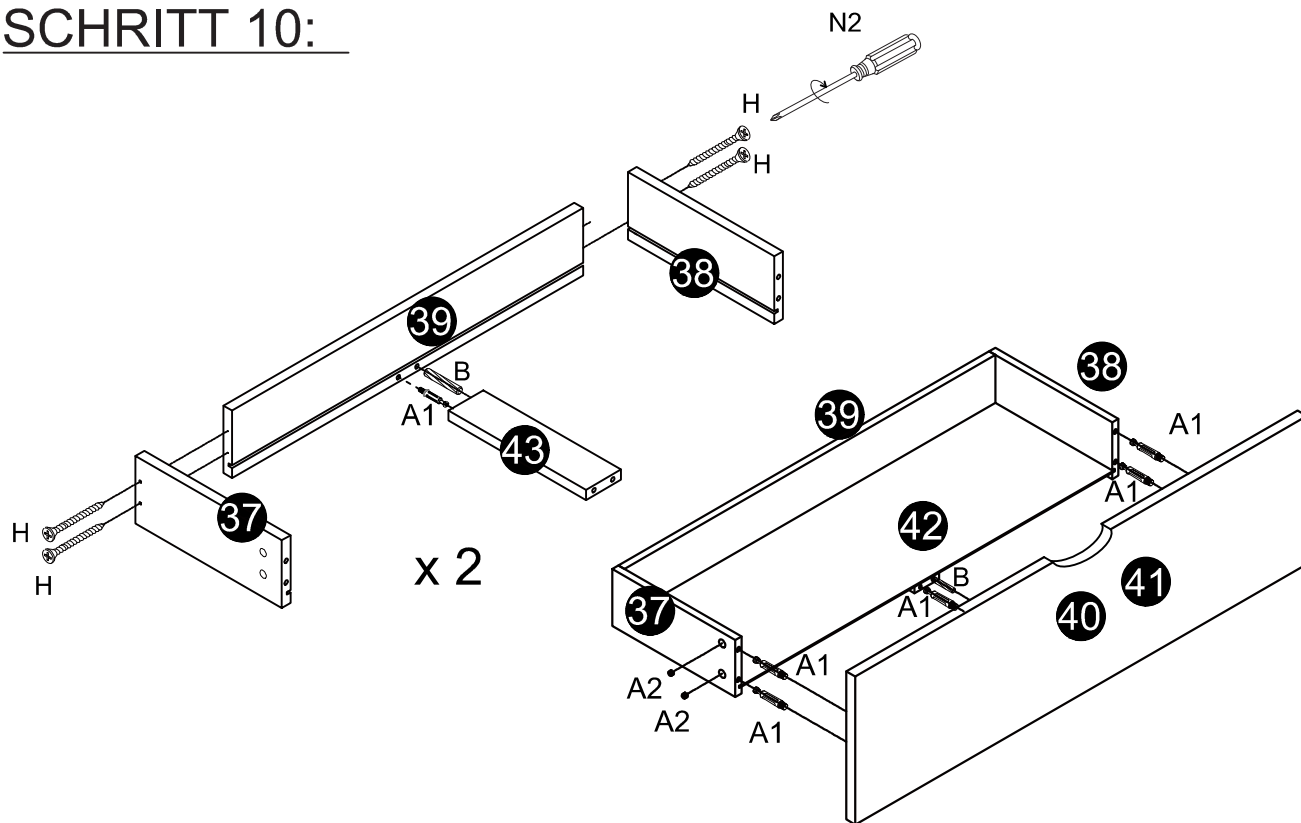

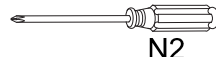
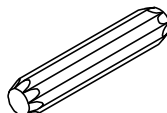
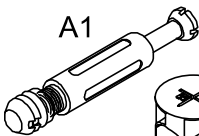
SCHRITT 10:

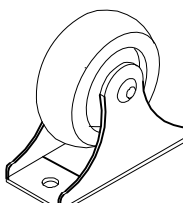

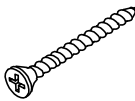
 <p>N x1</p>  <p>N2</p>	 <p>B x4 M8*40</p>	 <p>A x12</p>  <p>A2</p>
 <p>J x8</p>	 <p>G x16 M3.5*14</p>	 <p>H x8 M3.5*35</p>

SCHRITT 11:

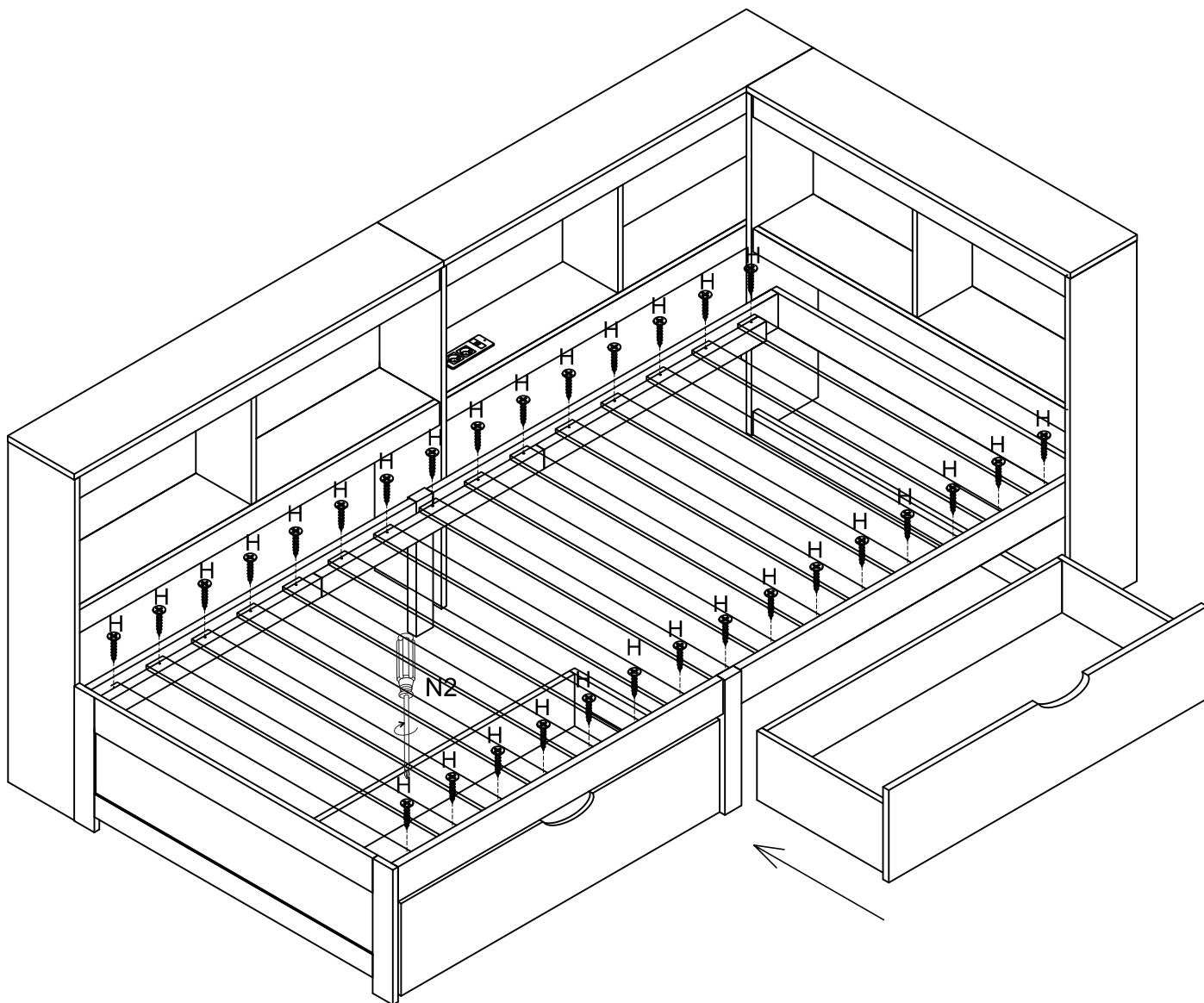

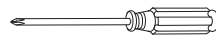
N1	N x1	H x30
	N2	M3.5*35 +2(spare)
		