

MONTAGEANLEITUNG/ASSEMBLY INSTRUCTIONS

Artikelnummer/Item Number: WF314085
WF314086

Dieses Set ist in 2 Boxen enthalten. Wenn Sie keine vollen 2 Boxen erhalten, wenden Sie sich bitte an unseren Kundenservice.

This set comes in 2-boxes, If you do not receive a full 2-boxes, please contact our customer service.

Hausbett mit Fenster Natur 200x90cm

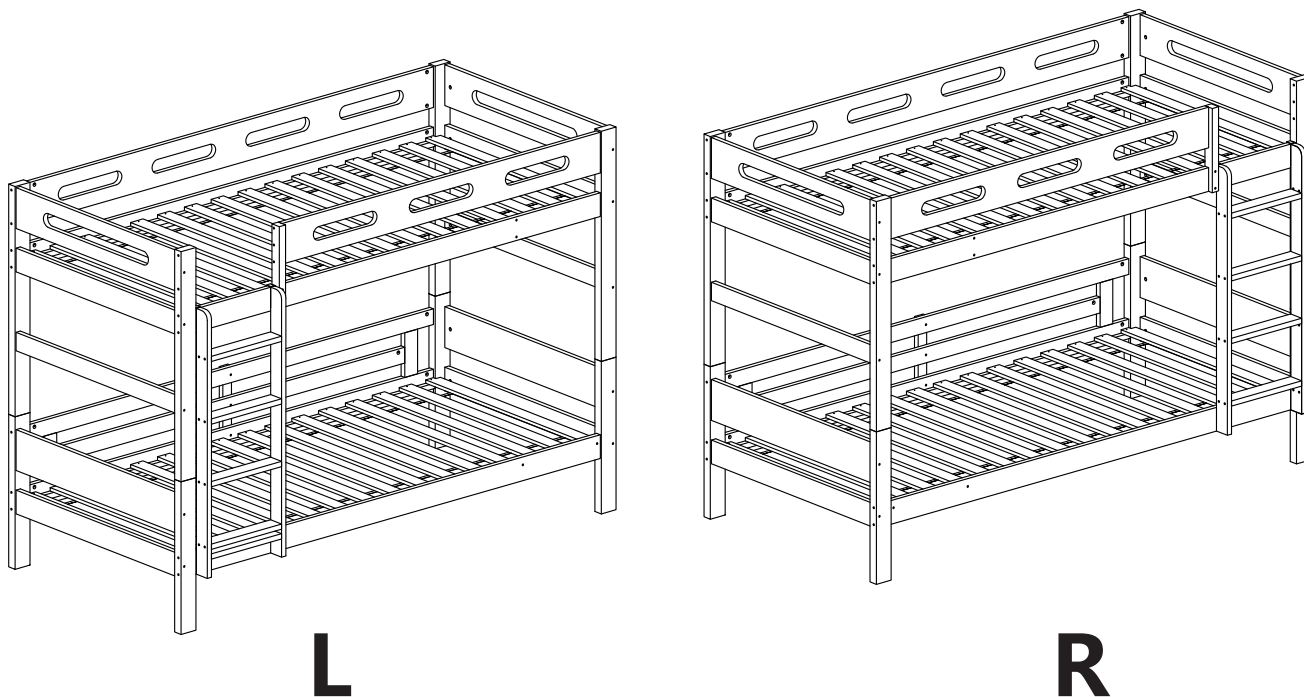

English

IMPORTANT ! KEEP FOR FUTURE REFERENCE : READ CAREFULLY

- To be assembled by an adult. Assembly must be checked by an adult before use
- WARNING ! Keep all screws, small parts and plastic bags out of the reach of children
- Properly identify all parts before assembling
- Never use your item if any of its parts are broken or missing
- Should any problems arise, please contact our After Sales Service
- Manufacturer's instructions shall be followed at all times
- Care: Clean with a soft, dry cloth. In case of larger stains, carefully rub with a slightly damp, non-abrasive sponge
- Avoid the risk of fire by not placing furniture near sources of ignition or hot items
- Do not jump on the bed

Deutsch

WICHTIG ! ZUM SPÄTEREN NACHSCHLAGEN AUFBEWAHREN: SORGFÄLTIG LESEN

- Muss von einem Erwachsenen zusammengebaut werden. Der Zusammenbau muss vor dem Gebrauch von einem Erwachsenen überprüft werden
- WARNUNG! Bewahren Sie alle Schrauben, Kleinteile und Plastikbeutel außerhalb der Reichweite von Kindern auf
- Kennzeichnen Sie vor dem Zusammenbau alle Teile richtig
- Benutzen Sie Ihren Artikel niemals, wenn Teile gebrochen sind oder fehlen
- Sollten Probleme auftreten, wenden Sie sich bitte an unseren Kundendienst
- Die Anweisungen des Herstellers sind stets zu befolgen
- Pflege: Mit einem weichen, trockenen Tuch reinigen. Bei größeren Flecken vorsichtig mit einem leicht feuchten, nicht scheuernden Schwamm abreiben. nicht scheuernden Schwamm
- Vermeiden Sie die Gefahr eines Brandes, indem Sie die Möbel nicht in der Nähe von Zündquellen oder heißen Gegenständen aufstellen
- Nicht auf das Bett springen

Français

IMPORTANT ! CONSERVER POUR RÉFÉRENCE ULTÉRIEURE : LIRE ATTENTIVEMENT

- Le montage doit être effectué par un adulte. Le montage doit être vérifié par un adulte avant Utilisation
- ATTENTION ! Tenir les vis, les petites pièces et les sachets en plastique hors de portée des enfants
- Identifiez correctement toutes les pièces avant de les assembler
- N'utilisez jamais votre article si l'une de ses pièces est cassée ou manquante
- En cas de problème, veuillez contacter notre service après-vente
- Les instructions du fabricant doivent être respectées à tout moment
- Entretien : nettoyer avec un chiffon doux et sec. En cas de taches plus importantes, frotter soigneusement avec une éponge non abrasive légèrement humide. légèrement humide et non Abrasive
- Évitez les risques d'incendie en ne plaçant pas les meubles à proximité de sources d'inflammation ou d'objets chauds
- Ne pas sauter sur le lit

Italiano

IMPORTANTE! CONSERVARE PER RIFERIMENTO FUTURO: LEGGERE ATTENTAMENTE

- Deve essere assemblato da un adulto. L'assemblaggio deve essere controllato da un adulto prima dell'uso
- **ATTENZIONE!** Tenere tutte le viti, le piccole parti e i sacchetti di plastica fuori dalla portata dei bambini
- Identificare correttamente tutte le parti prima dell'assemblaggio
- Non utilizzare mai l'articolo se alcune parti sono rotte o mancanti
- In caso di problemi, si prega di contattare il nostro Servizio Post Vendita
- Le istruzioni del produttore devono essere sempre seguite
- Cura: Pulire con un panno morbido e asciutto. In caso di macchie più estese, strofinare accuratamente con una spugna leggermente umida e nonspugna leggermente umida e non abrasiva
- Evitare il rischio di incendio, non collocando i mobili vicino a fonti di accensione o a oggetti caldi
- Non saltare sul letto

Español

¡ IMPORTANTE ! CONSERVELO PARA FUTURAS CONSULTAS: LEA ATENTAMENTE

- Debe ser montado por un adulto. El montaje debe ser comprobado por un adulto antes del uso
- ADVERTENCIA Mantenga todos los tornillos, piezas pequeñas y bolsas de plástico fuera del alcance de los niños.
- Identifique correctamente todas las piezas antes de montarlas
 - Nunca utilice su artículo si alguna de sus piezas está rota o falta
 - Si surge algún problema, póngase en contacto con nuestro Servicio Postventa
 - Las instrucciones del fabricante deben seguirse en todo momento
 - Cuidado: Limpiar con un paño suave y seco. En caso de manchas más grandes, frote cuidadosamente con una esponja no abrasiva ligeramente humedecida.
 - Evite el riesgo de incendio no colocando los muebles cerca de fuentes de ignición u objetos calientes.
 - No saltar sobre la cama.

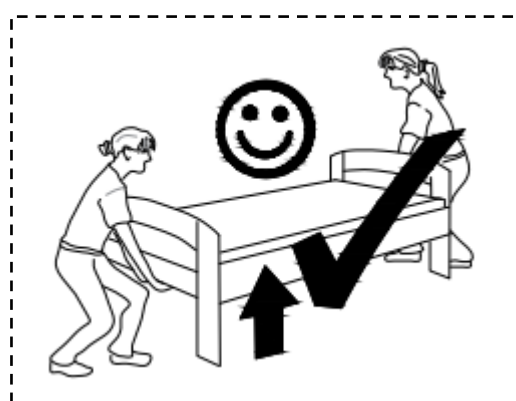
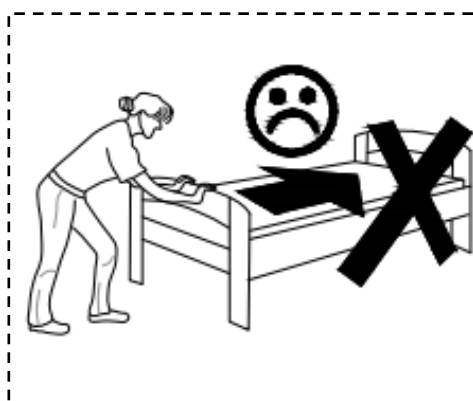

INSTRUCTIONS

IMPORTANT-READ CAREFULLY-RETAIN FOR FUTURE REFERENCE

- a) **WARNING**-High beds and the upper bed of bunk beds are not suitable for children under six years due to the risk of injury from falls;
- b) **WARNING**-Bunk beds and high beds can present a serious risk of injury from strangulation if not used correctly. Never attach or hang items to any part of the bunk bed that are not designed to be used with the bed, for example, but not limited to ropes, strings, cords, hooks, belts and bags.
- c) **WARNING**-Children can become trapped between the bed and the wall, a roof pitch, the ceiling adjoining pieces of furniture (e.g. cupboards) and the like. To avoid risk of serious injury the distance between the top safety barrier and the adjoining structure shall not exceed 75 mm or shall be more than 230 mm.
- d) **WARNING**-Do not use the bunk bed/high bed if any structural part is broken or missing; Replacement parts are between requested from the manufacturer or the store.
- e) it is imperative to always follow the installation instructions and manufacturer's use.
- f) The recommended size of the mattress to be used with the bed is **90x200cm**, maximum thickness mattress: **10cm**.
- g) It is necessary to ventilate the room in order to maintain a low level moisture and prevent mold growth in the bed and its periphery.
- h) Joining devices should always be tightened properly and regularly verified. Tighten if necessary.
- i) Meets European standard requirements NC safety EN 747-2024

ANLEITUNG

WICHTIG-SORGFÄLTIG DURCHLESEN-FÜR ZUKÜNFTIGE REFERENZ BEWAHREN

- a) **WARNUNG**-Das Oberbett von Etagenbett ist wegen der Verletzungsgefahr durch Stürze nicht für Kinder unter sechs Jahren geeignet.
- b) **WARNUNG**-Etagenbetten und Hochbetten können ein ernstes Verletzungsrisiko darstellen, wenn sie nicht ordnungsgemäß verwendet werden. Befestigen oder hängen Sie niemals etwas an einem Teil des Etagenbettes, das nicht für das Bett bestimmt ist, wie z. B. Seile, Haken, Gurte und Taschen.
- c) **WARNUNG**-Kinder können zwischen Bett und Wand eingeklemmt werden. Um die Gefahr schwerer Verletzungen zu vermeiden, darf der Abstand zwischen der oberen Sicherheitsbarriere und der angrenzenden Konstruktion 75 mm nicht überschreiten oder mehr als 230 mm betragen.
- d) **WARNUNG**-Verwenden Sie das Etagenbett nicht, wenn ein Bauteil beschädigt ist oder fehlt. Ersatzteile werden zwischendurch beim Hersteller oder beim Händler angefordert.
- e) Befolgen Sie unbedingt die Anweisung des Herstellers.
- f) Die empfohlene Größe der Matratze für das Bett beträgt **90x200cm**, maximale Dicke der Matratze: **10 cm**.
- g) Es ist notwendig, den Raum zu lüften, um ein niedriges Feuchtigkeitsniveau aufrechtzuerhalten und das Wachstum von Schimmel im Bett und an dessen Peripherie zu verhindern.
- h) Verbindungselemente sollten immer richtig angezogen und regelmäßig überprüft werden. Bei Bedarf festziehen.
- i) Erfüllt die Anforderungen der europäischen Norm NC-Sicherheit EN 747-2024



DE: Vor dem Einbau die Schrauben in die Löcher stecken und festziehen, aber nicht bis 100%, 70% bis 80% anziehen reicht aus. Schließlich, nachdem alle Schrauben installiert sind, ziehen Sie alle Schrauben auf 100%.

Wenn Sie auf diese Probleme stoßen, wie z. B. Fehlausrichtung der Löcher oder Unfähigkeit, bestimmte Teile zu installieren, überprüfen Sie bitte, ob die Schrauben korrekt verwendet werden und passen Sie die Dichtigkeit der Schrauben an.

UK: Before installation, insert the screws into the holes and tighten them, but do not tighten them to 100%, 70% to 80% is sufficient. Finally, after all screws are installed, tighten all screws to 100%.





If you encounter these issues, such as if the holes cannot be aligned or some parts cannot be installed, please check if the screws are used correctly and adjust the tightness of the screws.

FR: Insérer la vis dans le trou avant la fin de l'assemblage, serrer la vis, mais ne pas serrer à 100%, 70% ~ 80% est correct. Enfin, une fois que toutes les vis sont bien serrées, toutes les vis sont serrées à 100%.

Si vous rencontrez ces problèmes, par exemple si les trous ne sont pas alignés ou si certaines pièces ne peuvent pas être montées, vérifiez que les vis sont utilisées correctement et Ajustez leur serrage.

Hardware

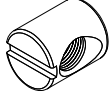
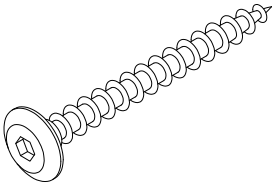
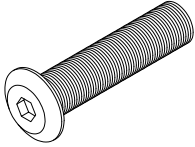
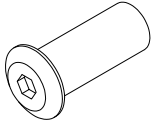
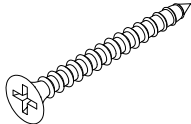
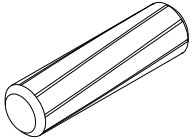
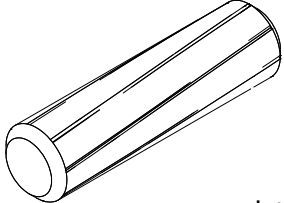
Part List : WF314085

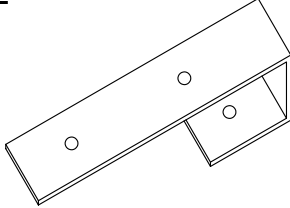
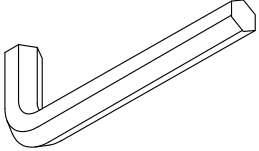
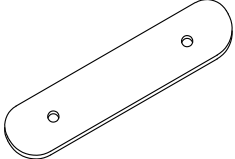
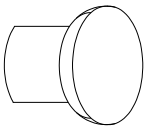
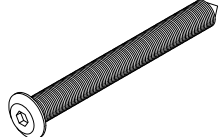
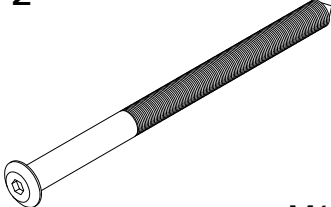
<p>A x 20</p>  <p>M6x80</p>	<p>B x 24</p>  <p>M6x110</p>	<p>C x 48</p>  <p>Φ10x12</p>
<p>D x 18</p>  <p>M6x50</p>	<p>E x 5</p>  <p>M6x30</p>	<p>F x 5</p>  <p>M6x20</p>
<p>G x 64</p>  <p>Φ4x30</p>	<p>H x 60</p>  <p>Φ8x30</p>	<p>I x 4</p>  <p>Φ12x30</p>
<p>J x 12</p>  <p>Φ3.5x15</p>	<p>K x 2</p> 	<p>L x 2</p> 
<p>M x 3</p> 	<p>N x 10</p>  <p>Φ8</p>	<p>O x 2</p>  <p>M6x70</p>
<p>P x 2</p>  <p>M6x100</p>		

ASSEMBLY INSTRUCTIONS

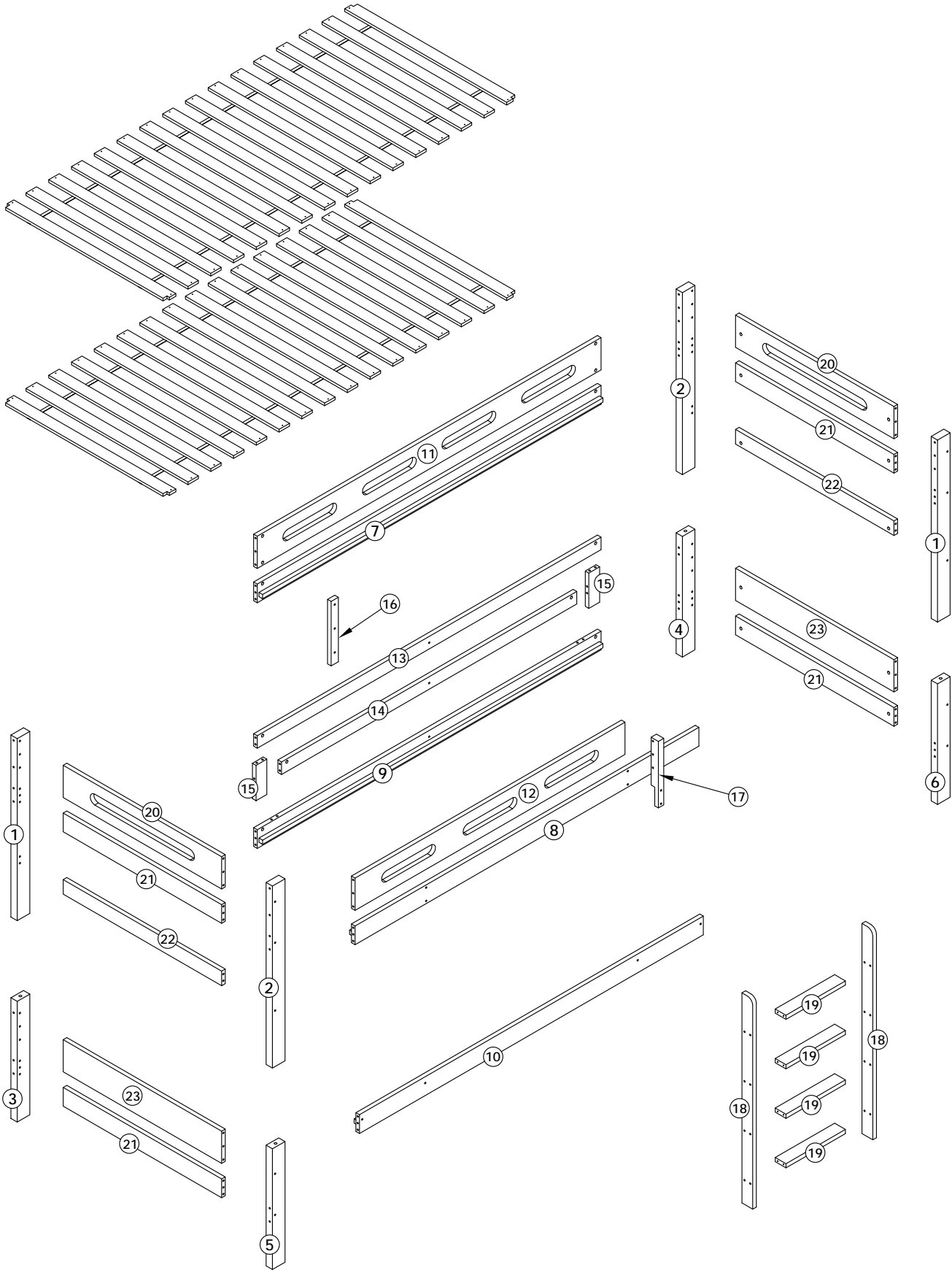

Etagenbett

Part List : WF314085

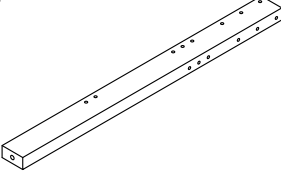
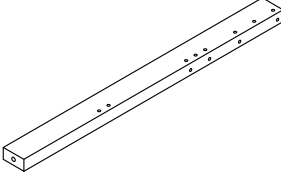
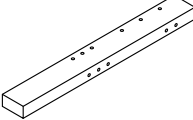
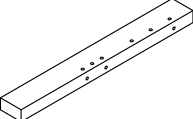
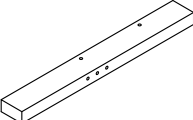
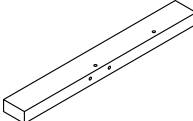
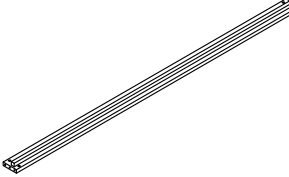
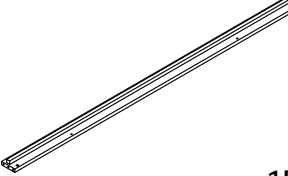
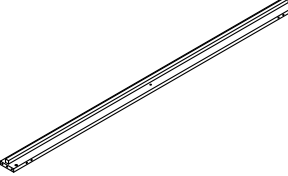
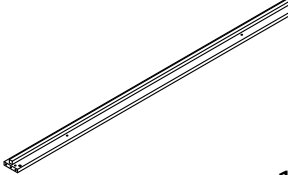
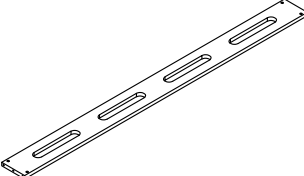
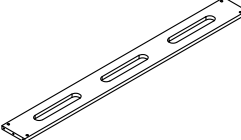
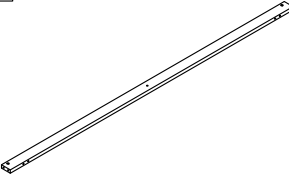
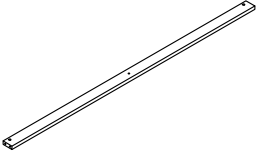
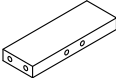
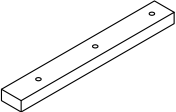
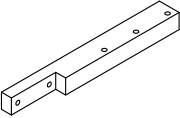
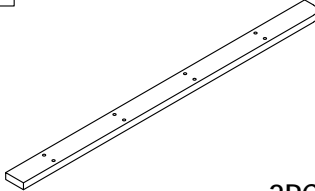
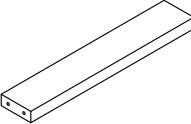

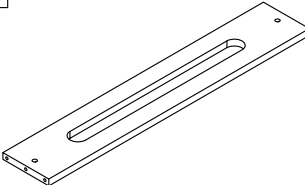
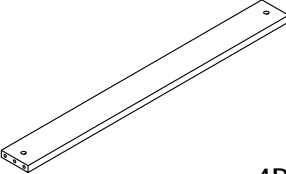
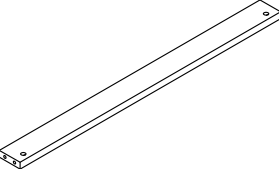
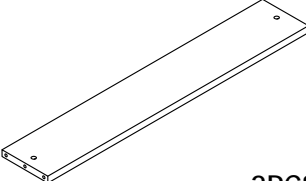
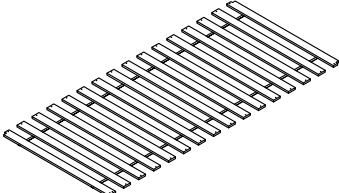

1  2PCS	2  2PCS	3  1PC	4  1PC
5  1PC	6  1PC	7  1PC	8  1PC
9  1PC	10  1PC	11  1PC	12  1PC
13  1PC	14  1PC	15  2PCS	16  1PC
17  1PC	18  2PCS	19  4PCS	

Part List : WF314086

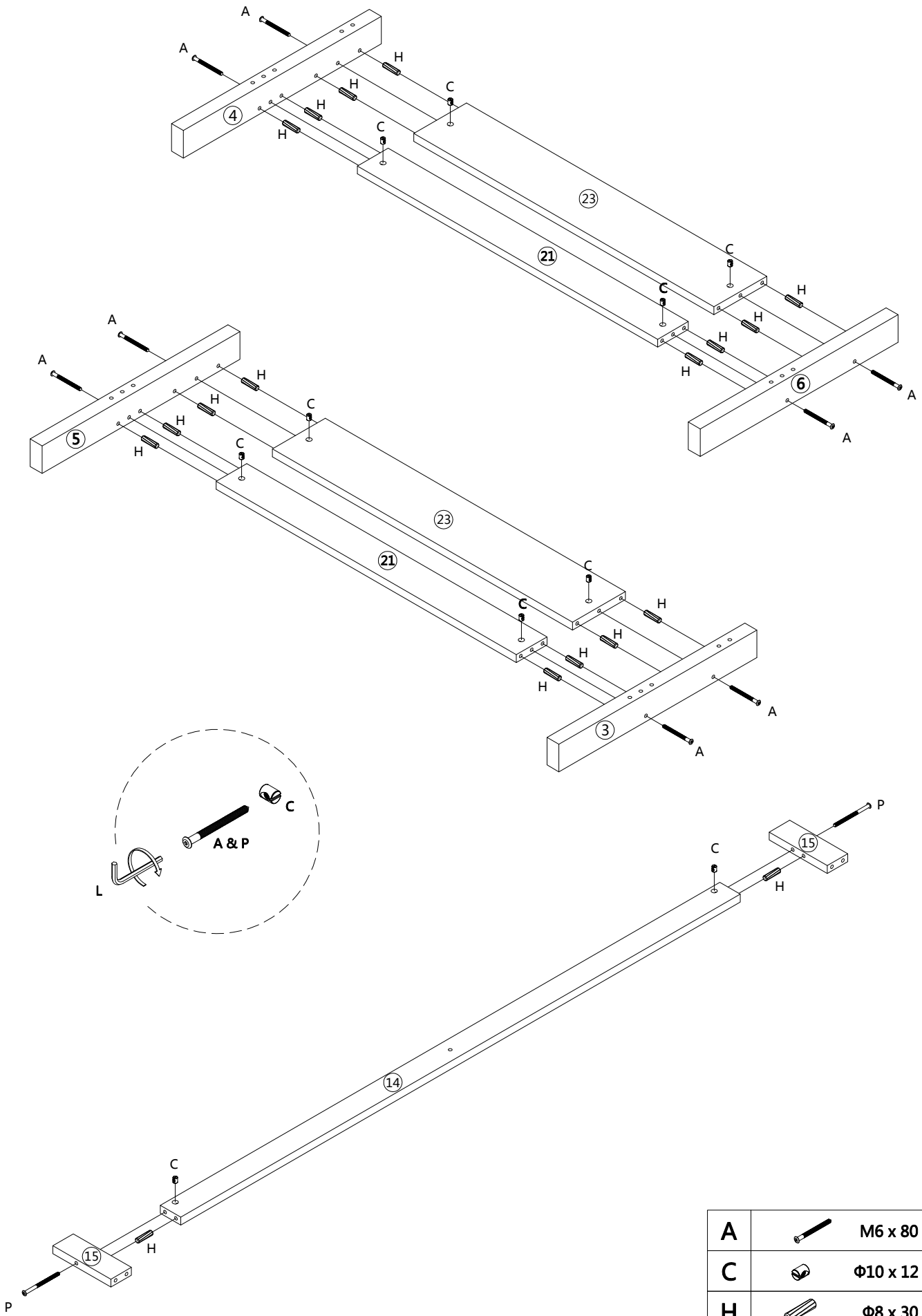
20  2PCS	21  4PCS	22  2PCS	23  2PCS
 16PCS x 2			

STEP:1



A		M6 x 80	8
C		Φ10 x 12	10
H		Φ8 x 30	18
P		M6 x 100	2

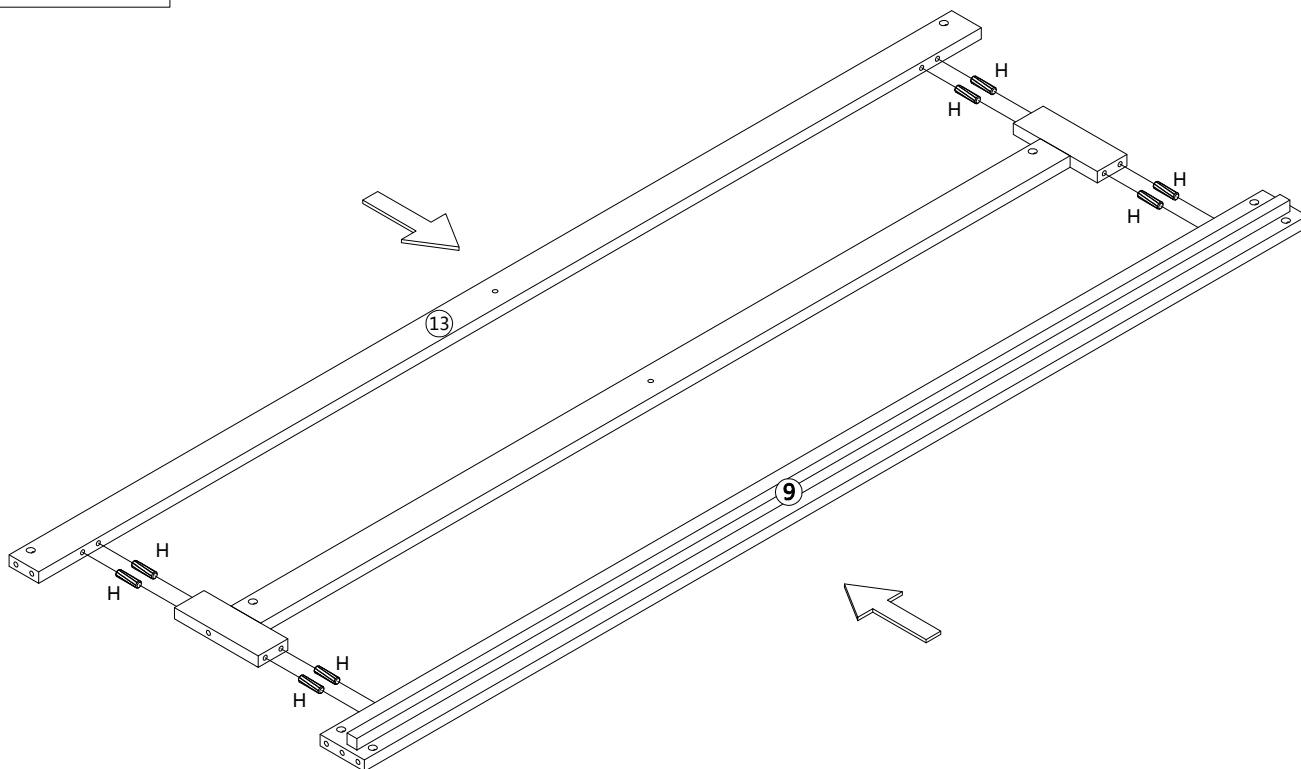

STEP:2



H		Ø8 x 30	8
---	---	---------	---

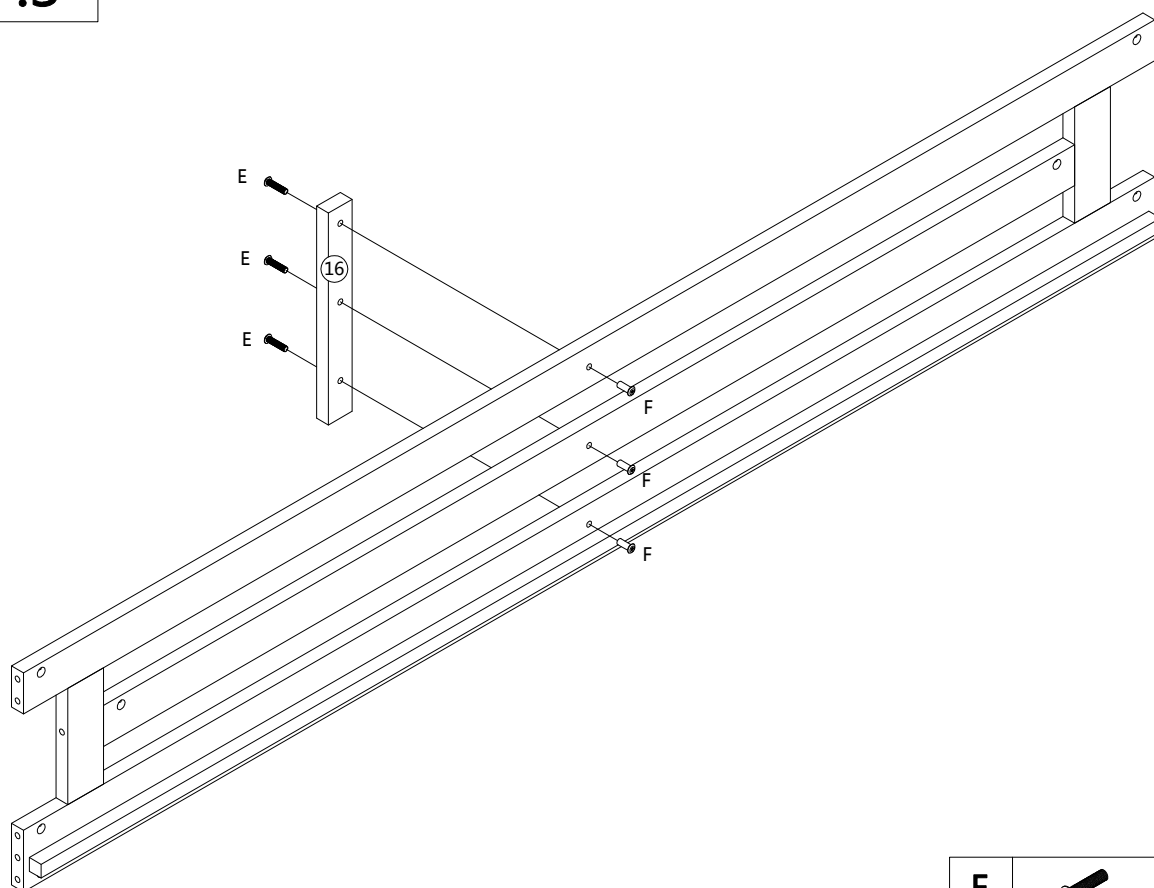

STEP:3

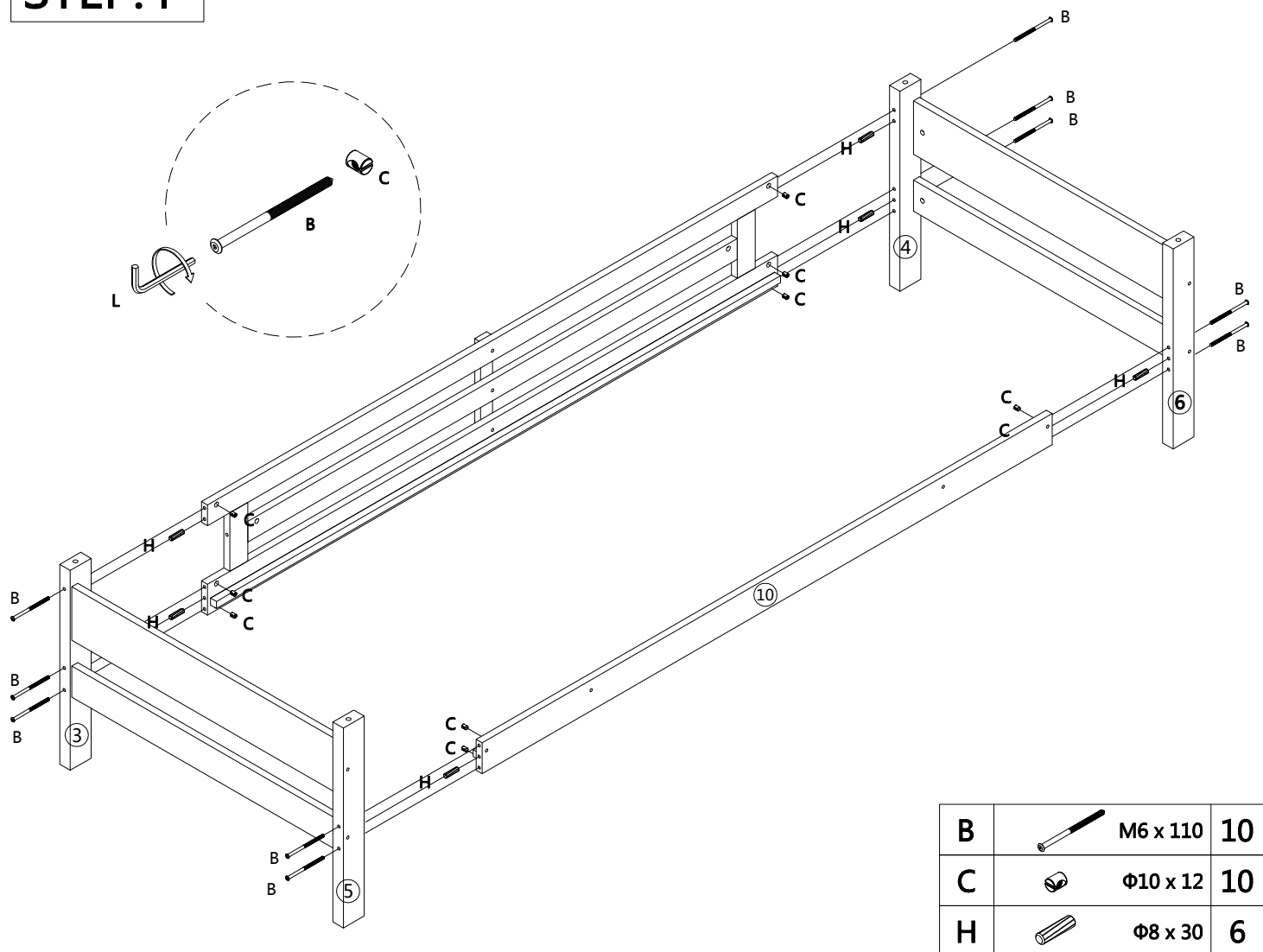

E		M6 x 30	3
F		M6 x 20	3

STEP:4



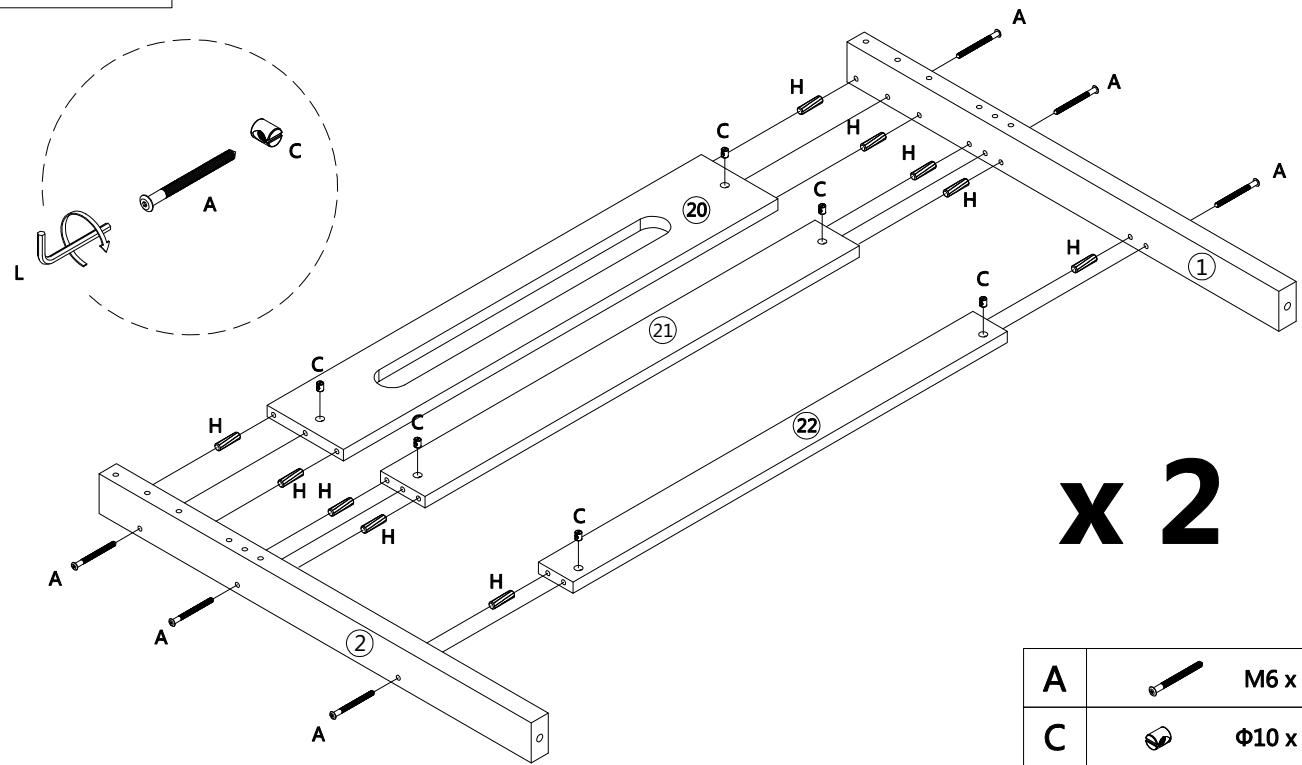

B		M6 x 110	10
C		Φ10 x 12	10
H		Φ8 x 30	6

STEP:5



x 2

A		M6 x 80	12
C		Φ10 x 12	12
H		Φ8 x 30	20

STEP:6

OPTION A / OPTION B

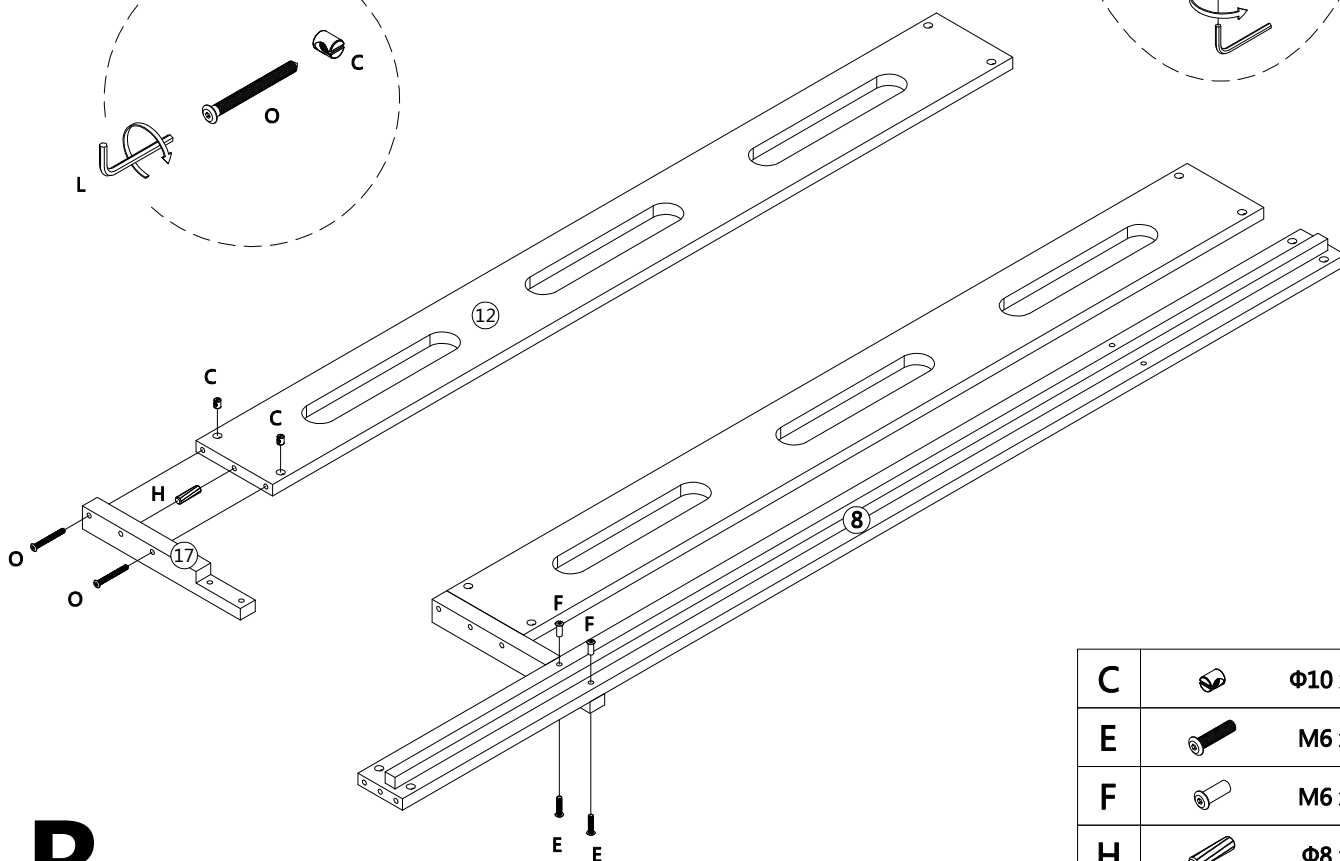
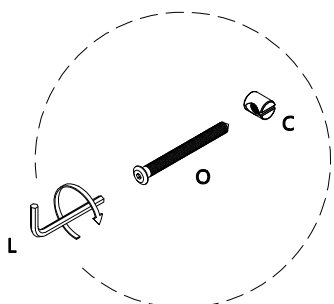
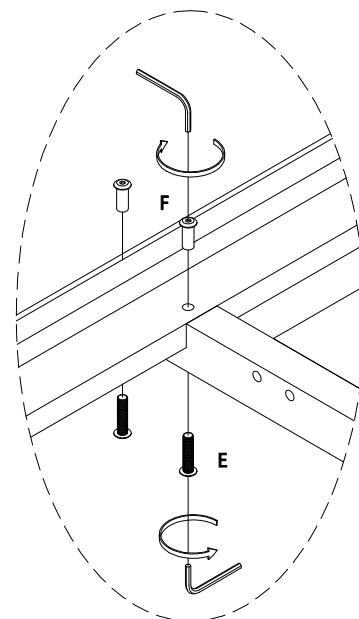
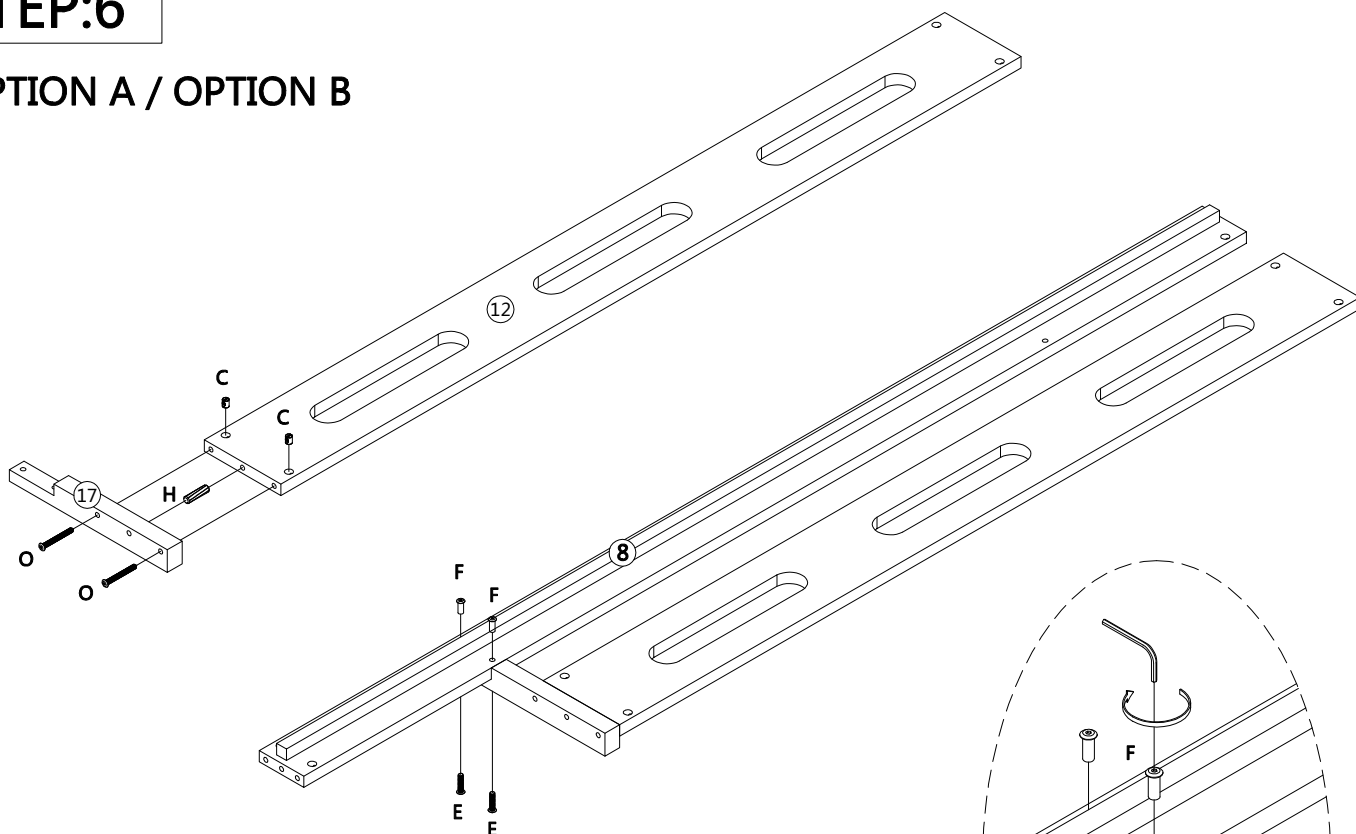

R

C		Φ10 x 12	2
E		M6 x 30	2
F		M6 x 20	2
H		Φ8 x 30	1
O		M6 x 70	2

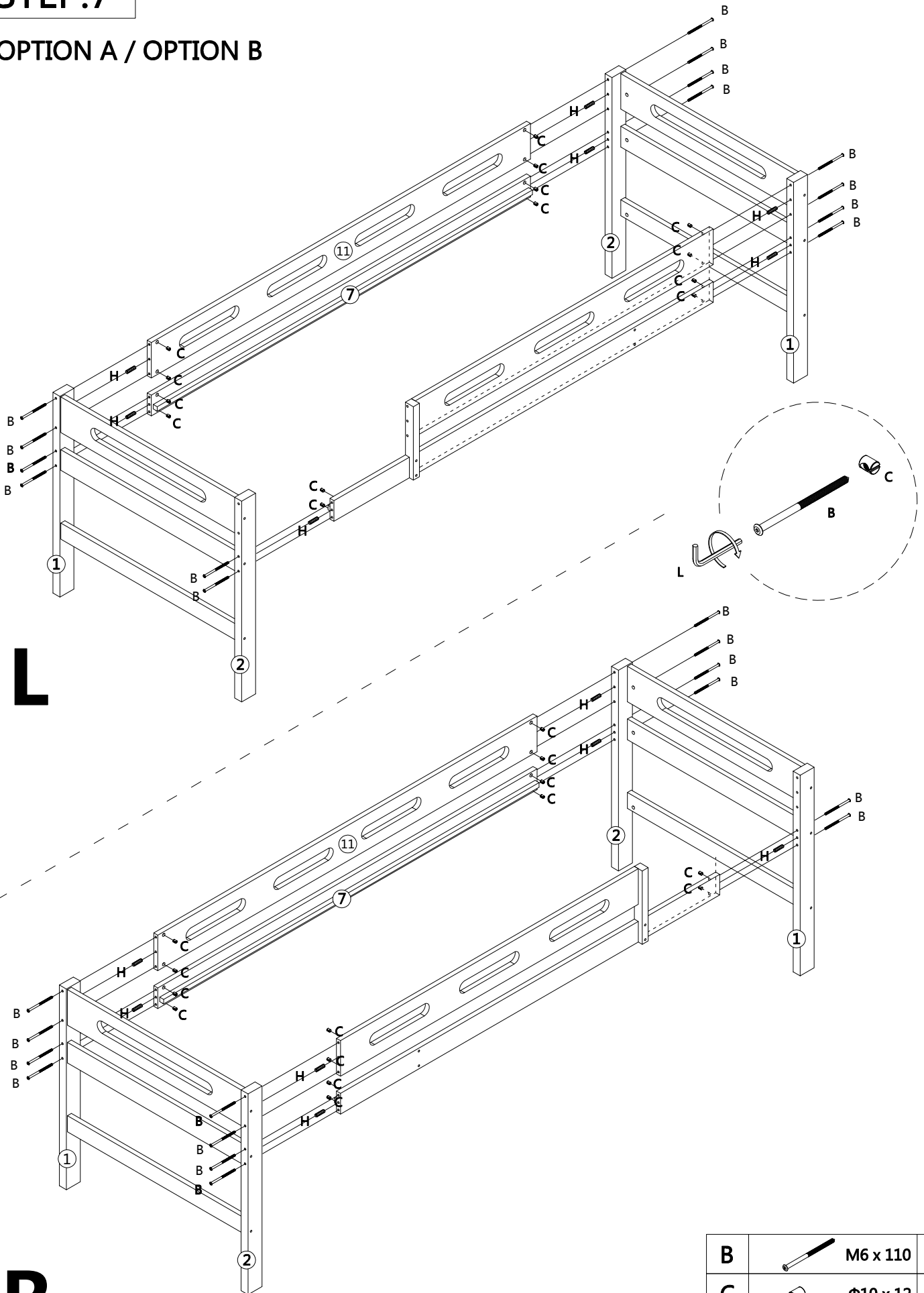

STEP:7

OPTION A / OPTION B



L



R

B		M6 x 110	14
C		Φ10 x 12	14
H		Φ8 x 30	7

STEP:8

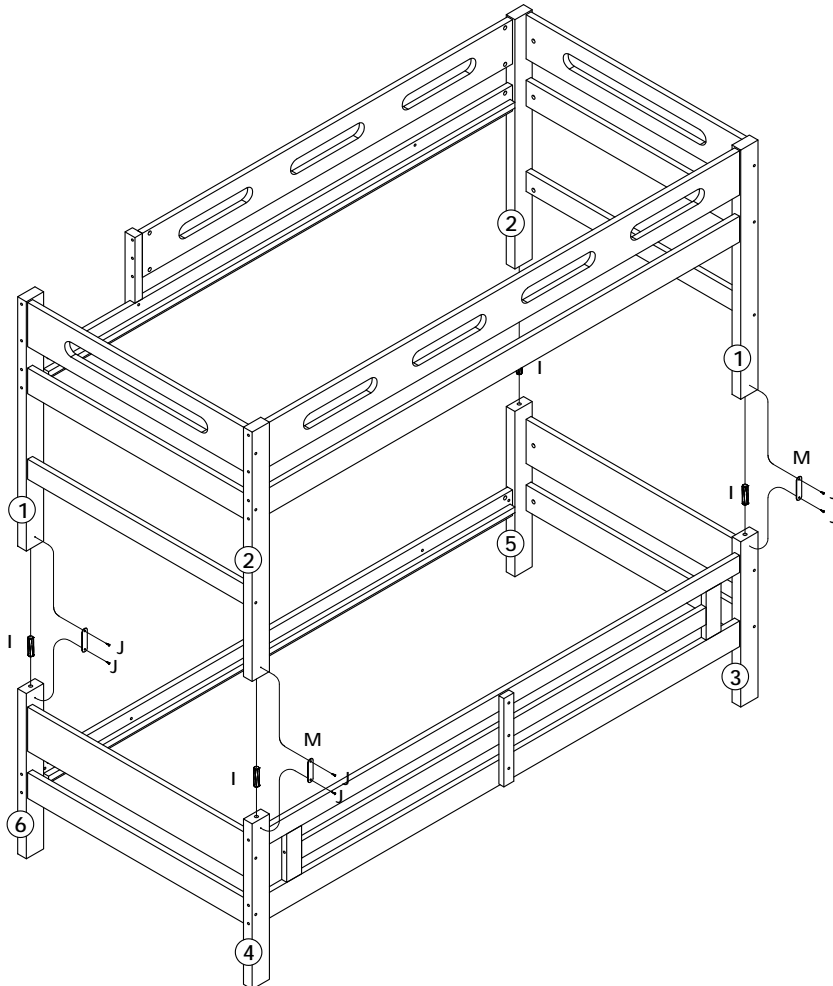
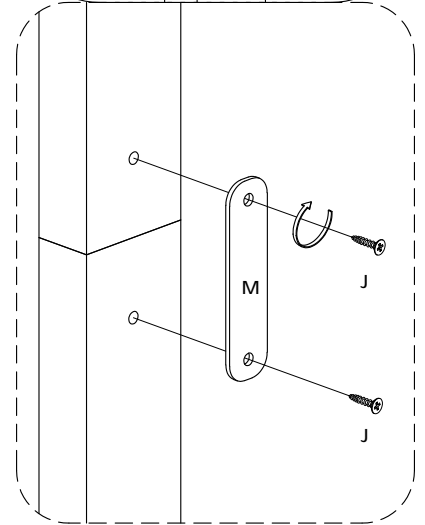
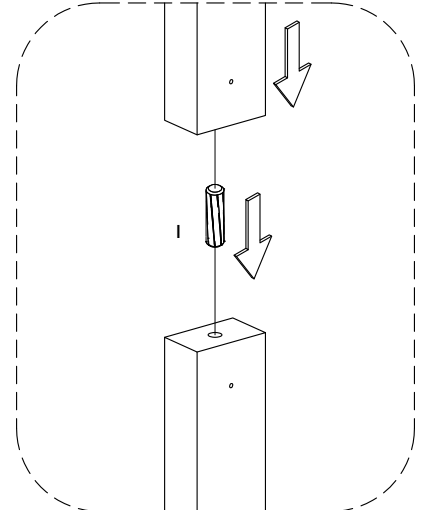
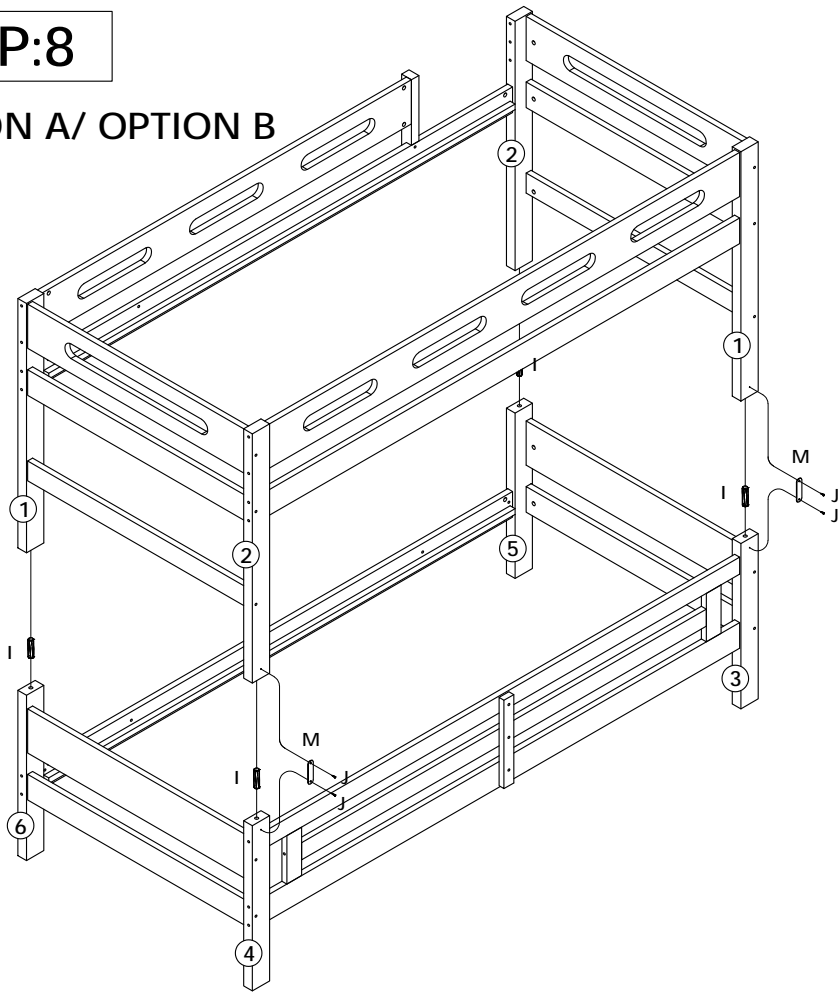

OPTION A/ OPTION B



I		Φ12 x 60	4
J		Φ3.5 x 15	6
M			3

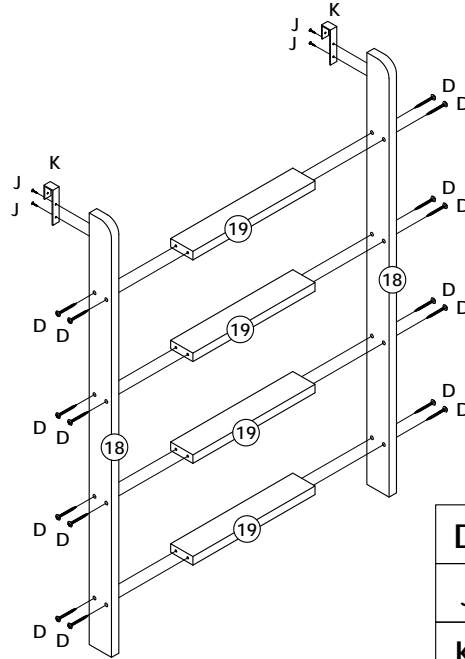
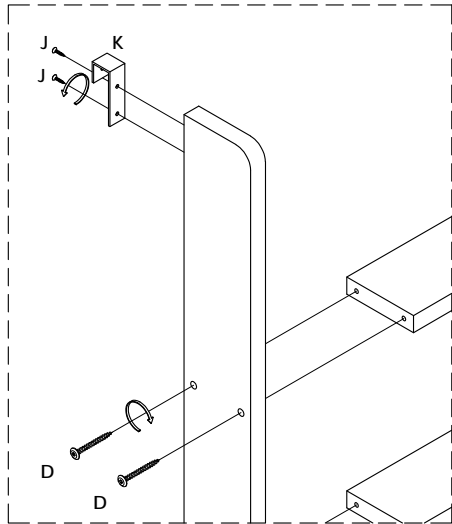

STEP:9

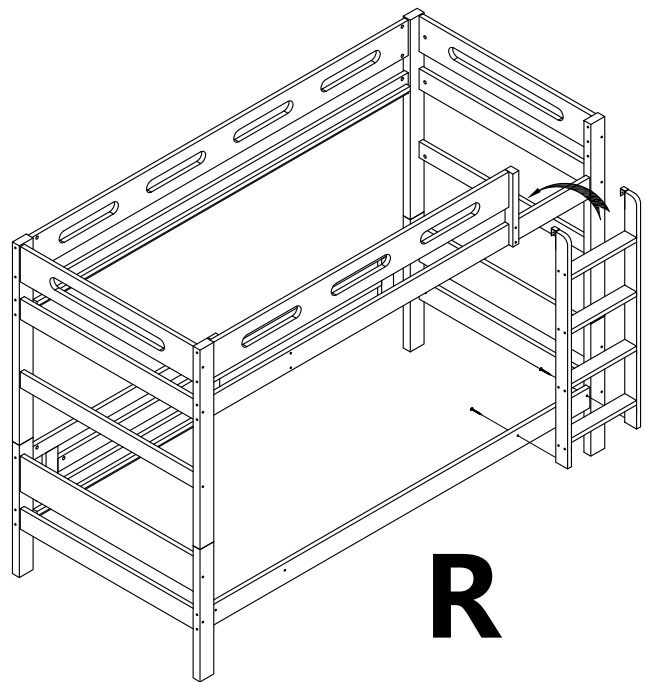
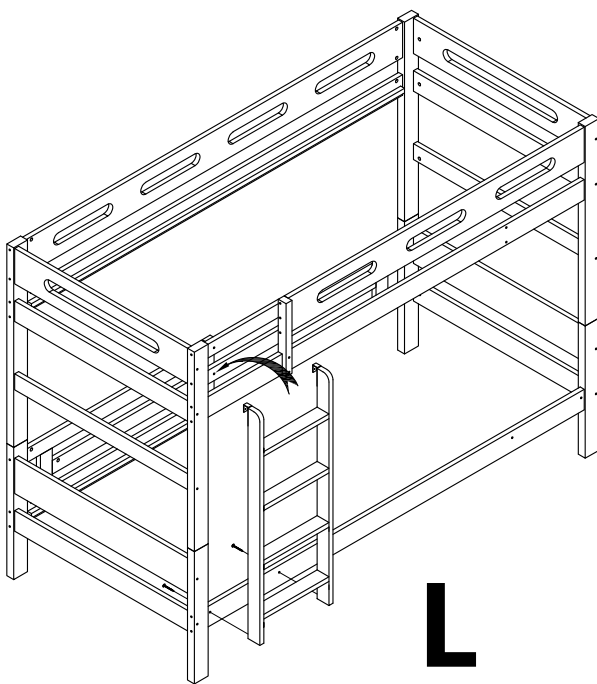
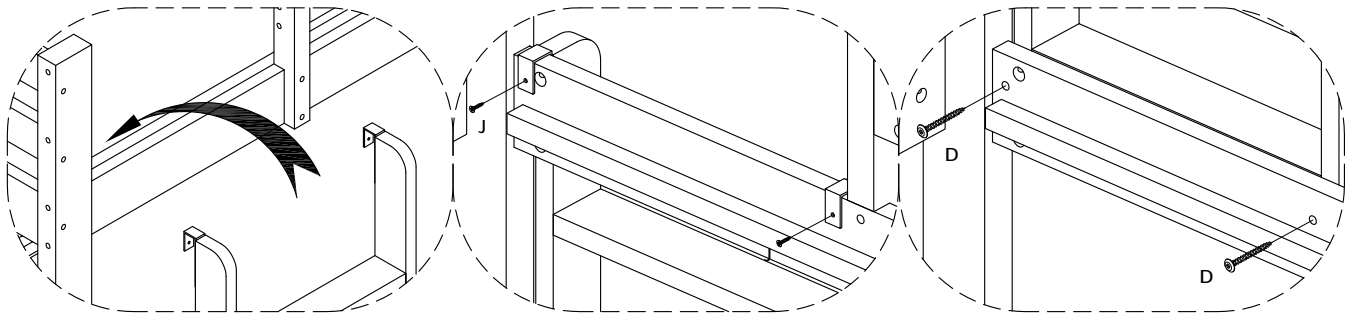

D		M6 x 50	16
J		Φ3.5 x 15	4
K			2

STEP:10 OPTION A / OPTION B



D		M6 x 50	2
J		Φ3.5 x 15	2

STEP:11

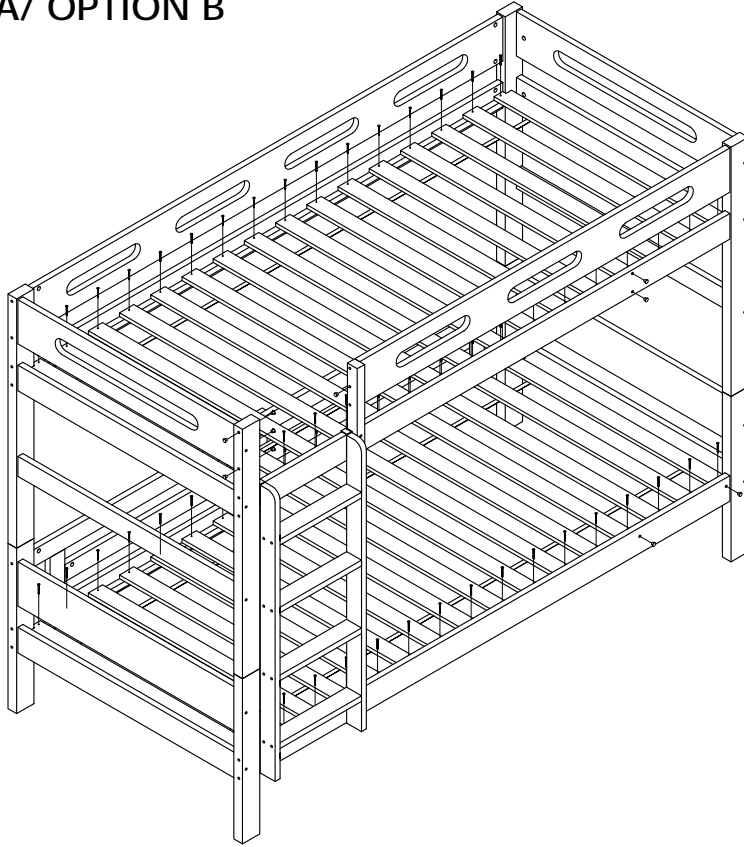

OPTION A/ OPTION B

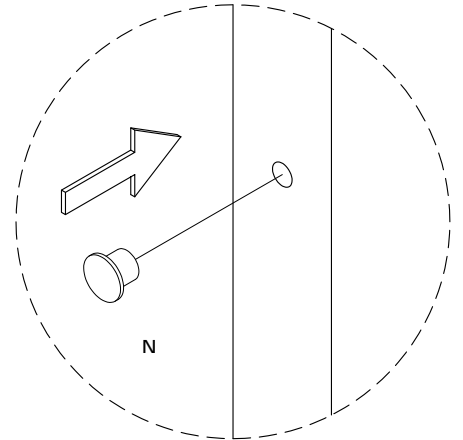
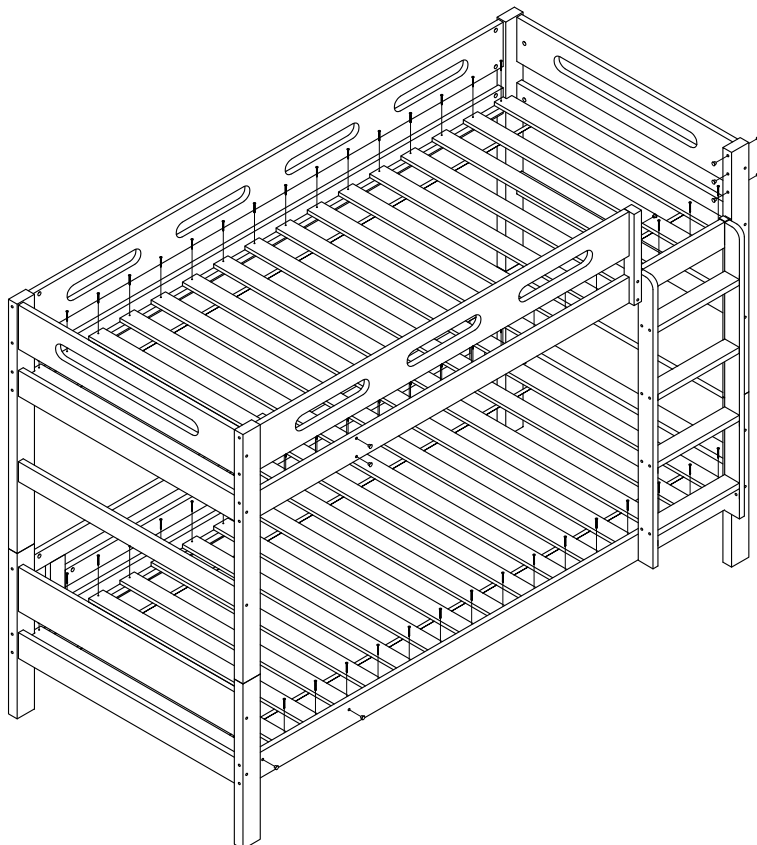
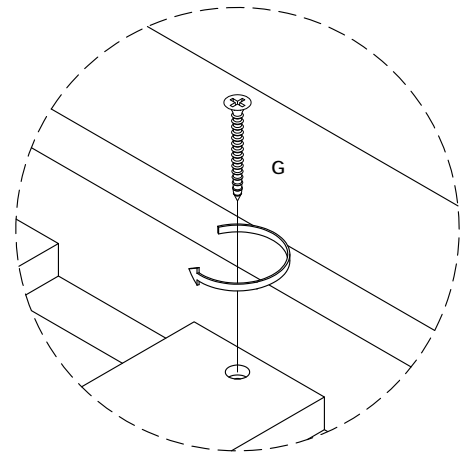

L



R

G		Φ4 x 30	64
N		Φ8	10